



*User Guide*

---

***SI-Universal  
Encoder***

---

Part Number: 0478-0214-03  
Issue: 3

## Original Instructions

For the purposes of compliance with the EU Machinery Directive 2006/42/EC, the English version of this manual is the Original Instructions. Manuals in other languages are Translations of the Original Instructions.

### Documentation

Manuals are available to download from the following locations: <http://www.drive-setup.com/ctdownloads>

The information contained in this manual is believed to be correct at the time of printing and does not form part of any contract. The manufacturer reserves the right to change the specification of the product and its performance, and the contents of the manual, without notice.

### Warranty and Liability

In no event and under no circumstances shall the manufacturer be liable for damages and failures due to misuse, abuse, improper installation, or abnormal conditions of temperature, dust, or corrosion, or failures due to operation outside the published ratings. The manufacturer is not liable for consequential and incidental damages. Contact the supplier of the drive for full details of the warranty terms.

### Environmental policy

Control Techniques Ltd operates an Environmental Management System (EMS) that conforms to the International Standard ISO 14001.

Further information on our Environmental Policy can be found at: <http://www.drive-setup.com/environment>

### Restriction of Hazardous Substances (RoHS)

The products covered by this manual comply with European and International regulations on the Restriction of Hazardous Substances including EU directive 2011/65/EU and the Chinese Administrative Measures for Restriction of Hazardous Substances in Electrical and Electronic Products.

### Disposal and Recycling (WEEE)



When electronic products reach the end of their useful life, they must not be disposed of along with domestic waste but should be recycled by a specialist recycler of electronic equipment. Control Techniques products are designed to be easily dismantled into their major component parts for efficient recycling. The majority of materials used in the product are suitable for recycling.

Product packaging is of good quality and can be re-used. Large products are packed in wooden crates. Smaller products are packaged in strong cardboard cartons which have a high recycled fibre content. Cartons can be re-used and recycled. Polythene, used in protective film and bags for wrapping the product, can be recycled. When preparing to recycle or dispose of any product or packaging, please observe local legislation and best practice.

### REACH legislation

EC Regulation 1907/2006 on the Registration, Evaluation, Authorisation and restriction of Chemicals (REACH) requires the supplier of an article to inform the recipient if it contains more than a specified proportion of any substance which is considered by the European Chemicals Agency (ECHA) to be a Substance of Very High Concern (SVHC) and is therefore listed by them as a candidate for compulsory authorisation.

Further information on our compliance with REACH can be found at: <http://www.drive-setup.com/reach>

### Registered Office

**Nidec Control Techniques Ltd**  
**The Gro**  
**Newtown**  
**Powys**  
**SY16 3BE**  
**UK**

Registered in England and Wales. Company Reg. No. 01236886.

## **Copyright**

The contents of this publication are believed to be correct at the time of printing. In the interests of a commitment to a policy of continuous development and improvement, the manufacturer reserves the right to change the specification of the product or its performance, or the contents of the guide, without notice.

All rights reserved. No parts of this guide may be reproduced or transmitted in any form or by any means, electrical or mechanical including photocopying, recording or by an information storage or retrieval system, without permission in writing from the publisher.

Copyright © January 2018 Nidec Control Techniques Ltd

---

---

# Contents

---

<b>1</b>	<b>How to use this guide .....</b>	<b>6</b>
1.1	Intended personnel .....	6
1.2	Information .....	6
<b>2</b>	<b>Safety information .....</b>	<b>7</b>
2.1	Warnings, Cautions and Notes .....	7
2.2	Important safety information. Hazards. Competence of designers and installers .....	7
2.3	Responsibility .....	7
2.4	Compliance with regulations .....	7
2.5	Electrical hazards .....	8
2.6	Stored electrical charge .....	8
2.7	Mechanical hazards .....	8
2.8	Access to equipment .....	9
2.9	Environmental limits .....	9
2.10	Hazardous environments .....	9
2.11	Motor .....	9
2.12	Mechanical brake control .....	9
2.13	Adjusting parameters .....	9
2.14	Electromagnetic compatibility (EMC) .....	9
<b>3</b>	<b>Introduction .....</b>	<b>10</b>
3.1	Features .....	10
3.2	Option module identification .....	10
3.3	Set-up parameters .....	10
3.4	Compatibility with encoder types .....	11
3.5	Encoder feedback selection .....	19
3.6	Considerations .....	23
<b>4</b>	<b>Mechanical Installation .....</b>	<b>25</b>
4.1	General installation .....	25
<b>5</b>	<b>Electrical installation .....</b>	<b>26</b>
5.1	Basic Functions .....	26
5.2	Wiring, Shield connections .....	30
<b>6</b>	<b>Getting started .....</b>	<b>35</b>
6.1	Installation .....	35
6.2	Setting up a feedback device .....	35
6.3	Encoder Simulation Output Set-up .....	43
6.4	Freeze System .....	47
6.5	Thermistor input .....	47
<b>7</b>	<b>Parameters .....</b>	<b>48</b>
7.1	Introduction .....	48
7.2	Menu 1x parameter for P1 Interface .....	49
7.3	Menu 2x parameters for P2 interface .....	103

<b>8</b>	<b>Advanced operation .....</b>	<b>125</b>
8.1	Encoder communications .....	125
<b>9</b>	<b>Diagnostics .....</b>	<b>128</b>
9.1	Overview .....	128
<b>10</b>	<b>Terminal data .....</b>	<b>131</b>
10.1	15 Way D-type connectors .....	131
10.2	10-Way pluggable connections .....	135

---

# 1 How to use this guide

---

## 1.1 Intended personnel

This guide is intended for personnel who have the necessary training and experience in system design, installation, commissioning and maintenance.

## 1.2 Information

This guide contains information covering the identification of the option module, terminal layout for installation, installation of the option module to the drive, parameter details and diagnosis information. Additional to the aforementioned are the specifications of the option module.

## 2 Safety information

### 2.1 Warnings, Cautions and Notes



A Warning contains information which is essential for avoiding a safety hazard.



A Caution contains information which is necessary for avoiding a risk of damage to the product or other equipment.

#### NOTE

A Note contains information which helps to ensure correct operation of the product.

### 2.2 Important safety information. Hazards. Competence of designers and installers

This guide applies to products which control electric motors either directly (drives) or indirectly (controllers, option modules and other auxiliary equipment and accessories). In all cases the hazards associated with powerful electrical drives are present, and all safety information relating to drives and associated equipment must be observed.

Specific warnings are given at the relevant places in this guide.

Drives and controllers are intended as components for professional incorporation into complete systems. If installed incorrectly they may present a safety hazard. The drive uses high voltages and currents, carries a high level of stored electrical energy, and is used to control equipment which can cause injury. Close attention is required to the electrical installation and the system design to avoid hazards either in normal operation or in the event of equipment malfunction. System design, installation, commissioning/start-up and maintenance must be carried out by personnel who have the necessary training and competence. They must read this safety information and this guide carefully.

### 2.3 Responsibility

It is the responsibility of the installer to ensure that the equipment is installed correctly with regard to all instructions given in this guide. They must give due consideration to the safety of the complete system, so as to avoid the risk of injury both in normal operation and in the event of a fault or of reasonably foreseeable misuse.

The manufacturer accepts no liability for any consequences resulting from inappropriate, negligent or incorrect installation of the equipment.

### 2.4 Compliance with regulations

The installer is responsible for complying with all relevant regulations, such as national wiring regulations, accident prevention regulations and electromagnetic compatibility (EMC) regulations. Particular attention must be given to the cross-sectional areas of conductors, the selection of fuses or other protection, and protective ground (earth) connections.

This guide contains instructions for achieving compliance with specific EMC standards. All machinery to be supplied within the European Union in which this product is used must comply with the following directives:  
2006/42/EC Safety of machinery.  
2014/30/EU: Electromagnetic Compatibility.

## 2.5 Electrical hazards

The voltages used in the drive can cause severe electrical shock and/or burns, and could be lethal. Extreme care is necessary at all times when working with or adjacent to the drive. Hazardous voltage may be present in any of the following locations:

- AC and DC supply cables and connections
- Output cables and connections
- Many internal parts of the drive, and external option units

Unless otherwise indicated, control terminals are single insulated and must not be touched.

The supply must be disconnected by an approved electrical isolation safety device before gaining access to the electrical connections.

The STOP and Safe Torque Off functions of the drive do not isolate dangerous voltages from the output of the drive or from any external option unit.

The drive must be installed in accordance with the instructions given in this guide. Failure to observe the instructions could result in a fire hazard.

## 2.6 Stored electrical charge

The drive contains capacitors that remain charged to a potentially lethal voltage after the AC supply has been disconnected. If the drive has been energized, the AC supply must be isolated at least ten minutes before work may continue.

## 2.7 Mechanical hazards

Careful consideration must be given to the functions of the drive or controller which might result in a hazard, either through their intended behaviour or through incorrect operation due to a fault. In any application where a malfunction of the drive or its control system could lead to or allow damage, loss or injury, a risk analysis must be carried out, and where necessary, further measures taken to reduce the risk - for example, an over-speed protection device in case of failure of the speed control, or a fail-safe mechanical brake in case of loss of motor braking.

**With the sole exception of the Safe Torque Off function, none of the drive functions must be used to ensure safety of personnel, i.e. they must not be used for safety-related functions.**

The Safe Torque Off function may be used in a safety-related application. The system designer is responsible for ensuring that the complete system is safe and designed correctly according to the relevant safety standards.

The design of safety-related control systems must only be done by personnel with the required training and experience. The Safe Torque Off function will only ensure the safety of a machine if it is correctly incorporated into a complete safety system. The system must be subject to a risk assessment to confirm that the residual risk of an unsafe event is at an acceptable level for the application.



## 2.8 Access to equipment

Access must be restricted to authorized personnel only. Safety regulations which apply at the place of use must be complied with.

## 2.9 Environmental limits

Instructions in this guide regarding transport, storage, installation and use of the equipment must be complied with, including the specified environmental limits. This includes temperature, humidity, contamination, shock and vibration. Drives must not be subjected to excessive physical force.

## 2.10 Hazardous environments

The equipment must not be installed in a hazardous environment (i.e. a potentially explosive environment).

## 2.11 Motor

The safety of the motor under variable speed conditions must be ensured.

To avoid the risk of physical injury, do not exceed the maximum specified speed of the motor.

Low speeds may cause the motor to overheat because the cooling fan becomes less effective, causing a fire hazard. The motor should be installed with a protection thermistor. If necessary, an electric forced vent fan should be used.

The values of the motor parameters set in the drive affect the protection of the motor. The default values in the drive must not be relied upon. It is essential that the correct value is entered in the Motor Rated Current parameter.

## 2.12 Mechanical brake control

Any brake control functions are provided to allow well co-ordinated operation of an external brake with the drive. While both hardware and software are designed to high standards of quality and robustness, they are not intended for use as safety functions, i.e. where a fault or failure would result in a risk of injury. In any application where the incorrect operation of the brake release mechanism could result in injury, independent protection devices of proven integrity must also be incorporated.

## 2.13 Adjusting parameters

Some parameters have a profound effect on the operation of the drive. They must not be altered without careful consideration of the impact on the controlled system.

Measures must be taken to prevent unwanted changes due to error or tampering.

## 2.14 Electromagnetic compatibility (EMC)

Installation instructions for a range of EMC environments are provided in the relevant Power Installation Guide. If the installation is poorly designed or other equipment does not comply with suitable standards for EMC, the product might cause or suffer from disturbance due to electromagnetic interaction with other equipment. It is the responsibility of the installer to ensure that the equipment or system into which the product is incorporated complies with the relevant EMC legislation in the place of use.

# 3 Introduction

## 3.1 Features

The SI-Universal Encoder module allows for various types of feedback device to be connected to the drive and to be configured for either reference or main motor control feedback. The module also has a simulated encoder output which can be programmed to operate in either AB, FD, FR or SSI mode (software simulation), or alternatively use a hardware simulated encoder output from either the modules encoder input or the drives main encoder input (provided the encoder type is suitable).

## 3.2 Option module identification

The SI-Universal Encoder can be identified by:

1. The label located on the topside of the option module.
2. The color coding across the front of the option module: Dark brown.

Figure 3-1 SI-Universal Encoder label

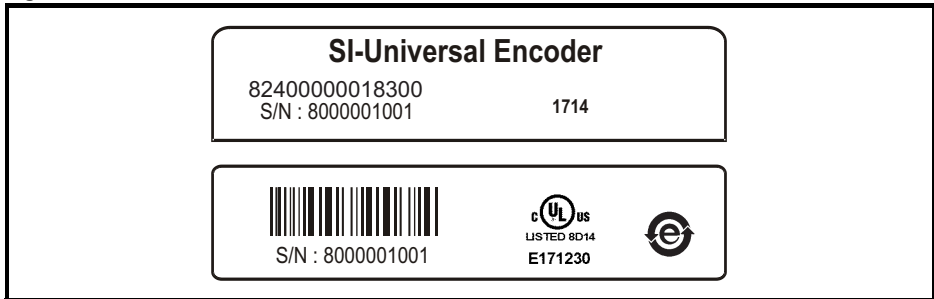

### 3.2.1 Date code format

The date code is four numbers. The first two numbers indicate the year and the remaining numbers indicate the week of the year in which the drive was built.

**Example:**

A date code of 1710 would correspond to week 10 of year 2017.

## 3.3 Set-up parameters

The SI-Universal Encoder option module provides two position feedback interfaces, two freeze systems, encoder simulation output and a temperature sensor input. The setup menus for these functions depend on which slot the option module is fitted in as shown in Table 3-1.

Table 3-1 Set-up parameters

Functions	Slot 1	Slot 2	Slot 3
P1 position interface, freeze system, encoder simulation output and temperature sensor input	Menu 15	Menu 16	Menu 17
P2 position interface	Menu 25	Menu 26	Menu 27

The method used to determine the menu or parameter is as follows:

- Pr **1x.ppp** - Where **1x** signifies the menu allocated to the option module P1 setup menu (Menu 15, Menu16 or Menu 17) and **ppp** signifies the parameter number within the set-up menu for the P1 position interface.

- Pr **2x.ppp** - Where **2x** signifies the menu allocated to the option module P2 setup menu (Menu 25, Menu 26 or Menu 27) and **ppp** signifies the parameter number within the set-up menu for the P2 position interface.

### 3.4 Compatibility with encoder types

The SI-Universal Encoder module is compatible with the following encoder types.

#### 3.4.1 Incremental encoders AB, FD, FR and SC

These types of encoders give incremental position and are intended to be used for control in RFC-A mode. They can be used for operation in RFC-S mode but a phasing test is required at every power-up.

Type	Encoder	Description	Pr1x.038	Pr2x.038
Incremental	AB	Quadrature incremental encoder. With or without marker pulse.	0	1
	FD	Incremental encoder with frequency and direction outputs. With or without marker pulse pulse.	1	2
	FR	Incremental encoder with forward and reverse outputs. With or without marker pulse.	2	3
	SC	SinCos encoder with no serial communications No optional marker pulse.	6	

Quadrature detection logic determines rotation from the phase relationship of the two channels.

These encoders can be used for RFC-A and RFC-S mode of operation and are available with a marker pulse, which identifies each individual rotation of the encoder, and is also used to reset the drive position parameter. The marker pulse is not required for correct operation.

#### NOTE

With this type of feedback, the drive must carry out a phasing test to find the phase offset angle on power up for operation in RFC-S mode.

#### SC

When a SinCos encoder is used additional position resolution is obtained by measuring the magnitude of the signals.

#### NOTE

Refer to section 3.4.2 for information regarding SinCos encoder feedback signals.

Limitations				
Type	Encoder	Max Input Frequency	Max no. of Lines	
Incremental	AB	500 kHz*	100,000	
	FD			
	FR			
	SC	See Table 3-2 <i>Interpolated information based on frequency and voltage level</i> on page 13.		

\* Max input frequency = LPR x max rpm / 60

#### NOTE

The maximum speed in rpm which an encoder connected to The SI-Universal Encoder module can

reach can be calculated from:

Max rpm = (60 x Max input frequency) / Encoder LPR

e.g. For a 4096 line encoder the maximum rpm would be:

$(60 \times 500 \times 10^3) / 4096 = 7324 \text{ rpm}$

**NOTE**

The absolute maximum input frequency for any SC, SinCos encoder used with the SI-Universal Encoder option module is 500 kHz.

### 3.4.2 SinCos encoder feedback signals

For the SinCos encoder to be compatible with the SI-Universal Encoder option module, the output signals from the encoder must be a 1 V peak to peak differential voltage (across sinref to sin and cosref to cos).

**Figure 3-2 Stegmann SinCos encoder feedback signals**

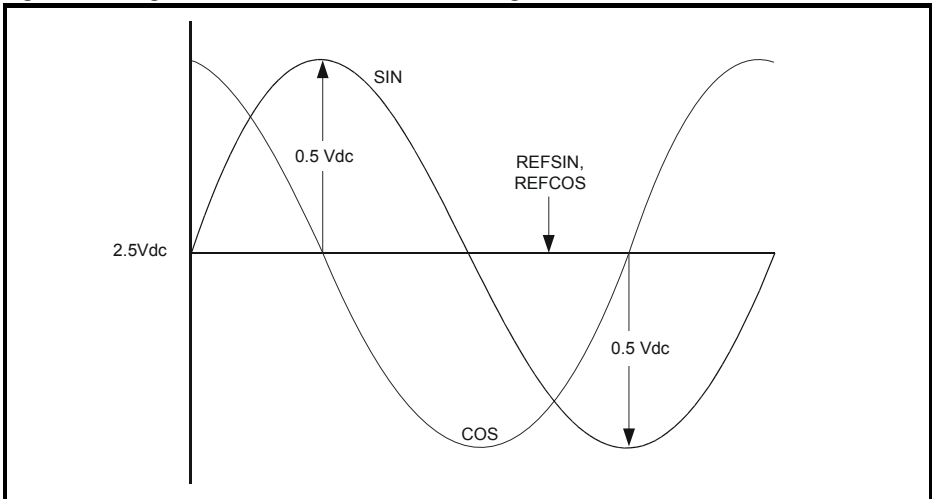

#### Stegmann

Stegmann encoders typically have a 2.5 Vdc offset. The sinref and cosref are a flat DC level at 2.5 Vdc and the cos and sin signals have a 1 V peak to peak waveform biased at 2.5 Vdc.

The result is a 1 V peak to peak differential voltage as show in Figure 3-2.

#### Heidenhain

The Heidenhain Sin and Cos signals with respect to zero volts are offset at 2.5 Vdc as shown in Figure 3-3.

The feedback signals which are seen by The SI-Universal Encoder module are the differential signals Sin - Sin\ and Cos - Cos\ as in Figure 3-3, these being 90° phase shifted and at 1 Vdc peak to peak.

**Figure 3-3 Heidenhain SinCos encoder feedback signals**

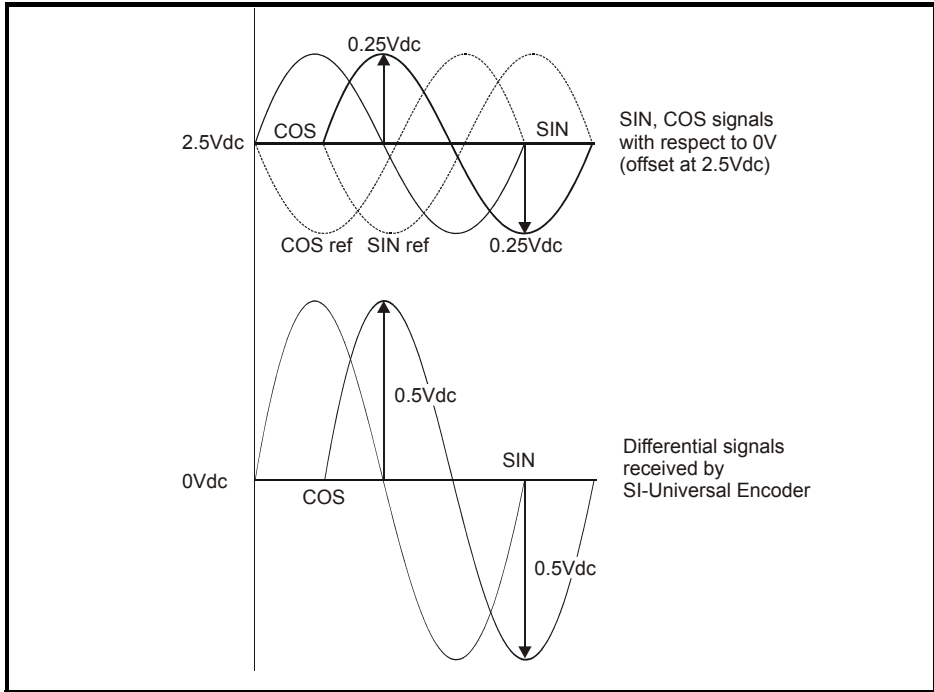

**NOTE**

Encoders are available which have a 1 V peak to peak voltage on sinref, sin, cos and cosref. This results in a 2 V peak to peak voltage seen at the module's terminals. The drive will still function with this type of encoder, however with reduced position resolution equivalent to four times the line rate. (line rate = no. of lines per revolution x revolutions per second.) It is recommended that encoders of this type are not used with a drive, and that the encoder feedback signals should meet the above parameters (1 V peak to peak).

**Sincos encoder resolution**

The sine wave frequency can be up to 500 kHz but the resolution is reduced at high frequency. Table 3-2 shows the number of bits of interpolated information at different frequencies and with different voltage levels at the encoder port. The total resolution in bits per revolution is the ELPR plus the number of bits of interpolated information. Although it is possible to obtain 11 bits of interpolation information, the nominal design value is 10 bits.

**Table 3-2 Interpolated information based on frequency and voltage level**

Volt/Freq	1 kHz	5 kHz	50 kHz	100 kHz	200 kHz	500 kHz
1.2	11	11	10	10	9	8
1.0	11	11	10	9	9	7
0.8	10	10	10	9	8	7
0.6	10	10	9	9	8	7
0.4	9	9	9	8	7	6

How to use this guide
Safety information
<b>Introduction</b>
Mechanical installation
Electrical installation
Getting started
Parameters
Advanced operation
Diagnostics
Terminal data
Index

### 3.4.3 Incremental plus commutation (absolute encoders) AB Servo, FD Servo, FR Servo and SC Servo

Type	Encoder	Description	Pr 1x.038
Incremental plus commutation (absolute encoders)	AB Servo	Quadrature incremental encoder with commutation outputs. With or without marker pulse.	3
	FD Servo	Incremental encoder with frequency, direction and commutation outputs. With or without marker pulse.	4
	FR Servo	Incremental encoder with forward, reverse and commutation outputs. With or without marker pulse.	5
	SC Servo	Absolute SinCos encoder plus commutation signals with or without marker pulse.	12

The incremental part of an incremental encoder with commutation works in exactly the same way as an incremental encoder. The additional channels (U, V and W) give the absolute electrical position to electrical 60°.

When operating the drive in RFC-S mode, the absolute position (to 60° electrical or better) of the machine shaft is required to enable the drive to apply torque in the correct direction. The marker signal is not effective until the shaft passes a particular position, so this cannot be used to determine the absolute position. Therefore in RFC-S mode an encoder with additional commutation is required.

#### NOTE

***The U, V and W commutation signals should have a period that is one electrical revolution as shown in Figure 3-4.***

Therefore with a 6 pole machine the U, V and W commutation signals will repeat three times per mechanical revolution, or with an 8 pole machine four times per mechanical revolution etc.

The U, V and W commutation signals are used when the drive is enabled to locate the position of the machine shaft within 60° electrical so that the current vector can be applied within 30° electrical either side of the correct position for maximum torque production. The torque capability of the drive during this period can be reduced to as low as 0.866 of the nominal level.

Once the shaft has moved through a maximum of 60° electrical, one of the U, V or W signals will have changed state. The location of the waveform edge is used to locate the machine position exactly. This information is then stored by the option module and used until power-down to place the current vector in the correct position for maximum torque. To ensure that this process is carried out correctly the control algorithm waits for two changes of the state of the U, V and W waveforms, after this point maximum torque is available.

Using this type of encoder does not result in any movement when the drive is first enabled after power-up, only a small reduction in torque described above for the first 60° to 120° electrical of movement.

#### NOTE

In AB Servo, FD Servo or FR Servo modes only, the value in Pr **1x.070** provides information on the commutation signal inputs (UVW). Pr **1x.070** permits the user to determine the current segment and status of the commutation signal inputs. For further details refer to Pr **1x.068**.

**Figure 3-4 Example of encoder feedback signals (6 pole commutation signals)**

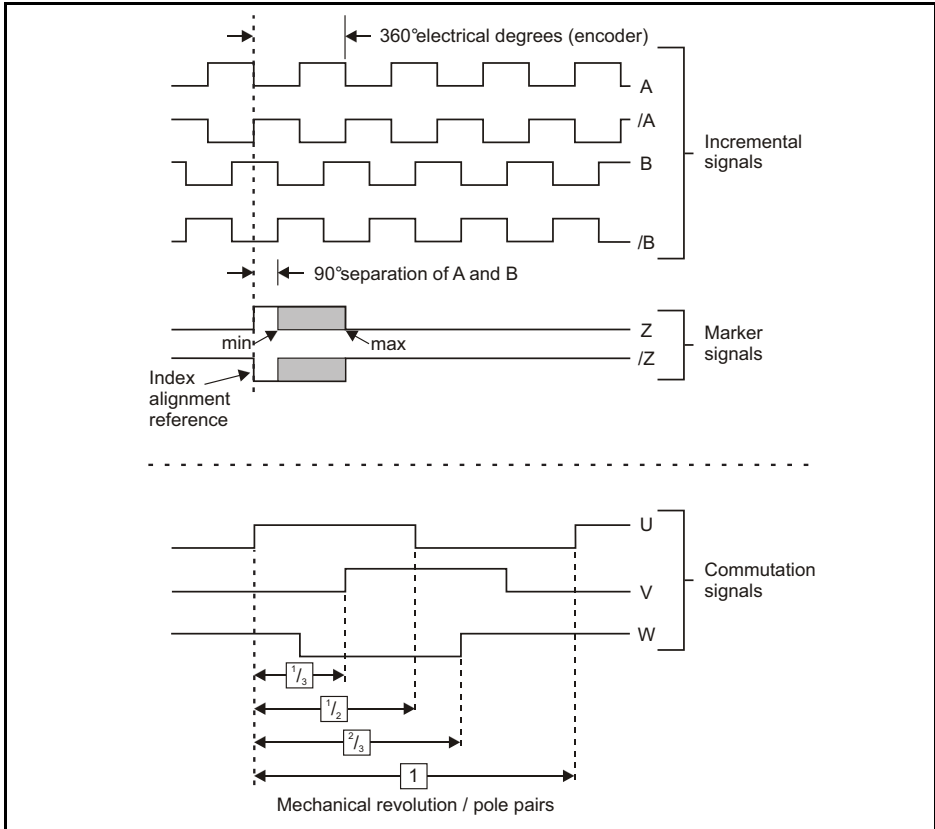

Limitations			
Type	Encoder	Max Input Frequency	Max no. of Lines (LPR)
Incremental plus commutation	AB Servo	500 kHz*	100,000
	FD Servo		
	FR Servo		
	SC Servo	See Table 3-2 <i>Interpolated information based on frequency and voltage level</i> on page 13	

\* Max input frequency = LPR x max rpm / 60

**NOTE**

The maximum speed in rpm which an encoder connected to the SI-Universal Encoder option module can reach, can be calculated from:

$$\text{Max rpm} = (60 \times \text{Max input frequency}) / \text{Encoder LPR}$$

e.g. For a 4096 line encoder the maximum rpm would be:

$$(60 \times 500 \times 10^3) / 4096 = 7324 \text{ rpm}$$

How to use this guide

Safety Information

Introduction

Mechanical Installation

Electrical Installation

Getting started

Parameters

Advanced operation

Diagnostics

Terminal data

Index

### 3.4.4 Incremental plus comms (absolute encoders) SC Hiperface, SC EnDat and SC SSI

Type	Encoder	Description	Pr 1x.038
Incremental plus comms (absolute encoders)	SC Hiperface	Absolute SinCos encoder using Stegmann RS485 comms protocol (HiperFace).	7
	SC EnDat	Absolute SinCos encoder using EnDat comms protocol.	9
	SC SSI	Absolute SinCos encoder using SSI comms protocol.	11
	SC BiSS	Absolute SinCos encoder using BiSS comms protocol	17

The SC Hiperface and SC EnDat encoders can be considered as a mixture of an incremental encoder (analog SinCos feedback signals) and an absolute encoder (serial link used for absolute position). The only difference between the encoders being the serial link protocol.

The RS 485 serial link allows the drive at power up to interrogate the SinCos encoder in comms channel order to determine the initial absolute position of the encoder shaft. When the interrogation is complete and the initial absolute position is known the position is incremented from the absolute value using the analog sine/cosine interface.

The comms channels can then be used for either error checking, Pr 1x.040 or data transfer, Pr 1x.068 to Pr 1x.069. The incremental SinCos plus communications encoder can be used when operating in either RFC-A or RFC-S modes.

**NOTE**

A flux alignment test is required during set up to determine the phase offset angle for operation in servo mode. The results of the alignment test are stored in EEPROM and do not need to be done after every power up.

**NOTE**

The position retrieved during the initialization is compared to the partial position calculated from the measurements of the Sine and Cosine signals. If they do not agree within a certain tolerance a trip is generated.

Limitations				
Type	Encoder	Max Input Frequency *	Max no. of Lines (LPR)	Max Baud Rate (bits/s)
Incremental plus communications	SC Hiperface	Table 3-2 <i>Interpolated information based on frequency and voltage level</i> on page 13	100,000	9600 (fixed)
	SC EnDat			4M
	SC SSI			
	SC BiSS			

\* Max input frequency = LPR x max rpm / 60

**NOTE**

The maximum speed in rpm which an encoder connected to the SI-Universal Encoder can achieve can be calculated from:

$$\text{Max rpm} = (60 \times \text{Max input frequency}) / \text{Encoder LPR}$$

e.g. For a 4096 line encoder the maximum rpm would be:

$$(60 \times 500 \times 10^3) / 4096 = 7324 \text{ rpm}$$

**NOTE**

The absolute maximum input frequency for any SC, SinCos encoder used with the SI-Universal Encoder Module is 500 kHz.



### 3.4.5 Comms only, (absolute encoders) SSI and EnDat

Type	Encoder	Description	Pr 1x.038	Pr 2x.038
Comms (absolute)	EnDat	Absolute EnDat only encoder Additional communications with the encoder is not possible.	8	4
	SSI	Absolute SSI only encoder. Additional communications with the encoder is not possible.	10	5
	BiSS*	Absolute BiSS C mode only encoder Additional communications with the encoder is not possible	13	6

The SSI (Synchronous Serial Interface), EnDat (Encoder Data) and BiSS (Bi-directional Synchronous Serial) encoders have a serial link between the encoder and drive which passes all positional information.

#### NOTE

It should be noted that EnDat, BiSS and SSI encoders must be initialized before their position data can be used. The encoder is automatically initialized at power-up after trips 100 - 135 are reset, or when the initialization parameter (Pr 1x.075) is set to 1.

#### SSI, EnDat, BiSS\*

The interfaces transmit data synchronised with a CLOCK signal provided from the drive. This makes it possible to transmit position values quickly and reliably with only four signal lines.

The main difference between the SSI and the EnDat/BiSS being that the standard SSI encoder is Uni-directional whereas the EnDat and BiSS are Bi-directional. The data transfer for both the SSI, BiSS and the EnDat use the 485 standard for data and clock signals.

Limitations			
Type	Encoder	Max Baud Rate (bits/sec)	Max Speed rpm
Comms Only	EnDat	4 Mbits/sec	50,000 rpm
	SSI		
	BiSS*		

#### NOTE

The SSI input at default is configured to operate in Gray code, this can be changed to binary format by setting Pr 1x.048= 1.

#### NOTE

A flux alignment test is required during set up to determine the phase offset angle for operation in RFC-S mode.

\* BiSS is not currently supported.

### 3.4.6 Linear Encoders

Type	Encoder	Description	Pr 1x.038	Pr 2x.038
Linear encoder	AB	Linear quadrature encoder	0	1
	SC	Linear SinCos encoder	6	
	AB Servo	Digital hall effect + Linear quadrature incremental encoder	3	
	SC Servo	Digital hall effect + Linear SinCos incremental encoder	12	
	SC Hiperface	Linear absolute SinCos encoder	7	
	SC EnDat		9	
	SC SSI		11	
	SC BiSS*		17	
	EnDat	Linear absolute encoder	8	4
	SSI		10	5
BiSS*	13		6	

#### Linear Quadrature / SinCos Encoder

These types of encoder are purely incremental and have no information for commutation. With this type of feedback the drive must carry out a phasing test to find the phase offset angle on every power up for operation in RFC-S mode.

#### Digital Hall Effect + Linear Quadrature / SinCos Incremental encoder

These types of encoder have digital hall effect signals U, V, W plus complements that supply the necessary signals for deriving the position at power-up. The quadrature signals, incremental or SinCos are used for speed feedback. A flux alignment test is required during set-up to determine the phase offset angle for operation in RFC-S mode.

#### Linear Absolute SinCos encoder

These types of encoder derive the absolute position at power-up via the comms protocol, Hiperface, EnDat or SSI with the incremental signals, SinCos, being used for incremental position and speed feedback. A flux alignment test is required during set-up to determine the phase offset angle for operation in RFC-S mode.

#### Linear Absolute encoder

These types of feedback are comms only encoders, which derive the position at power-up via either the EnDat or SSI comms protocols. The position feedback is also passed via comms during operation. The comms only encoders operate with the drive being the master and passing the required clock signal. A flux alignment test is required during set-up to determine the phase offset angle for operation in RFC-S mode.

#### NOTE

Refer to section 3.4.2 *SinCos encoder feedback signals* on page 12 for further information on the SinCos encoder feedback signals.

\* BiSS is not currently supported.

Limitations				
Type	Encoder	Max input frequency	Max no. of lines	Max baud rate
Linear encoder	AB	500 kHz	100,000	9600 bits/sec
	AB Servo			
	SC			
	SC Servo	See Table 3-2 <i>Interpolated information based on frequency and voltage level on page 13</i>		4 Mbits/sec
	SC Hiperface			
	SC EnDat			
	SC SSI			
	SC BiSS*			
	EnDat			
	SSI			
BiSS*				

**NOTE**

In some applications using RFC-A control, the maximum speed of the system is above the speed at which the encoder feedback frequency is too high to be used by the drive. For these types of applications Pr **03.024** RFC Feedback should be set to 2 (Feedback NoMax) for low speed operation and 3 (Sensorless NoMax) for high-speed operation. It should be noted that the drive no longer checks that the maximum encoder frequency cannot be exceeded, and therefore the user must ensure that Pr **03.024** is set to 3 before the encoder frequency limit is reached.

**3.4.7 Drive firmware compatibility**

The SI-Universal Encoder module is compatible with the Unidrive M600 to M702 range of drives. The recommended drive firmware version is V01.09.00.00 or later.

**3.5 Encoder feedback selection**

**3.5.1 Encoder selection**

The SI-Universal Encoder module supports a total of 15 encoder types. These range from Quadrature relative encoders to Quadrature plus Commutation, SinCos plus Comms and Comms only absolute encoders.

When selecting an encoder there are essentially two groups these being absolute and relative. Absolute encoders providing the absolute position at power-up to the drive and only requiring a phasing test during the initial set-up when used for RFC-S operation. Relative encoders requiring a phasing test at every power up when used for RFC-S operation.

Either absolute or relative encoders can be used for RFC-A operation.

**Absolute encoders**

The absolute encoders which are compatible with drive are as follows:

- AB Servo, FD Servo, FR Servo, SC Servo
- SC Hiperface, SC EnDat, SC SSI, SC BiSS\*
- EnDat, SSI, BiSS\*

**Non absolute encoders**

At power up the encoder counters will start to increment from the incremental position as the encoder rotates, the position is reset to zero on detection of the first marker.

Compatible relative encoders being:

AB, FD, FR, SC

\* BiSS is not currently supported.

### 3.5.2 Standard feedback

Basic encoder (AB, FD, FR)

- 6 wire (+ 2 for marker if required)
- Up to 100,000 ppr
- AB - quadrature signals (best noise immunity)
- FD - frequency and direction
- FR - forward and reverse
- Marker input (only connect if needed, low noise immunity)
- Freeze based directly on the encoder counter
- Termination control (P1 Interface Only)
- Wirebreak detection (P1 Interface Only)

#### NOTE

A quadrature encoder will provide sufficient performance for most applications once tuned.

#### Servo encoders (AB Servo, FD Servo, FR Servo, SC Servo)

- 12 wire (+ 2 for marker if required)
- Reduced maximum torque until two valid changes
- AB, FD, FR and SC signals used for motor control and speed feedback.
- Marker input (optional)
- Freeze based directly on the encoder counter
- Termination control (not for commutation signals)
- Wirebreak detection
- Phase error detection based on commutation signals
- P1 interface only

#### Non-absolute SINCOS encoder (SC)

- 6 wire
- Nominally the feedback resolution is sine waves per revolution plus 9 additional bits of interpolation information
- High resolution speed feedback, generally for induction motors but also servo motors
- Marker input
- Freeze is based on the time of the freeze event and interpolation between samples
- Wirebreak detection
- Initialization required to align the analog signals with the encoder counter
- P1 interface only

### 3.5.3 High resolution feedback

#### Stegmann Hiperface SINCOS encoders (SC Hiperface)

- 8 wire
- 8 - 12 V supply
- Absolute position determined via asynchronous comms
- Nominally the feedback resolution is sine waves per revolution plus 9 additional bits of interpolation information
- No marker input
- Freeze is based on the time of the freeze event and interpolation between samples
- Wirebreak detection
- Auto-configuration is possible
- Encoder phase error detection using comms
- Comms includes message XOR checksum
- Initialization required to obtain the absolute position via comms and to align the analog signals with the encoder counter
- P1 interface only

**NOTE**

An SC Hiperface encoder will provide high performance and is recommended for precision applications.

**Heidenhain EnDat SINCOS encoders (SC EnDat)**

- 10 wire
- 5 V supply
- Absolute position determined via synchronous comms
- Nominally the feedback resolution is sine waves per revolution plus 9 additional bits of interpolation information
- No marker input
- Freeze is based on the time of the freeze event and interpolation between samples
- Wirebreak detection
- Encoder phase error detection using comms
- Comms includes CRC check
- Auto-configuration is possible
- Initialization required to obtain the absolute position via comms and to align the analog signals with the encoder counter
- Encoder cable length compensation allowing high baud rates with long encoder cables.
- P1 interface only

**NOTE**

An SC EnDat encoder will provide high performance and is recommended for precision applications.

**SSI SINCOS encoders (SC SSI)**

- 10 wire
- Absolute position determined via synchronous comms
- Nominally the feedback resolution is sine waves per revolution plus 9 additional bits of interpolation information
- No marker input
- Freeze is based on the time of the freeze event and interpolation between samples
- Wirebreak detection
- Auto-configuration is not possible
- Encoder phase error detection using comms
- The comms protocol does not include any error checking
- Initialization required to take the absolute position via comms and to align the analog signals with the encoder counter
- Gray code or binary format encoders
- Power supply fail bit monitoring
- P1 interface only

**SSI only encoder (SSI)**

- 6 wire
- Position obtained via synchronous comms
- Not auto configurable, no error checking, too slow for use as motor feedback
- Feedback resolution defined by comms resolution
- No marker input
- Freeze is based on the time of the freeze event and interpolation between samples
- Wirebreak detection by comms error
- Gray code or binary format encoders
- Power supply fail bit monitoring

How to use this guide	Safety information	Introduction	Mechanical installation	Electrical installation	Getting started	Parameters	Advanced operation	Diagnostics	Terminal data	Index
-----------------------	--------------------	--------------	-------------------------	-------------------------	-----------------	------------	--------------------	-------------	---------------	-------

**NOTE**

SSI only encoders are not recommended for use as motor feedback, but can be used for either positioning or reference.

**EnDat only encoders (EnDat)**

- 6 wire
- Position obtained via synchronous comms
- Feedback resolution defined by comms resolution
- No marker input
- Freeze is based on the time of the freeze event and interpolation between samples
- Wirebreak detection by comms error
- Comms includes CRC check
- Auto-configuration is possible
- Compatible with EnDat 2.1 and EnDat 2.2
- Encoder cable length compensation allowing high baud rates with long encoder cables.

**NOTE**

An EnDat encoder will provide high performance and is recommended for precision applications.

**BiSS SINCOS encoders (SC BiSS)\***

- 10 wire
- 5 V to 15 V supply
- Absolute position determined via synchronous comms
- Nominally the feedback resolution is sine waves per revolution plus 9 additional bits of interpolation information
- No marker input
- Freeze is based on the time of the freeze event and interpolation between samples
- Wirebreak detection
- Encoder phase error detection using comms
- Comms includes CRC check
- Partial auto-configuration is possible
- Initialization required to obtain the absolute position via comms and to align the analog signals with the encoder counter
- Encoder cable length compensation allowing high baud rates with long encoder cables.

**NOTE**

A SC BiSS encoder will provide high performance and is recommended for precision applications

**BiSS only encoders (BiSS)\***

- 6 wire
- 5 V to 15 V supply
- Position obtained via synchronous comms
- Feedback resolution defined by comms resolution
- No marker input
- Freeze is based on the time of the freeze event and interpolation between samples
- Wirebreak detection by comms error
- Comms includes CRC check
- Partial auto-configuration is possible
- Compatible with BiSS C Mode.
- Encoder cable length compensation allowing high baud rates with long encoder cables.

**NOTE**

A BiSS encoder will provide high performance and is recommended for precision applications

\* BiSS is not currently supported.

## 3.6 Considerations

When selecting an encoder, there are a number of considerations, these being application, drive operation, and encoder specification dependant.

### 3.6.1 Application dependant

1. Operating mode
2. Is the application a positioning application where high resolution is required?
3. Is absolute position required at every power up, for example for operation in servo mode where a phasing test is not possible at every power-up?
4. What resolution is required (e.g. AB 1024 encoder = 10bit resolution, SC Hiperface 1024 = 19 bit resolution)?
5. What environment is the encoder to be installed in?
6. What cable lengths are to be used?
7. Encoder supply voltage should be selected dependant upon the cable lengths due to voltage drop
8. Are motor objects to be saved to the encoder?

### 3.6.2 Drive operation dependant

1. When operating in RFC-S mode the drive requires the absolute position at power-up, be this from an absolute encoder or through a phasing test at every power-up
2. When operating in RFC-A either an absolute or non-absolute encoder can be used
3. Encoder power supply and loading when operating with long cable lengths

### 3.6.3 Encoder specification dependant

1. Encoder voltage levels, are these compatible with the drive?
2. Incremental encoder signals are these compatible (SC, AB, FR, FD)?
3. Incremental signals do not exceed maximum input frequency for option module
4. Comms encoder protocol is compatible (Hiperface, EnDat, SSI, BiSS\*)
5. Comms encoder baud rate is compatible with drive
6. Application cable lengths do not exceed incremental signals cable length
7. Application cable lengths do not exceed the recommended cable length for comms operation, this being baud rate specific
8. Encoder loading does not exceed encoder power supply from module (external power supply should be used if this is the case)

### 3.6.4 Drive resolution / Feedback accuracy

The following values calculated are not a direct representation of performance at the motor shaft, with the motors inductance and load inertia smoothing out the shaft value to a much lower level. The value calculated is the instantaneous change in the internal speed feedback value seen by the drive between sample periods, and when the number of counts per revolution changes by 1 count. This change is due to at any given speed it is unlikely that the number of counts per sample period will always be a whole number e.g. 1 in 10 sample periods may have an extra pulse to ensure the average speed is as demanded.

\* BiSS is not currently supported.

### 3.6.5 Available resolution

#### NOTE

The following Quadrature and SinCos type incremental encoders are available with various lines per revolution with the drive being compatible with encoders ranging from 1 PPR (4 CPR) to 100,000 PPR (400,000CPR).

The comms only encoders which include both EnDat, BiSS\* and SSI are also available with various comms resolutions with drive being compatible up to 32 bits

#### AB Quadrature Incremental Encoder

- A 4096 LPR encoder has 4096 pulses per channel, and 16,384 edges. Available resolution = 16,384 counts / turn.

#### SC Incremental Encoder

- An SCS50 SinCos encoder has 1024 sine waves per revolution with the drive interpolating each sine wave to 9 bits worth of resolution giving a total resolution of  $2 \times 1024 \times 2^9 = 1,048,576$  counts per revolution

#### EnDat Comms Only Encoder

- An EnDat comms only encoder has 25 bits giving a total resolution of = 33554432 counts per revolution

Comparing a 4096 PPR incremental encoder to a SCS50 SinCos encoder, the SCS50 SinCos encoder will have a factor of 128 less ripple than the 4096 PPR encoder.

Therefore the encoder selected can influence the digital torque ripple significantly and should be considered on high resolution / accuracy applications.

### 3.6.6 Internal digital torque ripple calculation

Following is an example of the internal digital torque ripple calculation

AB Quadrature Encoder

1024 line encoder running at 1500 rpm and drive speed loop sample time = 250  $\mu$ s

- 1500 rpm / 60 s = 25 rev/s
- 25 rev / s x 1024 ppr = 25600 pulses/s
- 25600 pulses / s x 4 edges = 102400 edges/s
- 102400 edges / s x 250 x 10<sup>-6</sup> = 25.6 edges per sample period

Therefore due to the digitisation of the encoder feedback the average number of edges seen will be 25.6, but this must be due to the relevant number of 25 and 26 edges over an infinite length of time. As such:

$$25 \text{ edges} / 250 \times 10^{-6} = 100,000 \text{ edges/sec.}$$

$$100,000 / 4 = 25,000 \text{ pulses}$$

$$25,000 / 1024 = 24.4 \text{ rev/s}$$

$$24.4 \times 60 = 1464.8 \text{ rpm}$$

$$26 \text{ edges} / 250 \times 10^{-6} = 104,000 \text{ edges/sec.}$$

$$104,000 / 4 = 26,000 \text{ pulses}$$

$$26,000 / 1024 = 25.4 \text{ rev/s}$$

$$25.4 \times 60 = 1523.4 \text{ rpm}$$

$$1523 - 1464 = 59 \text{ rpm}$$

The difference of 1 pulse gives an instantaneous speed change of 59 rpm.

\* BiSS is not currently supported.



## 4 Mechanical Installation



Before installing or removing an option module from any drive, ensure the AC supply has been disconnected for at least 10 minutes and refer to section 2 *Safety information* on page 7. If using a DC bus supply ensure this is fully discharged before working on any drive or option module.

### 4.1 General installation

Installation of an option module is illustrated in Figure 4-1.

Figure 4-1 Installing an option module on Unidrive M600 to M700

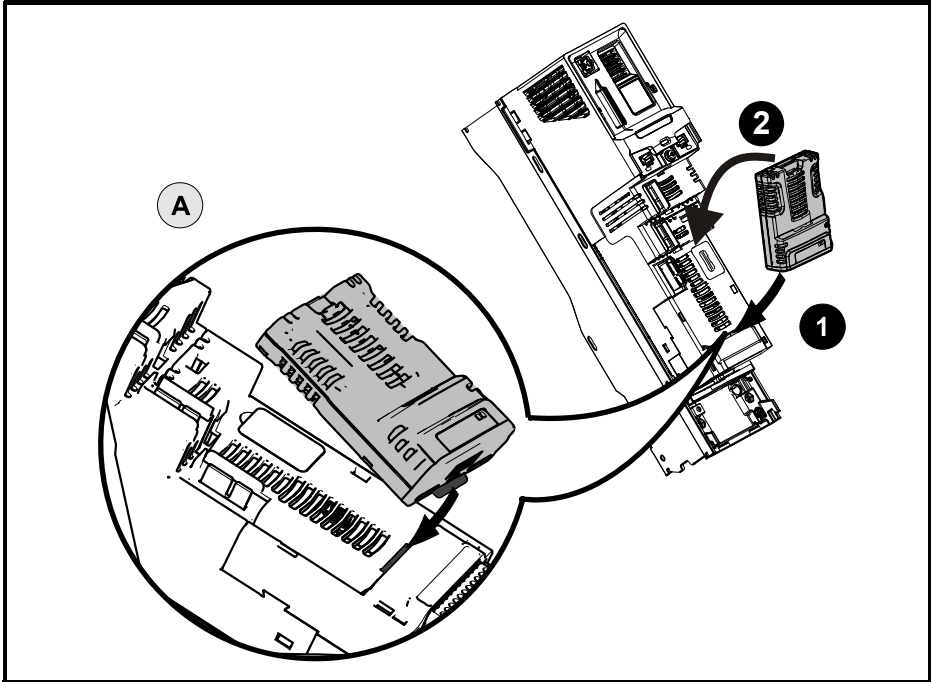

Option module slots must be used in the following order: (Slot 3), (Slot 2) then (Slot 1).

- Move the option module in the direction shown (1/2).
- Align and insert the option module tab into the slot provided. This is highlighted in the detailed view (A).
- Press down on the option module until it clicks into place.

How to use this guide
Safety information
Introduction
<b>Mechanical installation</b>
Electrical installation
Getting started
Parameters
Advanced operation
Diagnostics
Terminal data
Index

---

## 5 Electrical installation

---

### 5.1 Basic Functions

The following functions are provided via the 15-way high density D-type connector and a 10-way pluggable connector on the drive:

- Two position feedback interfaces (P1 and P2).
- One encoder simulation output.
- Two freeze trigger inputs (marker inputs).
- One thermistor input.

The P1 position interface is always available but the availability of the P2 position interface and the encoder simulation output depends on the position feedback device used on the P1 position interface.

#### 5.1.1 Compatible position feedback devices

**Table 5-1 Supported feedback devices on the P1 position interface**

Encoder type	Pr 1x.038 setting
Quadrature incremental encoders with or without marker pulse	AB (0)
Quadrature incremental encoders with UVW commutation signals for absolute position for permanent magnet motors with or without marker pulse	AB Servo (3)
Forward / reverse incremental encoders with or without marker pulse	FR (2)
Forward / reverse incremental encoders with UVW commutation signals for absolute position for permanent magnet motors with or without marker pulse	FR Servo (5)
Frequency and direction incremental encoders with or without marker pulse	FD (1)
Frequency and direction incremental encoders with UVW commutation signals for absolute position for permanent magnet motors with or without marker pulse	FD Servo (4)
Sincos incremental encoders with or without marker pulse	SC (6)
Sincos incremental with commutation signals with or without marker pulse	SC Servo (12)
Heidenhain sincos encoders with EnDat comms for absolute position	SC EnDat (9)
Stegmann sincos encoders with Hiperface comms for absolute position	SC Hiperface (7)
Sincos encoders with SSI comms for absolute position	SC SSI (11)
Sincos encoders with BiSS comms for absolute position (not currently supported)	SC BiSS (17)*
SSI encoders (Gray code or binary)	SSI (10)
EnDat communication only encoders	EnDat (8)
BiSS communication only encoders (not currently supported)	BiSS (13)*

\* BiSS is not currently supported.

**Table 5-2 Supported feedback devices on the P2 position interface**

Encoder type	Pr 2x.038 setting
Quadrature incremental encoders with or without marker pulse	AB (1)
Frequency and direction incremental encoders with or without marker pulse	FD (2)
Forward / reverse incremental encoders with or without marker pulse	FR (3)
EnDat communication only encoders	EnDat (4)
SSI encoders (Gray code or binary)	SSI (5)
BiSS communication only encoders (not currently supported)	BiSS (6)*

Table 5-3 shows the possible combinations of position feedback device types connected to the P1 and P2 position interfaces and the availability of the encoder simulation output.

**Table 5-3 Availability of the P2 position feedback interface and the encoder simulation output**

Functions		
P1 Position feedback interface	P2 Position feedback interface	Encoder Simulation Output
AB Servo FD Servo FR Servo SC Servo		
AB FD FR SC SC Hiperface	AB, FD, FR EnDat, BiSS, SSI	
		Full
SC EnDat SC SSI SC BiSS*	AB, FD, FR (No Z marker pulse input) EnDat, BiSS*, SSI (with freeze input)	
		No Z marker pulse output
EnDat BiSS* SSI	AB, FD, FR EnDat, BiSS*, SSI	
		Full
	EnDat, BiSS*, SSI	No Z marker pulse output

The priority of the position feedback interfaces and the encoder simulation output on the 15-way D-type is assigned in the following order from the highest priority to the lowest.

- P1 position interface (highest)
- Encoder simulation output
- P2 position interface (lowest)

\* BiSS is not currently supported.

How to use this guide
Safety information
Introduction
Mechanical installation
<b>Electrical installation</b>
Getting started
Parameters
Advanced operation
Diagnostics
Terminal data
Index

For example, if an AB Servo type position feedback device is selected for use on the P1 position interface, then both the encoder simulation output and the P2 position interface will not be available as this device uses all connections of the 15-way D-type connector. Also, if an AB type position feedback device is selected for use on the P1 position interface and Pr **1x.085** is set to a valid source for the encoder simulation output, then the P2 position interface will not be available.

Depending on the device type used on the P1 position interface, the encoder simulation output may not be able support a marker pulse output (e.g. SC EnDat or SC SSI device types). Pr **1x.086** shows the status of the encoder simulation output indicating whether the output is disabled, no marker pulse is available or full encoder simulation is available.

**NOTE**

When using the P1 and P2 position interfaces and the encoder simulation output together, the P2 position interface uses alternative connections on the 15-way D-type connector. Pr **2x.072** shows the status of the P2 position interface and indicates if alternative connections are being used for the P2 position interface.

## 5.1.2 Terminal descriptions

**Table 5-4 Terminal information**



**Table 5-5 P1 Interface connection details**

Terminal		Encoder													
15 way D-type connector	10 way pluggable connector	AB	FD	FR	AB Servo	FD Servo	FR Servo	SC	SC Hiperface	EnDat	SC EnDat / SC BISS*	SSI	SC SSI	SC Servo	BISS*
1		A	F		A	F	F	A (Cos)	Cos	DATA	A	DATA	A (Cos)		DATA
2		A\	F\		A\	F\	F\	A\ (Cos\)	CosRef	DATA\	A\	DATA\	A\ (Cos\)		DATA\
3		B	D		B	D	R	B (Sin)	Sin	CLK	B	CLK	B (Sin)		CLK
4		B\	D\		B\	D\	R\	B\ (Sin\)	SinRef	CLK\	B\	CLK\	B\ (Sin\)		CLK\
5		Z							DATA	Freeze 1	DATA	Freeze 1	DATA	Z	P2/ Freeze1
6		Z\							DATA\	Freeze 1\	DATA\	Freeze 1\	DATA\	Z\	P2/ Freeze1\
7	3	P2 / Enc. Sim. Out			U			P2 / Enc. Sim. Out					U	P2 / Enc. Sim. Out	
8	4	P2 / Enc. Sim. Out			U\			P2 / Enc. Sim. Out					U\	P2 / Enc. Sim. Out	
9	5	P2 / Enc. Sim. Out			V			P2 / Enc. Sim. Out					V	P2 / Enc. Sim. Out	
10	6	P2 / Enc. Sim. Out			V\			P2 / Enc. Sim. Out					V\	P2 / Enc. Sim. Out	
11	8	P2 / Enc. Sim. Out			W			P2 / Enc. Sim. Out			CLK	P2 / Enc. Sim. Out	CLK	W	P2 / Enc. Sim. Out
12	9	P2 / Enc. Sim. Out			W\			P2 / Enc. Sim. Out			CLK\	P2 / Enc. Sim. Out	CLK\	W\	P2 / Enc. Sim. Out
13	10	+V (Power Supply Output)													
14	2, 7	0V													
15		Thermistor													
	1	+ 24 V Freeze Input													

\* BISS is not currently supported.

**Table 5-6 P2 Interface and simulated encoder output connection details**

Terminal		P2 Interface				Encoder Simulation Output			
15 way D-type connector	10 way pluggable connector	AB	FD	FR	EnDat SSI BiSS	AB	FD	FR	SSI
7	3	A	F	F	DATA	Asim	Fsim	Fsim	DATAsim
8	4	A\	F\	F\	DATA\	Asim\	Fsim\	Fsim\	DATAsim\
9	5	B	D	R	CLK	Bsim	Dsim	Rsim	CLKsim
10	6	B\	D\	R\	CLK\	Bsim\	Dsim\	Rsim\	CLKsim\
11	8	Z			Freeze2	Zsim			
12	9	Z\			Freeze2 \	Zsim\			

When the EnDat, SSI or BiSS\* type position feedback device is selected for use on the P1 interface and the encoder has no freeze inputs, it is possible to use P1 and P2 position interface and the encoder simulation output together, the P2 position interface uses alternative connections on the 15-way D-type connector. Pr **2x.072** shows the status of the P2 position interface and indicates if alternative connections are being used for the P2 position interface.

**Table 5-7 P2 Interface and simulated encoder output connection details when P1 interface is EnDat, SSI or BiSS\* with no freeze inputs.**

Terminal		P2 Interface		Encoder Simulation Output				
15 way D-type connector	10 way pluggable connector	EnDat Alt	SSI Alt	BiSS Alt	AB	FD	FR	SSI
5		DATA						
6		DATA\						
7	3				Asim	Fsim	Fsim	DATAsim
8	4				Asim\	Fsim\	Fsim\	DATAsim\
9	5				Bsim	Dsim	Rsim	CLKsim
10	6				Bsim\	Dsim\	Rsim\	CLKsim\
11	8	CLK						
12	9	CLK\						

\* BiSS is not currently supported.

## 5.2 Wiring, Shield connections

Shielding considerations are important for PWM drive installations, due to the high voltages and currents present in the output circuit with a wide frequency spectrum, typically from 0 to 20 MHz. Encoder inputs are liable to be disturbed if careful attention is not given to the physical management of the cable shields.

### Encoder mounting methods

There are three methods for mounting an encoder on the motor:

1. Galvanic isolation between encoder and motor
2. Galvanic isolation between encoder circuit and encoder body
3. No Isolation

#### 5.2.1 Encoder with galvanic isolation from motor

When galvanically isolated the encoder device is mounted to the motor with isolation installed between the motor housing / shaft and encoder as shown in Figure 5-1.

**Figure 5-1 Galvanic Isolation**

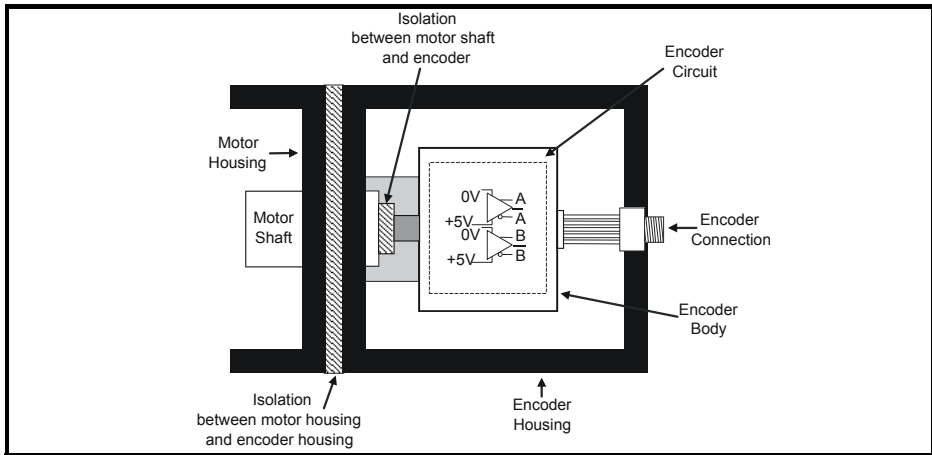

An example of this is the Unimotor, where isolation from the motor is achieved by inserting a plastic mounting plate between the motor housing and encoder housing and a plastic insert fitted in the motor shaft for encoder mounting to the motor shaft. With this preferred method of mounting, noise currents are prevented from passing from the motor housing into the encoder housing, and hence into the encoder cable.

The ground connection of the cable shield is optional, but this may be required in order to comply with safety measures, or to reduce radiated radio frequency emissions from either the drive or encoder.

### 5.2.2 Encoder circuit with galvanic isolation from encoder body

In this case, the encoder device is mounted directly on the motor housing with contact being made between the motor housing/shaft and encoder. With this mounting method, the encoders internal circuits are exposed to electrical noise from the motor housing through the stray capacitance, and must therefore be designed to withstand this situation. However, this arrangement still prevents large noise currents from flowing from the motor body into the encoder cable.

The ground connection of the cable shield is optional, this may be required to comply with safety measures or to reduce radiated radio frequency emissions from either the drive or encoder.

How to use this guide
Safety Information
Introduction
Mechanical Installation
<b>Electrical Installation</b>
Getting started
Parameters
Advanced operation
Diagnostics
Terminal data
Index

**Figure 5-2 Encoder galvanically isolated from encoder body**

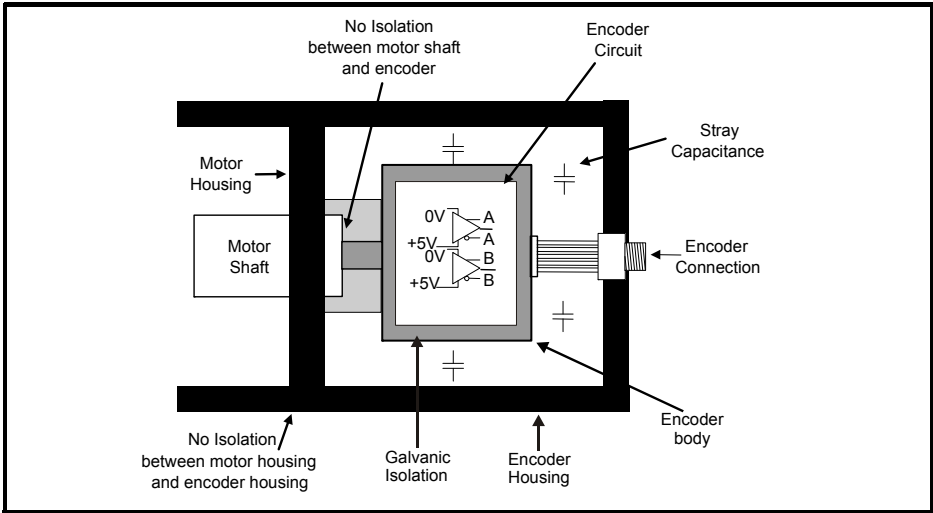

**5.2.3 No isolation**

As shown in Figure 5-3, the encoder 0V connection may be permanently connected to the housing. This has the advantage that the encoder body can form a shield for its internal circuits. However this permits noise current from the motor body to flow into the encoder cable shield. The use of high quality shielded cable correctly terminated, will help protect the data against induced noise, but a greater level of care must be taken to ensure good cable management than would be used for example in isolated cases.

**Figure 5-3 No isolation**

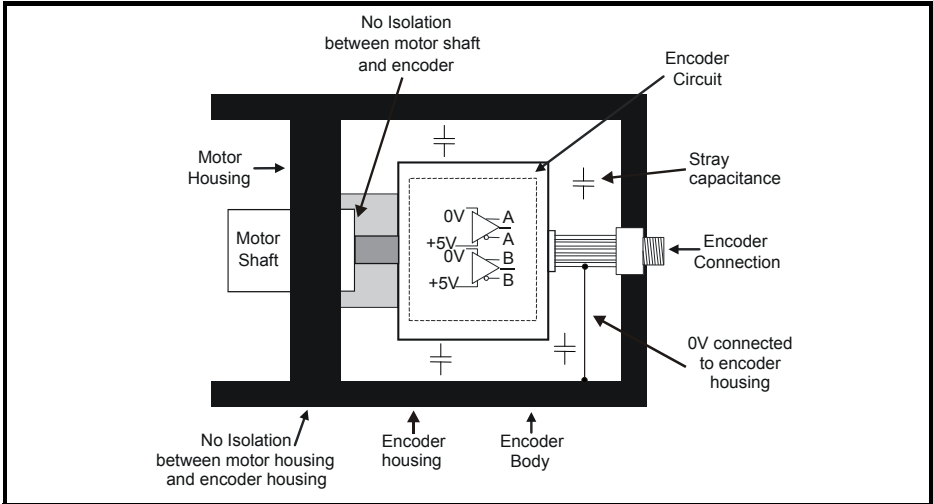



## 5.2.4 Cable requirements

### All mounting methods:

- Shield connection at drive terminal to 0V
- Shield connection at encoder to 0V
- It is recommended that the shielded cable should be run in a continuous length to the terminal, to avoid the injection of noise at intermediate pigtails and to maximise the shielding benefit.
- The shield connections ("pigtails") to the drive and encoder should be kept as short as possible

### Mounting with no isolation:

- Shield connected to ground at both ends. The connection must be made by direct fixing of the cable to the grounded metal parts, i.e. to the encoder body and the drive grounding bracket as shown in Figure 5-5 on page 34, "Pigtails" must be avoided. The outer sheath of the cable should be stripped back enough to allow for the ground clamp to be installed. The shield connection should not be broken. The ground clamps should be located as close as possible to the drive and encoder.
- It is essential that the shielded cable should be run in a continuous length to the terminal, to avoid the injection of noise at intermediate "pigtails" and to maximise the shielding benefit.



Under no circumstances should the cable shield connection be omitted at any end of the cable, since the noise voltage may well be sufficient to destroy the line driver and receiver chips in the encoder and the drive.

### Cable shield ground connection

For all mounting methods, grounding of the feedback cable shield has added benefits. It can protect the drive and encoder from induced fast electrical transients, and prevent radiated radio-frequency emission. However it is essential that it be carried out in the correct manner as explained above and as shown in Figure 5-5.



Connecting the cable shield to ground at both ends carries the risk that an electrical fault might cause excessive power current to flow in the cable shield and overheat the cable. There must be an adequately rated safety ground connection between the motor/encoder and the drive.

### Recommended Cable

The recommended cable for feedback signals is a twisted pair, shielded with an overall shield as shown below.

**Figure 5-4 Feedback cable, twisted pair**

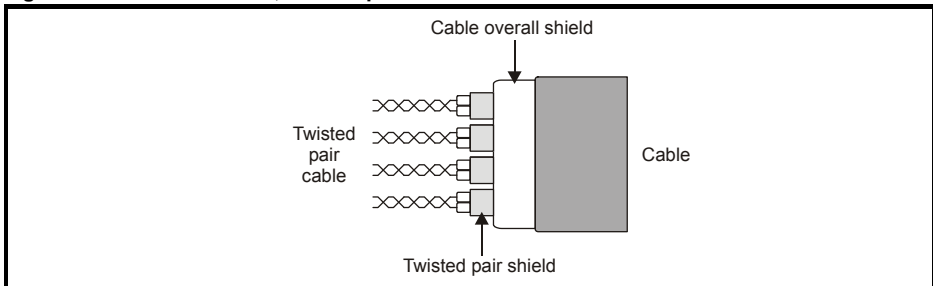

Using this type of cable allows for the connection of the outer shield to ground and the inner shields to 0V at both the drive and encoder.

#### NOTE

Ensure that feedback cables are kept as far away as possible from power cables and avoid parallel routing.

**Figure 5-5 Feedback cable connections**

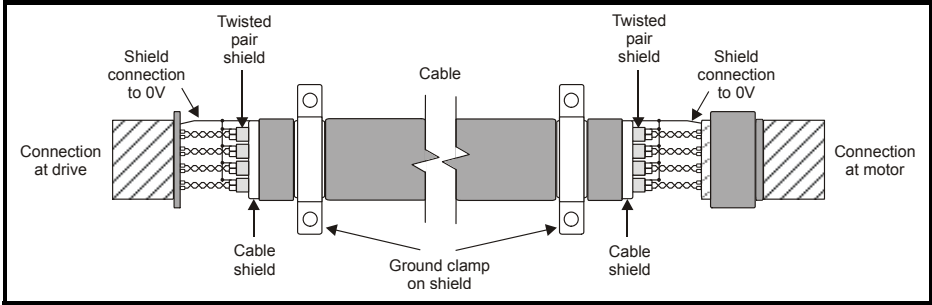

# 6 Getting started

## 6.1 Installation



The control circuits are isolated from the power circuits in the drive by basic insulation only as specified in IEC60664-1. The installer must therefore ensure that the external control circuits are insulated from human contact by at least one layer of insulation rated for use at the AC supply voltage.

If the control circuits are to be connected to other circuits classified as Safety Extra Low Voltage (SELV) (e.g. to a personal computer) an additional isolating barrier must be included in order to maintain the SELV classification.

### Encoder connections

In order to ensure correct operation there are a number of checks which should be carried out:

- Ensure the encoder is securely mounted to the motor as spurious operation can result due to the encoder slipping whilst the motor is rotating.
- Ensure encoder connections to both the encoder and the option module terminals are secure. Intermittent connections can result in spurious operation or the option module not detecting the feedback signals.
- Ensure the shielding recommendations as specified in section 5.2 *Wiring, Shield connections* on page 30 are followed to prevent noise being induced in the encoder feedback signals. Noise induced in the encoder feedback cables can result in spurious operation, and in extreme cases can result in encoder failure and/or damage to the option modules encoder input.

Encoder feedback is transmitted from an encoder as low voltage digital signals. Ensure that electrical noise from the drive or motor does not adversely affect the encoder feedback. Ensure that the drive and motor are connected in accordance with the instructions given in the appropriate *Power Installation Guide*. Also verify that the encoder feedback wiring and shielding recommendations are followed in section 5.2 *Wiring, Shield connections* on page 30.

## 6.2 Setting up a feedback device

### 6.2.1 P1 position interface

The parameter settings which must be made to utilize each of the compatible feedback device types with the P1 position interface on the drive are described here. For more information regarding these parameters refer to section 7 *Parameters* on page 48.

If the position feedback device connected to the P1 position interface is required to be used for motor control feedback, then Pr **03.026** on the drive will need to be set to P1 SlotX (where X is the slot in which the module is installed).

How to use  
this guide

Safety  
information

Introduction

Mechanical  
Installation

Electrical  
Installation

Getting  
started

Parameters

Advanced  
operation

Diagnostics

Terminal data

Index

**Table 6-1 Parameters required for feedback device set-up on the P1 position interface**

Parameter	AB, FD, FR, AB Servo, FD Servo, FR Servo, SC, SC Servo	SC Hiperface	SC EnDat	SC BiSS**	EnDat	SC SSI	SSI	BiSS**
<i>P1 Marker Mode (1x.031)</i>	✓							
<i>P1 Rotary Turns Bits (1x.033)</i>		●	●	●	●	✓	✓	✓
<i>P1 Rotary Lines Per Revolution (1x.034)</i>	✓	●	●	●		✓		
<i>P1 Comms Bits (1x.035)</i>		●	●	●	●	✓	✓	✓
<i>P1 Supply Voltage (1x.036)*</i>	✓	✓	✓	✓	✓	✓	✓	✓
<i>P1 Comms Baud Rate (1x.037)</i>			✓	●	✓	✓	✓	●
<i>P1 Device Type (1x.038)</i>	✓	✓	✓	✓	✓	✓	✓	✓
<i>P1 Auto-configuration Select (1x.041)</i>		✓	✓	✓	✓			✓
<i>P1 SSI Binary Mode (1x.048)</i>						✓	✓	

✓ Information to be entered by user.

● Parameters can be set-up automatically by the drive using the auto-configuration parameter. This must be set by the user if auto-configuration is disabled (i.e. Pr **1x.041** = Disabled (0)).

\* **1x.036**: If the output voltage from the encoder is >5V, then termination resistors must be disabled by setting Pr **1x.039** to 0.

\*\* BiSS is not currently supported.

Table 6-1 shows a summary of the parameters required to set-up each feedback device.

## 6.2.2 P1 position interface: Detailed feedback device commissioning & start-up

Standard quadrature encoder with or without commutation signals (A, B, Z or A, B, Z, U, V, W), or Sincos encoder with or without UVW commutation signals

<i>Device Type (1x.038)</i>	<b>AB</b> (0) for a quadrature encoder without commutation signals* <b>AB Servo</b> (3) for a quadrature encoder with commutation signals <b>SC</b> (6) for a Sincos encoder without commutation signals* <b>SC Servo</b> (12) for a Sincos encoder with commutation signals																													
<i>Supply Voltage (1x.036)</i>	<b>5 V</b> (0), <b>8 V</b> (1) or <b>15 V</b> (2) <b>NOTE</b> If the output voltage from the encoder is >5 V the termination resistors must be disabled. Set Pr <b>1x.039</b> to 0.																													
<i>Rotary Line Per Revolution (1x.034)</i>	Set to the number of lines or sine waves per revolution of the encoder																													
<i>Termination Select (1x.039)</i> (AB or AB Servo only)	<b>0</b> = A, B, Z termination resistors disabled <b>1</b> = A, B termination resistors enabled and Z termination resistors disabled <b>2</b> = A, B, Z termination resistors enabled																													
<i>Marker Mode (1x.031)</i>	<table border="1"> <thead> <tr> <th colspan="4">Bit</th> <th rowspan="2">Description</th> </tr> <tr> <th>3</th> <th>2</th> <th>1</th> <th>0</th> </tr> </thead> <tbody> <tr> <td>X</td> <td>X</td> <td>X</td> <td>1</td> <td>No action is taken unless marker flag is zero before marker event occurs</td> </tr> <tr> <td>X</td> <td>X</td> <td>1</td> <td>X</td> <td>Pr <b>1x.028</b> and Pr <b>1x.058</b> are set to zero</td> </tr> <tr> <td>X</td> <td>1</td> <td>X</td> <td>X</td> <td>Pr <b>1x.028</b>, Pr <b>1x.029</b>, Pr <b>1x.030</b> and the related part of Pr <b>1x.058</b> are not reset. Pr <b>1x.058</b> is transferred to Pr <b>1x.059</b> and Pr <b>1x.032</b> is set to 1</td> </tr> <tr> <td>1</td> <td>X</td> <td>X</td> <td>X</td> <td>See section 7.2.3 <i>Menu 1x P1 Interface parameter descriptions</i> on page 55</td> </tr> </tbody> </table>	Bit				Description	3	2	1	0	X	X	X	1	No action is taken unless marker flag is zero before marker event occurs	X	X	1	X	Pr <b>1x.028</b> and Pr <b>1x.058</b> are set to zero	X	1	X	X	Pr <b>1x.028</b> , Pr <b>1x.029</b> , Pr <b>1x.030</b> and the related part of Pr <b>1x.058</b> are not reset. Pr <b>1x.058</b> is transferred to Pr <b>1x.059</b> and Pr <b>1x.032</b> is set to 1	1	X	X	X	See section 7.2.3 <i>Menu 1x P1 Interface parameter descriptions</i> on page 55
Bit				Description																										
3	2	1	0																											
X	X	X	1	No action is taken unless marker flag is zero before marker event occurs																										
X	X	1	X	Pr <b>1x.028</b> and Pr <b>1x.058</b> are set to zero																										
X	1	X	X	Pr <b>1x.028</b> , Pr <b>1x.029</b> , Pr <b>1x.030</b> and the related part of Pr <b>1x.058</b> are not reset. Pr <b>1x.058</b> is transferred to Pr <b>1x.059</b> and Pr <b>1x.032</b> is set to 1																										
1	X	X	X	See section 7.2.3 <i>Menu 1x P1 Interface parameter descriptions</i> on page 55																										
<i>Error Detection Level (1x.040)</i>	<table border="1"> <thead> <tr> <th colspan="5">Bit</th> <th rowspan="2">Description</th> </tr> <tr> <th>4</th> <th>3</th> <th>2</th> <th>1</th> <th>0</th> </tr> </thead> <tbody> <tr> <td>X</td> <td>X</td> <td>X</td> <td>X</td> <td>1</td> <td>Enable wire break detection</td> </tr> <tr> <td>X</td> <td>1</td> <td>X</td> <td>X</td> <td>X</td> <td>Disable trips <i>Encoder PS</i> to <i>SSI Error P1</i></td> </tr> <tr> <td>1</td> <td>X</td> <td>X</td> <td>X</td> <td>X</td> <td>Disable the <i>Setup changed P1</i> trip</td> </tr> </tbody> </table>	Bit					Description	4	3	2	1	0	X	X	X	X	1	Enable wire break detection	X	1	X	X	X	Disable trips <i>Encoder PS</i> to <i>SSI Error P1</i>	1	X	X	X	X	Disable the <i>Setup changed P1</i> trip
Bit					Description																									
4	3	2	1	0																										
X	X	X	X	1	Enable wire break detection																									
X	1	X	X	X	Disable trips <i>Encoder PS</i> to <i>SSI Error P1</i>																									
1	X	X	X	X	Disable the <i>Setup changed P1</i> trip																									

\* These settings should only be used in RFC-A mode. If used in RFC-S mode, a phase offset test must be performed after every power up.

How to use this guide
Safety Information
Introduction
Mechanical Installation
Electrical Installation
<b>Getting started</b>
Parameters
Advanced operation
Diagnostics
Terminal data
Index

**Incremental encoder with Frequency and Direction (F and D), or Forward and Reverse (CW and CCW) signals with or without commutation signals**

<i>Device Type (1x.038)</i>	<b>FD</b> (1) for frequency and direction signals without commutation signals* <b>FR</b> (2) for forward and reverse signals without commutation signals* <b>FD Servo</b> (4) for frequency and direction signals with commutation signals <b>FR Servo</b> (5) for forward and reverse signals with commutation signals				
<i>Supply Voltage (1x.036)</i>	<b>5 V</b> (0), <b>8 V</b> (1) or <b>15 V</b> (2) <b>NOTE</b> If output voltage from the encoder is >5 V, then the termination resistors must be disabled. Set Pr <b>1x.039</b> to 0				
<i>Rotary Line Per Revolution (1x.034)</i>	Set to the number of pulses per revolution of the encoder divided by 2				
<i>Termination Select (1x.039)</i>	0 = F and D/CW and CCW and Z termination resistors disabled 1 = F and D/CW and CCW termination resistors enabled and Z termination resistors disabled 2 = F and D/CW and CCW and Z termination resistors enabled				
<i>Marker Mode (1x.031)</i>	<b>Bit</b>				<b>Description</b>
	<b>3</b>	<b>2</b>	<b>1</b>	<b>0</b>	
	X	X	X	1	No action is taken unless marker flag is zero before marker event occurs
	X	X	1	X	Pr <b>1x.028</b> and Pr <b>1x.058</b> are set to zero
	X	1	X	X	Pr <b>1x.028</b> , Pr <b>1x.029</b> , Pr <b>1x.030</b> and the related part of Pr <b>1x.058</b> are not reset. Pr <b>1x.058</b> is transferred to Pr <b>1x.059</b> and Pr <b>1x.032</b> is set to 1
1	X	X	X	Undefined state region range is reduced from -30 mV to 30 mV. The marker pulse is only recognized if the pulse is 10 µs wide	
<i>Error Detection Level (1x.040)</i>	<b>Bit</b>				
	<b>4</b>	<b>3</b>	<b>2</b>	<b>1</b>	<b>0</b>
	X	X	X	X	1
	X	1	X	X	X
1	X	X	X	X	
<b>Description</b>					
Enable wire break detection					
Disable trips <i>Encoder PS</i> to <i>SSI Error P1</i>					
Disable the <i>Setup Changed P1</i> trip					

\* These settings should only be used in RFC-A mode. If used in RFC-S mode a phase offset test must be performed after every power up.

Absolute Sincos with Hiperface, EnDat, BiSS serial communication*, absolute EnDat, BiSS communication only*																																										
<i>Device Type (1x.038)</i>	<b>SC Hiperface (7)</b> for a Sincos encoder with Hiperface serial communications <b>EnDat (8)</b> for an EnDat communications only encoder <b>SC EnDat (9)</b> for a Sincos encoder with EnDat serial communications <b>BiSS* (13)</b> for a BiSS communication only encoder <b>SC BiSS* (17)</b> for a SinCos encoder with BiSS serial communications																																									
<i>Supply Voltage (1x.036)</i>	<b>5 V (0)</b> , <b>8 V (1)</b> or <b>15 V (2)</b>																																									
<i>Auto-configuration Select (1x.041)</i>	Auto-configuration is enabled at default and automatically sets up the following parameters. Rotary Turns Bits ( <b>1x.033</b> ) (not BiSS*) Rotary Lines Per Revolutions ( <b>1x.034</b> ) (not BiSS*) Comms Bits ( <b>1x.035</b> ) (not BiSS*) Comms Baud rate ( <b>1x.037</b> ) (BiSS* only) Calculation Time ( <b>1x.060</b> ) = 5 μs (BiSS* only) Recovery Time ( <b>1x061</b> ) = 13 μs (BiSS* only) These parameters can be entered manually when Pr <b>1x.041</b> is set to Disabled (0)																																									
<i>Comms Baud Rate (1x.037)</i>	100 k (0), 200 k (1), 300 k (2), 400 k (3), 500 k (4), 1 M (5), 1.5 M (6), 2 M (7), 4 M (8)																																									
<i>Error Detection Level (1x.040)</i>	<table border="1"> <thead> <tr> <th colspan="5">Bit</th> <th rowspan="2">Description</th> </tr> <tr> <th>4</th> <th>3</th> <th>2</th> <th>1</th> <th>0</th> </tr> </thead> <tbody> <tr> <td>X</td> <td>X</td> <td>X</td> <td>X</td> <td>1</td> <td>Enable wire break detection</td> </tr> <tr> <td>X</td> <td>X</td> <td>X</td> <td>1</td> <td>X</td> <td>Enable phase error detection</td> </tr> <tr> <td>X</td> <td>X</td> <td>1</td> <td>X</td> <td>X</td> <td>Enable SSI power supply alarm bit monitor</td> </tr> <tr> <td>X</td> <td>1</td> <td>X</td> <td>X</td> <td>X</td> <td>Disable trips <i>Encoder PS</i> to <i>SSI Error P1</i></td> </tr> <tr> <td>1</td> <td>X</td> <td>X</td> <td>X</td> <td>X</td> <td>Disable the <i>Setup changed P1</i> trip</td> </tr> </tbody> </table>	Bit					Description	4	3	2	1	0	X	X	X	X	1	Enable wire break detection	X	X	X	1	X	Enable phase error detection	X	X	1	X	X	Enable SSI power supply alarm bit monitor	X	1	X	X	X	Disable trips <i>Encoder PS</i> to <i>SSI Error P1</i>	1	X	X	X	X	Disable the <i>Setup changed P1</i> trip
	Bit					Description																																				
	4	3	2	1	0																																					
	X	X	X	X	1	Enable wire break detection																																				
	X	X	X	1	X	Enable phase error detection																																				
	X	X	1	X	X	Enable SSI power supply alarm bit monitor																																				
	X	1	X	X	X	Disable trips <i>Encoder PS</i> to <i>SSI Error P1</i>																																				
1	X	X	X	X	Disable the <i>Setup changed P1</i> trip																																					
e.g. to enable the wire break and phase error detection, set Pr <b>1x.040</b> to 00011.																																										

\* BiSS is not currently supported.

Absolute SSI communications only encoder, or Absolute Sincos encoder with SSI communications																																				
<i>Device Type (1x.038)</i>	SSI (10) for a SSI communications only encoder SC SSI (11) for a Sincos encoder with SSI serial communications																																			
<i>Supply Voltage (1x.036)</i>	5 V (0), 8 V (1) or 15 V (2)																																			
<i>Rotary Line Per Revolution (1x.034)</i>	Set the number of sine waves per revolution of the encoder																																			
<i>SSI Binary Mode (1x.048)</i>	Off = Gray Code On = Binary Mode																																			
<i>Rotary Turns Bits (1x.033)</i>	Set to the number of turns bits for the encoder (this is normally 12 bits for an SSI encoder)																																			
<i>Comms Bits (1x.035)</i>	Total number of bits of position information (this is usually 25 bits for an SSI encoder)																																			
<i>Comms Baud Rate (1x.037)</i>	100 k (0), 200 k (1), 300 k (2), 400 k (3), 500 k (4), 1 M (5), 1.5 M (6), 2 M (7), 4 M (8)																																			
<i>Error Detection Level (1x.040)</i>	<table border="1"> <thead> <tr> <th colspan="5">Bit</th> <th rowspan="2">Description</th> </tr> <tr> <th>4</th> <th>3</th> <th>2</th> <th>1</th> <th>0</th> </tr> </thead> <tbody> <tr> <td>X</td> <td>X</td> <td>X</td> <td>X</td> <td>1</td> <td>Enable wire break detection</td> </tr> <tr> <td>X</td> <td>X</td> <td>X</td> <td>1</td> <td>X</td> <td>Enable phase error detection</td> </tr> <tr> <td>X</td> <td>1</td> <td>X</td> <td>X</td> <td>X</td> <td>Disable trips <i>Encoder PS to SSI Error P1</i></td> </tr> <tr> <td>1</td> <td>X</td> <td>X</td> <td>X</td> <td>X</td> <td>Disable the <i>Setup Changed P1</i> trip</td> </tr> </tbody> </table>	Bit					Description	4	3	2	1	0	X	X	X	X	1	Enable wire break detection	X	X	X	1	X	Enable phase error detection	X	1	X	X	X	Disable trips <i>Encoder PS to SSI Error P1</i>	1	X	X	X	X	Disable the <i>Setup Changed P1</i> trip
	Bit					Description																														
4	3	2	1	0																																
X	X	X	X	1	Enable wire break detection																															
X	X	X	1	X	Enable phase error detection																															
X	1	X	X	X	Disable trips <i>Encoder PS to SSI Error P1</i>																															
1	X	X	X	X	Disable the <i>Setup Changed P1</i> trip																															
So for example, to enable the wire break and phase error detection, set Pr <b>1x.040</b> to 00011.																																				

### 6.2.3 P2 position interface

This section shows the parameter settings which must be made to use each of the compatible feedback device types with the P2 position interface on the drive. If the position feedback device connected to the P2 position interface is required to be used for motor control feedback then Pr **3.026** on the drive will need to be set to P2 SlotX where X is the slot number in which the module is installed.

**Table 6-2 Parameters required for feedback device set-up on the P2 position interface**

Parameter	AB, FD, FR	EnDat	SSI	BiSS*
<i>P2 Marker Mode (2x.031)</i>	✓			
<i>P2 Rotary Turns Bits (2x.033)</i>		●	●	✓
<i>P2 Rotary Lines Per Revolution (2x.034)</i>	✓			
<i>P2 Comms Bits (2x.035)</i>		●	●	✓
<i>P2 Comms Baud Rate (2x.037)</i>		✓	✓	●
<i>P2 Device Type (2x.038)</i>	✓	✓	✓	✓
<i>P2 Auto-configuration Select (2x.041)</i>		✓		✓

✓ Information to be entered by the user.



- Parameter can be set-up automatically by the drive through auto-configuration.
  - Parameter must be set by the user if auto-configuration is disabled (i.e. Pr **2x.041** = Disabled (0)).
- \* BiSS is not currently supported.

The P2 position interface does not have its own independent power supply output. Therefore any position feedback device connected to the P2 position interface must either share the P1 power supply output on pin 13 of the 15-way D-type and terminal 10 of the 10-way pluggable connector, or be supplied from an external source.

**NOTE**

The termination resistors are always enabled on the P2 position interface. Wire break detection is not available when using AB, FD or FR position feedback device types on the P2 position interface.

Table 6-2 shows a summary of the parameters required to set-up each feedback device.

Standard quadrature encoder (A, B, Z)					
<i>Device Type</i> <b>(2x.038)</b>	AB (1) for a quadrature encoder				
<i>Rotary Line Per Revolution</i> <b>(2x.034)</b>	Set to the number of lines per revolution of the encoder				
<i>Marker Mode</i> <b>(2x.031)</b>	Bit				Description
	<b>3</b>	<b>2</b>	<b>1</b>	<b>0</b>	
	X	X	X	1	No action is taken unless marker flag is zero before marker event occurs
	X	X	1	X	Pr <b>2x.028</b> and Pr <b>2x.058</b> are set to zero
	X	1	X	X	Pr <b>2x.028</b> , Pr <b>2x.029</b> , Pr <b>2x.030</b> and the related part of Pr <b>2x.058</b> are not reset. Pr <b>2x.058</b> is transferred to Pr <b>2x.059</b> and Pr <b>2x.032</b> is set to 1
1	X	X	X	Undefined state region range is reduced from -30 mV to 30 mV. The marker pulse is only recognized if the pulse is 10 µs wide.	
<i>Error Detection Level</i> <b>(2x.040)</b>	Bit				Description
	<b>4</b>	<b>3</b>	<b>2</b>	<b>1</b>	
	1	X	X	X	X

How to use this guide
Safety information
Introduction
Mechanical installation
Electrical installation
<b>Getting started</b>
Parameters
Advanced operation
Diagnostics
Terminal data
Index

<b>Incremental encoder with Frequency and Direction (F and D), or Forward and Reverse (CW and CCW) signals</b>																														
<b>Device Type (2x.038)</b>	FD (2) for frequency and direction signals without commutation signals FR (3) for forward and reverse signals without commutation signals																													
<b>Rotary Line Per Revolution (2x.034)</b>	Set to the number of pulses per revolution of the encoder divided by 2																													
<b>Marker Mode (2x.031)</b>	<table border="1"> <thead> <tr> <th colspan="4">Bit</th> <th rowspan="2">Description</th> </tr> <tr> <th>3</th> <th>2</th> <th>1</th> <th>0</th> </tr> </thead> <tbody> <tr> <td>X</td> <td>X</td> <td>X</td> <td>1</td> <td>No action is taken unless the marker flag is zero before the marker event occurs</td> </tr> <tr> <td>X</td> <td>X</td> <td>1</td> <td>X</td> <td>Pr <b>2x.028</b> and Pr <b>2x.058</b> are set to zero</td> </tr> <tr> <td>X</td> <td>1</td> <td>X</td> <td>X</td> <td>Pr <b>2x.028</b>, Pr <b>2x.029</b>, Pr <b>2x.030</b> and the related part of Pr <b>2x.058</b> are not reset. Pr <b>2x.058</b> is transferred to Pr <b>2x.059</b> and Pr <b>2x.032</b> is set to 1</td> </tr> <tr> <td>1</td> <td>X</td> <td>X</td> <td>X</td> <td>This bit has no effect</td> </tr> </tbody> </table>	Bit				Description	3	2	1	0	X	X	X	1	No action is taken unless the marker flag is zero before the marker event occurs	X	X	1	X	Pr <b>2x.028</b> and Pr <b>2x.058</b> are set to zero	X	1	X	X	Pr <b>2x.028</b> , Pr <b>2x.029</b> , Pr <b>2x.030</b> and the related part of Pr <b>2x.058</b> are not reset. Pr <b>2x.058</b> is transferred to Pr <b>2x.059</b> and Pr <b>2x.032</b> is set to 1	1	X	X	X	This bit has no effect
	Bit				Description																									
	3	2	1	0																										
	X	X	X	1	No action is taken unless the marker flag is zero before the marker event occurs																									
	X	X	1	X	Pr <b>2x.028</b> and Pr <b>2x.058</b> are set to zero																									
X	1	X	X	Pr <b>2x.028</b> , Pr <b>2x.029</b> , Pr <b>2x.030</b> and the related part of Pr <b>2x.058</b> are not reset. Pr <b>2x.058</b> is transferred to Pr <b>2x.059</b> and Pr <b>2x.032</b> is set to 1																										
1	X	X	X	This bit has no effect																										
<b>Error Detection Level (2x.040)</b>	<table border="1"> <thead> <tr> <th colspan="5">Bit</th> <th rowspan="2">Description</th> </tr> <tr> <th>4</th> <th>3</th> <th>2</th> <th>1</th> <th>0</th> </tr> </thead> <tbody> <tr> <td>1</td> <td>X</td> <td>X</td> <td>X</td> <td>X</td> <td>Disable <i>setup changed P2</i> trip</td> </tr> </tbody> </table>	Bit					Description	4	3	2	1	0	1	X	X	X	X	Disable <i>setup changed P2</i> trip												
	Bit					Description																								
4	3	2	1	0																										
1	X	X	X	X	Disable <i>setup changed P2</i> trip																									

<b>Absolute EnDat communication only or BiSS* encoder</b>																								
<b>Device Type (2x.038)</b>	EnDat (4) for an EnDat communications only encoder BiSS* (6) for a BiSS communication only encoder																							
<b>Auto-configuration Select (2x.041)</b>	Auto-configuration is enabled as default and automatically sets up the following parameters: Rotary Turns Bits ( <b>2x.033</b> ) (Not BiSS*) Rotary Lines Per Revolution ( <b>2x.034</b> ) (Not BiSS*) Comms Bits ( <b>2x.035</b> ) (Not BiSS*) Comms Baud Rate ( <b>2x.037</b> ) (BiSS* Only) Recovery Time ( <b>2x.060</b> ) = 13 $\mu$ s (BiSS* only) Calculation Time ( <b>2x.061</b> ) = 5 $\mu$ s (BiSS* only) These parameters can be entered manually when Pr <b>2x.041</b> is set to Disabled (0).																							
<b>Comms Baud Rate (2x.037)</b>	100 k (0), 200 k (1), 300 k (2), 400 k (3), 500 k (4), 1 M (5), 1.5 M (6), 2 M (7), 4 M (8)																							
<b>Error Detection Level (2x.040)</b>	<table border="1"> <thead> <tr> <th colspan="5">Bit</th> <th rowspan="2">Description</th> </tr> <tr> <th>4</th> <th>3</th> <th>2</th> <th>1</th> <th>0</th> </tr> </thead> <tbody> <tr> <td>X</td> <td>1</td> <td>X</td> <td>X</td> <td>X</td> <td>Disable trips <i>Comms timeout P2</i> to <i>SSI Error P2</i></td> </tr> <tr> <td>1</td> <td>X</td> <td>X</td> <td>X</td> <td>X</td> <td>Disable <i>setup changed P2</i> trip</td> </tr> </tbody> </table>	Bit					Description	4	3	2	1	0	X	1	X	X	X	Disable trips <i>Comms timeout P2</i> to <i>SSI Error P2</i>	1	X	X	X	X	Disable <i>setup changed P2</i> trip
	Bit					Description																		
	4	3	2	1	0																			
X	1	X	X	X	Disable trips <i>Comms timeout P2</i> to <i>SSI Error P2</i>																			
1	X	X	X	X	Disable <i>setup changed P2</i> trip																			

\* BiSS is not currently supported.

Absolute SSI communications only encoder																														
<b>Device Type (2x.038)</b>	SSI (5) for an SSI communications only encoder																													
<b>SSI Binary Mode (2x.048)</b>	Off (0) = Gray Code On (1) = Binary Mode																													
<b>Rotary Turns Bits (2x.033)</b>	Set to the number of turns bits for the encoder (this is usually 12 bits for a multi-turn SSI encoder)																													
<b>Comms Bits (2x.035)</b>	Total number of bits of position information for the encoder (this is usually 25 bits for a multi-turn SSI encoder)																													
<b>Comms Baud Rate (2x.037)</b>	100 k (0), 200 k (1), 300 k (2), 400 k (3), 500 k (4), 1 M (5), 1.5 M (6), 2 M (7), 4 M (8)																													
<b>Error Detection Level (2x.040)</b>	<table border="1"> <thead> <tr> <th colspan="5">Bit</th> <th rowspan="2">Description</th> </tr> <tr> <th>4</th> <th>3</th> <th>2</th> <th>1</th> <th>0</th> </tr> </thead> <tbody> <tr> <td>X</td> <td>X</td> <td>1</td> <td>X</td> <td>X</td> <td>Enable SSI power supply alarm bit monitor</td> </tr> <tr> <td>X</td> <td>1</td> <td>X</td> <td>X</td> <td>X</td> <td>Disable trips <i>Comms timeout P2</i> to <i>SSI Error P2</i></td> </tr> <tr> <td>1</td> <td>X</td> <td>X</td> <td>X</td> <td>X</td> <td>Disable <i>Setup Changed P2</i> trip</td> </tr> </tbody> </table>	Bit					Description	4	3	2	1	0	X	X	1	X	X	Enable SSI power supply alarm bit monitor	X	1	X	X	X	Disable trips <i>Comms timeout P2</i> to <i>SSI Error P2</i>	1	X	X	X	X	Disable <i>Setup Changed P2</i> trip
	Bit					Description																								
	4	3	2	1	0																									
	X	X	1	X	X	Enable SSI power supply alarm bit monitor																								
X	1	X	X	X	Disable trips <i>Comms timeout P2</i> to <i>SSI Error P2</i>																									
1	X	X	X	X	Disable <i>Setup Changed P2</i> trip																									

### 6.3 Encoder Simulation Output Set-up

The drive supports three modes of encoder simulation output.

- Hardware mode - Incremental signals (AB, FD)
- Software mode - Incremental signals (AB, FD, FR)
- Software mode - Absolute SSI data

The availability of the encoder simulation output is dependent on the type of feedback device connected to the P1 position interface. Table 5-3 *Availability of the P2 position feedback interface and the encoder simulation output* on page 27 for more information on the availability of the encoder simulation output. The status of the encoder simulation output can be seen in Encoder Simulation Status (**1x.086**) as follows:

None (0)	The encoder simulation output is not enabled or is not available
Full (1)	Full encoder simulation with marker output is available
No Marker (2)	Encoder simulation without marker output is available

#### 6.3.1 Hardware mode - Incremental signals (AB, FD)

The hardware mode provides incremental signals derived via hardware from the P1 position feedback interface on the module/drive with negligible delay. The supported incremental output signals are AB and FD. Hardware mode only produces an output when the input device connected to the P1 position interface is AB, FD, FR, SC, SC Hiperface, SC EnDat or SC SSI type devices. It should be noted that with a SINCOS source device, the output is based on the zero crossings of the sine wave inputs and does not include interpolation.

<b>Hardware mode set-up example (SI-Universal Encoder P1 interface as the source)</b>	
<i>Encoder Simulation Source (1x.085)</i>	This parameter must be set to Pr <b>1x.029</b> to select the P1 position interface of the option module as the source.
<i>Encoder Simulation Mode (1x.088)</i>	Set to a value of Hardware (0)
<i>Encoder Simulation Hardware Divider (1x.089)</i>	This parameter defines the divider ratio between the device connected to the P1 position feedback interface and the output. <b>0</b> = 1/1, <b>1</b> = 1/2, <b>2</b> = 1/4, <b>3</b> = 1/8, <b>4</b> = 1/16, <b>5</b> = 1/32, <b>6</b> = 1/64, <b>7</b> = 1/128
<i>Encoder Simulation Hardware Marker Lock (1x.090)</i>	<b>0</b> = The marker output is derived directly from the marker input <b>1</b> = The incremental output signals are adjusted on each marker event so that the A and B are high with an AB type output, or F is high with an FD type output.
<i>Encoder SimulationOutputMode (1x.098)</i>	<b>AB/Gray</b> (0) for a AB quadrature output signals <b>FD/Binary</b> (1) for Frequency and Direction output signals

<b>Hardware mode set-up example (Drive P1 interface as the source, marker direct with FD output)</b>	
<i>Encoder Simulation Source (1x.085)</i>	Set Pr <b>1x.085</b> to Pr <b>03.029</b> to select the P1 interface on the drive as the source.
<i>Encoder Simulation Mode (1x.088)</i>	Set to a value of Hardware (0)
<i>Encoder Simulation Hardware Divider (1x.089)</i>	Scaling is not available in this configuration, Pr <b>1x.089</b> should be set to 0.
<i>Encoder Simulation Hardware Marker Lock (1x.090)</i>	Encoder simulation hardware marker lock is not available in this configuration.
<i>Encoder SimulationOutputMode (1x.098)</i>	This parameter has no effect in this configuration, the output signal type will match in the input signal type.

### 6.3.2 Software mode - Incremental signals (AB, FD, or FR)

In software mode, the encoder simulation output is derived via software from the selected source with a minimum delay of 250 µs which may be extended with *Encoder Simulation Sample Period* (1x.087). For incremental output signals, the resolution of the output can be defined by either selecting the required output lines per revolution or by an output ratio.

#### Lines per revolution

The output resolution of the encoder simulation output is defined by *Encoder Simulation Output Lines Per Revolution* (1x.092).

AB quadrature output signals, software mode setup – Lines per revolution	
<i>Encoder Simulation Source</i> (1x.085)	Set to the parameter number of the position source Pr <b>1x.029</b> to use the P1 position interface as the source. Pr <b>03.029</b> to select the P1 interface on the drive as the source. This parameter can be set to any other valid position reference generated by the drive or an option module.
<i>Encoder Simulation Mode</i> (1x.088)	Set to a value of <b>Lines Per Rev (1)</b>
<i>Encoder Simulation Output Lines Per Revolution</i> (1x.092)	Set to the required output lines per revolution. The maximum output lines per revolution are 16384.
<i>Encoder Simulation Output Mode</i> (1x.098)	<b>AB/Gray</b> (0) for a AB quadrature output signals

Frequency and Direction or Forward and Reverse output signals, software mode setup – Lines per revolution	
<i>Encoder Simulation Source</i> (1x.085)	Set to the parameter number of the position source Pr <b>1x.029</b> to use the P1 position interface as the source. Pr <b>2x.029</b> to use the P2 position interface as the source. This parameter can be set to any other valid position reference generated by the drive or an option module.
<i>Encoder Simulation Mode</i> (1x.088)	Set to a value of <b>Lines Per Rev (1)</b>
<i>Encoder Simulation Output Lines Per Revolution</i> (1x.092)	Set to the required equivalent output lines per revolution.
<i>Encoder Simulation Output Mode</i> (1x.098)	<b>AB/Grey</b> (0) for AB quadrature output signals <b>FD/Binary</b> (1) for Frequency and Direction output signals <b>FR/Binary</b> (2) for Forward and Reverse output signals

#### Ratio

In ratio mode the resolution of the input source is based on a 16 bit position feedback device (i.e. equivalent to an AB quadrature encoder with a resolution of 16384 lines per revolution). The output resolution of the encoder simulation output is defined by the ratio of *Encoder Simulation Numerator* (1x.093) and *Encoder Simulation Denominator* (1x.094).

**AB quadrature output signals, software mode setup – Ratio, Frequency and Direction or Forward and Reverse output signals, software mode setup-ratio**

<i>Encoder Simulation Source (1x.085)</i>	Set to the parameter number of the position source Pr <b>1x.029</b> to use the P1 position interface on the drive as the source. Pr <b>2x.029</b> to use the P2 position interface on the drive as the source. This parameter can be set to any other valid position reference generated by the drive or an option module.
<i>Encoder Simulation Mode (1x.088)</i>	Set to a value of Ratio (2)
<i>Encoder Simulation Numerator (1x.093) and Encoder Simulation Denominator (1x.094)</i>	Set these two parameters to give the required output ratio.
<i>Encoder Simulation Output Mode (1x.098)</i>	<b>AB/Gray</b> (0) for a AB quadrature output signals <b>FD/Binary</b> (1) for Frequency and Direction output signals <b>FR/Binary</b> (2) for Forward and Reverse output signals

**Software mode - Absolute SSI data**

In software mode, the encoder simulation output is derived via software from the selected source with a minimum delay of 250 µs which may be extended with *Encoder Simulation Sample Period (1x.087)*. In SSI output mode drive will simulate an SSI encoder, where the number of bits and the format of the position message can be adjusted.

**Absolute SSI data, software mode setup**

<i>Encoder Simulation Source (1x.085)</i>	Set to the parameter number of the position source. Pr <b>1x.029</b> to use the P1 position interface on the drive as the source. Pr <b>2x.029</b> to use the P2 position interface on the drive as the source. This parameter can be set to any other valid position reference generated by the drive or an option module.
<i>Encoder Simulation Mode (1x.088)</i>	Set to a value of SSI (3)
<i>Encoder Simulation SSI Turns Bits (1x.096)</i>	Set to the number of bits representing the number of turns in the position message.
<i>Encoder Simulation SSI Comms Bits (1x.097)</i>	Set to the number bits in the whole position message.
<i>Encoder Simulation Output Mode (1x.098)</i>	<b>AB/Gray</b> (0) for position data in Gray code format <b>FD/Binary</b> (1) or <b>FR/Binary</b> (2) for position data in binary format.

## 6.4 Freeze System

The module has two freeze functions that can capture the position from either the P1 or P2 position interface on the module when a freeze trigger event occurs. A common freeze logic system is also provided, so that the freeze trigger events can be combined either to trigger the freeze system in the drive or on another option module.

## 6.5 Thermistor input

The SI-Universal Encoder module has a thermistor input which allows connection of a motor thermistor.

Thermistor input setup									
<i>P1 Thermistor Type (1x.118)</i>	<p>This parameter defines the operating mode of the P1 Thermistor input.</p> <table border="1"> <thead> <tr> <th>Value</th> <th>Text</th> </tr> </thead> <tbody> <tr> <td>0</td> <td>DIN44082</td> </tr> <tr> <td>1</td> <td>KTY84</td> </tr> <tr> <td>2</td> <td>0.8mA</td> </tr> </tbody> </table>	Value	Text	0	DIN44082	1	KTY84	2	0.8mA
Value	Text								
0	DIN44082								
1	KTY84								
2	0.8mA								
<i>P1 Thermistor Feedback (1x.119)</i>	This parameter displays the resistance of the thermistor on the P1 interface.								
<i>P1 Thermistor Trip Threshold (1x.120)</i>	Set this parameter to define the thermistor trip threshold for the P1 interface.								
<i>P1 Thermistor Reset Threshold (1x.121)</i>	Set this parameter to define the thermistor reset threshold for the P1 interface.								
<i>P1 Thermistor Temperature (1x.122)</i>	This read-only parameter displays the temperature of the device based on the resistance to temperature characteristic for the specified device.								
<i>P1 Thermistor Fault Detection (1x.123)</i>	<p>This parameter defines the fault detection for the P1 thermistor input.</p> <table border="1"> <thead> <tr> <th>Value</th> <th>Text</th> </tr> </thead> <tbody> <tr> <td>0</td> <td>None</td> </tr> <tr> <td>1</td> <td>Temperature</td> </tr> <tr> <td>2</td> <td>Temp or Short</td> </tr> </tbody> </table>	Value	Text	0	None	1	Temperature	2	Temp or Short
Value	Text								
0	None								
1	Temperature								
2	Temp or Short								

How to use this guide
Safety information
Introduction
Mechanical Installation
Electrical Installation
<b>Getting started</b>
Parameters
Advanced operation
Diagnostics
Terminal data
Index

# 7 Parameters

## 7.1 Introduction

The parameters listed in this chapter are used for programming and monitoring the SI-Universal Encoder option module.

### NOTE

The same parameter structure is available in menu 15, 16 and 17 referring to slots 1, 2 and 3 for P1 interface and menu 25, 26 and 27 referring to slots 1, 2 and 3 for P2 interface.

Functions	Slot 1	Slot 2	Slot 3
P1 position interface, freeze system, encoder simulation output and temperature sensor input	Menu 15	Menu 16	Menu 17
P2 position interface	Menu 25	Menu 26	Menu 27



Before attempting to adjust any parameters, refer to section 2 *Safety information* on page 7

**Table 7-1 Key to parameter coding**

Coding	Attribute
RW	Read/write: can be written by the user.
RO	Read only: can only be read by the user.
Bit	1 bit parameter.
Bin	Binary parameter.
Txt	Text: the parameter uses text strings instead of numbers.
FI	Filtered: some parameters which can have rapidly changing values are filtered when displayed on the drive keypad for easy viewing.
DE	Destination: indicates that this parameter can be a destination parameter.
RA	Rating dependant: this parameter is likely to have different values and ranges with drives of different voltage and current ratings. These parameters are not transferred by smart cards when the rating of the destination drive is different from the source drive.
NC	Not cloned: not transferred to or from smart cards during cloning.
PT	Protected: cannot be used as a destination.
US	User save: saved in drive EEPROM when the user initiates a parameter. save.
PS	Power-down save: automatically saved in drive EEPROM at power-down.
Date	Date Parameter.
Time	Time Parameter.
Chr	Character Parameter.
IP	IP Address.
MAC	MAC Address.
Ver	Version Number.
SMP	Slot, menu, parameter.
Num	Number Parameter.
ND	No default value.



## 7.2 Menu 1x parameter for P1 Interface

### 7.2.1 Menu 1x single line parameter descriptions

Parameter	Range(⚡)	Default(⇄)	Type						
			RO	Num	ND	NC	PT		
<b>1x.001</b>	Module ID	0 to 65535		RO	Num	ND	NC	PT	
<b>1x.002</b>	Software Version	00.00.00.00 to 99.99.99.99		RO	Num	ND	NC	PT	
<b>1x.003</b>	Hardware Version	0.00 to 99.99		RO	Num	ND	NC	PT	
<b>1x.004</b>	Serial Number LS	0 to 99999999		RO	Num	ND	NC	PT	
<b>1x.005</b>	Serial Number MS	0 to 99999999		RO	Num	ND	NC	PT	
<b>1x.006</b>	Module Status	Bootldr-update (-2), Bootldr-idle (-1), Initialising (0), OK (1), Config (2), Error (3)		RO	Txt	ND	NC	PT	
<b>1x.007</b>	Module Reset	Off (0) or On (1)	Off (0)	RW	Bit		NC		
<b>1x.024</b>	Module Temperature	-128 to 127 °C		RO	Num	ND	NC	PT	
<b>1x.025</b>	Slot Indicator	0 to 8		RO	Num	ND	NC	PT	
<b>1x.026</b>	Slot Menu Number	0 to 255		RO	Num	ND	NC	PT	
<b>1x.027</b>	P1 Speed Feedback	-214748364.8 to 214748364.7 rpm		RO	Num	ND	NC	PT	FI
<b>1x.028</b>	P1 Revolution/Pole Pitch Counter	0 to 65535		RO	Num	ND	NC	PT	
<b>1x.029</b>	P1 Position	0 to 65535		RO	Num	ND	NC	PT	
<b>1x.030</b>	P1 Fine Position	0 to 65535		RO	Num	ND	NC	PT	
<b>1x.031</b>	P1 Marker Mode	0000 to 1111	0100	RW	Bin				US
<b>1x.032</b>	P1 Marker Flag	Off (0) or On (1)	Off (0)	RW	Bit		NC		
<b>1x.033</b>	P1 Rotary Turns Bits	0 to 16	16	RW	Num				US
<b>1x.034</b>	P1 Rotary Lines Per Revolution	1 to 100000	4096	RW	Num				US
<b>1x.035</b>	P1 Comms Bits	0 to 48	0	RW	Num				US
<b>1x.036</b>	P1 Supply Voltage	5 V (0), 8 V (1), 15 V (2), Disabled (3)	5 V (0)	RW	Txt				US
<b>1x.037</b>	P1 Comms Baud Rate	100 k (0), 200 k (1), 300 k (2), 400 k (3), 500 k (4), 1 M (5), 1.5 M (6), 2 M (7), 4 M (8) Baud	300 k (2) Baud	RW	Txt				US
<b>1x.038</b>	P1 Device Type	AB (0), FD (1), FR (2), AB Servo (3), FD Servo (4), FR Servo (5), SC (6), SC Hiperface (7), EnDat (8), SC EnDat (9), SSI (10), SC SSI (11), SC Servo (12), BiSS* (13), Drive P1 (14), Reserved (15), Reserved (16), SC BiSS* (17)	AB Servo (3)	RW	Txt				US
<b>1x.039</b>	P1 Termination Select	0 to 2	1	RW	Num				US
<b>1x.040</b>	P1 Error Detection Level	00000 to 11111	00001	RW	Bin				US
<b>1x.041</b>	P1 Auto- configuration Select	Disabled (0), Enabled (1)	Enabled (1)	RW	Txt				US
<b>1x.042</b>	P1 Feedback Filter	Disabled (0), 1 ms (1), 2 ms (2), 4 ms (3), 8 ms (4), 16 ms (5)	Disabled (0)	RW	Txt				US

How to use this guide
Safety information
Introduction
Mechanical Installation
Electrical Installation
Getting started
<b>Parameters</b>
Advanced operation
Diagnostics
Terminal data
Index

Parameter		Range(⊘)	Default(⇒)	Type					
1x.043	P1 Maximum Reference	0 to 50000	3000	RW	Num				US
1x.044	P1 Reference Scaling	0.000 to 4.000	1.000	RW	Num				US
1x.045	P1 Reference	±100.0 %		RO	Num	ND	NC	PT	FI
1x.046	P1 Reference destination	0.000 to 59.999	0.000	RW	Num	DE		PT	US
1x.047	P1 SSI Incremental Mode	Off (0) or On (1)	Off (0)	RW	Bit				US
1x.048	P1 SSI Binary Mode	Off (0) or On (1)	Off (0)	RW	Bit				US
1x.049	P1 Additional Power-up Delay	0.0 to 25.0 s	0.0 s	RW	Num				US
1x.050	P1 Feedback Lock	Off (0) or On (1)	Off (0)	RW	Bit				US
1x.051	P1 Linear Feedback Select	Off (0) or On (1)	Off (0)	RW	Bit				US
1x.052	P1 Linear Comms Pitch	0.001 to 100.000	0.001	RW	Num				US
1x.053	P1 Linear Line Pitch	0.001 to 100.000	0.001	RW	Num				US
1x.054	P1 Linear Comms And Line Pitch Units	millimetres (0), micrometres (1)	millimetres (0)	RW	Txt				US
1x.055	P1 Pole Pitch	0.01 to 1000.00 mm	10.00 mm	RW	Num				US
1x.056	P1 Feedback Reverse	Off (0) or On (1)	Off (0)	RW	Bit				US
1x.057	P1 Normaliation Turns	0 to 16	16	RW	Num				US
1x.058	P1 Normalised Position	-2147483648 to 2147483647		RO	Num	ND	NC	PT	
1x.059	P1 Normalised Marker Position	-2147483648 to 2147483647		RO	Num	ND	NC	PT	
1x.060	P1 Calculation Time	0 to 20 µs	5 µs	RW	Num				US
1x.061	P1 Recovery Time	5 to 100 µs	30 µs	RW	Num				US
1x.062	P1 Line Delay Time	0 to 5000 ns	0 ns	RO	Num		NC	PT	US
1x.063	P1 Low Speed Update Rate Active	Off (0) or On (1)		RO	Bit	ND	NC	PT	
1x.064	P1 Encoder Protocol Detected	None (0), Hiperface (1), EnDat2.1 (2), EnDat2.2 (3), BiSS* (4)		RO	Txt	ND	NC	PT	
1x.067	P1 User Comms Enable	0 to 1	0	RW	Num		NC	PT	
1x.068	P1 User Comms Transmit Register	0 to 65535	0	RW	Num		NC	PT	
1x.069	P1 User Comms Receive Register	0 to 65535	0	RW	Num		NC	PT	
1x.070	P1 Position Feedback Signals	000000 to 111111		RO	Bin	ND	NC	PT	
1x.071	P1 Error Detected	Off (0) or On (1)		RO	Bit	ND	NC	PT	
1x.075	Initialise Position Feedback	Off (0) or On (1)	Off (0)	RW	Bit		NC		
1x.076	Position Feedback Initialized	0000000000 to 1111111111	0000000000 0	RO	Bin		NC	PT	
1x.085	Encoder Simulation Source	0.000 to 59.999	0.000	RW	Num			PT	US

Parameter		Range(⇩)	Default(⇨)	Type					
1x.086	Encoder Simulation Status	None (0), Full (1), No Marker Pulse (2)		RO	Txt	ND	NC	PT	
1x.087	Encoder Simulation Sample Period	0.25 (0), 1 (1), 4 (2), 16 (3) ms	0.25 (0) ms	RW	Txt				US
1x.088	Encoder Simulation Mode	Hardware (0), Lines Per Rev (1), Ratio (2), SSI (3)	Hardware (0)	RW	Txt				US
1x.089	Encoder Simulation Hardware Divider	0 to 7	0	RW	Num				US
1x.090	Encoder Simulation Hardware Marker Lock	Off (0) or On (1)	Off (0)	RW	Bit				US
1x.091	Encoder Simulation Incremental Mode Select	Off (0) or On (1)	Off (0)	RW	Bit				US
1x.092	Encoder Simulation Output Lines Per Revolution	1 to 16384	4096	RW	Num				US
1x.093	Encoder Simulation Numerator	1 to 65536	65536	RW	Num				US
1x.094	Encoder Simulation Denominator	1 to 65536	65536	RW	Num				US
1x.095	Encoder Simulation Output Roll-over Limit	1 to 65535	65535	RW	Num				US
1x.096	Encoder Simulation SSI Turns Bits	0 to 16	16	RW	Num				US
1x.097	Encoder Simulation SSI Comms Bits	2 to 48	33	RW	Num				US
1x.098	Encoder Simulation Output Mode	AB/Gray (0), FD/Binary (1), FR/Binary (2)	AB/Gray (0)	RW	Txt				US
1x.100	F1 Freeze Trigger Source	24V Freeze Input (1), P1 Marker (2), P2 Marker (3), Common (4)	24V Freeze Input (1)	RW	Txt				US
1x.101	F1 Freeze Mode	Rising 1st (0), Falling 1st (1), Rising all (2), Falling all (3)	Rising 1st (0)	RW	Txt				US
1x.102	F1 Freeze Position Source	P1 (0), P2 (1)	P1 (0)	RW	Txt				US
1x.103	F1 Normalised Freeze Position	-2147483648 to 2147483647		RO	Num	ND	NC	PT	
1x.104	F1 Freeze Flag	Off (0) or On (1)		RW	Bit	ND	NC	PT	
1x.105	F2 Freeze Trigger Source	24V Freeze Input (1), P1 Marker (2), P2 Marker (3), Common (4)	24V Freeze Input (1)	RW	Txt				US
1x.106	F2 Freeze Mode	Rising 1st (0), Falling 1st (1), Rising all (2), Falling all (3)	Rising 1st (0)	RW	Txt				US
1x.107	F2 Freeze Position Source	P1 (0), P2 (1)	P1 (0)	RW	Txt				US
1x.108	F2 Normalised Freeze Position	-2147483648 to 2147483647		RO	Num	ND	NC	PT	
1x.109	F2 Freeze Flag	Off (0) or On (1)		RW	Bit	ND	NC	PT	
1x.110	Common Freeze Source 1	24V Freeze Input (1), P1 Marker (2), P2 Marker (3), Disabled (4)	24V Freeze Input (1)	RW	Txt				US

How to use this guide
Safety Information
Introduction
Mechanical Installation
Electrical Installation
Getting started
<b>Parameters</b>
Advanced operation
Diagnostics
Terminal data
Index

Parameter		Range(⚡)	Default(⇌)	Type						
1x.111	Common Freeze Source 2	24V Freeze Input (1), P1 Marker (2), P2 Marker (3), Disabled (4)	24V Freeze Input (1)	RW	Txt					US
1x.112	Common Freeze Mode	0000 to 1111	0	RW	Bin					US
1x.113	Freeze Input States	00 to 11		RO	Bin	ND	NC	PT		
1x.118	P1 Thermistor Type	DIN44082 (0), KTY84 (1), 0.8mA (2)	DIN44082 (0)	RW	Txt					US
1x.119	P1 Thermistor Feedback	0 to 10000 Ω		RO	Num	ND	NC	PT		
1x.120	P1 Thermistor Trip Threshold	0 to 10000 Ω	3300 Ω	RW	Num					US
1x.121	P1 Thermistor Reset Threshold	0 to 10000 Ω	1800 Ω	RW	Num					US
1x.122	P1 Thermistor Temperature	-50 to 300 °C		RO	Num	ND	NC	PT		
1x.123	P1 Thermistor Fault Detection	None (0), Temperature (1), Temp or Short (2)	None (0)	RW	Txt					US

RW	Read / Write	RO	Read-only	Bit	Bit parameter	Txt	Text string	Date	Date parameter	Time	Time parameter
Chr	Character parameter	Bin	Binary parameter	IP	IP address	Mac	MAC address	Ver	Version number	SMP	Slot, menu, parameter
Num	Number parameter	DE	Destination	ND	No default value	RA	Rating dependent	NC	Non-copyable	PT	Protected
FI	Filtered	US	User save	PS	Power-down save						

\* BiSS is not currently supported.

## 7.2.2 P1 interface logic diagram

Figure 7-1 P1 Position feedback interface

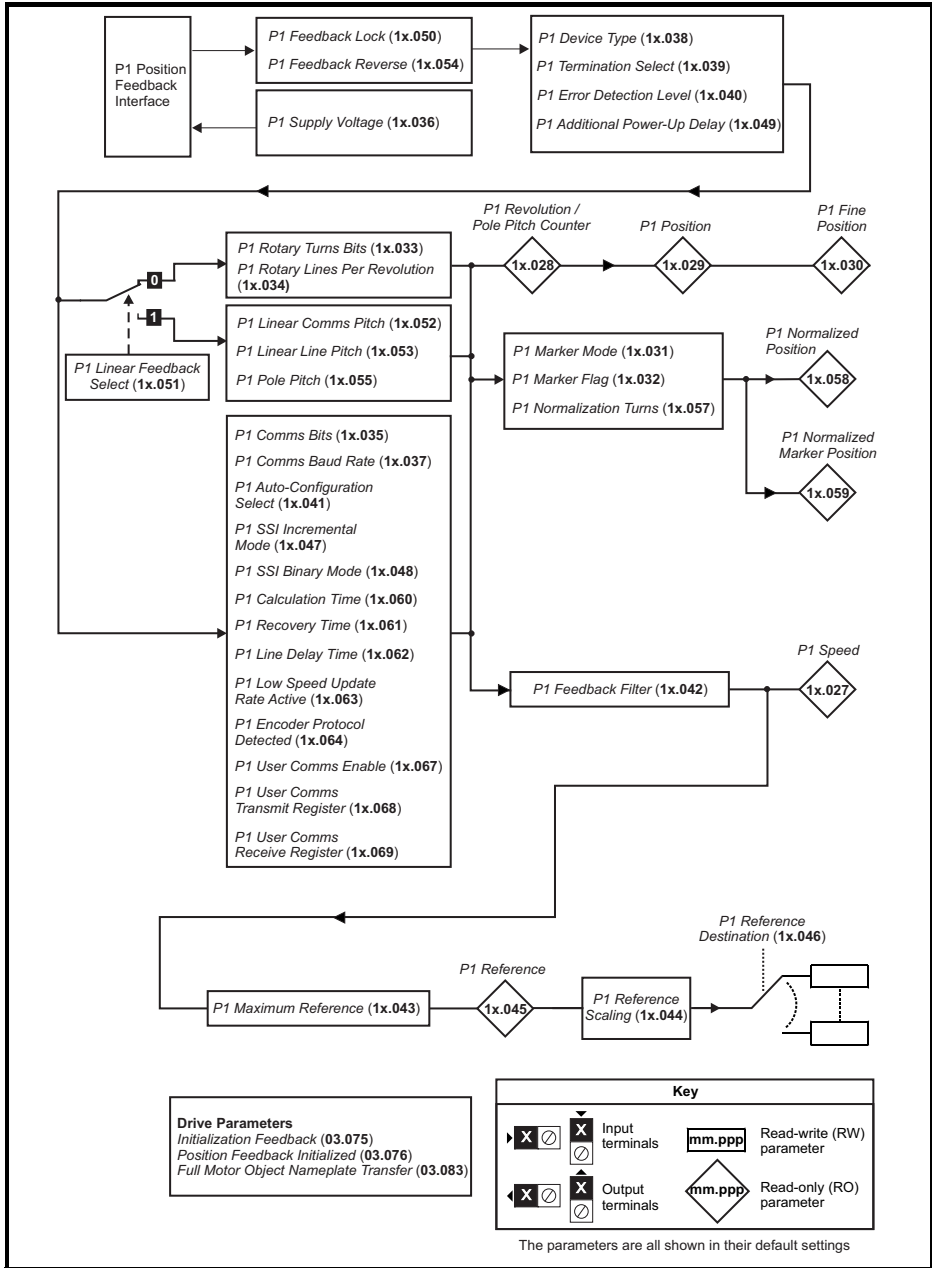

**Figure 7-2 P1 Encoder Simulation Output**

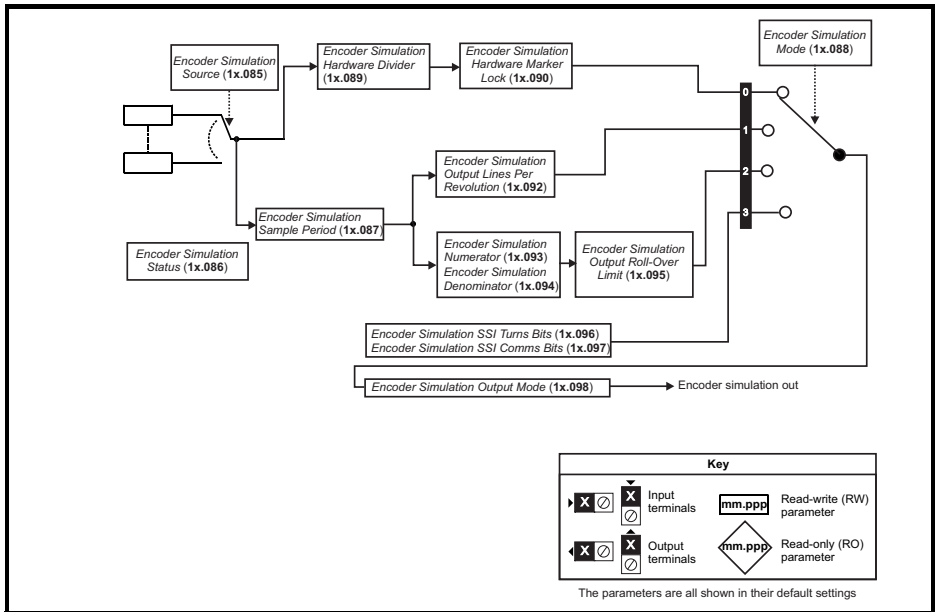

**Figure 7-3 P1 Freeze System**

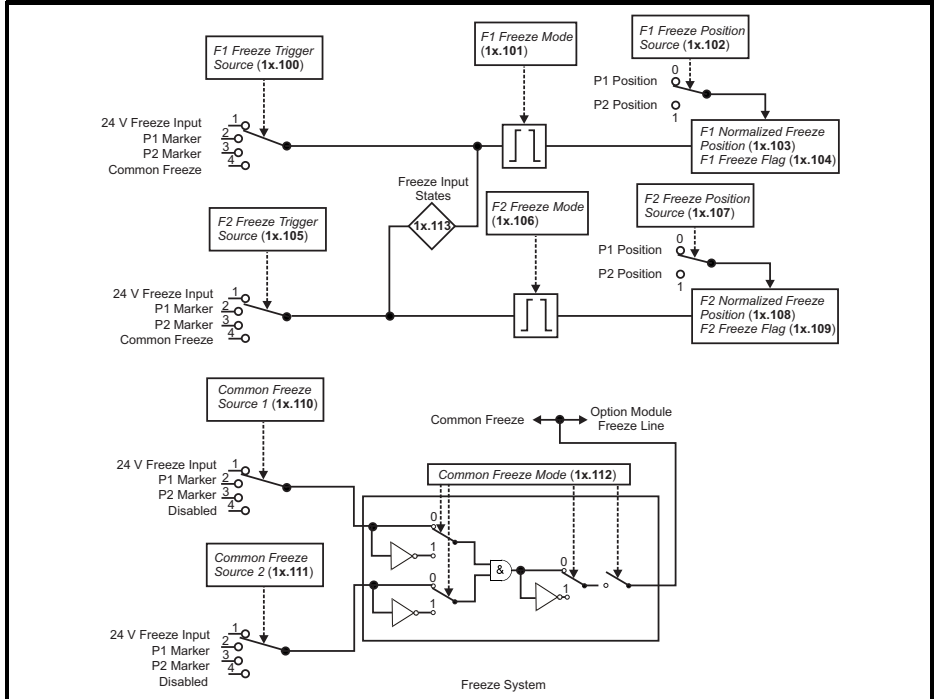

**Figure 7-4 P1 Position feedback interface thermistor input**

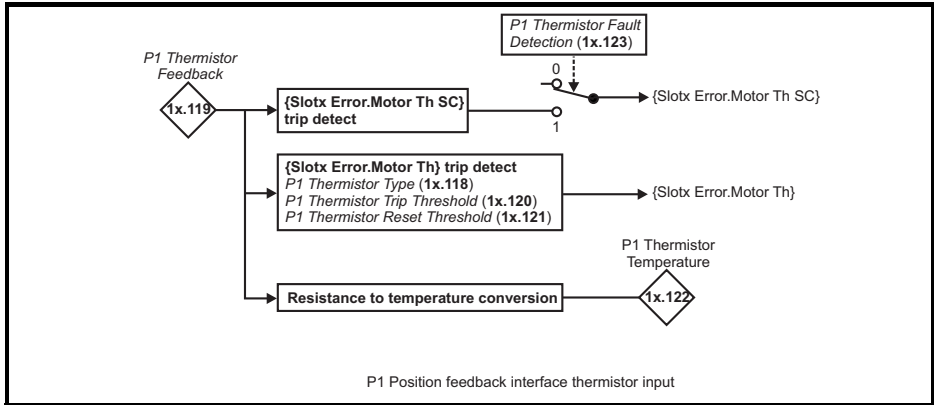

**7.2.3 Menu 1x P1 Interface parameter descriptions**

1x.001		Module ID	
Minimum	0	Maximum	65535
Default		Units	
Type	16 Bit Volatile	Update Rate	Power-up write
Display Format	None	Decimal Places	0
Coding	RO, ND, NC, PT, BU		

This parameter shows the module ID code. The module ID for the SI-Universal Encoder module is **106**.

1x.002		Software Version	
Minimum	0 (Display: 00.00.00.00)	Maximum	999999 (Display: 99.99.99.99)
Default		Units	
Type	32 Bit Volatile	Update Rate	Power-up write
Display Format	Version Number	Decimal Places	0
Coding	RO, ND, NC, PT		

Module firmware version in ww.xx.yy.zz format.

1x.003		Hardware Version	
Minimum	0.00	Maximum	99.99
Default		Units	
Type	16 Bit Volatile	Update Rate	Power-up write
Display Format	None	Decimal Places	2
Coding	RO, ND, NC, PT		

Contains the module's hardware version information in the format xx.yy.

<b>1x.004</b>		<b>Serial Number LS</b>	
Minimum	0	Maximum	99999999
Default		Units	
Type	32 Bit Volatile	Update Rate	Power-up write
Display Format	None	Decimal Places	0
Coding	RO, ND, NC, PT		

The module serial number is available as a pair of 32 bit values where *Serial Number LS (1x.004)* provides the least significant 8 decimal digits and *Serial Number MS (1x.005)* provides the most significant 8 decimal digits. The reconstructed serial number is  $((\mathbf{MM.005} * 10000000) + \mathbf{MM.004})$ . For example serial number "0001234567898765" would be stored as  $\mathbf{1x.005} = 12345$ ,  $\mathbf{1x.004} = 67898765$ .

<b>1x.005</b>		<b>Serial Number MS</b>	
Minimum	0	Maximum	99999999
Default		Units	
Type	32 Bit Volatile	Update Rate	Power-up write
Display Format	None	Decimal Places	0
Coding	RO, ND, NC, PT		

See *Serial Number LS (1x.004)*.

<b>1x.006</b>		<b>Module Status</b>	
Minimum	-2	Maximum	3
Default		Units	
Type	8 Bit Volatile	Update Rate	Background write
Display Format	None	Decimal Places	0
Coding	RO, Txt, ND, NC, PT		

<b>Value</b>	<b>Text</b>	<b>Description</b>
-2	Bootldr-update	The bootloader is updating the application image
-1	Bootldr-idle	The bootloader is idle
0	Initializing	The module is initializing
1	OK	Module is initialized with no errors present
2	Config	A configuration error has been detected
3	Error	An error has occurred preventing the module from running correctly

This parameter shows the status of the module.



<b>1x.007</b>		<b>Module Reset</b>	
Minimum	0	Maximum	1
Default	0	Units	
Type	1 Bit Volatile	Update Rate	Read every 200 ms. Written to 0 on module initialization
Display Format	None	Decimal Places	0
Coding	RW, NC		

When set, the module performs a warm reset. When the reset has been performed and the module is performing its initialization routines, the parameter will be cleared to zero.

**NOTE**

The drive, and any other modules installed on the drive will not be affected by the reset.

<b>1x.024</b>		<b>Module Temperature</b>	
Minimum	-128	Maximum	127
Default		Units	°C
Type	16 Bit Volatile	Update Rate	Background write
Display Format	None	Decimal Places	0
Coding	RO, ND, NC, PT		

Shows the internal temperature of the module

<b>1x.025</b>		<b>Slot Indicator</b>	
Minimum	0	Maximum	8
Default		Units	
Type	8 Bit Volatile	Update Rate	Power-up write
Display Format	None	Decimal Places	0
Coding	RO, ND, NC, PT		

Indicates which slot number the module is installed in.

<b>1x.026</b>		<b>Slot Menu Number</b>	
Minimum	0	Maximum	255
Default		Units	
Type	8 Bit Volatile	Update Rate	Power-up write
Display Format	None	Decimal Places	0
Coding	RO, ND, NC, PT, BU		

Indicates the menu number of the main set-up menu for the module.

<b>1x.027</b>		<b>P1 Speed Feedback</b>	
Minimum	-214748364.8	Maximum	214748364.7
Default		Units	rpm
Type	32 Bit Volatile	Update Rate	4 ms write
Display Format	None	Decimal Places	1
Coding	RO, FI, ND, NC, PT		

Provided the set-up parameters for the position feedback device connected to the drive P1 position interface are correct, *P1 Speed Feedback (1x.027)* shows the speed derived from the feedback. The speed is given in mm/s if *P1 Linear Feedback Select (1x.051)* = 1 and *Linear Speed Select (1x.055)* on the drive = 1, otherwise it is given in rpm. The value shown is measured over a 16 ms sliding window period.

<b>1x.028</b>		<b>P1 Revolution/Pole Pitch Counter</b>	
Minimum	0	Maximum	65535
Default		Units	
Type	16 Bit Volatile	Update Rate	4 ms write
Display Format	None	Decimal Places	0
Coding	RO, ND, NC, PT, BU		

*P1 Revolution/Pole Pitch Counter (1x.028)*, *P1 Position (1x.029)* and *P1 Fine Position (1x.030)* combined, give the encoder position with a resolution of  $1/2^{32}$  of a revolution/pole pitch as a 48 bit number. If a rotary position feedback device is being used (*P1 Linear Feedback Select (1x.051)* = 0), then these quantities relate directly to the rotary position of the feedback device. If a linear feedback device is used, then one revolution or pole pitch relates to the distance given by *P1 Pole Pitch (1x.055)*.

47	32 31	16 15	0
Revolutions/Pole Pitches	Position	Fine Position	

Provided the position feedback interface set-up parameters are correct, the position is always converted to units of  $1/2^{32}$  of a revolution/pole pitch, but some parts of the value may not be relevant depending on the resolution of the feedback device. For example a 1024 line digital encoder produces 4096 counts per revolution, and so the position is represented by the bits in the shaded area only.

47	32 31	20 19	16 15	0
Revolutions/Pole Pitches	<b>Position</b>		Fine Position	

When the position feedback moves by more than one revolution or pole pitch, the *P1 Revolution/Pole Pitch Counter (1x.028)* increments or decrements in the form of a sixteen bit roll-over counter. If an absolute position feedback device (except AB Servo, FD Servo, FR Servo, SC Servo) is used, the position is initialized at power-up and each time the encoder is subsequently initialized with the absolute position including the revolution count if a multi-turn absolute rotary encoder is used, or the pole pitch count if an absolute linear encoder is used.

The position interface parameter descriptions cover rotary and linear applications, but the revolutions or pole pitches are always referred to as turns.

<b>1x.029</b>	<b>P1 Position</b>		
Minimum	0	Maximum	65535
Default		Units	
Type	16 Bit Volatile	Update Rate	4 ms write
Display Format	None	Decimal Places	0
Coding	RO, ND, NC, PT, BU		

See *P1 Revolution/Pole Pitch Counter (1x.028)*.

<b>1x.030</b>	<b>P1 Fine Position</b>		
Minimum	0	Maximum	65535
Default		Units	
Type	16 Bit Volatile	Update Rate	4 ms write
Display Format	None	Decimal Places	0
Coding	RO, ND, NC, PT, BU		

See *P1 Revolution/Pole Pitch Counter (1x.028)*.

<b>1x.031</b>	<b>P1 Marker Mode</b>		
Minimum	0 (Display: 0000)	Maximum	15 (Display: 1111)
Default	4 (Display: 0100)	Units	
Type	8 Bit User Save	Update Rate	Background read
Display Format	Binary	Decimal Places	0
Coding	RW		

**P1 Device Type (1x.038) : AB, FD, FR, AB Servo, FD Servo, FR Servo**

Each position feedback device produces incremental signals which are counted in hardware. If *P1 Marker Mode (1x.031) = 0* the following occurs when a marker event is produced by the Z1 input:

1. *P1 Position (1x.029)* and *P1 Fine Position (1x.030)* are reset to zero.
2. The bits in *P1 Normalized Position (1x.058)* related to *P1 Position (1x.029)* and *P1 Fine Position (1x.030)* are reset to zero
3. *P1 Marker Flag (1x.032)* is set to one.

The marker is a hardware function, and so the position appears as though it is reset at the marker event time even if this is between control system sample points. It should be noted that the marker event occurs on the rising edge of the marker pulse if the position change over the last sample was positive or on the falling edge if the position change over the last sample was negative. This ensures that the marker event occurs at the same physical location for either direction of rotation.

The action taken when a marker event occurs can be modified by setting the bits of *P1 Marker Mode (1x.031)* as described in the table below.

Bit	Effect of setting bit to one
0	No action is taken unless the marker flag is zero before the marker event occurs.
1	<i>P1 Revolution/Pole Pitch Counter (1x.028)</i> and the whole of <i>P1 Normalized Position (1x.058)</i> are also set to zero on a marker event.
2	<i>P1 Revolution/Pole Pitch Counter (1x.028)</i> , <i>P1 Position (1x.029)</i> , <i>P1 Fine Position (1x.030)</i> and the related part of <i>P1 Normalized Position (1x.058)</i> is transferred to <i>P1 Normalized Marker Position (1x.059)</i> and <i>P1 Marker Flag (1x.032)</i> is set to one.
3	If this bit is 0 the state of the marker is only undefined when the differential input is in the range from -200 mV to 200 mV. The marker pulse is only guaranteed to be recognized if it is at least 500 ns wide. This setting is used for most encoders with standard level marker pulses.  If this bit is set to 1 the undefined state region is reduced to the range from -30 mV to 30 mV. The marker pulse is only guaranteed to be recognized if it is at least 10 µs wide. The smaller undefined region is required for position feedback devices that produce a small marker pulse, such as the Heidenhain ERN1387 encoder. Note that the reduced undefined region is only provided for position feedback interface P1 and that this bit in <i>P2 Marker Mode (2x.031)</i> has no effect.

The marker input can be used for a standard type marker function or alternatively it can be used as an additional freeze input for the *P1 position feedback interface*.

***P1 Device Type (1x.038) : SC, SC Servo***

The marker function operates in the same way as for the digital incremental encoders. The resolution of the marker actions is only as accurate as the zero crossings of the sine waves.

***P1 Device Type (1x.038) : Any other device type***

The marker function cannot be used and *P1 Marker Mode (1x.031)* has no effect.

1x.032	P1 Marker Flag		
Minimum	0	Maximum	1
Default	0	Units	
Type	1 Bit Volatile	Update Rate	250 µs write
Display Format	None	Decimal Places	0
Coding	RW, NC		

*P1 Marker Flag (1x.032)* is set to one when a marker event occurs. The flag must be cleared by the user.

1x.033	P1 Rotary Turns Bit		
Minimum	0	Maximum	16
Default	16	Units	
Type	8 Bit User Save	Update Rate	Background read, auto-configuration write
Display Format	None	Decimal Places	0
Coding	RW		

*P1 Rotary Turns Bits (1x.033)* only has any effect if the position feedback interface is being used with a rotary device (i.e. *P1 Linear Feedback Select (1x.051)* = 0).

**P1 Device Type (1x.038) : SC Hiperface, SC EnDat, SC SSI, EnDat, BiSS\*, SC BiSS\*, SSI**

*P1 Rotary Turns Bits (1x.033)* is used to determine the number of bits within the comms messages from the position feedback device that represent turns. For a single turn encoder *P1 Rotary Turns Bits (1x.033)* must be set to zero. It should be noted that some SSI encoders include leading zeros before the turns information, and in this case the number of turns bits should include the leading zeros. The most significant bits in *P1 Revolution/Pole Pitch Counter (1x.028)* that are not included in the turns information provided by the encoder comms are held at zero. If *P1 Rotary Turns Bits (1x.033)* = 0 (single turn encoder) the whole of *P1 Revolution/Pole Pitch Counter (1x.028)* is held at zero. The number of bits of position information for a rotary device are calculated from *P1 Rotary Turns Bits (1x.033)* and *P1 Comms Bits (1x.035)*. If the resulting value is greater than 32 it is limited to 32. Some BiSS encoders include leading zeroes before the single turn position or the multi turn position, therefore *P1 Rotary Turns Bits (1x.033)* should include the number of leading zeroes. (See **1x.038**).

**P1 Device Type (1x.038) : Any other device type**

It is sometimes desirable to mask off the most significant bits of *P1 Revolution/Pole Pitch Counter (1x.028)*, but this does not have to be done for the drive to function correctly. If *P1 Rotary Turns Bits (1x.033)* = 0 the whole of *P1 Revolution/Pole Pitch Counter (1x.028)* is held at zero. If *P1 Rotary Turns Bits (1x.033)* has any other value it indicates the number of bits in *P1 Revolution/Pole Pitch Counter (1x.028)* that are not held at zero. For example, if *P1 Rotary Turns Bits (1x.033)* = 5, then *P1 Revolution/Pole Pitch Counter (1x.028)* counts up to 31 before being reset.

1x.034	P1 Rotary Lines Per Revolution		
Minimum	1	Maximum	100000
Default	4096	Units	
Type	32 Bit User Save	Update Rate	Background read, auto-configuration write
Display Format	None	Decimal Places	0
Coding	RW		

*P1 Rotary Lines Per Revolution (1x.034)* only has any effect if the position feedback interface is being used with a rotary device (*P1 Linear Feedback Select (1x.051)* = 0).

**P1 Device Type (1x.038) : AB, AB Servo**

*P1 Rotary Lines Per Revolution (1x.034)* should be set to the number of lines per revolution for the encoder connected to the *P1 position feedback interface*.

**P1 Device Type (1x.038) : FD, FR, FD Servo, FR Servo**

*P1 Rotary Lines Per Revolution (1x.034)* should be set to the number of lines per revolution for the encoder connected to the *P1 position feedback interface* divided by 2.

\* BiSS is not currently supported.

**P1 Device Type (1x.038) : SC, SC Servo, SC Hiperface, SC EnDat, SC SSI, SC BiSS\***

*P1 Rotary Lines Per Revolution (1x.034)* should be set to the number of sine waves per revolution for the encoder connected to the *P1 position feedback interface*.

**P1 Device Type (1x.038) : Any other device type**

*P1 Rotary Lines Per Revolution (1x.034)* has no effect.

<b>1x.035</b>	<b>P1 Comms Bits</b>		
Minimum	0	Maximum	48
Default	0	Units	
Type	8 Bit User Save	Update Rate	Background read, auto-configuration write
Display Format	None	Decimal Places	0
Coding	RW		

**P1 Device Type (1x.038) : SC Hiperface, EnDat, SC EnDat, SSI, SC SSI, BiSS\*, SC BiSS\***

*P1 Comms Bits (1x.035)* should be set to the total number of bits of position information in the comms message from the encoder. If SSI communications is being used this should include any leading or trailing zeros and the power supply alarm bit if present. If BiSS communication is being used this should include any leading zeros or alignments bits but not the warning bit, error bit or CDS bit. (See **1x.038**).

**P1 Device Type (1x.038) : Any other device type**

*P1 Comms Bits (1x.035)* : has no effect.

<b>1x.036</b>	<b>P1 Supply Voltage</b>		
Minimum	0	Maximum	3
Default	0	Units	
Type	8 Bit User Save	Update Rate	Background read
Display Format	None	Decimal Places	0
Coding	RW, Txt		

<b>Value</b>	<b>Text</b>
0	5 V
1	8 V
2	15 V
3	Disabled

*P1 Supply Voltage (1x.036)* sets the level for the supply voltage output. To ensure that the maximum voltage for the position feedback device is not accidentally exceeded, the device should be disconnected from the drive when the level is being adjusted.

\* BiSS is not currently supported.

<b>1x.037</b>		<b>P1 Comms Baud Rate</b>	
Minimum	0	Maximum	8
Default	2	Units	Baud
Type	8 Bit User Save	Update Rate	Background read, Auto-configuration write
Display Format	None	Decimal Places	0
Coding	RW, Txt		

Value	Text
0	100 k
1	200 k
2	300 k
3	400 k
4	500 k
5	1 M
6	1.5 M
7	2 M
8	4 M

*P1 Comms Baud Rate (1x.037)* defines the baud rate used for encoder communications. Restrictions are applied to the baud rate for different feedback devices, and so the baud rate may be different to the parameter value.

**P1 Device Type (1x.038) : SC Hiperface**

A fixed baud rate of 9600 baud is always used with this type of encoder so *P1 Comms Baud Rate (1x.037)* has no effect.

**P1 Device Type (1x.038) : SC SSI, SC EnDat, SC BiSS\***

Any baud rate that is within the range specified for the encoder may be used. The data from the encoder is not used for time critical functions, and so it is recommended that the default value of 300k baud is used unless this needs to be reduced because of a limitation imposed by the encoder.

**P1 Device Type (1x.038) : EnDat, BiSS\*, SSI**

Any baud rate that is within the range specified for the encoder may be used. The line delay is measured during initialization, and used to compensate this delay during communications with the encoder. Therefore there is no timing based restriction on the length of the cable between the position feedback interface and the encoder. However, care should be taken to ensure that the wiring arrangement and the type of cable used are suitable for the selected baud rate and the distance between the position interface and the encoder. See *P1 Low Speed Update Rate Active (1x.063)* for more details on timing restrictions related to the drive sample times.

**P1 Device Type (1x.038) : Any other device**

*P1 Comms Baud Rate (1x.037)* has no effect.

\* BiSS is not currently supported.

<b>1x.038</b>	<b>P1 Device Type</b>		
Minimum	0	Maximum	17
Default	3	Units	
Type	8 Bit User Save	Update Rate	Background read
Display Format	None	Decimal Places	0
Coding	RW, Txt		

Value	Text
0	AB
1	FD
2	FR
3	AB Servo
4	FD Servo
5	FR Servo
6	SC
7	SC Hiperface
8	EnDat
9	SC EnDat
10	SSI
11	SC SSI
12	SC Servo
13	BiSS*
14	Drive P1
15	Reserved
16	Reserved
17	SC BiSS*

*P1 Device Type (1x.038)* should be set up to match the device connected to the drive P1 position feedback interface. Table 7-2 on page 65 describes the position feedback types supported by the P1 position feedback interface.

\* BiSS is not currently supported.



**Table 7-2 P1 Position feedback types**

P1 Device Type (1x.038)	Signals	Position feedback type	Communications
0: AB	Quadrature	Incremental	None
1: FD	Frequency and direction	Incremental	None
2: FR	Forward and reverse	Incremental	None
3: AB Servo	Quadrature and commutation	Absolute commutation signals with incremental	None
4: FD Servo	Frequency and direction, and commutation	Absolute commutation signals with incremental	None
5: FR Servo	Forward and reverse, and commutation	Absolute commutation signals with incremental	None
6: SC	SINCOS	Incremental SINCOS	None
7: SC Hiperface	SINCOS and Hiperface comms	Absolute comms with incremental SINCOS	Hiperface
8: EnDat	EnDat comms	Absolute comms	EnDat 2.1 EnDat 2.2
9: SC EnDat	SINCOS and EnDat comms	Absolute comms with incremental SINCOS	EnDat 2.1
10: SSI	SSI comms	Absolute comms	SSI
11: SC SSI	SINCOS and SSI comms	Absolute comms with incremental SINCOS	SSI
12: SC Servo	SINCOS and commutation	Absolute commutation signals with incremental	None
13: BiSS*	BiSS* comms	Absolute comms	BiSS*
14: Drive P1	N/A	N/A	None
15: Reserved	N/A	N/A	None
16: Reserved	N/A	N/A	None
17: SC BiSS*	SINCOS and BiSS* comms	Absolute comms with incremental SINCOS	BiSS*

**Position feedback type:**

**Incremental**

Position devices that provide incremental feedback do not give absolute position feedback. The position is zero at power-up and accumulates the change of position from that point on. These devices are suitable for motor control in RFC-A mode. They can also be used for RFC-S mode, but some form of phasing auto-tune is required each time the position feedback is initialized.

**Absolute commutation signals with incremental**

Position devices with commutations signals are intended to provide absolute position feedback for motor control in RFC-S mode. If one of these devices is used for RFC-A mode the commutation signals are ignored. The position information given in *P1 Revolution/Pole Pitch Counter (1x.028)*, *P1 Position (1x.029)* and *P1 Fine Position (1x.030)* appears as though the position feedback device is an incremental type in that it is initialized to zero at power-up and then accumulates the change of position from that point on. The commutation signals are used directly by the motor control algorithms in RFC-S mode to determine the motor position after position feedback initialization.

\* BiSS is not currently supported.

How to use this guide
Safety Information
Introduction
Mechanical Installation
Electrical Installation
Getting started
<b>Parameters</b>
Advanced operation
Diagnostics
Terminal data
Index

There must be one period of the commutation signals for each pole pair for a rotary motor (i.e. 3 commutation signal periods per revolution for a 6 pole motor), or one period of the commutation signals must be equal to the motor pole pitch for a linear motor.

It should be noted that for a movement of up to  $\frac{1}{3}$  of the commutation signal period after position feedback Initialization the maximum motor torque is limited to 0.866 of the maximum possible torque.

### **Incremental SINCOS**

An incremental SINCOS encoder can be used in the same way as an AB incremental encoder, except that the position resolution is increased with interpolation. These devices are suitable for motor control in RFC-A mode. They can also be used for RFC-S mode, but some form of phasing auto-tune is required each time the position feedback is initialized.

### **Absolute comms with incremental SINCOS**

The absolute position is obtained after position feedback Initialization via the comms interface and then after that point by tracking the incremental change from the sine wave signals. Interpolation is used to increase the position resolution. The comms interface can be used to check the position derived from the sine waves. It can also be used for bi-directional transfer of data between the drive and encoder (except SSI comms). These devices can be used for motor control in RFC-A or RFC-S modes.

### **Absolute comms**

The absolute position is obtained at all times via the encoder comms. The comms interface can also be used for bi-directional transfer of data between the drive and the encoder (except SSI mode). These devices can be used for motor control in RFC-A or RFC-S modes.

### **Communications:**

#### **Hiperface**

Hiperface is an asynchronous bi-directional communications protocol that is only used with incremental sine waves. Therefore it can be used to check the position derived from the sine waves or for bi-directional transfer of data between the drive and encoder. A checksum is provided for error checking.

#### **EnDat 2.1**

EnDat 2.1 is a synchronous bi-directional communications protocol that is intended to be used with incremental sine waves. Therefore it can be used to check the position derived from the sine waves or for bi-directional transfer of data between the drive and encoder. It can be used as an absolute comms only type position feedback interface, but the resolution of the position feedback using this method may be limited. If it is used in this way it is not possible to use the position feedback via comms at the same time as communicating with the encoder for data transfer. A CRC is provided for error checking.

#### **EnDat 2.2**

EnDat 2.2 is a synchronous bi-directional communications protocol that is intended to be used alone. It is possible to obtain position feedback at the same time as communicating with the encoder for data transfer. A CRC is provided for error checking.

## BiSS C Mode\*

BiSS is a synchronous bi-directional communications protocol that is intended to be used alone. It is possible to obtain position feedback at the same time as communicating with the encoder for data transfer. A CRC is provided for error checking. The BiSS C frame must comply with the following restrictions:

- No unused bits between the multi turn and single turn bits.
- 1 error bit and 1 warning bit between the position bits and CRC
- No other information such as life counters
- 6-bit CRC with polynomial 0x43 and starting value of 0x00.

**Figure 7-5 BiSS C communication protocol**

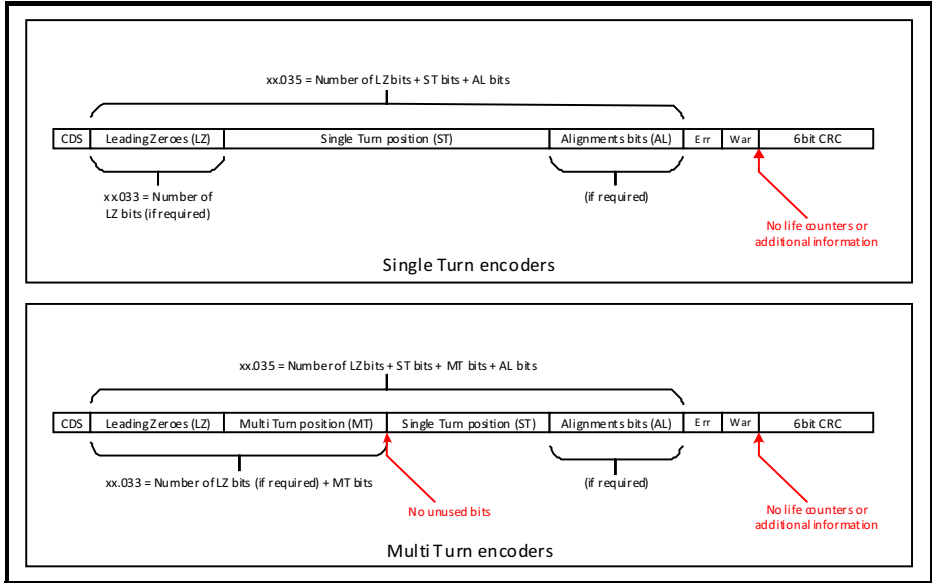

## SSI

SSI is a uni-directional communications protocol that is intended to be used alone. It is only possible to obtain the position information from the encoder and it is not possible to transfer data between the drive and the encoder. No error checking is provided by the SSI protocol, and so encoders based on this interface are not recommended for new applications.

### Other:

#### Drive P1

Drive P1 is used to allow the SI-Universal Encoder module to provide hardware encoder simulation output with scaling using the P1 position interface on the drive as the source. In this mode, the P1 position interface on the SI-Universal Encoder module is disabled and cannot be used as an interface for a position feedback device. In all other conditions, the P1 position interface on the module is available for use as a position feedback interface.

The table below details the availability of the P1 position interface for the different types of encoder simulation output.

\* BiSS is not currently supported.

**Table 7-3 Encoder simulation output mode**

Encoder Simulation Mode	Encoder Simulation Source	Scaling Required	Availability of the P1 interface on the module
Hardware	Drive P1 ( <b>03.029</b> )	Yes	No
Hardware	Drive P1 ( <b>03.029</b> )	No	Yes
Hardware	Module P1 ( <b>1x.029</b> )	Yes	Yes
Software	Any	Yes	Yes

<b>1x.039</b>	<b>P1 Termination Select</b>		
Minimum	0	Maximum	2
Default	1	Units	
Type	8 Bit User Save	Update Rate	Background read
Display Format	None	Decimal Places	0
Coding	RW		

*P1 Termination Select (1x.039)* is used to enable or disable the terminations on the position feedback interface inputs. The function of *P1 Termination Select (1x.039)* depends on the position feedback device type selected in *P1 Device Type (1x.038)* as shown below.

Terminals 5/6 have selectable pull-apart resistors which follow the same state as the termination resistors for terminals 5/6, unless described differently below.

**P1 Device Type (1x.038) : AB, FD, FR, AB Servo, FD Servo, FR Servo**

Terminal	Input	1x.039 = 0	1x.039 = 1	1x.039 = 2
1/2 & 3/4	A1 & B1	Disabled	Enabled	Enabled
5/6	Z1	Disabled	Disabled	Enabled

U1, V1 & W1 terminations (terminals 7/8, 9/10 & 11/12) are always enabled for AB Servo, FD Servo and FR Servo encoders.

**P1 Device Type (1x.038) : SC, SC Servo**

Terminal	Input	1x.039 = 0	1x.039 = 1	1x.039 = 2
1/2 & 3/4	Cos1 & Sin1	Disabled	Enabled	Enabled
5/6	Z1	Disabled	Disabled	Enabled

U1, V1 & W1 (terminals 7/8, 9/10 & 11/12) terminations are always enabled for SC Servo encoders.

**P1 Device Type (1x.038) : SC Hiperface, SC EnDat, SC SSI, SC BiSS\***

Terminal	Input	1x.039 = 0	1x.039 = 1	1x.039 = 2
1/2 & 3/4	Cos1 & Sin1	Disabled	Enabled	Enabled
5/6	D1	Enabled	Enabled	Enabled

For SC EnDat, SC BiSS\* and SC SSI encoder the pull-apart resistors on the D1 input/output (terminals 5/6) are always disabled, and for SC Hiperface encoders the pull-apart resistors on the D1 input/output (terminals 5/6) are always enabled.

\* BiSS is not currently supported.

## P1 Device Type (1x.038) : EnDat, BiSS\*, SSI

Terminal	Input	1x.039 = 0	1x.039 = 1	1x.039 = 2
1/2 & 3/4	D1/CLK1	Enabled	Enabled	Enabled
5/6	Z1	Disabled	Disabled	Enabled

If the *P2 Device type (2x.038)* is set to EnDat, BiSS\* or SSI and the encoder simulation output is enabled, then the Z1 input becomes the data (D2) input for the P2 position interface and termination resistors are always enabled and pull-apart resistors are always disabled.

1x.040	P1 Error Detection Level		
Minimum	0 (Display: 00000)	Maximum	31 (Display: 11111)
Default	1 (Display: 00001)	Units	
Type	8 Bit User Save	Update Rate	Background read
Display Format	Binary	Decimal Places	0
Coding	RW		

This parameter can be used to enable or disable position feedback trip functions as follows:

Bit	Function
0	Enable wire break detection
1	Enable phase error detection
2	Enable SSI power supply alarm bit monitor
3	Disable trips <i>Encoder PS to SSI Error P1</i>
4	Disable the <i>Setup Changed P1</i> trip

Bits 3 and 4 do not prevent the device from becoming un-initialized. The trip is suppressed, but the device is still un-initialised and this is indicated by the appropriate bit for the position feedback interface in Position Feedback Initialized (**1x.076**). Bits 0 to 2 enable the functions indicated and allow trips to be initiated if the trip conditions occurs. However, the disable function controlled by Bit 3 takes precedence and will override the trip even if it is enabled by Bit 0 to 2.

If P1 Error Detection Level (**1x.040**) bit 4 is set then:

- The drive will not trip if any of the setup parameters are changed whilst the drive is in the Inhibit or Ready state. The encoder will be automatically re-configured with the new setting (no reset required).
- The drive will trip if any of the setup parameters are changed whilst running.
- The *Setup Changed P1* trip suppression is only active with AB, FD, FR, AB Servo, FDServo and FR Servo type encoders, all other encoders will trip the drive if one of the setup parameters has changed whether the drive is running or disabled.

\* BiSS is not currently supported.

## Encoder trips

The following table shows trips that can be initiated that are related to the position feedback interface. All trips will be prefixed by "Slotx Error", where x defines the slot number where the module is fitted.

<b>Module trip</b>	<b>Encoders</b>	<b>Reason for error</b>
* <i>Enc PS Overload</i>	All	Power supply short circuit
* <i>Wire break P1</i> * <i>Wire break A P1</i> * <i>Wire break B P1</i> * <i>Wire break Z P1</i>	AB, FD, FR, AB Servo, FD Servo, FR Servo	+Hardware wire-break detect on A1, B1 and Z1 inputs <sup>1</sup> . There is no wire break detection on the U1, V1 and W1 commutation inputs
	SC, SC Servo, SC Hiperface, SC EnDat, SC SSI, SC BiSS***	+Software wire break detection on sine wave signals. There is no wire break detection on the U1, V1 and W1 commutation inputs
* <i>UVW phase P1</i> <i>Phase offset P1</i>	AB Servo, FD Servo, FR Servo, SC Servo	+Phase error <sup>2</sup>
	SC Hiperface, SC EnDat, SC SSI	+Sine/cosine phase error <sup>3</sup>
* <i>Comms timeout P1</i>	SC Hiperface, SC EnDat, EnDat, BiSS***	Comms timeout
* <i>CRC error P1</i>	SC Hiperface, SC EnDat, EnDat, BiSS***	Checksum/CRC error
	SC SSI, SSI	Not ready at start of position transfer (i.e. data input not one)
* <i>SSI error P1</i>	SC Hiperface, SC EnDat, EnDat, BiSS***	The encoder has indicated an error
	SSI, SC SSI	+Power supply alarm bit active
** <i>Setup changed P1</i>	All	A set-up parameter for the device has been changed.
<i>Comms period P1</i>	EnDat, SSI, BiSS***	<i>P1 Device Type (1x.038)</i> , <i>P1 Comms Bits (1x.035)</i> , <i>P1 Comms Baud Rate (1x.037)</i> , <i>P1 Calculation Time (1x.060)</i> , <i>P1 Recovery Time (1x.061)</i> , <i>P1 Line Delay Time (1x.062)</i> and <i>P1 User Comms Enable (1x.067)</i> are used to determine the time taken for the communications exchange with the encoder. If this time exceeds 250 µs a <i>Comms Period P1</i> trip is initiated.
<i>Encoder type P1</i>	SC Hiperface, BiSS***	The encoder could not be identified during auto-configuration
<i>Rotary LPR P1</i> <i>Line pitch P1</i> <i>Turns bits P1</i> <i>Comms bits P1</i>	SC Hiperface, SC EnDat, EnDat, BiSS***	Data read from the position feedback device during auto-configuration is out of range

+ These trips can be enabled or disabled with *P1 Error Detection Level (1x.040)* bits 0 to 2.

\* These trips can be enabled or disabled with *P1 Error Detection Level (1x.040)* bit 3.

\*\* This trip can be enabled or disabled with *P1 Error Detection Level (1x.040)* bit 4.

\*\*\* BiSS is not currently supported.

1. If the terminations are not enabled on the A1, B1 or Z1 inputs, the wire break system will not operate. (Note that as default the Z1 input terminations are disabled to disable wire break detection on this input.)
2. Phase error detection for AB Servo, FD Servo, FR Servo or SC Servo encoders monitors the relationship between the position from the incremental signals and the commutation signals to ensure that the incremental pulses have been counted correctly. The error is detected if the incremental position moves by 10° electrical with respect to the position defined by the UVW commutation signals. The trip is initiated if the error is detected for 10 consecutive samples taken once every 100 ms. This system should not be used unless 10° electrical is less than one encoder line (AB Servo), or two lines (FD Servo, FR Servo), or one sine wave (SC Servo) or else spurious *UVW phase P1* trips will occur.
3. Phase error detection for SINCOS encoders with comms monitors the relationship between the position derived from the sine waves with the position derived via comms. The encoder is interrogated via comms and the comparison is made once per second. If the error is greater than 10° electrical for 10 consecutive samples the trip is initiated. This system should not be used unless 10° electrical is less than one sine wave or else spurious *Phase offset P1* trips will occur.

**Wire-break detection**

It may be important to detect a break in the connections between the drive and the position feedback device. This feature is provided for most position feedback devices either directly or indirectly as detailed in the table below.

**Table 7-4 Wire-break detection**

Device	Detection method	Trip produced
AB, FD, FR, AB Servo, FD Servo, FR Servo	Hardware detectors on the A1, B1 and Z1 signal detect a wire break.	<i>Wire break A P1</i> <i>Wire break B P1</i> <i>Wire break Z P1</i>
SC, SC Servo, SC Hiperface, SC EnData, SC SSI	The magnitudes of the sine wave signals are monitored and if $\text{Sine}^2 + \text{Cosine}^2$ is less than the value produced by two valid waveforms with a differential peak to peak magnitude of 0.25V (¼ of the nominal level) then a trip is initiated. This detects wire break in the sine and cosine connections.	<i>Wire break P1</i>
SC Hiperface, SC EnDat, EnDat, BiSS*	Wire break in the comms link is detected by a CRC or timeout error.	<i>Comms error P1</i>
SSI, SC SSI	Wire break detection in the comms is difficult with these devices. However, if power supply alarm bit monitoring is enabled, the drive will be looking for a one at the start of the message and a zero to indicate that the power supply is operational. If the clock stops or the data line is disconnected, the data input to the drive may stay in one state or the other and cause a trip.	<i>SSI error P1</i>

\* BiSS is not currently supported.

### Position feedback power supply trips

The position feedback power supply from the drive can be switched off by the drive either because the power supply is overloaded (*Enc PS Overload* trip) or because the internal 24 V supply within the drive is overloaded (*drive PSU 24V* trip). The internal 24 V supply in the drive provides power for the position feedback power supply, user 24 V output, digital I/O, option modules etc.

To ensure that an *Enc PS Overload* trip is not initiated when the internal 24 V is overloaded, and subsequently switched off by the drive, there is a delay of 40 ms in the detection of *Enc PS Overload* trip. It is possible for other position feedback trips, such as wire break detection (i.e. *Wire break* trip), to occur when the power supply is removed from the position feedback device.

Therefore overloading the internal 24 V supply on the drive or the position feedback supply could result in an immediate *Wire break* trip. To ensure that the correct reason for the trip is given, *Enc PS Overload* trip will override an existing *Wire Break* trip to *SSI error* trip. This means that both the original trip (*Wire Break* trip to *SSI error* trip) and then the new trip (*Enc PS Overload*) are stored in the trip log.

### Setup Changed P1 trips

If P1 Error Detection Level (**1x.040**) bit 4 is set then:

- The drive will not trip if any of the setup parameters are changed whilst the drive is in the Inhibit or Ready state. The encoder will be automatically re-configured with the new setting (no reset required).
- The drive will trip if any of the setup parameters are changed whilst running.
- The *Setup Changed P1* trip suppression is only active with AB, FD, FR, AB Servo, FDServo and FR Servo type encoders, all other encoders will trip the drive if one of the setup parameters has changed whether the drive is running or disabled.

1x.041	P1 Auto-configuration Select		
Minimum	0	Maximum	1
Default	1	Units	
Type	8 Bit User Save	Update Rate	Background read
Display Format	None	Decimal Places	0
Coding	RW, Txt		

Value	Text
0	Disabled
1	Enabled



### **P1 Device Type (1x.038): SC Hiperface, SC EnDat, EnDat, BiSS\***

If auto-configuration has not been disabled (i.e. *P1 Auto-configuration Select (1x.041)* is not 0) then during position feedback initialization the encoder is interrogated to determine whether the encoder is a rotary or linear encoder and *P1 Linear Feedback Select (1x.051)* is set up appropriately. Then the following parameters are set up based on information from the encoder:

<b>Rotary</b>	<b>Linear</b>
<i>P1 Rotary Turns Bits (1x.033)</i>	<i>P1 Linear Comms Pitch (1x.052)</i>
<i>P1 Rotary Lines Per Revolution (1x.034)</i>	<i>P1 Linear Line Pitch (1x.053)</i>
<i>P1 Comms Bits (1x.035)</i>	<i>P1 Comms Bits (1x.035)</i>
	<i>P1 Linear Comms And Line Pitch Units (1x.054)</i>

The timing for the encoder is now set-up as shown in the table below:

<b>Comms Protocol</b>	<b>Actions taken</b>
EnDat 2.1	<i>P1 Calculation Time (1x.060)</i> = From the encoder <i>P1 Recovery Time (1x.061)</i> = 30 $\mu$ s Line delay measured and result written to <i>P1 Line Delay Time (1x.062)</i>
EnDat 2.2	<i>P1 Calculation Time (1x.060)</i> = From the encoder <i>P1 Recovery Time (1x.061)</i> = 4 $\mu$ s and the recovery time within the encoder is set up to the shortest value of 3.75 $\mu$ s if the <i>P1 Comms Baud Rate (1x.037)</i> is 1M or more. Line delay measured and result written to <i>P1 Line Delay Time (1x.062)</i>
BiSS*	<i>P1 Recovery Time (1x.061)</i> = 12 $\mu$ s <i>P1 Calculation Time (1x.060)</i> = 5 $\mu$ s <i>P1 Comms Baud Rate (1x.037)</i> set to the minimum baud rate in order to allow the position time to be shorter than 40 $\mu$ s and therefore <i>P1 Low Speed Update Rate Active (1x.063)</i> is set to 1. Line delay measured and result written to <i>P1 Line Delay Time (1x.062)</i>

\* BiSS is not currently supported.

Once these parameters have been set up, it should be possible for the drive to operate correctly with the encoder. Auto-configuration occurs as part of the position interface initialization if selected, and should the auto-configuration fail (i.e. communications cannot be established) then initialization will not be completed. If initialization has not been completed successfully by the time the drive is enabled, a *Setup changed P1* trip occurs.

For SC Hiperface encoders the drive must identify the encoder model number to perform auto-configuration.

If communications are established but the drive cannot recognise the encoder model, an *Encoder type P1* trip is produced immediately.

If auto-configuration is disabled ((i.e. *P1 Auto-configuration Select (1x.041)* = 0) then none of the above actions are carried out except for the line delay measurement.

### **P1 Device Type (1x.038): All other device types**

*P1 Auto-configuration Select (1x.041)* has no effect.

<b>1x.042</b>		<b>P1 Feedback Filter</b>	
Minimum	0	Maximum	5
Default	0	Units	
Type	8 Bit User Save	Update Rate	Background read
Display Format	None	Decimal Places	0
Coding	RW, Txt		

Value	Text
0	Disabled
1	1 ms
2	2 ms
3	4 ms
4	8 ms
5	16 ms

*P1 Feedback Filter (1x.042)* defines the time period for a sliding window filter that may be applied to the feedback taken from the drive P1 position feedback interface.

This is particularly useful in applications where the drive encoder is used to give speed feedback for the speed controller and where the load includes a high inertia and hence the speed controller gains are very high. Under these conditions without a filter on the feedback, it is possible for the speed loop output to change constantly from one current limit to the other and lock the integral term of the speed controller.

<b>1x.043</b>		<b>P1 Maximum Reference</b>	
Minimum	0	Maximum	50000
Default	3000	Units	
Type	16 Bit User Save	Update Rate	Background read
Display Format	None	Decimal Places	0
Coding	RW, BU		

The speed feedback from the *P1 position feedback interface* can be used as a source to control a parameter. The speed feedback is scaled to give a value as a percentage of *P1 Maximum Reference (1x.043)* in 0.1 % units which is displayed in *P1 Reference (1x.045)*. The value is then scaled by the *P1 Reference Scaling (1x.044)* and then routed to the destination defined by *P1 Reference destination (1x.046)*.

Normally the destination is updated every 4 ms, but if the destination is the *Hard Speed Reference (03.022)* on the drive, *P1 Maximum Reference (1x.043)* = VM\_SPEED\_FREQ\_REF[MAX] and *P1 Reference Scaling (1x.044)* = 1.000 it is updated every 250  $\mu$ s. Although the hard speed reference is updated every 250  $\mu$ s internally a value in rpm or mm/s is written to *Hard Speed Reference (03.022)* on the drive every 4  $\mu$ s for indication only.

The value transferred to the hard speed reference is written in internal units as a change of position in  $1/2^{32}$  revolution units over a time period of 250  $\mu$ s giving a speed resolution of  $55.9 \times 10^{-6}$  rpm.

<b>1x.044</b>		<b>P1 Reference Scaling</b>	
Minimum	0.000	Maximum	4.000
Default	1.000	Units	
Type	16 Bit User Save	Update Rate	Background read
Display Format	None	Decimal Places	3
Coding	RW		

See *P1 Maximum Reference (1x.043)*.

<b>1x.045</b>		<b>P1 Reference</b>	
Minimum	-100.0	Maximum	100.0
Default		Units	%
Type	16 Bit Volatile	Update Rate	4 ms write
Display Format	None	Decimal Places	1
Coding	RO, FI, ND, NC, PT		

See *P1 Maximum Reference (1x.043)*.

<b>1x.046</b>		<b>P1 Reference Destination</b>	
Minimum	0.000	Maximum	59.999
Default	0.000	Units	
Type	16 Bit User Save	Update Rate	Drive reset read
Display Format	None	Decimal Places	3
Coding	RW, DE, PT, BU		

See *P1 Maximum Reference (1x.043)*.

<b>1x.047</b>		<b>P1 SSI Incremental Mode</b>	
Minimum	0	Maximum	1
Default	0	Units	
Type	1 Bit User Save	Update Rate	Background read
Display Format	None	Decimal Places	0
Coding	RW		

***P1 Device Type (1x.038) : EnDat, BiSS\****

*P1 SSI Incremental Mode (1x.047)* has no effect and the comms modes can only operate in incremental mode, i.e. the absolute position is taken during encoder Initialization and then incremental positions are accumulated from that point on to determine the position. If there is an error in the position read from the encoder, this will be detected from the CRC check, and the position data will be ignored until correct data is available or until the drive trips after a number of consecutive errors. This prevents large spurious changes in position due to data errors, and so absolute mode is not required.

\* BiSS is not currently supported.

### **P1 Device Type (1x.038): SSI**

If *P1 SSI Incremental Mode (1x.047)* = 0 the complete absolute position is read at each sample. Care should be taken when using this mode as some unwanted effects can occur when the encoder passes through the boundary between its maximum position and zero. In this mode the encoder can be used for motor control provided at least 6 bits of turns information are provided by the encoder, otherwise an over speed trip will be produced as the position passes over the maximum position to zero boundary. *P1 Normalized Position (1x.058)* can be used for position control over this boundary provided the Normalized turns bits are set up so that the Normalized positions do not contain turns information that is not available from the encoder. As the SSI format does not include any error checking, it is not possible to detect if the position data has been corrupted by noise. The benefit of using the absolute position directly from an SSI encoder is that even if the encoder communications are disturbed by noise and position errors occur, the position will always recover the correct position after the disturbance has ended.

If *P1 SSI Incremental Mode (1x.047)* = 1 the absolute position is only taken from the encoder during Initialization. The change of position over each sample is then accumulated to determine the position. This method always gives 16 bits of turns information that can always be used without jumps in position whatever value is used as the turns bits for normalization. If noise corrupts the data from an SSI encoder it is possible to have apparent large change of position, and this can result in the turns information becoming and remaining corrupted until the encoder is re-initialized.

If an SSI encoder is used, but is not powered from the drive, and the encoder is powered up after the drive, it is possible that the first change of position detected could be large enough to cause the problems described above. This can be avoided if the encoder interface is initialized with *Initialise Position Feedback (1x.075)* after the encoder has powered up. If the encoder includes a power supply alarm bit, the power supply monitor should be enabled. This will ensure that the drive remains tripped until the encoder is powered up and the action of resetting the trip will re-initialize the encoder interface.

### **P1 Device Type (1x.038): All other device types**

*P1 SSI Incremental Mode (1x.047)* has no effect.

<b>1x.048</b>	<b>P1 SSI Binary Mode</b>		
Minimum	0	Maximum	1
Default	0	Units	
Type	1 Bit User Save	Update Rate	Background read
Display Format	None	Decimal Places	0
Coding	RW		

### **P1 Device Type (1x.038): SC SSI, SSI**

SSI encoders normally use Gray code data format. However, some encoders use binary format which may be selected by setting *P1 SSI Binary Mode (1x.048)* to one.

### **P1 Device Type (1x.038): All other device types**

*P1 SSI Binary Mode (1x.048)* has no effect.

<b>1x.049</b>		<b>P1 Additional Power-up Delay</b>	
Minimum	0.0	Maximum	25.0
Default	0.0	Units	s
Type	8 Bit User Save	Update Rate	Background read
Display Format	None	Decimal Places	1
Coding	RW, BU		

When the position feedback is initialized at power-up or at any other time, a delay is included before the information from the feedback device is used or any attempt is made to communicate with the device. The minimum delays are shown in the table below. *P1 Additional Power-up Delay (1x.049)* defines an additional delay that is added to the minimum delay.

<b>P1 Device Type (1x.038)</b>	<b>Minimum delay</b>
AB, FD, FR AB Servo, FD Servo, FR Servo, SC, SC Servo	100 ms
SC Hiperface	150 ms
EnDat, SC EnDat SSI, SC SSI, SC BiSS*, BiSS*	1.3 s

<b>1x.050</b>		<b>P1 Feedback Lock</b>	
Minimum	0	Maximum	1
Default	0	Units	
Type	1 Bit User Save	Update Rate	Background read
Display Format	None	Decimal Places	0
Coding	RW		

If *P1 Feedback Lock (1x.050)* = 1 then *P1 Revolution/Pole Pitch Counter (1x.028)*, *P1 Position (1x.029)* and *P1 Fine Position (1x.030)* are not updated. If *P1 Feedback Lock (1x.050)* = 0 then these parameters are updated normally.

<b>1x.051</b>		<b>P1 Linear Feedback Select</b>	
Minimum	0	Maximum	1
Default	0	Units	
Type	1 Bit User Save	Update Rate	Background read, Auto-configuration write
Display Format	None	Decimal Places	0
Coding	RW		

If *P1 Linear Feedback Select (1x.051)* = 0 then the drive *P1 position feedback interface* is configured to operate with a rotary position feedback device. *P1 Rotary Turns Bits (1x.033)* and *P1 Rotary Lines Per Revolution (1x.034)* should be used to set up the position feedback interface.

If *P1 Linear Feedback Select (1x.051)* = 1 then the position feedback interface is configured to operate with a linear position feedback device. *P1 Linear Comms Pitch (1x.052)* and *P1 Linear Line Pitch (1x.053)* should be used to set up the position feedback interface.

\* BiSS is not currently supported.

<b>1x.052</b>	<b>P1 Linear Comms Pitch</b>		
Minimum	0.001	Maximum	100.000
Default	0.001	Units	
Type	32 Bit User Save	Update Rate	Background read, Auto-configuration write
Display Format	None	Decimal Places	3
Coding	RW		

**P1 Device Type (1x.038): SC Hiperface, EnDat, SC EnDat, SSI, SC SSI, BiSS\*, SC BiSS\***

*P1 Linear Comms Pitch (1x.052)* is used to define the distance covered by the least significant bit of the position information in a comms message from a linear encoder. The units used by this parameter are defined by *P1 Linear Comms And Line Pitch Units (1x.054)*.

**P1 Device Type (1x.038) : Any other device**

*P1 Linear Comms Pitch (1x.052)* has no effect.

<b>1x.053</b>	<b>P1 Linear Line Pitch</b>		
Minimum	0.001	Maximum	100.000
Default	0.001	Units	
Type	32 Bit User Save	Update Rate	Background read, Auto-configuration write
Display Format	None	Decimal Places	3
Coding	RW		

*P1 Linear Line Pitch (1x.053)* only has any effect if the position feedback interface is being used with a linear device (i.e. *P1 Linear Feedback Select (1x.051)* = 1) and should be used to define the distances listed below for each type of device. The units used by this parameter are defined by *P1 Linear Comms And Line Pitch Units (1x.054)*.

**P1 Device Type (1x.038) : AB, AB Servo**

*P1 Linear Line Pitch (1x.053)* should be set to the distance covered by one line period on the encoder.

**P1 Device Type (1x.038) : FD, FR, FD Servo, FR Servo**

*P1 Linear Line Pitch (1x.053)* should be set to the distance covered by two line periods on the encoder.

**P1 Device Type (1x.038) : SC, SC Hiperface, SC EnDat, SC SSI, SC Servo, SC BiSS\***

*P1 Linear Line Pitch (1x.053)* should be set to the distance covered by one sine wave period on the encoder.

**P1 Device Type (1x.038) : Any other device**

*P1 Linear Line Pitch (1x.053)* has no effect.

\* BiSS is not currently supported.

<b>1x.054</b>		<b>P1 Linear Comms And Line Pitch Units</b>	
Minimum	0	Maximum	1
Default	0	Units	
Type	8 Bit User Save	Update Rate	Background read
Display Format	None	Decimal Places	0
Coding	RW, Txt		

Value	Text
0	millimeters
1	micrometers

*P1 Linear Comms And Line Pitch Units (1x.054)* defines the units used by *P1 Linear Comms Pitch (1x.052)* and *P1 Linear Line Pitch (1x.053)* in either millimeters or micro metres.

<b>1x.055</b>		<b>P1 Pole Pitch</b>	
Minimum	0.01	Maximum	1000.00
Default	10.00	Units	mm
Type	32 Bit User Save	Update Rate	Background read
Display Format	None	Decimal Places	2
Coding	RW		

*P1 Pole Pitch (1x.055)* is used to define the distance equivalent to one pole for linear position feedback devices. If the linear position feedback device is being used with a linear motor, then *P1 Pole Pitch (1x.055)* should be set to the pole pitch of the motor.

<b>1x.056</b>		<b>P1 Feedback Reverse</b>	
Minimum	0	Maximum	1
Default	0	Units	
Type	1 Bit User Save	Update Rate	Background read
Display Format	None	Decimal Places	0
Coding	RW		

If *P1 Feedback Reverse (1x.056)* = 1 the position feedback is negated. This can be used to reverse the direction of the position feedback.

<b>1x.057</b>		<b>P1 Normalization Turns</b>	
Minimum	0	Maximum	16
Default	16	Units	
Type	8 Bit User Save	Update Rate	Background read
Display Format	None	Decimal Places	0
Coding	RW		

The combination of *P1 Revolution/Pole Pitch Counter (1x.028)*, *P1 Position (1x.029)* and *P1 Fine Position (1x.030)* give the position feedback as a 48 bit value. This position cannot be read atomically without locking the position feedback (*P1 Feedback Lock (1x.050)* = 1) and it cannot be used directly by the Advanced Motion Controller.

It is useful to be able to create 32 bit position values that can be held by a single parameter as this value can be accessed atomically and can be used directly by the Advanced Motion Controller.

*P1 Normalization Turns (1x.057)* defines the number of turns bits included in the following parameters.

*P1 Normalized Position (1x.058)*

*P1 Normalized Marker Position (1x.059)*

*F1 Normalized Freeze Position (1x.103)* if P1 is the source position for freeze function F1

*F2 Normalized Freeze Position (1x.108)* if P1 is the source position for freeze function F2

<b>1x.058</b>	<b>P1 Normalized Position</b>		
Minimum	-2147483648	Maximum	2147483647
Default		Units	
Type	32 Bit Volatile	Update Rate	250 µs write
Display Format	None	Decimal Places	0
Coding	RO, ND, NC, PT		

*P1 Normalized Position (1x.058)* is the position taken from the position feedback device including the effect of the marker function. See *P1 Normalization Turns (1x.057)* for details of the format.

<b>1x.059</b>	<b>P1 Normalized Marker Position</b>		
Minimum	-2147483648	Maximum	2147483647
Default		Units	
Type	32 Bit Volatile	Update Rate	250 µs write
Display Format	None	Decimal Places	0
Coding	RO, ND, NC, PT		

*P1 Normalized Marker Position (1x.059)* is the value *P1 Normalized Position (1x.058)* at the last marker event provided bit 2 of *P1 Marker Mode (1x.031)* is set to 1. See *P1 Marker Mode (1x.031)* for more details.

<b>1x.060</b>	<b>P1 Calculation Time</b>		
Minimum	0	Maximum	20
Default	5	Units	µs
Type	8 Bit User Save	Update Rate	Background read, auto-configuration write
Display Format	None	Decimal Places	0
Coding	RW		

***P1 Device Type (1x.038): EnDat, BiSS\****

*P1 Calculation Time (1x.060)* is the time from the first edge of the clock signal from the position feedback interface until the encoder has calculated the position and is ready to return this information. This is used to calculate the overall time for a message interchange with the encoder. See *P1 Low Speed Update Rate Active (1x.063)* for more details.

***P1 Device Type (1x.038): Any other type of device***

*P1 Calculation Time (1x.060)* has no effect.

\* BiSS is not currently supported.



1x.061		P1 Recovery Time	
Minimum	5	Maximum	100
Default	30	Units	µs
Type	8 Bit User Save	Update Rate	Background read, auto-configuration write
Display Format	None	Decimal Places	0
Coding	RW		

**P1 Device Type (1x.038): EnDat, SSI, BiSS\***

*P1 Recovery Time (1x.061)* is the time that must be allowed after each message interchange before a new message begins.

**P1 Device Type (1x.038): Any other type of device**

*P1 Recovery Time (1x.061)* has no effect.

1x.062		P1 Line Delay Time	
Minimum	0	Maximum	5000
Default	0	Units	ns
Type	16 Bit User Save	Update Rate	Background read, position feedback initialization write
Display Format	None	Decimal Places	0
Coding	RO, NC, PT		

**P1 Device Type (1x.038) : EnDat, SC EnDat, BiSS\*, SC BiSS\***

During position feedback Initialization the transmission delay between the position feedback interface and the encoder and back again is measured and stored in *P1 Line Delay Time (1x.062)*. This value is then used to compensate for this delay so that the clock/data skew does not prevent the data from the encoder from being read. This means that longer line lengths can be used with these feedback devices provided the correct cable and connection arrangements are used.

**P1 Device Type (1x.038) : Any other type of device**

*P1 Line Delay Time (1x.062)* is always zero.

1x.063		P1 Low Speed Update Rate Active	
Minimum	0	Maximum	1
Default		Units	
Type	1 Bit Volatile	Update Rate	Background write
Display Format	None	Decimal Places	0
Coding	RO, ND, NC, PT		

\* BiSS is not currently supported.

### P1 Device Type (1x.038) : EnDat, SSI, BISS\*

There is a delay when the position information is obtained via a communications interface from an encoder. It is assumed that the position information is taken from all types of encoder at a fixed datum point during each sample period. The drive initiates the comms transfer at a suitable point in advance of the datum to ensure that the position information is available when required. Correction is then applied to the position information based on the change of position over the previous sample and the advance time so that the position appears to have been sampled at the datum. If the communications exchange, including allowing the encoder a recovery time (*P1 Recovery Time (1x.061)*), is completed in 60 µs and the time required to obtain the full position is completed in 40 µs, then the position is sampled at each current controller task and *P1 Low Speed Update Rate Active (1x.063) = 0*. Otherwise if the communication exchange is completed in 230 µs the position is sampled every 250 µs and *P1 Low Speed Update Rate Active (1x.063) = 1*.

If the complete exchange takes any longer a trip is initiated. The following table shows the calculations used by the drive to determine the necessary time to obtain the required data.

Protocol	Time for full position	Time for complete data exchange
EnDat 2.1 encoder	$t_{ST} + t_D + 10T + 2T + NtT + 5T$ where $t_{cal} \leq t_{ST} + t_D/2 + 10T$ $t_D + t_{cal} + 2T + NtT + 5T$ where $t_{cal} > t_{ST} + t_D/2 + 10T$	Time for full position + $t_m$
EnDat 2.2 encoder	$t_{ST} + t_D + 10T + 3T + NtT + 5T$ where $t_{cal} \leq t_{ST} + t_D/2 + 10T$ $t_D + t_{cal} + 3T + NtT + 5T$ where $t_{cal} > t_{ST} + t_D/2 + 10T$	Time for full position + $t_{Add} + t_m$
BISS*	$2T + t_{cal} + t_D + NtT + 10T$	Time for full position + $t_m$
SSI	$t_D + T + NtT$ ( $t_D$ cannot be measured, and so a value of 1.25µs is used)	Time for full position + $t_m$

\* BiSS is not currently supported.

Where

Value	Description	Source
$t_{ST}$	EnDat start time	For 100 k baud = 5 us, 200 k baud = 2.5 µs, for all other baud rates = 2 µs
$t_D$	Transmission delay from the drive to the encoder and back	<i>P1 Line Delay Time (1x.062)</i>
T	1 / baud rate	<i>P1 Comms Baud Rate (1x.037)</i>
$t_{cal}$	Position calculation time	<i>P1 Calculation Time (1x.060)</i>
Ns	Single turn bits for a rotary encoder	<i>P1 Comms Bits (1x.035)</i> – <i>P1 Rotary Turns Bits (1x.033)</i>
Nt	Total number of position information bits	<i>P1 Comms Bits (1x.035)</i>
$t_m$	Encoder recovery time	<i>P1 Recovery Time (1x.061)</i>
$t_{Add}$	Time for additional information	$t_{Add1} = 31T + t_{ST} + 30T$ , $t_{Add2} = 31T$ $t_{Add}$ depends on the value of <i>P1 User Comms Enable (1x.067)</i> 0/1: $t_{Add} = t_{Add1}$ 2: $t_{Add} = t_{Add1} + t_{Add2}$

## P1 Device Type (1x.038) : Any other type of device

P1 Low Speed Update Rate Active (1x.063) is always zero.

1x.064	P1 Encoder Protocol Detected		
Minimum	0	Maximum	3
Default		Units	
Type	8 Bit Volatile	Update Rate	Background write
Display Format	None	Decimal Places	0
Coding	RO, Txt, ND, NC, PT		

Value	Text
0	None
1	Hiperface
2	EnDat2.1
3	EnDat2.2

P1 Encoder Protocol Detected (1x.064) shows the encoder comms protocol detected during position feedback Initialization. If P1 Device Type (1x.038) is set to SC Hiperface then P1 Encoder Protocol Detected (1x.064) is set to the appropriate value after successful communication with the encoder during Initialization. If P1 Device Type (1x.038) is set to EnDat or SC EnDat then P1 Encoder Protocol Detected (1x.064) is set to the appropriate EnDat protocol after successful communication with the encoder during Initialization. If communications is not successful during Initialization then P1 Encoder Protocol Detected (1x.064) is set to 0 (None).

1x.067	P1 User Comms Enable		
Minimum	0	Maximum	1
Default	0	Units	
Type	8 Bit Volatile	Update Rate	Background read
Display Format	None	Decimal Places	0
Coding	RW, NC, PT		

If P1 User Comms Enable (1x.067) set to a non-zero value, it is possible to use P1 User Comms Transmit Register (1x.068) and P1 User Comms Receive Register (1x.069) to communicate with an encoder that has a Hiperface, EnDat 2.1, EnDat2.2 or BiSS\* interface. A description of how to use these registers is given below.

### P1 Device Type (1x.038): SC Hiperface, SC EnDat

Hiperface or EnDat 2.1 communications are used as appropriate if P1 User Comms Enable (1x.067) is set to a non-zero value.

### P1 Device Type (1x.038): EnDat

Communications is enabled when P1 User Comms Enable (1x.067) is set to a non-zero value.

If the encoder supports EnDat 2.2 it is possible to enable user communications at any time even if the drive is enabled.

Table 7-5 below shows the possible communication levels for different values in P1 User Comms Enable (1x.067).

\* BiSS is not currently supported.

**Table 7-5 P1 User Comms enable**

<b>P1 User Comms Enable (1x.067)</b>	<b>EnDat 2.2. communications</b>
0	Position feedback only with one piece of additional information, but user communications are not enabled and does not use this
1	Position feedback with one piece of additional information

**P1 Device Type (1x.038): BISS\***

*P1 User Comms Enable (1x.067)* has no effect

**NOTE**

See section 8.1 *Encoder communications* on page 125 for more information.

<b>1x.068</b>	<b>P1 User Comms Transmit Register</b>		
Minimum	0	Maximum	65535
Default	0	Units	
Type	16 Bit Volatile	Update Rate	Background read/write
Display Format	None	Decimal Places	0
Coding	RW, NC, PT, BU		

See *P1 User Comms Enable (1x.067)*

<b>1x.069</b>	<b>P1 User Comms Receive Register</b>		
Minimum	0	Maximum	65535
Default	0	Units	
Type	16 Bit Volatile	Update Rate	Background read/write
Display Format	None	Decimal Places	0
Coding	RW, NC, PT, BU		

See *P1 User Comms Enable (1x.067)*

<b>1x.070</b>	<b>P1 Position Feedback Signals</b>		
Minimum	0 (Display: 000000)	Maximum	63 (Display: 111111)
Default		Units	
Type	16 Bit Volatile	Update Rate	Background write
Display Format	Binary	Decimal Places	0
Coding	RO, ND, NC, PT		

*P1 Position Feedback Signals (1x.070)* shows the state of the signals from the position feedback device as given in the table below, where the signals are relevant for the type of device. *P1 Position Feedback Signals (1x.070)* is only intended as a debugging aid.

\* BISS is not currently supported.

<i>P1 Position Feedback Signals (1x.070) bits</i>	Signals
0	A or F or Cos
1	B or D or R or Sin
2	Z
3	U
4	V
5	W

For Cos and Sin signals the relevant bits of *P1 Position Feedback Signals (1x.070)* will be set when the signals are positive and cleared when the signals are negative.

<b>1x.071</b>	<b>P1 Error Detected</b>		
Minimum	0	Maximum	1
Default		Units	
Type	1 Bit Volatile	Update Rate	Background write
Display Format	None	Decimal Places	0
Coding	RO, ND, NC, PT		

*P1 Error Detected (1x.071)* is set if an error has been detected with the position feedback device connected to the P1 position interface. This parameter is useful if encoder trips have been disabled by setting bit 3 of *P1 Error Detection Level (1x.040)*. It should be noted that this bit is not set if specific trips are disabled with bits 0 to 2 of *P1 Error Detection Level (1x.040)*.

<b>1x.075</b>	<b>Initialize Position Feedback</b>		
Minimum	0	Maximum	1
Default	0	Units	
Type	1 Bit Volatile	Update Rate	Background read
Display Format	None	Decimal Places	0
Coding	RO, NC		

If *Initialise Position Feedback (1x.075)* is set to 1, any position feedback devices connected to the SI-Universal Encoder position feedback interfaces will be re-initialized.

<b>1x.076</b>	<b>Position Feedback Initialized</b>		
Minimum	0 (Display: 0000000000)	Maximum	1023 (Display: 1111111111)
Default	0 (Display: 0000000000)	Units	
Type	16 Bit Volatile	Update Rate	Background write
Display Format	Binary	Decimal Places	0
Coding	RO, NC, PT		

*Position Feedback Initialized (1x.076)* contains flags that represent the Initialization state of position feedback devices connected to the SI-Universal Encoder module. One indicates that the interface is initialized and zero indicates that the interface is not initialized.

The flags are assigned as shown below.

Bit	Position Feedback Interface
0	P1
1	P2

If a drive reset is initiated, the bits in *Position Feedback Initialized (1x.076)* are checked, and if any position feedback devices are not initialized an attempt is made to initialize them.

The following table shows the initialization process for different position feedback devices that can be connected to the drive.

Encoder types	Initialization process
AB, FD, FR	None. Initialization is immediate and is always successful. The position feedback is set to zero on initialization.
AB Servo FD Servo FR Servo SC Servo	The absolute position used to control a motor can only be defined accurately after two different changes of state of the UVW commutation signals. Initialization resets the system that ensures that the UVW signals alone will be used to define the motor position until the encoder has moved through two valid commutation signal state changes. Initialization is immediate and is always successful. The position feedback is set to zero on Initialization.
SC	The SINCOS interpolation system must be initialized. Initialization is immediate and is always successful. The position feedback is set to zero on Initialization.
SC Hiperface SC EnDat SC SSI SC BiSS*	Auto-configuration if required except SC SSI. The absolute position must be obtained via comms. This may cause a large change in position feedback. The SINCOS interpolation system must be initialized. This may have a small effect on the position feedback.
EnDat BiSS* SSI	Auto-configuration if required except SSI. The absolute position must be obtained via comms. This may cause a large change in position feedback.

1x.085	Encoder Simulation Source		
Minimum	0.000	Maximum	59.999
Default	0.000	Units	
Type	16 Bit User Save	Update Rate	Reset read
Display Format	None	Decimal Places	3
Coding	RW, PT, BU		

*Encoder Simulation Source (1x.085)* is used to select a parameter as the input to the encoder simulation system. If *Encoder Simulation Source (1x.085)* is zero then no source is selected and the encoder simulation system is disabled. The encoder simulation output connections are shared with the P1 and P2 position feedback interfaces, and so encoder simulation may be disabled because the connections are not available. See *Encoder Simulation Status (1x.086)* for details. Any parameter can be selected as the source, but it is assumed that the input is a 16 bit value with a range from 0 to 65535 or from -32768 to 32767. The source parameter is treated differently depending on the value of *Encoder Simulation Mode (1x.088)* as given in Table 7-6 *Encoder simulation source*.

\* BiSS is not currently supported.

**Table 7-6 Encoder simulation source**

<b>Encoder Simulation Mode (1x.088)</b>	<b>Description</b>
Hardware (0)	<p><i>Encoder Simulation Source (1x.085)</i> must be set to <b>(1x.029)</b> for the output to be enabled and the position from the <i>P1 position feedback interface</i> on the module (<i>P1 Position (1x.029)</i>) to be used as the source.</p> <p>The P1 input of the drive can be used as the encoder simulation source in hardware mode by setting <i>Encoder Simulation Source (1x.085)</i> to <b>3.029</b>. If scaling is to be used, then <i>P1 Device Type (1x.038)</i> must be set to <i>Drive P1</i> which will also disable the P1 position interface on the module. See <i>P1 Device Type (1x.038)</i> for more information.</p>
Lines Per Rev (1) or Ratio (2)	<p>If <i>Encoder Simulation Source (1x.085) = 1x.029 (i.e. <i>P1 Position (1x.029)</i> is the source) then <i>P1 Position (1x.029)</i> and <i>P1 Fine Position (1x.030)</i> are combined as a 16 bit value with 16 bit fractional part as the input to the encoder simulation system, which gives additional output resolution if the encoder simulation ratio is greater than unity.</i></p> <p>The encoder simulation system is intended to be used with a 16 bit source parameter. If the source of the encoder simulation system is not a 16 bit parameter then the drive uses the source parameter as follows:</p> <ul style="list-style-type: none"> <li>• 1 bit parameter: Zero extended</li> <li>• 8 bit parameter: Sign extended if BU attribute is zero (signed), otherwise zero extended (unsigned)</li> <li>• 32 bit parameter: Only the least significant word is used.</li> </ul>
SSI (3)	For SSI output mode the number of bits included in the output can be selected (see <i>Encoder Simulation Mode (1x.088)</i> for details).

Although *Encoder Simulation Source (1x.085)* is not a standard source parameter in common with other sources the actual source is only changed on a drive reset.

See section 6.3 *Encoder Simulation Output Set-up* on page 43 for further information.

<b>1x.086</b>	<b>Encoder Simulation Status</b>		
Minimum	0	Maximum	2
Default		Units	
Type	8 Bit Volatile	Update Rate	Background write
Display Format	None	Decimal Places	0
Coding	RO, Txt, ND, NC, PT		

<b>Value</b>	<b>Text</b>
0	None
1	Full
2	No Marker Pulse

The availability of the encoder simulation output on the 15 way connector on the drive is dependent on the type of feedback device selected with *P1 Device Type (1x.038)*. Priority is as follows from highest to lowest priority:

1. P1 position feedback interface
2. Encoder simulation output
3. P2 position feedback interface

How to use this guide
Safety information
Introduction
Mechanical Installation
Electrical Installation
Getting started
<b>Parameters</b>
Advanced operation
Diagnostics
Terminal data
Index

*Encoder Simulation Status (1x.086)* shows the status of the encoder simulation output.

**0: None**

The encoder simulation output is not enabled or is not available.

**1: Full**

Full encoder simulation with marker output is available.

**2: No Marker**

Encoder simulation without marker output is available.

<b>1x.087</b>		<b>Encoder Simulation Sample period</b>	
Minimum	0	Maximum	3
Default	0	Units	ms
Type	8 Bit User Save	Update Rate	Background read
Display Format	None	Decimal Places	0
Coding	RW, Txt		

<b>Value</b>	<b>Text</b>
0	0.25
1	1
2	4
3	16

The update rate of the encoder simulation system is nominally 250  $\mu$ s, i.e. the default value of the *Encoder Simulation Sample Period (1x.087)*. However, if the update rate of the source parameter is different, the encoder simulation output will consist of bursts of pulses at the update rate of the parameter. To prevent this and to give a smooth output, the update rate can be adjusted with the *Encoder Simulation Sample Period (1x.087)*. The *Encoder Simulation Sample Period (1x.087)* has no effect if the hardware mode is selected, i.e. the *Encoder Simulation Mode (1x.088) = 0*.

<b>1x.088</b>		<b>Encoder Simulation Mode</b>	
Minimum	0	Maximum	3
Default	0	Units	
Type	8 Bit User Save	Update Rate	Background read
Display Format	None	Decimal Places	0
Coding	RW, Txt		

<b>Value</b>	<b>Text</b>
0	Hardware
1	Lines Per Rev
2	Ration
3	SSI

The *Encoder Simulation Mode (1x.088)* defines the encoder simulation output as incremental signals (AB, FD or FR) derived directly via hardware, incremental signals generated via software or SSI data generated via software.

**0: Hardware**

The encoder simulation output can be derived directly in hardware from the P1 position feedback interface on the drive, or the P1 position feedback interface on the module. The output is derived from the input with negligible delay. The ratio between the input at the P1 interface and the output, is either unity or a limited number of binary divider ratios (see *Encoder Simulation Hardware Divider*



(**1x.089**)). The hardware mode only produces an output with AB, FD, FR, SC, SC Hiperface, SC EnDat or SC SSI type devices.

It should be noted that with a SINCOS source device, the output is based on the zero crossings of the sine wave inputs and does not include interpolation. If *Encoder Simulation Hardware Marker Lock* (**1x.090**) = 0, the marker output is derived directly from the marker input. If *Encoder Simulation Hardware Marker Lock* (**1x.090**) = 1 the incremental output signals are adjusted on each marker event so that the A and B markers are high with an AB type output, or alternatively F is high with an FD or FR type output.

Marker locking is not recommended if the number of lines per revolution of the encoder simulation source combined with the ratio does not give an encoder simulation output with a multiple of 4 counts per revolution (i.e. between each output marker event) for AB signals, or a multiple of 2 counts for FD or FR signals, because this causes a count error in the system receiving these signals.

The input marker pulse width is not adjusted to take account of the divider ratio, but is simply routed from the input to the output. Therefore the output marker pulse becomes shorter with respect to the output incremental signals as the divider ratio is increased.

### 1: Lines Per Rev

The encoder simulation output is derived via software from the selected source with a resolution defined by *Encoder Simulation Output Lines Per Revolution* (**1x.092**) with a minimum delay of 250  $\mu$ s which may be extended if the *Encoder Simulation Sample Period* (**1x.087**) is set up for a longer sample period. Note that the number of output lines per revolution apply to a quadrature (AB) type device, and that if FD or FR mode are selected the number of lines per revolution are 2 x *Encoder Simulation Output Lines Per Revolution* (**1x.092**). The output is derived by applying a ratio and output counter roll-over limit defined by *Encoder Simulation Output Lines Per Revolution* (**1x.092**) as shown below. The output marker is produced when the output counter is zero.

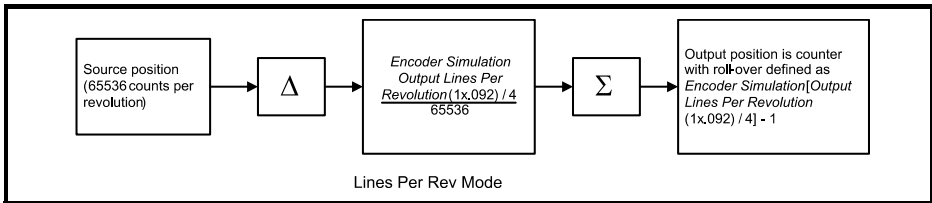

If *P1 Position* (**1x.029**) is selected as the source and *Encoder Simulation Incremental Mode Select* (**1x.091**) = 0 then the input and output counters are synchronised at power-up and when the P1 position feedback interface becomes initialized, so that the output marker is synchronised with zero position for the P1 position feedback interface. For devices that support a marker, the effect of the marker on the position can be selected using *P1 Marker Mode* (**1x.031**).

At power-up and on device initialization, there will be a step change in position from zero to the actual position from the device and the pulses necessary to make this change are produced at the encoder simulation output. If a marker event occurs that causes a step change in position, again the necessary pulses will be produced for this change of position.

Where large sudden changes occur the maximum output frequency is limited to 500 kHz, and so it may take some time for the output position to reach the input position.

This mode of operation gives an initial position change from zero position and then follows all changes of position from that point onwards, and may be used to follow the absolute position of the device connected to the P1 position feedback interface.

If *P1 Position* (**1x.029**) is selected as the source and *Encoder Simulation Incremental Mode Select*

(1x.091) = 1, then the encoder simulation output only follows the changes of source position. At power-up, on device Initialization and a marker event no additional pulses are produced to give the absolute position of the device related to zero position. The encoder simulation output marker is not synchronised to the source marker.

If a source other than *P1 Position (1x.029)* is selected *Encoder Simulation Incremental Mode Select (1x.091)* has no effect and the encoder simulation system always operates in absolute mode.

## 2: Ratio

The encoder simulation is derived in the same way as described previously for *Encoder Simulation Mode (1x.088)* = 1 (i.e. lines per rev mode), except that different parameters are used to set up the system giving more flexibility as shown below.

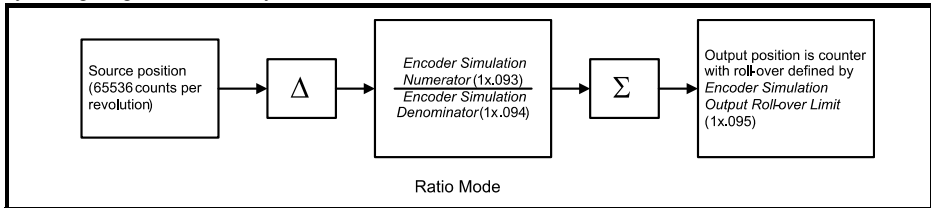

With the default settings (*Encoder Simulation Numerator (1x.093)* = 65536, *Encoder Simulation Denominator (1x.094)* = 65536 and *Encoder Simulation Output Roll-over Limit (1x.095)* = 65535) the output produces a state change each time the source parameter changes by one. The numerator and denominator can be changed to provide a different ratio between the source and the output. Output markers are produced each time the output counter is zero and the counters are synchronised in the same way as for lines per rev mode.

It is possible to control the roll-over limit of the output counter and hence the rate at which output markers are produced using *Encoder Simulation Output Roll-over Limit (1x.095)*. For example if the ratio is set to 1024/ 65536 and the roll-over limit is 1023 then one output marker is produced for every 1024 lines of output incremental signals. If the roll-over limit is changed to 512, then two output markers are produced for every 1024 lines of output incremental signals.

## 3: SSI

In this mode the B output becomes the clock input and the A output is the data output. If the source position is the P1 position feedback interface, the data from the position feedback interface is transferred to the SSI output register once per sample period as defined by the *Encoder Simulation Sample Period (1x.087)*.

Figure 7-6 illustrates SSI data alignment

**Figure 7-6 SSI data alignment**

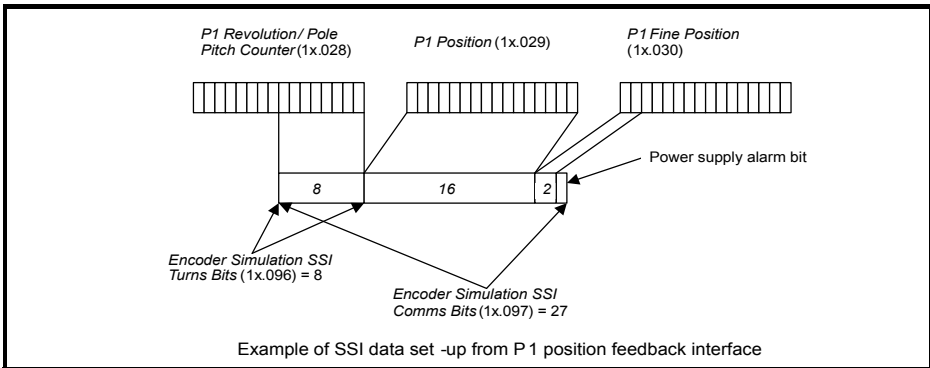

The SSI output is then clocked out from the register as shown in Figure 7-7.

**Figure 7-7 Example showing 15 data bits**

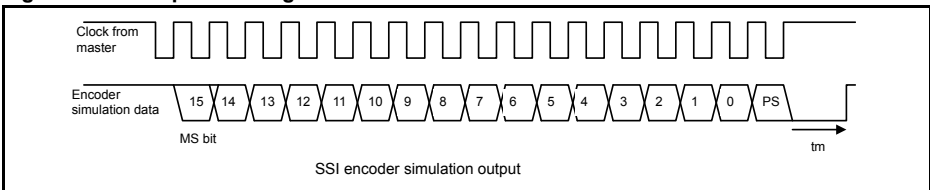

It should be noted that the data is shifted out by a clock that is produced by the SSI master connected to the encoder simulation interface as the interface is emulating an SSI encoder. However, unlike an SSI encoder the position data is not sampled on the first edge of the clock, but is updated by the drive at the rate defined by *Encoder Simulation Sample Period (1x.087)*. If the P1 position interface is being used as the source the power supply alarm bit (PS) is the inverse of the initialized flag in *Position Feedback Initialized (1x.076)* related to this interface. The master can clock out as many bits of data as required, but once the power supply alarm bit has been produced the output will remain low. The SSI interface reset time ( $t_m$ ) of 20  $\mu s$  is required so that the interface can detect the end of the transmission and reset itself so that the output data begins again at the most significant bit. During this period the master should hold the clock line high. The master should not use a clock frequency of less than 50 kHz or else spurious reset periods may be detected.

If any other parameter is used as the source the most significant M bits of the source parameter are used, where  $M = \text{Encoder Simulation SSI Comms Bits (1x.097)} - 1$ . If the source parameter has less than M bits then trailing zeros are added. The power supply alarm bit is always zero in this mode.

How to use this guide
Safety Information
Introduction
Mechanical Installation
Electrical Installation
Getting started
<b>Parameters</b>
Advanced operation
Diagnostics
Terminal data
Index

<b>1x.089</b>		<b>Encoder Simulation Hardware Divider</b>	
Minimum	0	Maximum	7
Default	0	Units	
Type	8 Bit User Save	Update Rate	Background read
Display Format	None	Decimal Places	0
Coding	RW		

If hardware mode is selected (i.e. *Encoder Simulation Mode (1x.088) = 0*) then *Encoder Simulation Hardware Divider (1x.089)* defines the divider ratio between the device connected to the P1 position feedback interface and the output as  $1/2 \text{ Encoder Simulation Hardware Divider (1x.089)}$ . The maximum allowed input frequency is 500 kHz, and so the maximum output frequency with the highest ratio of unity is 500 kHz.

<b>1x.089 value</b>	<b>Ratio</b>
0	1/1
1	1/2
2	1/4
3	1/8
4	1/16
5	1/32
6	1/64
7	1/128

**NOTE**

The scaling function provided by Pr **1x.089** is not available when Pr **1x.085 = 03.029**, see section 6.3 *Encoder Simulation Output Set-up* on page 43 for further details.

<b>1x.090</b>		<b>Encoder Simulation Hardware Marker Lock</b>	
Minimum	0	Maximum	1
Default	0	Units	
Type	8 Bit User Save	Update Rate	Background read
Display Format	None	Decimal Places	0
Coding	RW		

See *Encoder Simulation Mode (1x.088)*.

<b>1x.091</b>		<b>Encoder Simulation Incremental Mode Select</b>	
Minimum	0	Maximum	1
Default	0	Units	
Type	8 Bit User Save	Update Rate	Background read
Display Format	None	Decimal Places	0
Coding	RW		

See *Encoder Simulation Mode (1x.088)*.

<b>1x.092</b>		<b>Encoder Simulation Output Lines Per Revolution</b>	
Minimum	1	Maximum	16384
Default	4096	Units	
Type	32 Bit User Save	Update Rate	Background read
Display Format	None	Decimal Places	0
Coding	RW		

See *Encoder Simulation Mode (1x.088)*.

<b>1x.093</b>		<b>Encoder Simulation Numerator</b>	
Minimum	1	Maximum	65536
Default	65536	Units	
Type	32 Bit User Save	Update Rate	Background read
Display Format	None	Decimal Places	0
Coding	RW		

See *Encoder Simulation Mode (1x.088)*.

<b>1x.094</b>		<b>Encoder Simulation Denominator</b>	
Minimum	1	Maximum	65536
Default	65536	Units	
Type	32 Bit User Save	Update Rate	Background read
Display Format	None	Decimal Places	0
Coding	RW		

See *Encoder Simulation Mode (1x.088)*.

<b>1x.095</b>		<b>Encoder Simulation Output Roll-over Limit</b>	
Minimum	1	Maximum	65535
Default	65535	Units	
Type	16 Bit User Save	Update Rate	Background read
Display Format	None	Decimal Places	0
Coding	RW, BU		

See *Encoder Simulation Mode (1x.088)*.

<b>1x.096</b>		<b>Encoder Simulation SSI Turns Bits</b>	
Minimum	0	Maximum	16
Default	16	Units	
Type	8 Bit User Save	Update Rate	Background read
Display Format	None	Decimal Places	0
Coding	RW		

See *Encoder Simulation Mode (1x.088)*.

<b>1x.097</b>		<b>Encoder Simulation SSI Comms Bits</b>	
Minimum	2	Maximum	48
Default	33	Units	
Type	8 Bit User Save	Update Rate	Background read
Display Format	None	Decimal Places	0
Coding	RW		

See *Encoder Simulation Mode (1x.088)*.

<b>1x.098</b>		<b>Encoder Simulation Output Mode</b>	
Minimum	0	Maximum	2
Default	0	Units	
Type	8 Bit User Save	Update Rate	Background read
Display Format	None	Decimal Places	0
Coding	RW, Txt		

<b>Value</b>	<b>Text</b>
0	AB/Grey
1	FD/Binary
2	FR/Binary

*Encoder Simulation Output Mode (1x.098)* is used to select the format of the encoder simulation output as given in the table below.

<b>Encoder Simulation Mode (1x.088)</b>	<b>Encoder Simulation Output Mode (1x.098)</b>	<b>Format</b>
Hardware (0), Lines Per Rev (1), Ratio (2)	AB/Gray	AB quadrature signals
Hardware (0), Lines Per Rev (1), Ratio (2)	FD/Binary	Frequency and direction signals
Hardware (0), Lines Per Rev (1), Ratio (2)	FR/Binary	Forward and reverse signals
SSI (3)	AB/Gray	The position data is in Gray code format. This does not include the "power supply" bit if present.
SSI (3)	FD/Binary, FR/Binary	The position data is in binary format

FR encoder simulation output mode is not available if *Encoder Simulation Mode (1x.088)* is set to Hardware. FR encoder simulation output mode is available if *Encoder Simulation Mode (1x.088)* is set to *Lines Per Rev* or *Ratio*.

<b>1x.100</b>		<b>F1 Freeze Trigger Source</b>	
Minimum	1	Maximum	4
Default	1	Units	
Type	8 Bit User Save	Update Rate	Background read
Display Format	None	Decimal Places	0
Coding	RW, Txt		

Value	Text
1	24V Freeze Input
2	P1 Marker
3	P2 Marker
4	Common

*F1 Freeze Trigger Source (1x.100)* is used to select the source that generates trigger events for the F1 system.

#### 24V Freeze Input

The 24V Freeze Input (terminal 1 of the 10-way pluggable connector) on the module can be used as a trigger source.

#### 2, 3: Z1, Z2

Z1 selects the P1 position feedback interface marker input as the trigger source and Z2 selects the P2 position feedback interface marker input as the trigger source. No trigger events will be produced unless the selected maker input is available.

#### 4: Common

The output of the common freeze line is selected. The common freeze line can be controlled by the SI-Universal Encoder module, the drive or another option module.

<b>1x.101</b>		<b>F1 Freeze Mode</b>	
Minimum	0	Maximum	3
Default	0	Units	
Type	8 Bit User Save	Update Rate	Background read
Display Format	None	Decimal Places	0
Coding	RW, Txt		

Value	Text
0	Rising 1st
1	Falling 1st
2	Rising all
3	Falling all

#### 0: Rising 1st

Freeze events are produced on the rising edge of the freeze trigger source. If the *F1 Freeze Flag (1x.104)* is 0 then the first suitable edge produced by the trigger source causes the freeze position to be stored and the *F1 Freeze Flag (1x.104)* to be set to 1. No further freeze events are possible until the *F1 Freeze Flag (1x.104)* has been cleared by the user.

#### 1: Falling 1st

As for Rising 1st, but the falling edge is used to trigger freeze events.

## 2: Rising All

Freeze events are produced on the rising edge of the freeze trigger source. If the *F1 Freeze Flag (1x.104)* is 0 then the first suitable edge produced by the trigger source causes the freeze position to be stored and the *F1 Freeze Flag (1x.104)* to be set to 1. If further suitable edges are produced by the trigger source the freeze position is updated with the current position.

## 3: Falling All

As for Rising All but the falling edge is used to trigger freeze events.

Please refer to Figure 7-3 *P1 Freeze System* on page 54 for further information.

<b>1x.102</b>	<b>F1 Freeze Position Source</b>		
Minimum	0	Maximum	1
Default	0	Units	
Type	8 Bit User Save	Update Rate	Background read
Display Format	None	Decimal Places	0
Coding	RW, Txt		

<b>Value</b>	<b>Text</b>
0	P1
1	P2

*F1 Freeze Position Source (1x.102)* define the source position for the *F1 freeze system*. When a freeze event occurs, the position from the relevant position feedback interface including the effect of the marker (see *P1 Marker Mode (1x.031)* is stored and can be accessed as a 32 bit normalized value in *F1 Normalized Freeze Position (1x.103)*.

The freeze position is calculated as follows:

Digital incremental source: the position is captured in hardware and the normalized freeze position and freeze flag are updated by the drive within 250  $\mu$ s (the flag is always updated after the position is updated).

All other devices: The freeze position is the position at the 250  $\mu$ s sample point modified with time based interpolation based on the position change over the previous 250  $\mu$ s period.

<b>1x.103</b>	<b>F1 Normalized Freeze Position</b>		
Minimum	-2147483648	Maximum	2147483647
Default		Units	
Type	32 Bit Volatile	Update Rate	250 $\mu$ s write
Display Format	None	Decimal Places	0
Coding	RO, ND, NC, PT		

See *F1 Freeze Position Source (1x.102)*



<b>1x.104</b>		<b>F1 Freeze Flag</b>	
Minimum	0	Maximum	1
Default		Units	
Type	1 Bit Volatile	Update Rate	250 µs write
Display Format	None	Decimal Places	0
Coding	RW,ND, NC, PT		

The freeze flag is set when a freeze event occurs. If 0 is written to *F1 Freeze Flag (1x.104)* the freeze flag is cleared.

<b>1x.105</b>		<b>F1 Freeze Trigger Source</b>	
Minimum	1	Maximum	4
Default	1	Units	
Type	8 Bit User Save	Update Rate	Background read
Display Format	None	Decimal Places	0
Coding	RW, Txt		

Value	Text
1	24 V Freeze Input
2	P1 Marker
3	P2 Marker
4	Common

*F2 Freeze Trigger Source (1x.105)* is used to select the source that generates trigger events for the F2 freeze system.

#### 1: 24V Freeze Input

The 24V Freeze Input (terminal 1 of the 10-way pluggable connector) on the module can be used as a trigger source.

#### 2, 3: Z1, Z2

Z1 selects the P1 position feedback interface marker input as the trigger source and Z2 selects the P2 position feedback interface marker input as the trigger source. No trigger events will be produced unless the selected maker input is available.

#### 4: Common

The output of the common freeze line is selected. The common freeze line can be controlled by the SI-Universal Encoder module, the drive or another option module.

<b>1x.106</b>		<b>F2 Freeze Mode</b>	
Minimum	0	Maximum	3
Default	0	Units	
Type	8 Bit User Save	Update Rate	Background read
Display Format	None	Decimal Places	0
Coding	RW, Txt		

<b>Value</b>	<b>Text</b>
0	Rising 1st
1	Falling 1st
2	Rising all
3	Falling all

### **0: Rising 1st**

Freeze events are produced on the rising edge of the freeze trigger source. If the *F1 Freeze Flag* (1x.104) is 0 then the first suitable edge produced by the trigger source causes the freeze position to be stored and the *F1 Freeze Flag* (1x.104) to be set to 1. No further freeze events are possible until the *F2 Freeze Flag* (1x.109) has been cleared by the user.

### **1: Falling 1st**

As for Rising 1st, but the falling edge is used to trigger freeze events.

### **2: Rising All**

Freeze events are produced on the rising edge of the freeze trigger source. If the *F2 Freeze Flag* (1x.109) is 0 then the first suitable edge produced by the trigger source causes the freeze position to be stored and the *F2 Freeze Flag* (1x.109) to be set to 1. If further suitable edges are produced by the trigger source the freeze position is updated with the current position.

### **3: Falling All**

As for Rising All, but the falling edge is used to trigger freeze events.

Please refer to Figure 7-3 *P1 Freeze System* on page 54 for further information.

<b>1x.107</b>		<b>F2 Freeze Position Source</b>	
Minimum	0	Maximum	1
Default	0	Units	
Type	8 Bit User Save	Update Rate	Background read
Display Format	None	Decimal Places	0
Coding	RW, Txt		

<b>Value</b>	<b>Text</b>
0	P1
1	P2

*F2 Freeze Position Source* (1x.107) define the source position for the F2 freeze system. When a freeze event occurs, the position from the relevant position feedback interface including the effect of the marker (see *P1 Marker Mode* (1x.031) is stored and can be accessed as a 32 bit normalized value in *F2 Normalized Freeze Position* (1x.108). The position that is generated from a digital incremental source is captured in hardware and the normalized freeze position and freeze flag are updated by the drive within 250  $\mu$ s (the flag is always updated after the position is updated).

For all other types of source device some time based interpolation is required using the position

change over the previous 250  $\mu$ s period.

<b>1x.108</b>		<b>F2 Normalized Freeze Position</b>	
Minimum	-2147483648	Maximum	2147483647
Default		Units	
Type	32 Bit Volatile	Update Rate	250 $\mu$ s write
Display Format	None	Decimal Places	0
Coding	RO, ND, NC, PT		

See *F1 Normalized Freeze Position (1x.108)*.

<b>1x.109</b>		<b>F2 Freeze Flag</b>	
Minimum	0	Maximum	1
Default		Units	
Type	1 Bit Volatile	Update Rate	250 $\mu$ s write
Display Format	None	Decimal Places	0
Coding	RW, ND, NC, PT		

The freeze flag is set when a freeze event occurs. If 0 is written to *F2 Freeze Flag (1x.109)* the freeze flag is cleared.

<b>1x.110</b>		<b>Common Freeze Source 1</b>	
Minimum	1	Maximum	4
Default	1	Units	
Type	8 Bit User Save	Update Rate	Background read
Display Format	None	Decimal Places	0
Coding	RW, Txt		

Value	Text
1	24 V Freeze Input
2	P1 Marker
3	P2 Marker
4	Disabled

See *F1 Freeze Trigger Source (1x.100)* or *F2 Freeze Trigger Source (1x.105)*.

<b>1x.111</b>		<b>Common Freeze Source 2</b>	
Minimum	1	Maximum	4
Default	1	Units	
Type	8 Bit User Save	Update Rate	Background read
Display Format	None	Decimal Places	0
Coding	RW, Txt		

Value	Text
1	24 V Freeze Input
2	P1 Marker
3	P2 Marker
4	Disabled

How to use this guide
Safety Information
Introduction
Mechanical Installation
Electrical Installation
Getting started
<b>Parameters</b>
Advanced operation
Diagnostics
Terminal data
Index

See F1 Freeze Trigger Source (1x.100) or F2 Freeze Trigger Source (1x.105).

1x.112		Common Freeze Mode	
Minimum	0 (Display: 0000)	Maximum	15 (Display: 1111)
Default	0 (Display: 0000)	Units	
Type	8 Bit User Save	Update Rate	Background read
Display Format	Binary	Decimal Places	0
Coding	RW		

The common freeze system can be used to logically combine two freeze trigger sources. The switches in the common freeze system are controlled by the bits in *Common Freeze Mode (1x.112)* as defined in Table 7-7 *Common freeze mode* on page 100.

**Table 7-7 Common freeze mode**

Bit	Function
0	Source 1 input invert 1
1	Source 2 input invert
2	Output invert
3	Output enable

Therefore the value defined bits 2 to 0 can be used to generate various logic functions as given in the table below.

**Table 7-8 Logic functions**

Bits 2 to 0	Function
0	Source1 AND Source2
1	NOT(Source1) AND Source2
2	Source1 AND NOT(Source2)
3	Source1 NOR Source2
4	Source1 NAND Source2
5	NOT(Source1) NAND Source2
6	Source1 NAND NOT(Source2)
7	Source1 OR Source2

Please refer to Figure 7-3 *P1 Freeze System* on page 54 for further information.

1x.113		Freeze Input States	
Minimum	0 (Display: 00)	Maximum	3 (Display: 11)
Default		Units	
Type	8 Bit Volatile	Update Rate	4 ms write
Display Format	Binary	Decimal Places	0
Coding	RO, ND, NC, PT		

The bits in *Freeze Input States (1x.113)* show the level of the selected freeze inputs. Bit 0 corresponds to F1 freeze input and bit 1 corresponds to F2 freeze input.

1x.118	P1 Thermistor Type		
Minimum	0	Maximum	2
Default	0	Units	
Type	8 Bit User Save	Update Rate	Background read
Display Format	None	Decimal Places	0
Coding	RW, Txt		

*P1 Thermistor Type (1x.118)* defines the operating mode of the P1 thermistor input.

P1 Thermistor Type (1x.118)	Compatible devices
0: DIN44082	Three thermistors in series as specified in DIN44082 standard
1: KTY84	KTY84 PTC thermistor
2: 0.8 mA	Any device

If a device is connected between pin 15 of the encoder interface and 0V, a current source of 0.8 mA will pass through the device with a maximum voltage of approximately 3.8 V (i.e. maximum resistance of approximately 4750 Ω). The resistance of the device is calculated and displayed in *P1 Thermistor Feedback (1x.119)*. If *P1 Thermistor Type (1x.118)* is set to select KTY84, the temperature is also calculated and written to *P1 Thermistor Temperature (1x.122)*. Note that DIN44082 mode and 0.8 mA mode operate in exactly the same way.

1x.119	P1 Thermistor Feedback		
Minimum	0	Maximum	10000
Default		Units	Ω
Type	16 Bit Volatile	Update Rate	Background write
Display Format	None	Decimal Places	0
Coding	RO, ND, NC, PT		

See *P1 Thermistor Type (1x.118)*

1x.120	P1 Thermistor Trip Threshold		
Minimum	0	Maximum	10000
Default	3300	Units	Ω
Type	16 Bit User Save	Update Rate	Background read
Display Format	None	Decimal Places	0
Coding	RW		

See *P1 Thermistor Fault Detection (1x.123)*

1x.121	P1 Thermistor Reset Threshold		
Minimum	0	Maximum	10000
Default	1800	Units	Ω
Type	16 Bit User Save	Update Rate	Background read
Display Format	None	Decimal Places	0
Coding	RW		

See *P1 Thermistor Fault Detection (1x.123)*

<b>1x.122</b>		<b>P1 Thermistor Temperature</b>	
Minimum	-50	Maximum	300
Default		Units	°C
Type	16 Bit Volatile	Update Rate	Background write
Display Format	None	Decimal Places	0
Coding	RO, ND, NC, PT		

See *P1 Thermistor Type (1x.118)*

<b>1x.123</b>		<b>P1 Thermistor Fault Detection</b>	
Minimum	0	Maximum	2
Default	0	Units	
Type	8 Bit User Save	Update Rate	Background read
Display Format	None	Decimal Places	0
Coding	RW, Txt		

<b>Value</b>	<b>Text</b>
0	None
1	Temperature
2	Temp or Short

Defines the fault detection for the P1 thermistor input:

<b>P1 Thermistor Fault Detection (1x.123)</b>	<b>Fault detection</b>
0: None	No detection active
1: Temperature	Over temperature detection
2: Temp and Short	Over temperature and short circuit detection

If over temperature detection is enabled a *Motor Th trip* is initiated if *P1 Thermistor Feedback (1x.119)* is above the level defined by *P1 Thermistor Trip Threshold (1x.120)*. The trip cannot be reset until *P1 Thermistor Feedback (1x.119)* is below *P1 Thermistor Reset Threshold (1x.121)*.

If short circuit detection is enabled then a *Motor Th SC trip* is initiated if *P1 Thermistor Feedback (1x.119)* is below 50 Ω.

## 7.3 Menu 2x parameters for P2 interface

### 7.3.1 Menu 2x Single line parameter descriptions

Parameter	Range(↕)	Default(⇨)	Type						
			RO	Num	ND	NC	PT	FI	
<b>2x.027</b>	P2 Speed Feedback	-214748364.8 to 214748364.7 rpm		RO	Num	ND	NC	PT	FI
<b>2x.028</b>	P2 Revolution/ Pole Pitch Counter	0 to 65535		RO	Num	ND	NC	PT	
<b>2x.029</b>	P2 Position	0 to 65535		RO	Num	ND	NC	PT	
<b>2x.030</b>	P2 Fine Position	0 to 65535		RO	Num	ND	NC	PT	
<b>2x.031</b>	P2 Marker Mode	0000 to 1111	0100	RW	Bin				US
<b>2x.032</b>	P2 Marker Flag	Off (0) or On (1)	Off (0)	RW	Bit		NC		
<b>2x.033</b>	P2 Rotary Turns Bits	0 to 16	16	RW	Num				US
<b>2x.034</b>	P2 Rotary Lines Per Revolution	0 to 100000	4096	RW	Num				US
<b>2x.035</b>	P2 Comms Bits	0 to 48	0	RW	Num				US
<b>2x.037</b>	P2 Comms Baud Rate	100 k (0), 200 k (1), 300 k (2), 400 k (3), 500 k (4), 1 M (5), 1.5 M (6), 2 M (7), 4 M (8) Baud	300 k (2) Baud	RW	Txt				US
<b>2x.038</b>	P2 Device Type	None (0), AB (1), FD (2), FR (3), EnDat (4), SSI (5), BiSS* (6)	None (0)	RW	Txt				US
<b>2x.040</b>	P2 Error Detection Level	0000 to 1111	0001	RW	Bin				US
<b>2x.041</b>	P2 Auto- configuration Select	Disabled (0), Enabled (1)	Enabled (1)	RW	Txt				US
<b>2x.042</b>	P2 Feedback Filter	Disabled (0), 1 ms (1), 2 ms (2), 4 ms (3), 8 ms (4), 16 ms (5)	Disabled (0)	RW	Txt				US
<b>2x.043</b>	P2 Maximum Reference	0 to 50000	3000	RW	Num				US
<b>2x.044</b>	P2 Reference Scaling	0.000 to 4.000	1.000	RW	Num				US
<b>2x.045</b>	P2 Reference	±100.0 %		RO	Num	ND	NC	PT	FI
<b>2x.046</b>	P2 Reference Destination	0.000 to 59.999	0.000	RW	Num	DE		PT	US
<b>2x.047</b>	P2 SSI Incremental Mode	Off (0) or On (1)	Off (0)	RW	Bit				US
<b>2x.048</b>	P2 SSI Binary Mode	Off (0) or On (1)	Off (0)	RW	Bit				US
<b>2x.049</b>	P2 Additional Power- up Delay	0.0 to 25.0 s	0.0 s	RW	Num				US
<b>2x.050</b>	P2 Feedback Lock	Off (0) or On (1)	Off (0)	RW	Bit				US
<b>2x.051</b>	P2 Linear Feedback Select	Off (0) or On (1)	Off (0)	RW	Bit				US
<b>2x.052</b>	P2 Linear Comms Pitch	0.001 to 100.000	0.001	RW	Num				US
<b>2x.053</b>	P2 Linear Line Pitch	0.001 to 100.000	0.001	RW	Num				US
<b>2x.054</b>	P2 Linear Comms And Line Pitch Units	millimeters (0) and micrometers (1)	millimeters (0)	RW	Txt				US
<b>2x.055</b>	P2 Pole Pitch	0.01 to 1000.00	10.00 mm	RW	Num				US
<b>2x.056</b>	P2 Feedback Reverse	Off (0) or On (1)	Off (0)	RW	Bit				US

How to use this guide
Safety Information
Introduction
Mechanical Installation
Electrical Installation
Getting started
<b>Parameters</b>
Advanced operation
Diagnostics
Terminal data
Index

Parameter		Range(⊕)	Default(⇒)	Type					
2x.057	P2 Normalisation Turns	0 to 16	16	RW	Num				US
2x.058	P2 Normalisation Position	-2147483648 to 2147483647		RO	Num	ND	NC	PT	
2x.059	P2 Normalized Marker Position	-2147483648 to 2147483647		RO	Num	ND	NC	PT	
2x.060	P2 Calculation Time	0 to 20 μs	5 μs	RW	Num				US
2x.061	P2 Recovery Time	5 to 100 μs	30 μs	RW	Num				US
2x.062	P2 Line Delay Time	0 to 5000 ns	0 ns	RO	Num		NC	PT	US
2x.063	P2 Low Speed Update Rate Active	Off (0) or On (1)		RO	Bit	ND	NC	PT	
2x.064	P2 Encoder Protocol Detected	None (0), Hiperface (1), EnDat2.1 (2), EnDat2.2 (3), BiSS* (4)		RO	Txt	ND	NC	PT	
2x.067	P2 User Comms Enable	0 to 1	0	RW	Num		NC	PT	
2x.068	P2 User Comms Transmit Register	0 to 65535	0	RW	Num		NC	PT	
2x.069	P2 User Comms Receive Register	0 to 65535	0	RW	Num		NC	PT	
2x.071	P2 Error Detected	Off (0) or On (1)		RO	Bit	ND	NC	PT	
2x.072	P2 Status	None (0), AB (1), FD (2), FR (3), EnDat (4), SSI (5), BiSS* (6), EnDat Alt (7), SSI Alt (8), BiSS Alt* (9)		RO	Txt	ND	NC	PT	

RW	Read / Write	RO	Read-only	Bit	Bit parameter	Txt	Text string	Date	Date parameter	Time	Time parameter
Chr	Character parameter	Bin	Binary parameter	IP	IP address	Mac	MAC address	Ver	Version number	SMP	Slot, menu, parameter
Num	Number parameter	DE	Destination	ND	No default value	RA	Rating dependent	NC	Non-copyable	PT	Protected
Fl	Filtered	US	User save	PS	Power-down save						

\* BiSS is not currently supported.



## 7.3.2 P2 interface logic diagram

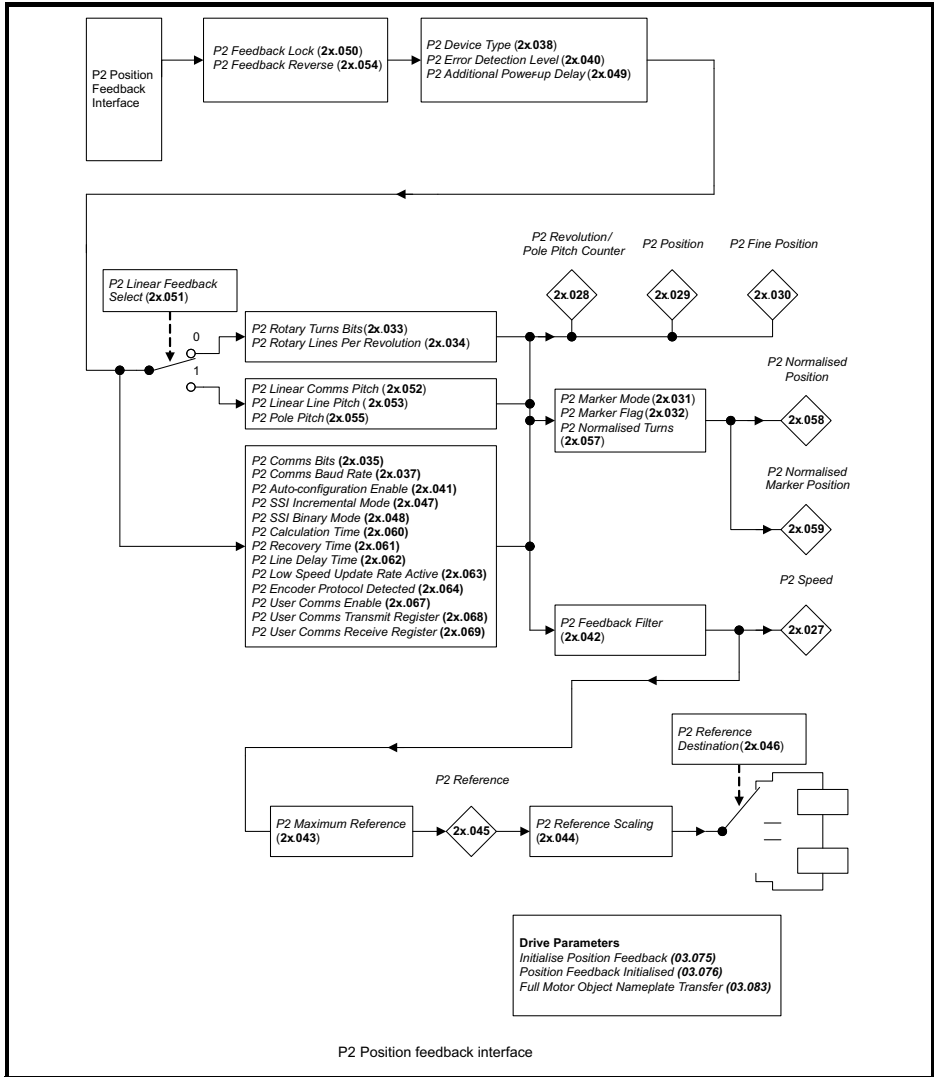

### 7.3.3 Menu 2x P2 Interface parameter descriptions

<b>2x.027</b>		<b>P2 Speed Feedback</b>	
Minimum	-214748364.8	Maximum	214748364.7
Default		Units	rpm
Type	32 Bit Volatile	Update Rate	4 ms write
Display Format	None	Decimal Places	1
Coding	RO, FI, ND, NC, PT		

Provided the set-up parameters for the position feedback device connected to the drive P2 position interface are correct *P2 Speed Feedback (2x.027)* shows the speed derived from the feedback. The speed is given in mm/s if *P2 Linear Feedback Select (2x.051)* = 1 and *Linear Speed Select (01.055)* on the drive = 1, otherwise it is given in rpm.

<b>2x.028</b>		<b>P2 Revolution/pole Pitch Counter</b>	
Minimum	0	Maximum	65535
Default		Units	
Type	16 Bit Volatile	Update Rate	4 ms write
Display Format	None	Decimal Places	0
Coding	RO, ND, NC, PT, BU		

*P2 Revolution/Pole Pitch Counter (2x.028)*, *P2 Position (2x.029)* and *P2 Fine Position (2x.030)* combined give the encoder position with a resolution of 1/232 of a revolution/pole pitch as a 48 bit number. If a rotary position feedback device is being used (*P2 Linear Feedback Select (2x.051)* = 0) then these quantities relate directly to the rotary position of the feedback device. If a linear feedback device is used then one revolution or pole pitch relates to the distance given by *P2 Pole Pitch (2x.055)*.

See *P1 Revolution/Pole Pitch Counter (1x.028)* for more information.

<b>2x.029</b>		<b>P2 Position</b>	
Minimum	0	Maximum	65535
Default		Units	
Type	16 Bit Volatile	Update Rate	4 ms write
Display Format	None	Decimal Places	0
Coding	RO, ND, NC, PT, BU		

See *P2 Revolution/Pole Pitch Counter (2x.028)*.

<b>2x.030</b>		<b>P2 Fine Position</b>	
Minimum	0	Maximum	65535
Default		Units	
Type	16 Bit Volatile	Update Rate	4 ms write
Display Format	None	Decimal Places	0
Coding	RO, ND, NC, PT, BU		

See *P2 Revolution/Pole Pitch Counter (2x.028)*.

2x.031	P2 Marker Mode		
Minimum	0 (Display: 0000)	Maximum	15 (Display: 1111)
Default	4 (Display: 0100)	Units	
Type	8 Bit User Save	Update Rate	Background read
Display Format	Binary	Decimal Places	0
Coding	RW		

**P2 Device type (2x.038) : AB, FD, FR**

Each position feedback device produces incremental signals which are counted in hardware. If *P2 Marker Mode (2x.031)* = 0 the following occurs when a marker event is produced by the Z1 input:

1. *P2 Position (2x.029)* and *P2 Fine Position (2x.030)* are reset to zero.
2. The bits in *P2 Normalized Position (2x.058)* related to *P2 Position (2x.029)* and *P2 Fine Position (2x.030)* are reset to zero
3. *P2 Marker Flag (2x.032)* is set to one.

The marker is a hardware function, and so the position appears as though it is reset at the marker event time even if this is between control system sample points. It should be noted that the marker event occurs on the rising edge of the marker pulse if the position change over the last sample was positive or on the falling edge if the position change over the last sample was negative. This ensures that the marker event occurs at the same physical location for either direction of rotation.

The action taken when a marker event occurs can be modified by setting the bits of *P2 Marker Mode (2x.031)* as described in the table below.

Bit	Effect of setting bit to one
0	No action is taken unless the marker flag is zero before the marker event occurs. <i>P2 Revolution/Pole Pitch Counter (2x.028)</i>
1	<i>P2 Revolution/Pole Pitch Counter (2x.028)</i> and the whole of <i>P2 Normalized Position (2x.058)</i> are also set to zero on a marker event
2	<i>P2 Revolution/Pole Pitch Counter (2x.028)</i> , <i>P2 Position (2x.029)</i> , <i>P2 Fine Position (2x.030)</i> and the related part of <i>P2 Normalized Position (2x.058)</i> are not reset. (This overrides bit 1.) <i>P2 Normalized Position (2x.058)</i> is transferred to <i>P2 Normalized Marker Position (2x.059)</i> and <i>P2 Marker Flag (2x.032)</i> is set to one.
3	This bit has no effect.

The marker input can be used for a standard type marker function or alternatively it can be used as an additional freeze input for the P1 position feedback interface.

**P2 Device type (2x.038): Any other device type**

The marker function cannot be used and *P2 Marker Mode (2x.031)* has no effect.

<b>2x.032</b>		<b>P2 Marker Flag</b>	
Minimum	0	Maximum	1
Default	0	Units	
Type	1 Bit Volatile	Update Rate	250 µs write
Display Format	None	Decimal Places	0
Coding	RW, NC		

*P2 Marker Flag (2x.032)* is set to one when a marker event occurs. The flag must be cleared by the user.

<b>2x.033</b>		<b>P2 Rotary Turns Bits</b>	
Minimum	0	Maximum	16
Default	16	Units	
Type	8 Bit User Save	Update Rate	Background read, auto-configuration write
Display Format	None	Decimal Places	0
Coding	RW		

*P2 Rotary Turns Bits (2x.033)* only has any effect if the position feedback interface is being used with a rotary device (i.e. *P2 Linear Feedback Select (2x.051)* = 0).

#### ***P2 Device type (2x.038) : EnDat, BiSS\*, SSI***

*P2 Rotary Turns Bits (2x.033)* is used to determine the number of bits within the comms messages from the position feedback device that represent turns. For a single turn encoder *P2 Rotary Turns Bits (2x.033)* must be set to zero. It should be noted that some SSI encoders include leading zeros before the turns information and in this case the number of turns bits should include the leading zeros. The most significant bits in *P2 Revolution/Pole Pitch Counter (2x.028)* that are not included in the turns information provided by the encoder comms are held at zero. If *P2 Rotary Turns Bits (2x.033)* = 0 (single turn encoder) the whole of *P2 Revolution/Pole Pitch Counter (2x.028)* is held at zero.

#### ***P2 Device type (2x.038): Any other device type***

It is sometimes desirable to mask off the most significant bits of *P2 Revolution/Pole Pitch Counter (2x.028)*, but this does not have to be done for the drive to function correctly. If *P2 Rotary Turns Bits (2x.033)* = 0 the whole of *P2 Revolution/Pole Pitch Counter (2x.028)* is held at zero. If *P2 Rotary Turns Bits (2x.033)* has any other value it indicates the number of bits in *P2 Revolution/Pole Pitch Counter (2x.028)* that are not held at zero. For example, if *P2 Rotary Turns Bits (2x.033)* = 5, then *P2 Revolution/Pole Pitch Counter (2x.028)* counts up to 31 before being reset.

\* BiSS is not currently supported.

<b>2x.034</b>		<b>P2 Rotary Lines Per Revolution</b>	
Minimum	0	Maximum	100000
Default	4096	Units	
Type	32 Bit User Save	Update Rate	Background read, auto-configuration write
Display Format	None	Decimal Places	0
Coding	RW		

*P2 Rotary Lines Per Revolution (2x.034)* only has any effect if the position feedback interface is being used with a rotary device (i.e. *P2 Linear Feedback Select (2x.051)* = 0).

**P2 Device type (2x.038): AB**

*P2 Rotary Lines Per Revolution (2x.034)* should be set to the number of lines per revolution for the encoder connected to the P1 position feedback interface.

**P2 Device type (2x.038): FD, FR**

*P2 Rotary Lines Per Revolution (2x.034)* should be set to the number of lines per revolution for the encoder connected to the P1 position feedback interface multiplied by 2.

**P2 Device type (2x.038) : Any other device type**

*P2 Rotary Lines Per Revolution (2x.034)* has no effect.

<b>2x.035</b>		<b>P2 Comms Bits</b>	
Minimum	0	Maximum	48
Default	0	Units	
Type	8 Bit User Save	Update Rate	Background read, auto-configuration write
Display Format	None	Decimal Places	0
Coding	RW		

**P2 Device type (2x.038): EnDat, SSI, BiSS\***

*P2 Comms Bits (2x.035)* should be set to the total number of bits of position information in the comms message from the encoder. If SSI communications is being used this should include any leading or trailing zeros and the power supply alarm bit if present.

**P2 Device type (2x.038) : Any other device type**

*P2 Comms Bits (2x.035)* has no effect.

\* BiSS is not currently supported.

<b>2x.037</b>		<b>P2 Comms Baud Rate</b>	
Minimum	0	Maximum	8
Default	2	Units	Baud
Type	8 Bit User Save	Update Rate	Background read, auto-configuration write
Display Format	None	Decimal Places	0
Coding	RW, Txt		

<b>Value</b>	<b>Text</b>
0	100 k
1	200 k
2	300 k
3	400 k
4	500 k
5	1 M
6	1.5 M
7	2 M
8	4 M

*P2 Comms Baud Rate (2x.037)* defines the baud rate used for encoder communications. Restrictions are applied to the baud rate for different feedback devices, and so the baud rate may be different to the parameter value.

***P2 Device type (2x.038) : EnDat, BiSS\*, SSI***

Any baud rate that is within the range specified for the encoder may be used. The line delay is measured during Initialization, and used to compensate this delay during communications with the encoder. Therefore there is no timing based restriction on the length of the cable between the position feedback interface and the encoder. However, care should be taken to ensure that the wiring arrangement and the type of cable used are suitable for the selected baud rate and the distance between the position interface and the encoder. See *P2 Low Speed Update Rate Active (2x.063)* for more details on timing restrictions related to the drive sample times.

***P2 Device type (2x.038) : Any other device***

*P2 Comms Baud Rate (2x.037)* has no effect.

\* BiSS is not currently supported.

<b>2x.038</b>		<b>P2 Device Type</b>	
Minimum	0	Maximum	6
Default	0	Units	
Type	8 Bit User Save	Update Rate	Background read
Display Format	None	Decimal Places	0
Coding	RW, Txt		

<b>Value</b>	<b>Text</b>
0	None
1	AB
2	FD
3	FR
4	EnDat
5	SSI
6	BiSS*

If *P2 Device type (2x.038)* = None, the P2 position feedback interface is disabled and does not provide any position feedback.

See *P1 Device Type (1x.038)* for more information on the different position feedback device types.

<b>2x.040</b>		<b>P2 Error Detection Level</b>	
Minimum	0 (Display: 0000)	Maximum	15 (Display: 1111)
Default	1 (Display: 0001)	Units	
Type	8 Bit User Save	Update Rate	Background read
Display Format	Binary	Decimal Places	0
Coding	RW		

This parameter can be used to enable or disable position feedback trip functions as follows:

<b>Bit</b>	<b>Function</b>
0	Not used with the P2 position interface
1	Not used with the P2 position interface
2	Enable SSI power supply alarm bit monitor
3	Disable trips Wire Break to CRC Error
4	Disable <i>Setup Changed P2</i> trip

If *P2 Error Detection Level (2x.040)* bit 3 is set the position feedback device will still become autoinitialized when the trip condition occurs, but it will not cause a trip to be initiated and it will not prevent the drive from being enabled.

\* BiSS is not currently supported.

## Encoder trips

The following table shows trips that can be initiated that are related to the position feedback interface.

Drive trip	Encoders	Reason for error
* <i>Comms Timeout P2</i>	EnDat, BiSS***	Comms timeout
* <i>CRC Error P2</i>	EnDat, BiSS***	Checksum/CRC error
	SSI	Not ready at start of position transfer (i.e. data input not one)
* <i>SSI Error P2</i>	EnDat, BiSS***	The encoder has indicated an error
	SSI	+ Power supply alarm bit active
<i>Comms Timeout P2</i>	EnDat, SSI, BiSS***	<i>P2 Device type (2x.038)</i> , <i>P2 Comms Bits (2x.035)</i> , <i>P2 Comms Baud Rate (2x.037)</i> , <i>P2 Calculation Time (2x.060)</i> , <i>P2 Recovery Time (2x.061)</i> , <i>P2 Line Delay Time (2x.062)</i> and <i>P2 User Comms Enable (2x.067)</i> are used to determine the time taken for the communications exchange with the encoder. If this time exceeds 250 µs a <i>Comms Timeout P2</i> trip is initiated.
<i>Encoder Type P2</i>	BiSS***	The encoder could not be identified during auto-configuration
** <i>Setup Changed P2</i>	All	A set-up parameter for the device has been changed.

+ These trips can be enabled or disabled with *P2 Error Detection Level (2x.040)* bit 2.

\* These trips can be enabled or disabled with *P2 Error Detection Level (2x.040)* bit 3.

\*\* This trip can be enabled or disabled with *P2 Error Detection Level (2x.040)* bit 4.

\*\*\* BiSS is not currently supported.

## Wire-break detection

It may be important to detect a break in the connections between the drive and the position feedback device. This feature is provided for most position feedback devices either directly or indirectly as shown in Table 7-9 on page 112.

**Table 7-9 Wire-Break Detection**

Device	Detection method	Trip produced
AB, FD, FR	There is no wire break detection of the A2, B2, and Z2 signals on the P2 position interface.	None
EnDat, BiSS*	Wire break in the comms link is detected by a CRC or timeout error.	Comms Timeout
SSI	Wire break detection in the comms is difficult with these devices. However, if power supply alarm bit monitoring is enabled the drive will be looking for a one at the start of the message and a zero to indicate that the power supply is okay. If the clock stops or the data line is disconnected the data input to the drive may stay in one state or the other and cause a trip.	SSI Power Trip

\* BiSS is not currently supported.



## Setup Changed P2 trips

If P2 Error Detection Level (**2x.040**) bit 4 is set then:

- The drive will not trip if any of the setup parameters are changed whilst the drive is in the Inhibit or Ready state. The encoder will be automatically re-configured with the new setting (no reset required).
- The drive will trip if any of the setup parameters are changed whilst running.
- The Setup Changed P2 trip suppression is only active with AB, FD, FR type encoders, all other encoders will trip the drive if one of the setup parameters has changed whether the drive is running or disabled.

<b>2x.041</b>	<b>P2 Auto Configuration Select</b>		
Minimum	0	Maximum	1
Default	1	Units	
Type	8 Bit User Save	Update Rate	Background read
Display Format	None	Decimal Places	0
Coding	RW, Txt		

Value	Text
0	Disabled
1	Enabled

### **P2 Device type (2x.038) : EnDat, BiSS\***

If auto-configuration has not been disabled (i.e. *P2 Auto-configuration Select (2x.041) = 0*) then during position feedback Initialization, the encoder is interrogated to determine whether the encoder is a rotary or linear encoder and *P2 Linear Feedback Select (2x.051)* is set up appropriately. The following parameters are then set-up based on information from the encoder:

Rotary	Linear
<i>P2 Rotary Turns Bits (2x.033)</i>	<i>P2 Linear Comms Pitch (2x.052)</i>
<i>P2 Rotary Lines Per Revolution (2x.034)</i>	<i>P2 Linear Line Pitch (2x.053)</i>
<i>P2 Comms Bits (2x.035)</i>	<i>P2 Comms Bits (2x.035)</i>
	<i>P2 Linear Comms And Line Pitch Units (2x.054)</i>

The following actions are also taken to set up the timing for the encoder.

Comms Protocol	Actions taken
EnDat 2.1	<i>P2 Calculation Time (2x.060)</i> = From the encoder <i>P2 Recovery Time (2x.061)</i> = 30 $\mu$ s Line delay measured and result written to <i>P2 Line Delay Time (2x.062)</i>
EnDat 2.2	<i>P2 Calculation Time (2x.060)</i> = From the encoder <i>P2 Recovery Time (2x.061)</i> = 4 $\mu$ s and the recovery time within the encoder is set up to the shortest value of 3.75 $\mu$ s if the <i>P2 Comms Baud Rate (2x.037)</i> is 1M or more. Line delay measured and result written to <i>P2 Line Delay Time (2x.062)</i>
BiSS*	<i>P2 Recovery Time (2x.061)</i> = 12 $\mu$ s Line delay measured and result written to <i>P2 Line Delay Time (2x.062)</i>
SSI	Line delay measured and result written to <i>P2 Line Delay Time (2x.062)</i>

\* BiSS is not currently supported.

If *P2 Auto-configuration Select (2x.041)* = 1 then *P2 Comms Baud Rate (2x.037)* is set to the minimum value that will give a total message transfer time of less than 62  $\mu$ s, so that the transfer will occur at the fast update rate with the minimum baud rate. It should be noted that the value of *P2 User Comms Enable (2x.067)* is taken into account as this may affect the message time.

Once these parameters have been set up it should be possible for the drive to operate correctly with the encoder. The drive repeatedly attempts to initialize the encoder, including auto-configuration which is part of this process, until it is successful.

Therefore if auto-configuration has not been successful by the time the drive is enabled because the drive cannot establish communications, an Encoder Setup Changed trip occurs.

For BiSS\* encoders the drive must identify the encoder model number to perform auto-configuration. If communications is established, but the drive cannot recognise the encoder model an Encoder Type Not Recognized trip is produced immediately.

If auto-configuration is disabled (i.e. *P2 Auto-configuration Select (2x.041)* = 1) then none of the above actions are carried out except for the line delay measurement.

**P2 Device type (2x.038): All other device types**

*P2 Auto-configuration Select (2x.041)* has no effect.

<b>2x.042</b>		<b>P2 Feedback Filter</b>	
Minimum	0	Maximum	5
Default	0	Units	
Type	8 Bit User Save	Update Rate	Background read
Display Format	None	Decimal Places	0
Coding	RW, Txt		

Value	Text
0	Disabled
1	1 ms
2	2 ms
3	4 ms
4	8 ms
5	16 ms

*P2 Feedback Filter (2x.042)* defines the time period for a sliding window filter that may be applied to the feedback taken from the drive P2 position feedback interface. This is particularly useful in applications where the drive encoder is used to give speed feedback for the speed controller, and where the load includes high inertia and subsequently the speed controller gains are very high. Under these conditions without a filter on the feedback, it is possible for the speed loop output to change constantly from one current limit to the other and lock the integral term of the speed controller.

\* BiSS is not currently supported.

2x.043	P2 Maximum Reference		
Minimum	0	Maximum	50000
Default	3000	Units	
Type	16 Bit User Save	Update Rate	Background read
Display Format	None	Decimal Places	0
Coding	RW, BU		

The speed feedback from the P2 position feedback interface can be used as a source to control a parameter.

The speed feedback is scaled to give a value as a percentage of *P2 Maximum Reference (2x.043)* in 0.1% units which is displayed in *P2 Reference (2x.043)*.

The value is then scaled by *P2 Reference Scaling (2x.044)*, and then routed to the destination defined by *P2 Reference Destination (2x.046)*.

Normally the destination is updated every 4 ms, but if the destination is the *Hard Speed Reference (03.022)* on the drive, *P2 Maximum Reference (2x.043)* = VM\_SPEED\_FREQ\_REF[MAX] and *P2 Reference Scaling (2x.044)* = 1.000 it is updated every 250 μs. Although the hard speed reference is updated every 250 μs internally, a value in rpm or mm/s is written to the *Hard Speed Reference (03.022)* every 4 ms for indication only.

The value transferred to the hard speed reference is written in internal speed units as a change of position in  $1/2^{32}$  revolution units over a time period of 250 μs giving a speed resolution of  $55.9 \times 10^6$  rpm.

2x.044	P2 Reference Scaling		
Minimum	0.000	Maximum	4.000
Default	1.000	Units	
Type	16 Bit User Save	Update Rate	Background read
Display Format	None	Decimal Places	3
Coding	RW		

See *P2 Maximum Reference (2x.043)*.

2x.045	P2 Reference		
Minimum	-100.0	Maximum	100.0
Default		Units	%
Type	16 Bit Volatile	Update Rate	4 ms write
Display Format	None	Decimal Places	1
Coding	RO, FI, ND, NC, PT		

See *P2 Maximum Reference (2x.043)*.

2x.046	P2 Reference Destination		
Minimum	0.000	Maximum	59.999
Default	0.000	Units	
Type	16 Bit User Save	Update Rate	Drive Reset Read
Display Format	None	Decimal Places	3
Coding	RW, DE, PT, BU		

See *P2 Maximum Reference (2x.043)*.

<b>2x.047</b>		<b>P2 SSI Incremental Mode</b>	
Minimum	0	Maximum	1
Default	0	Units	
Type	16 Bit User Save	Update Rate	Background read
Display Format	None	Decimal Places	0
Coding	RW		

**P2 Device type (2x.038): SSI**

If *P2 SSI Incremental Mode (2x.047)* = 0 the complete absolute position is read at each sample.

Care should be taken when using this mode as some unwanted effects can occur when the encoder passes through the boundary between its maximum position and zero.

When in this mode, the encoder can be used for motor control provided at least 6 bits of turns information are provided by the encoder otherwise an over speed trip will be produced as the position passes over the maximum position to zero boundary. *P2 Normalized Position (2x.058)* can be used for position control over this boundary provided the normalized turns bits are set up so that the normalized positions do not contain turns information that is not available from the encoder. As the SSI format does not include any error checking, it is not possible to detect if the position data has been corrupted by noise.

The benefit of using the absolute position directly from an SSI encoder, is that even if the encoder communications are disturbed by noise and position errors occur, the position will always recover the correct position after the disturbance has ended.

If *P2 SSI Incremental Mode (2x.047)* = 1 the absolute position is only taken from the encoder during Initialization. The change of position over each sample is then accumulated to determine the position. This method always gives 16 bits of turns information that can always be used without jumps in position whatever value is used as the turns bits for normalization. If noise corrupts the data from an SSI encoder, it is possible to have an apparently large change in position which can result in the turns information becoming and remaining, corrupted until the encoder is re-initialized.

If an SSI encoder is used but is not powered from the drive, and the encoder is powered up after the drive, it is possible that the first change of position detected could be large enough to cause the problems described above. This can be avoided if the encoder interface is initialized with *Initialise Position Feedback (1x.075)* after the encoder has powered up.

If the encoder includes a power supply alarm bit, the power supply monitor should be enabled. This will ensure that the drive remains tripped until the encoder is powered up and the action of resetting the trip will re initialize the encoder interface.

**P2 Device type (2x.038): All other device types**

*P2 SSI Incremental Mode (2x.047)* has no effect.

<b>2x.048</b>		<b>P2 SSI Incremental Mode</b>	
Minimum	0	Maximum	1
Default	0	Units	
Type	1 Bit User Save	Update Rate	Background read
Display Format	None	Decimal Places	0
Coding	RW		

**P2 Device type (2x.038) : SSI**

SSI encoders normally use Gray code data format. However, some encoders use binary format which may be selected by setting *P2 SSI Binary Mode (2x.048)* to one.

**P2 Device type (2x.038) : All other device types**

*P2 SSI Binary Mode (2x.048)* has no effect.

<b>2x.049</b>		<b>P2 Additional Power-up Display</b>	
Minimum	0.0	Maximum	25.0
Default	0.0	Units	s
Type	8 Bit User Save	Update Rate	Background read
Display Format	None	Decimal Places	1
Coding	RW, BU		

When the position feedback is initialized at power-up or at any other time, a delay is included before the information from the feedback device is used or any attempt made to communicate with the device. *P2 Additional Power-up Delay (2x.049)* defines an additional delay that is added to the minimum delay. See *P1 Additional Power-up Delay (1x.049)* for the minimum delays for the different position feedback device types.

<b>2x.050</b>		<b>P2 Feedback Lock</b>	
Minimum	0	Maximum	1
Default	0	Units	
Type	1 Bit User Save	Update Rate	Background read
Display Format	None	Decimal Places	0
Coding	RW		

If *P2 Feedback Lock (2x.050)* = 1 then *P2 Revolution/Pole Pitch Counter (2x.028)*, *P2 Position (2x.029)* and *P2 Fine Position (2x.030)* are not updated. If *P2 Feedback Lock (2x.050)* = 0 then these parameters are updated normally.

<b>2x.051</b>		<b>P2 Linear Feedback Select</b>	
Minimum	0	Maximum	1
Default	0	Units	
Type	1 Bit User Save	Update Rate	Background read, auto-configuration write
Display Format	None	Decimal Places	0
Coding	RW		

If *P2 Linear Feedback Select (2x.051)* = 0 then the drive P1 position feedback interface is configured to operate with a rotary position feedback device. *P2 Rotary Turns Bits (2x.033)* and *P2*

*Rotary Lines Per Revolution (2x.034)* should be used to set up the position feedback interface.

If *P2 Linear Feedback Select (2x.051)* = 1 then the position feedback interface is configured to operate with a linear position feedback device. *P2 Linear Comms Pitch (2x.052)* and *P2 Linear Line Pitch (2x.053)* should be used to set up the position feedback interface.

<b>2x.052</b>	<b>P2 Linear Comms Pitch</b>		
Minimum	0.001	Maximum	100.000
Default	0.001	Units	
Type	32 Bit User Save	Update Rate	Background read, auto-configuration write
Display Format	None	Decimal Places	3
Coding	RW		

**P2 Device type (2x.038) : EnDat, SSI, BiSS\***

*P2 Linear Comms Pitch (2x.052)* is used to define the distance covered by the least significant bit of the position information in a comms message from a linear encoder. The units used by this parameter are defined by *P2 Linear Comms And Line Pitch Units (2x.054)*.

**P2 Device type (2x.038): Any other device**

*P2 Linear Comms Pitch (2x.052)* has no effect.

<b>2x.053</b>	<b>P2 Linear Line Pitch</b>		
Minimum	0.001	Maximum	100.000
Default	0.001	Units	
Type	32 Bit User Save	Update Rate	Background read, auto-configuration write
Display Format	None	Decimal Places	3
Coding	RW		

*P2 Linear Line Pitch (2x.053)* only has any effect if the position feedback interface is being used with a linear device (i.e. *P2 Linear Feedback Select (2x.051)* = 1) and should be used to define the distances listed below for each type of device. The units used by this parameter are defined by *P2 Linear Comms And Line Pitch Units (2x.054)*.

**P2 Device type (2x.038): AB**

*P2 Linear Line Pitch (2x.053)* should be set to the distance covered by one line period on the encoder.

**P2 Device type (2x.038): FD, FR**

*P2 Linear Line Pitch (2x.053)* should be set to the distance covered by two line periods on the encoder.

**P2 Device type (2x.038): Any other device**

*P2 Linear Line Pitch (2x.053)* has no effect.

\* BiSS is not currently supported.

<b>2x.054</b>		<b>P2 Linear Comms And Line Pitch Units</b>	
Minimum	0	Maximum	1
Default	0	Units	
Type	8 Bit User Save	Update Rate	Background read
Display Format	None	Decimal Places	0
Coding	RW, Txt		

<b>Value</b>	<b>Text</b>
0	millimeters
1	micro metres

*P2 Linear Comms And Line Pitch Units (2x.054)* defines the units used by *P2 Linear Comms Pitch (2x.052)* and *P2 Linear Line Pitch (2x.053)* in millimeters or micrometres.

<b>2x.055</b>		<b>P2 Pole Pitch</b>	
Minimum	0.01	Maximum	1000.00
Default	10.00	Units	mm
Type	32 Bit User Save	Update Rate	Background read
Display Format	None	Decimal Places	2
Coding	RW		

*P2 Pole Pitch (2x.055)* is used to define the distance equivalent to one pole for linear position feedback devices. If the linear position feedback device is being used with a linear motor, then *P2 Pole Pitch (2x.055)* should be set to the pole pitch of the motor.

<b>2x.056</b>		<b>P2 Feedback Reverse</b>	
Minimum	0	Maximum	1
Default	0	Units	
Type	1 Bit User Save	Update Rate	Background read
Display Format	None	Decimal Places	0
Coding	RW		

If *P2 Feedback Reverse (2x.056)* = 1 the position feedback is negated. This can be used to reverse the direction of the position feedback.

<b>2x.057</b>		<b>P2 Normalization Turns</b>	
Minimum	0	Maximum	16
Default	16	Units	
Type	8 Bit User Save	Update Rate	Background read
Display Format	None	Decimal Places	0
Coding	RW		

*P2 Normalization Turns (2x.057)* defines the number of turns bits included in the following parameters. See *P2 Normalization Turns (2x.057)* for more information.

*P2 Normalized Position (2x.058)*

*P2 Normalized Marker Position (2x.059)*

*F1 Normalized Freeze Position (1x.103)* if P2 is the source position for freeze function F1

*P2 Normalized Freeze Position (1x.108)* if P2 is the source position for freeze function F2

<b>2x.058</b>		<b>P2 Normalized Position</b>	
Minimum	-2147483648	Maximum	2147433647
Default		Units	
Type	32 Bit Volatile	Update Rate	250 µs write
Display Format	None	Decimal Places	0
Coding	RO, ND, NC, PT		

*P2 Normalized Position (2x.058)* is the position taken from the position feedback device including the effect of the marker function. See *P2 Normalization Turns (2x.057)* for details of the format.

<b>2x.059</b>		<b>P2 Normalized Marker Position</b>	
Minimum	-2147483648	Maximum	2147433647
Default		Units	
Type	32 Bit Volatile	Update Rate	250 µs write
Display Format	None	Decimal Places	0
Coding	RO, ND, NC, PT		

*P2 Normalized Marker Position (2x.059)* is the value *P2 Normalized Position (2x.058)* at the last marker event provided bit 2 of *P2 Marker Mode (2x.031)* is set to 1. See *P2 Marker Mode (2x.031)* for more details.

<b>2x.060</b>		<b>P2 Calculation Time</b>	
Minimum	0	Maximum	20
Default	5	Units	µs
Type	8 Bit User Save	Update Rate	Background read, auto-configuration write
Display Format	None	Decimal Places	0
Coding	RW		

***P2 Device type (2x.038): EnDat***

*P2 Calculation Time (2x.060)* is the time from the first edge of the clock signal from the position feedback interface until the encoder has calculated the position and is ready to return this information. This is used to calculate the overall time for a message interchange with the encoder. See *P2 Low Speed Update Rate Active (2x.063)* for more details.

***P2 Device type (2x.038): Any other type of device***

*P2 Calculation Time (2x.060)* has no effect.

<b>2x.061</b>		<b>P2 Recovery Time</b>	
Minimum	5	Maximum	100
Default	30	Units	µs
Type	8 Bit User Save	Update Rate	Background read, auto-configuration write
Display Format	None	Decimal Places	0
Coding	RW		



**P2 Device type (2x.038): EnDat, SSI, BiSS\***

*P2 Recovery Time (2x.061)* is the time that must be allowed after each message interchange before a new message begins.

**P2 Device type (2x.038): Any other type of device**

*P2 Recovery Time (2x.061)* has no effect.

<b>2x.062</b>	<b>P2 Line Delay Time</b>		
Minimum	0	Maximum	5000
Default	0	Units	ns
Type	16 Bit User Save	Update Rate	Background read, position feedback initialization write
Display Format	None	Decimal Places	0
Coding	RO, NC, PT		

**P2 Device type (2x.038): EnDat, SSI, BiSS\***

During position feedback Initialization, the transmission delay between the position feedback interface and the encoder and back again is measured and stored in *P2 Line Delay Time (2x.062)*. This value is then used to compensate for this delay so that the clock/data skew does not prevent the data from the encoder from being read.

This means that longer line lengths can be used with these feedback devices provided the correct cable and connection arrangements are used.

**P2 Device type (2x.038): Any other type of device**

*P2 Line Delay Time (2x.062)* is always zero.

<b>2x.063</b>	<b>P2 Low Speed Update Rate Active</b>		
Minimum	0	Maximum	1
Default		Units	
Type	1 Bit Volatile	Update Rate	Background write
Display Format	None	Decimal Places	0
Coding	RO, ND, NC, PT		

**P2 Device type (2x.038): EnDat, SSI, BiSS\***

If the position can be sampled in 60  $\mu$ s, *P2 Low Speed Update Rate Active (2x.063)* = 0, otherwise *P2 Low Speed Update Rate Active (2x.063)* = 1.

The following parameters are used by the drive to determine the time required to obtain the data from the position feedback device:

*P2 Rotary Turns Bits (2x.033)*

*P2 Comms Bits (2x.035)*

*P2 Comms Baud Rate (2x.037)*

*P2 Calculation Time (2x.060)*

*P2 Recovery Time (2x.061)*

*P2 Line Delay Time (2x.062)*

*P2 User Comms Enable (2x.067)*

See *P1 Low Speed Update Rate Active (1x.063)* for more information on how this time is calculated.

\* BiSS is not currently supported.

How to use this guide
Safety Information
Introduction
Mechanical Installation
Electrical Installation
Getting started
<b>Parameters</b>
Advanced operation
Diagnostics
Terminal data
Index

**P2 Device type (2x.038): Any other type of device**

P2 Low Speed Update Rate Active (2x.063) is always zero.

<b>2x.064</b>		<b>P2 Encoder Protocol Detected</b>	
Minimum	0	Maximum	4
Default		Units	
Type	8 Bit Volatile	Update Rate	Background write
Display Format	None	Decimal Places	0
Coding	RO, Txt, ND, NC, PT		

<b>Value</b>	<b>Text</b>
0	None
1	Hiperface
2	EnDat2.1
3	EnDat2.2
4	BiSS

P2 Encoder Protocol Detected (2x.064) shows the encoder comms protocol detected during position feedback Initialization. If P2 Device type (2x.038) is set to BiSS\* then P2 Encoder Protocol Detected (2x.064) is set to the appropriate value after successful communication with the encoder during initialization.

If P2 Device type (2x.038) is set to EnDat then P2 Encoder Protocol Detected (2x.064) is set to the appropriate EnDat protocol after successful communication with the encoder during Initialization. If communications are not successful during Initialization then P2 Encoder Protocol Detected (2x.064) is set to 0 (None).

<b>2x.067</b>		<b>P2 User Comms Enable</b>	
Minimum	0	Maximum	1
Default	0	Units	
Type	8 Bit Volatile	Update Rate	Background read
Display Format	None	Decimal Places	0
Coding	RW, NC, PT		

If P2 User Comms Enable (2x.067) set to a non-zero value it is possible to use P2 User Comms Transmit Register (2x.068) and P2 User Comms Receive Register (2x.069) to communicate with an encoder that has a Hiperface, EnDat 2.1, EnDat2.2 or BiSS\* interface. See P1 User Comms Enable (1x.067) for a description of how to use these registers.

<b>2x.068</b>		<b>P2 User Comms Transmit Register</b>	
Minimum	0	Maximum	65535
Default	0	Units	
Type	16 Bit Volatile	Update Rate	Background read/write
Display Format	None	Decimal Places	0
Coding	RW, NC, PT, BU		

See P2 User Comms Enable (2x.067).

\* BiSS is not currently supported.

<b>2x.069</b>		<b>P2 User Comms Receive Register</b>	
Minimum	0	Maximum	65535
Default	0	Units	
Type	16 Bit Volatile	Update Rate	Background read/write
Display Format	None	Decimal Places	0
Coding	RW, NC, PT, BU		

See *P2 User Comms Enable (2x.067)*.

<b>2x.071</b>		<b>P2 Error Detected</b>	
Minimum	0	Maximum	1
Default	0	Units	
Type	1 Bit Volatile	Update Rate	Background Write
Display Format	None	Decimal Places	0
Coding	RO, ND, NC, PT		

*P2 Error Detected (2x.071)* is set if an error has been detected with the position feedback device connected to the P2 position interface. This parameter is useful if encoder trips have been disabled with *P2 Error Detection Level (2x.040)*.

<b>2x.072</b>		<b>P2 Status</b>	
Minimum	0	Maximum	9
Default		Units	
Type	8 Bit Volatile	Update Rate	Background Write
Display Format	None	Decimal Places	0
Coding	RO, Txt, ND, NC, PT		

Value	Text
0	None
1	AB
2	FD
3	FR
4	EnDat
5	SSI
6	BiSS*
7	EnDat Alt
8	SSI Alt
9	BiSS* Alt

\* BiSS is not currently supported.

Priority of the 15-way D-type is assigned in the following order from the highest priority to the lowest.

1. P1 position interface
2. Encoder simulation output
3. P2 position interface

The availability of the P2 position interface on the 15-way D-type on the drive is dependent on type of feedback device selected in *P1 Device Type (1x.038)* and the encoder simulation mode selected

in *Encoder Simulation Mode (1x.088)*. *P2 Status (2x.072)* shows the status of the P2 position interface depending on the settings in *P2 Device type (2x.038)*, *P1 Device Type (1x.038)*, and *Encoder Simulation Mode (1x.088)*.

**0: None**

The P2 position interface is not available.

- 1. : AB
- 2. : FD
- 3. : FR
- 4. : EnDat
- 5. : SSI
- 6. : BiSS\*

The P2 position interface is available. The connections for the P2 position interface are shown in Table 7-10 on page 124.

**Table 7-10 P2 Position Interface Connections**

<i>P2 Status (2x.072)</i>	15-way D-type connections					
	1/2	3/4	5/6	7/8	9/10	11/12
AB				A2	B2	Z2
FD				F2	D2	Z2
FR				F2	R2	Z2
EnDat				D2	Clk2	Z2
SSI				D2	Clk2	Z2
BiSS*				D2	Clk2	Z2

**7: EnDat Alt**

**8: SSI Alt**

**9: BiSS\* Alt**

The P2 position interface is available but uses alternative connections as shown below as connection 7/8 and 9/10 are used by the encoder simulation output.

<i>P2 Status (2x.072)</i>	15-way D-type connections					
	1/2	3/4	5/6	7/8	9/10	11/12
EnDat Alt			D2	AOut	BOut	Clk2
SSI Alt			D2	AOut	BOut	Clk2
BiSS* Alt			D2	AOut	BOut	Clk2

\* BiSS is not currently supported.

# 8 Advanced operation

## 8.1 Encoder communications

A communication channel is provided to allow the user to communicate with an encoder connected to one of the communications interfaces (this feature is enabled using **1x.067** or **2x.067**). During auto-configuration of the position feedback device or during the transfer of electronic nameplate data, the communications channel will be disabled.

To send a message to the encoder the required message must be written to the transmit register (**1x.068** or **2x.068**). To read the response from the encoder, the data is read from the receive register (**1x.069** or **2x.069**). The data is written one byte at a time and then stored in a 16 byte buffer before being sent to the encoder. The data should only be written to the transmit register when it has been cleared to zero by the drive. Bits 13 to 15 are used to control the interface.

Bit	1x.068 or 2x.068 Function
15	This bit should be set to one each time data is written to the transmit register. This indicates that data has been written. This bit will be cleared when the LS byte of the data has been transferred into the comms buffer.
14	This bit should be set when the last byte of the message is written to the transmit register. The data will be read and transferred to the comms buffer and then the message will be sent to the encoder.
13	This bit should be set when the first byte of the message is written to the transmit register. Setting this bit will reset the pointer to the start of the comms buffer.

Data can be read from the receive register at any time. If there is data in the buffer, bit 15 will be set. Once the data has been read the register should be cleared and the drive will transfer the next byte of data to the register.

Bit	1x.069 or 2x.069 Function
15	Indicates that data from the last transfer can be read from the receive register.
14	Indicates that the last byte from the receive message is in the register.
13	There is no data in the receive buffer and the LS byte of the receive register is the comms system status. If there was an error in the received message this will always be set and one of the status error bits will be set until the comms is used again by this system or by the drive.

The status flags are defined as follows:

Bit	1x.069 or 2x.069 Function
0	The number of bytes put into the transmit buffer is not consistent with the expected message length. (Hiperface only).
1	The number of bytes written to the transmit buffer, or the expected length of the store data transmit message, or the expected length of a read data message have exceed the length of the buffer. (Hiperface only)
2	The command code is not supported.
3	A valid response was not received from the encoder.

How to use  
this guide

Safety  
Information

Introduction

Mechanical  
Installation

Electrical  
Installation

Getting started

Parameters

Advanced  
operation

Diagnostics

Terminal data

Index

## Hiperface

Up to 15 bytes of data can be written to the buffer. The first byte should be the encoder address. The checksum will be calculated by the drive and added to the end of the message before the message is transmitted to the encoder. The drive checks the checksum of the received message.

If successfully received, the receive message can be read via the receive register including the address and the checksum received from the encoder. It should be noted that the encoder must be set up for 9600 baud, 1 start bit, 1 stop bit and even parity (default set-up) for the encoder comms to operate with the drive. Also the data block security should not be enabled in the encoder if the drive encoder nameplate system is to operate correctly. See the Hiperface specification for details of the comms message format.

The following commands are supported:

Code	Command
0x42	Read position
0x43	Set position
0x44	Read analog value
0x46	Read counter
0x47	Increment counter
0x49	Clear counter
0x4a	Read data (maximum of 10 bytes)
0x4b	Store data (maximum of 9 bytes)
0x4c	Data field status
0x4d	Create a data field
0x4e	Available memory
0x50	Read encoder status
0x52	Read type
0x53	Reset encoder

## SC EnDat

Up to 4 bytes can be written to the buffer in the following format:

Byte 0			
Command	Address	Data (MSB)	Data (LSB)

The following commands are supported:

Code	Command	Address	Data (MSB)	Data (LSB)
0x07	Encoder to send position value	Any	Any	Any
0x0E	Selection of memory area	MRS code	Any	Any
0x1C	Encoder to receive parameter	Address	Data (MSB)	Data (LSB)
0x23	Encoder to send parameter	Address	Any	Any
0x2A	Encoder to receive reset	Any	Any	Any

The message from the encoder contains a CRC which is checked. If there are no errors in the message the message is put into the comms buffer. If the position is requested it is shifted into the buffer locations from the right as shown below. The message shown contains the maximum number of bits (48).

If less position data is available the result, including the error bit, is shifted right accordingly and the leading bits are set to zero.

Byte 0							Byte 7
Bits 63-56	Bits 55-48	Bits 47-40	Bits 39-32	Bits 31-24	Bits 23-16	Bits 15-8	Bits 7-0

Bit0 is the error bit from the encoder and the least significant bit of the position is in bit 1, etc. Leading zeros are present beyond the most significant bit of the position value from the encoder. If any other command is sent the response is as shown below.

Byte 0		
Address	Data (MSB)	Data (LSB)

### EnDat

Up to 4 bytes can be written to the buffer in the same format as for EnDat 2.1. The following commands are supported:

Code	Command	Address	Data (MSB)	Data (LSB)
0x09	Encoder to send position value with additional information and select memory area	MRS code	0x00	Block address
0x1B	Encoder to send position value with additional information and receive parameters	Address	Data (MSB)	Data (LSB)
0x24	Encoder to send position value with additional information and send parameters	Address	Any	Any
0x2D	Encoder to send position value with additional information and receive error reset	Any	Any	Any

The message from the encoder contains a CRC which is checked. If there are no errors in the message the message is transferred to the comms buffer.

Byte 0					Byte 5
First additional information received (B7) WRN (B6) RM (B5) Busy (B4) I4 (B3) I3 (B2) I2 (B1) I1 (B0) I0	First additional information received Byte 1	First additional information received Byte 2	Second additional information received (B7) WRN (B6) RM (B5) Busy (B4) I4 (B3) I3 (B2) I2 (B1) I1 (B0) I0	Second additional information received Byte 1	Second additional information received Byte 2

If two additional items of information are used, the first one received is additional information 2. The drive uses the relevant MRS code to enable the transmission of the required additional information without content. Other MRS codes can be used to select the content for each additional item of information, but the MRS codes to select additional information which are not currently selected, or to de-select additional information must not be used.

### BISS\* / SC BISS\*

Encoder user BISS communications is not supported with these encoder types.

\* BISS is not currently supported.

---

# 9 Diagnostics

---

## 9.1 Overview

This section provides basic diagnostic information intended to resolve the most common problems encountered when setting up an SI-Universal Encoder option module.

### 9.1.1 Drive trip display codes

If the option module detects an error during operation, it will force a trip on the drive. The exact reason for the trip will be logged in the drive trip log (Pr **10.020** to Pr **10.029**).

Table 9-1 shows the possible trips that will be displayed on the drive when a problem is detected with the option module or when the option module initiates a trip.

**Table 9-1 Drive trip display codes**

Trip	Description
SlotX HF	The drive has detected that an option module is present but is unable to communicate with it due to a hardware fault.
SlotX Error	User trip generated by the option module
SlotX Not Fitted	This trip will occur if a drive slot was previously configured with an option module but on power up, no option module was detected.
SlotX Different	This trip will occur if a drive slot was previously configured with an option module but on power up, a different option module was detected. Replacing the option module with another one of the same ID number will not initiate this trip. The trip will also occur if an option module is installed to a previously un-used slot.



### 9.1.2 Encoder error codes

If the option module detects an Encoder error during operation, it will force a trip on the drive and provide a sub-trip string for a clearer definition of the trip. The sub-trip is shown in drive Pr **10.070** to Pr **10.079**. Table 9-2 shows all possible encoder error codes.

**Table 9-2 Encoder error codes**

Value	Text	Description
100	Enc PS Overload	Encoder power supply output overload
101	Wire break P1	General wire break on P1 interface
102	Wire break P2	General wire break on P2 interface
103	Wire break A P1	Wire break A on P1 interface
104	Wire break B P1	Wire break B on P1 interface
105	Wire break Z P1	Wire break Z on P1 interface
106	UVW phase P1	UVW phase error on P1 interface
107	UVW phase P2	UVW phase error on P2 interface
108	Comms timeout P1	Comms timeout on P1 interface
109	Comms timeout P2	Comms timeout on P2 interface
110	CRC error P1	CRC error on P1 interface
111	CRC error P2	CRC error on P2 interface
112	SSI error P1	SSI signal or power supply error on P1 interface
113	SSI error P2	SSI signal or power supply error on P2 interface
114	Setup changed P1	Configuration of P1 interface has changed
115	Setup changed P2	Configuration of P2 interface has changed
116	Comms period P1	Comms exceeded 250 $\mu$ s on P1 interface
117	Comms period P2	Comms exceeded 250 $\mu$ s on P2 interface
118	Phase offset P1	Phase offset angle incorrect on P1 interface
119	Encoder type P1	Unrecognized encoder type on P1 interface
120	Encoder type P2	Unrecognized encoder type on P2 interface
121	Rotary LPR P1	Rotary lines per revolution error on P1 interface
122	Comms pitch P1	Linear comms pitch error on P1 interface
123	Line pitch P1	Linear line pitch error on P1 interface
124	Turns bits P1	Rotary turns bits error on P1 interface
125	Comms bits P1	Comms bits error on P1 interface
126	Calc time P1	Calculation time too long on P1 interface
127	Line delay P1	Line delay measured longer than 5 $\mu$ s on P1 interface
128	Rotary LPR P2	Rotary lines per revolution error on P2 interface
129	Comms pitch P2	Linear comms pitch error on P2 interface
130	Line pitch P2	Linear line pitch error on P2 interface
131	Turns bits P2	Rotary turns bits error on P2 interface
132	Comms bits P2	Comms bits error on P2 interface
133	Calc time P2	Calculation time too long on P2 interface
134	Line delay P2	Line delay measured longer than 5 $\mu$ s on P2 interface
135	General trip	Undocumented catch-all trip
136	Motor Th	Motor thermistor too hot
137	Motor Th SC	Motor thermistor short circuit

How to use this guide
Safety information
Introduction
Mechanical Installation
Electrical Installation
Getting started
Parameters
Advanced operation
<b>Diagnostics</b>
Terminal data
Index

### 9.1.3 Module error codes

If the option module detects an Encoder error during operation, it will force a trip on the drive and provide a sub-trip string for a clearer definition of the trip. The sub-trip is shown in drive Pr **10.070** to Pr **10.079**. Table 9-3 below shows all possible encoder error codes.

**Table 9-3 Module error codes**

Value	Text	Description
200	FW Invalid	
201	Drv unknown	
202	Drv unsupported	
203	Mode unknown	
204	Mode unsupported	
205	OHT	
206	Res	
207	Res	
208	Res	
209	Res	
210	Res	
211	Res	
212	Factory Settings	Missing Factory Settings
213	Power Supply	Power Supply Fault
214	PCB TH Error	The power up system test found that the pcb thermistor is outside of maximum range
215	ASIC Error	The power up system test found that digital ASIC interface is not operational
216	EEPROM Error	The power up system test found that EEPROM interface is not operational
217	Param Error	Parameter value transfer between module and drive failed
218	Watchdog Error	The processor watchdog has detected an error
219	Res	
220	Res	
221	Res	
222	Res	
223	Res	
224	Res	
225	Res	
226	Exception	Processor Exception

# 10 Terminal data

## 10.1 15 Way D-type connectors

<b>1</b>	<b>A,F, Cosref, Data</b>
<b>2</b>	<b>A\,F\ Cosref\, Data\</b>
<b>AB (0), FD (1), FR (2), AB Servo (3), FD Servo(4), FR Servo (5)</b>	
Type	EIA 485 differential receivers
Maximum input frequency	500 kHz
Line loading	< 2 unit loads
Line termination components	120 Ω (switchable)
Working common mode range	-7 V to +12 V
<b>SC Hiperface (7), SC EnDat (9), SC SSI (11), SC Servo (12)</b>	
Type	Differential voltage
Maximum Signal level	1.25 V peak to peak (sin with regard to sinref and cos with regard to cosref)
Maximum input frequency	See Table 3-2 <i>Interpolated information based on frequency and voltage level</i> on page 13.
Maximum applied differential voltage and common mode voltage range	±4 V
<b>Resolution:</b> The sine wave frequency can be up to 500 kHz but the resolution is reduced at high frequency. Table 3-2 <i>Interpolated information based on frequency and voltage level</i> on page 13 shows the number of bits of interpolated information at different frequencies and with different voltage levels at the drive encoder port.	
<b>EnDat (8), SSI (10), BISS (13)*</b>	
Type	EIA 485 differential receivers
Maximum input frequency	4 MHz
Working common mode range	-7 V to +12 V
<b>Common to All</b>	
Absolute maximum applied voltage relative to 0V	-9 V to 14 V

\* BISS is not currently supported.

How to use  
this guide

Safety  
Information

Introduction

Mechanical  
Installation

Electrical  
Installation

Getting started

Parameters

Advanced  
operation

Diagnostics

**Terminal data**

Index

<b>3</b>	<b>B, D, R Sinref, Clock</b>
<b>4</b>	<b>B<sub>1</sub>, D<sub>1</sub>, R<sub>1</sub>, Sinref<sub>1</sub>, Clock<sub>1</sub></b>
<b>AB (0), FD (1), FR (2), AB Servo (3), FD Servo(4), FR Servo (5)</b>	
Type	EIA 485 differential receivers
Maximum input frequency	500 kHz
Line loading	< 2 unit loads
Line termination components	120 Ω (switchable)
Working common mode range	-7 V to +12 V
<b>SC Hiperface (7), SC EnDat (9), SC SSI (11), SC Servo (12)</b>	
Type	Differential voltage
Maximum Signal level	1.25 V peak to peak (sin with regard to sinref and cos with regard to cosref)
Maximum input frequency	See Table 3-2 <i>Interpolated information based on frequency and voltage level</i> on page 13.
Maximum applied differential voltage and common mode voltage range	±4 V
<b>Resolution:</b> The sine wave frequency can be up to 500 kHz but the resolution is reduced at high frequency. Table 3-2 <i>Interpolated information based on frequency and voltage level</i> on page 13 shows the number of bits of interpolated information at different frequencies and with different voltage levels at the drive encoder port	
<b>EnDat (8), SSI (10), BISS (13)*</b>	
Type	EIA 485 differential receivers
Maximum input frequency	4 MHz
Working common mode range	-7 V to +12 V
<b>Common to All</b>	
Absolute maximum applied voltage relative to 0V	-9 V to 14 V

\* BISS is not currently supported.

<b>5</b>	<b>Z, Data, Freeze</b>
<b>6</b>	<b>ZI, DataI, FreezeI</b>
<b>AB (0), FD (1), FR (2), AB Servo (3), FD Servo(4), FR Servo (5)</b>	
Type	EIA 485 differential receivers
Maximum input frequency	512 kHz
Line loading	< 2 unit loads
Line termination components	120 Ω (switchable)
Working common mode range	-7 V to +12 V
<b>SC Hiperface (7), SC EnDat (9), SC SSI (11), SC Servo (12)</b>	
Type	EIA 485 differential receivers
Maximum input frequency	4 MHz
Working common mode range	-7 V to +12 V
<b>Resolution:</b> The sine wave frequency can be up to 500 kHz but the resolution is reduced at high frequency. Table 3-2 <i>Interpolated information based on frequency and voltage level</i> on page 13 shows the number of bits of interpolated information at different frequencies and with different voltage levels at the drive encoder port.	
<b>EnDat (8), SSI (10), BiSS (13)*</b>	
Type	EIA 485 differential receivers
Maximum input frequency	4 MHz
Line termination components	120 Ω (switchable)
Working common mode range	-7 V to +12 V
<b>Common to All</b>	
Absolute maximum applied voltage relative to 0V	-9 V to 14 V

<b>7</b>	<b>U,</b>
<b>8</b>	<b>U\</b>
<b>AB Servo (3), FD Servo(4), FR Servo (5), SC Servo (12)</b>	
Type	EIA 485 differential receivers
Maximum input frequency	512 kHz
Line loading	1 unit load
Line termination components	120 Ω (fixed)
Working common mode range	-7 V to +12 V
<b>Common to All</b>	
Absolute maximum applied voltage relative to 0V	-9 V to 14 V

\* BiSS is not currently supported.

<b>9</b>	<b>V</b>
<b>10</b>	<b>V<sub>I</sub></b>
<b>AB Servo (3), FD Servo(4), FR Servo (5), SC Servo (12)</b>	
Type	EIA 485 differential receivers
Maximum input frequency	512 kHz
Line loading	1 unit load
Line termination components	120 Ω (Fixed)
Working common mode range	-7 V to +12 V
<b>Common to All</b>	
Absolute maximum applied voltage relative to 0V	-9 V to 14 V

<b>11</b>	<b>W, Clock</b>
<b>12</b>	<b>W<sub>I</sub>, Clock<sub>I</sub></b>
<b>AB Servo (3), FD Servo(4), FR Servo (5), SC Servo (12)</b>	
Type	EIA 485 differential receivers
Maximum input frequency	512 kHz
Line loading	1 unit load
Line termination components	120 Ω (Fixed)
Working common mode range	-7 V to +12 V
<b>SC EnDat (9), SC SSI (11)</b>	
Type	EIA 485 differential receivers
Maximum input frequency	4 MHz
Working common mode range	-7 V to +12 V
<b>Common to All</b>	
Absolute maximum applied voltage relative to 0V	-9 V to +14 V

**Common to all feedback types**

<b>13</b>	<b>Feedback device supply</b>
Supply voltage	5.15 V ±2 %, 8 V ± 5 % or 15 V ± 5 %
Maximum output current	300 mA for 5 V and 8 V 200 mA for 15 V
The voltage on Terminal 13 is controlled by Pr <b>1x.036</b> . The default for this parameter is 5 V (0) but this can be set to 8 V (1) or 15 V (2). Setting the encoder voltage too high for the encoder could result in damage to the feedback device. The termination resistors should be disabled if the outputs from the encoder are higher than 5 V.	

<b>14</b>	<b>0V Common</b>
-----------	------------------

<b>15</b>	<b>Motor thermistor input</b>
Thermistor type is selected in <i>P1 Thermistor Type</i> ( <b>1x.118</b> ).	

## 10.2 10-Way pluggable connections

<b>1</b>	<b>+24 V Freeze Input</b>
Type	EIA 485 differential receivers
Voltage range	0V to +24 V
Absolute Maximum applied voltage range	-3 V to +30 V
Impedance	>2 mA @15 V from IEC 61131-2, type 1, 6.6 k $\Omega$
Input thresholds	10 V $\pm$ 0.8 V from IEC 61131-2, type 1

<b>2</b>	<b>0V Common</b>
----------	------------------

<b>3</b>	<b>A, F, Data</b>
<b>4</b>	<b>A1, F1, Data1</b>
<b>5</b>	<b>B, D, R Clock</b>
<b>6</b>	<b>B1, D1, R1, Clock1</b>
<b>8</b>	<b>Z, Freeze2</b>
<b>9</b>	<b>Z1, Freeze21</b>

<b>AB, FD, FR</b>	
Type	EIA 485 differential receivers
Maximum input frequency	512 kHz
Line termination components	120 $\Omega$ (Fixed)
Working common mode range	-7 V to +12 V
<b>EnDat, SSI, BiSS*</b>	
Type	EIA 485 differential receivers
Maximum signal level	1.25 V peak to peak (sin with regard to sinref and cos with regard to cosref)
Maximum input frequency	4 MHz
Line termination components	120 $\Omega$ (Fixed)
Working common mode range	-7 V to +12 V
<b>Common to All</b>	
Absolute maximum applied voltage relative to 0V	-9 V to 14 V

\* BiSS is not currently supported.

<b>7</b>	<b>0V Common</b>
----------	------------------

<b>10</b>	<b>Feedback device supply</b>
Supply voltage	5.15 V $\pm$ 2 %, 8 V $\pm$ 5 % or 15 V $\pm$ 5 %
Maximum output current	300 mA for 5 V and 8 V, 200 mA for 15 V
The voltage on Terminal 10 is controlled by Pr <b>xx.036</b> . The default for this parameter is 5 V (0) but this can be set to 8 V (1) or 15 V (2). Setting the encoder voltage too high for the encoder could result in damage to the feedback device. The termination resistors should be disabled if the outputs from the encoder are higher than 5 V.	

Please refer to section 5.1.2 *Terminal descriptions* on page 29 for further terminal information.

---

# Index

---

<b>A</b>	
Absolute encoders .....	19
Available resolution .....	24
<b>C</b>	
Cable requirements .....	33
Cautions .....	7
Commutation signals .....	14
Compatibility with encoder types .....	11
<b>D</b>	
Diagnostics .....	128
<b>E</b>	
Electrical noise .....	35
Electrical safety .....	7
Encoder circuit with galvanic isolation from encoder body .....	31
Encoder selection .....	19
Encoder Simulation Output .....	43
Encoder with galvanic isolation from motor .....	30
<b>F</b>	
Features .....	10
Feedback cable .....	33, 35
Feedback cable connections .....	34
Freeze System .....	47
<b>H</b>	
High resolution feedback .....	20
<b>I</b>	
Incremental plus commutation .....	14
Installation .....	35
<b>N</b>	
No isolation .....	32, 33
Non absolute encoders .....	19
Notes .....	7
<b>P</b>	
P1 position interface .....	35
P2 position interface .....	40
Power cables .....	33
<b>S</b>	
Setting up a feedback device .....	35
Set-up parameters .....	10
Shield connections .....	33



<b>T</b>	
Terminal data .....	131
Terminal descriptions .....	25
Termination resistors .....	46
<b>W</b>	
Warnings .....	7
Wiring connections .....	35

How to use this  
guide

Safety  
Information

Introduction

Mechanical  
Installation

Electrical  
Installation

Getting started

Parameters

Diagnostics

Terminal data

**Index**



**0478-0214-03**