



**CONTROL  
TECHNIQUES**

www.controltechniques.com



*User Guide*

# **Unidrive**

*Model sizes 1 to 9*

Universal Variable Speed AC  
Drive for induction and servo  
motors

Part Number: 0471-0000-11

Issue: 11

## General Information

The manufacturer accepts no liability for any consequences resulting from inappropriate, negligent or incorrect installation or adjustment of the optional operating parameters of the equipment or from mismatching the variable speed drive with the motor.

The contents of this guide are believed to be correct at the time of printing. In the interests of a commitment to a policy of continuous development and improvement, the manufacturer reserves the right to change the specification of the product or its performance, or the contents of the guide, without notice.

All rights reserved. No parts of this guide may be reproduced or transmitted in any form or by any means, electrical or mechanical including photocopying, recording or by an information storage or retrieval system, without permission in writing from the publisher.

## Drive software version

This product is supplied with the latest version of software. If this product is to be used in a new or existing system with other drives, there may be some differences between their software and the software in this product. These differences may cause this product to function differently. This may also apply to drives returned from a Control Techniques Service Centre.

The software version of the drive can be checked by looking at Pr **11.29** (or Pr **0.50**) and Pr **11.34**. The software version takes the form of zz.yy.xx, where Pr **11.29** displays zz.yy and Pr **11.34** displays xx, i.e. for software version 01.01.00, Pr **11.29** would display 1.01 and Pr **11.34** would display 0.

If there is any doubt, contact a Control Techniques Drive Centre.

## Environmental statement

Control Techniques is committed to minimising the environmental impacts of its manufacturing operations and of its products throughout their life cycle. To this end, we operate an Environmental Management System (EMS) which is certified to the International Standard ISO 14001. Further information on the EMS, our Environmental Policy and other relevant information is available on request, or can be found at [www.greendrives.com](http://www.greendrives.com).

The electronic variable-speed drives manufactured by Control Techniques have the potential to save energy and (through increased machine/process efficiency) reduce raw material consumption and scrap throughout their long working lifetime. In typical applications, these positive environmental effects far outweigh the negative impacts of product manufacture and end-of-life disposal.

Nevertheless, when the products eventually reach the end of their useful life, they can very easily be dismantled into their major component parts for efficient recycling. Many parts snap together and can be separated without the use of tools, while other parts are secured with conventional screws. Virtually all parts of the product are suitable for recycling.

Product packaging is of good quality and can be re-used. Large products are packed in wooden crates, while smaller products come in strong cardboard cartons which themselves have a high recycled fibre content. If not re-used, these containers can be recycled. Polythene, used on the protective film and bags for wrapping product, can be recycled in the same way. Control Techniques' packaging strategy favours easily-recyclable materials of low environmental impact, and regular reviews identify opportunities for improvement.

When preparing to recycle or dispose of any product or packaging, please observe local legislation and best practice.

Copyright © October 2005 Control Techniques Drives Limited

Issue Number: 11

Software: 01.08.01 onwards

# How to use this guide

This user guide provides complete information for installing and operating a Unidrive SP from start to finish. The information is in logical order, taking the reader from receiving the drive through to fine tuning the performance.

## NOTE

There are specific safety warnings throughout this guide, located in the relevant sections. In addition, Chapter 1 *Safety Information* contains general safety information. It is essential that the warnings are observed and the information considered when working with or designing a system using the drive.

This map of the user guide helps to find the right sections for the task you wish to complete:

|                           | Quick Start / bench testing | Familiarisation | System design | Programming and commissioning | Troubleshooting |
|---------------------------|-----------------------------|-----------------|---------------|-------------------------------|-----------------|
| 1 Safety information      | ●                           | ●               | ●             | ●                             | ●               |
| 2 Product information     |                             | ●               | ●             |                               |                 |
| 3 Mechanical installation |                             |                 | ●             |                               |                 |
| 4 Electrical installation |                             |                 | ●             |                               |                 |
| 5 Getting started         |                             | ●               | ●             |                               |                 |
| 6 Basic parameters        |                             | ●               | ●             | ●                             |                 |
| 7 Running the motor       | ●                           | ●               | ●             | ●                             |                 |
| 8 Optimisation            |                             |                 | ●             | ●                             |                 |
| 9 SMARTCARD operation     |                             |                 | ●             | ●                             |                 |
| 10 Onboard PLC            |                             |                 | ●             | ●                             |                 |
| 11 Advanced parameters    |                             |                 | ●             | ●                             |                 |
| 12 Technical data         |                             | ●               | ●             | ●                             |                 |
| 13 Diagnostics            |                             |                 |               |                               | ●               |
| 14 UL listing information |                             |                 | ●             | ●                             |                 |

# Contents

|  |          |   |            |
|--|----------|---|------------|
| <b>Declaration of Conformity (Size 1 to 3) .. 6</b>  | <b>4</b> | <b>Electrical Installation .....</b>  | <b>66</b>  |
| <b>Declaration of Conformity (Size 4 and 5) 7</b>    | 4.1      | Power connections .....   | 66         |
| <b>Declaration of Conformity (Size 6) .....</b>      | 4.2      | AC supply requirements .....  | 72         |
| <b>Declaration of Conformity (Size 8 and 9) 9</b>    | 4.3      | Supplying the drive with DC / DC bus paralleling                                      | 73         |
| <b>1 Safety Information .....</b>                    | 4.4      | Heatsink fan supply .....   | 73         |
| 1.1 Warnings, Cautions and Notes .....               | 4.5      | Control 24Vdc supply .....  | 74         |
| 1.2 Electrical safety - general warning .....        | 4.6      | Low voltage DC power supply .....   | 74         |
| 1.3 System design and safety of personnel .....      | 4.7      | Ratings .....   | 75         |
| 1.4 Environmental limits .....                       | 4.8      | Output circuit and motor protection .....   | 78         |
| 1.5 Compliance with regulations .....                | 4.9      | Braking .....   | 80         |
| 1.6 Motor .....                                      | 4.10     | Ground leakage .....  | 82         |
| 1.7 Adjusting parameters .....                       | 4.11     | EMC (Electromagnetic compatibility) .....   | 82         |
| <b>2 Product Information .....</b>                   | 4.12     | Serial communications connections .....   | 91         |
| 2.1 Ratings .....                                    | 4.13     | Control connections .....   | 92         |
| 2.2 Model number .....                               | 4.14     | Encoder connections .....   | 96         |
| 2.3 Operating modes .....                            | 4.15     | Low voltage DC mode enable and heatsink fan<br>supply connections (size 4 to 6) ..... | 99         |
| 2.4 Compatible encoders .....                        | 4.16     | SECURE DISABLE .....  | 100        |
| 2.5 Drive features .....                             | <b>5</b> | <b>Getting Started.....</b>   | <b>102</b> |
| 2.6 Nameplate description .....                      | 5.1      | Understanding the display .....   | 102        |
| 2.7 Options .....                                    | 5.2      | Keypad operation .....  | 102        |
| 2.8 Items supplied with the drive .....              | 5.3      | Menu structure .....  | 103        |
| <b>3 Mechanical Installation .....</b>               | 5.4      | Menu 0 .....  | 104        |
| 3.1 Safety information .....                         | 5.5      | Advanced menus .....  | 104        |
| 3.2 Planning the installation .....                  | 5.6      | Changing the operating mode .....   | 106        |
| 3.3 Terminal cover removal .....                     | 5.7      | Saving parameters .....   | 106        |
| 3.4 Baying free standing cubicles .....              | 5.8      | Restoring parameter defaults .....  | 106        |
| 3.5 Solutions Module fitting / removal .....         | 5.9      | Parameter access level and security .....   | 106        |
| 3.6 Mounting methods .....                           | 5.10     | Displaying parameters with non-default values<br>only .....                           | 107        |
| 3.7 Free standing cubicle drive dimensions .....     | 5.11     | Displaying destination parameters only .....  | 107        |
| 3.8 Enclosure .....                                  | 5.12     | Serial communications .....   | 107        |
| 3.9 Cubicle design and drive ambient temperature ... | <b>6</b> | <b>Basic parameters (Menu 0) .....</b>  | <b>109</b> |
| 3.10 Heatsink fan operation .....                    | 6.1      | Single line descriptions .....  | 109        |
| 3.11 IP Rating (Ingress Protection) .....            | 6.2      | Full descriptions .....   | 114        |
| 3.12 External EMC filter .....                       | <b>7</b> | <b>Running the motor .....</b>  | <b>124</b> |
| 3.13 Heatsink mounted braking resistor .....         | 7.1      | Quick start Connections .....   | 124        |
| 3.14 Electrical terminals .....                      | 7.2      | Changing the operating mode .....   | 124        |
| 3.15 Routine maintenance .....                       | 7.3      | Quick Start commissioning .....   | 130        |
|  | 7.4      | Quick start commissioning (CTSoft) .....  | 134        |
|  | 7.5      | Setting up a feedback device .....  | 134        |
|  | <b>8</b> | <b>Optimisation .....</b>   | <b>138</b> |
|  | 8.1      | Motor map parameters .....  | 138        |
|  | 8.2      | Maximum motor rated current .....   | 148        |
|  | 8.3      | Current limits .....  | 148        |
|  | 8.4      | Motor thermal protection .....  | 148        |
|  | 8.5      | Switching frequency .....   | 149        |
|  | 8.6      | High speed operation .....  | 149        |

|           |   |            |
|-----------|---|------------|
| <b>9</b>  | <b>SMARTCARD operation</b>  | <b>151</b> |
| 9.1       | Introduction  | 151        |
| 9.2       | Transferring data   | 152        |
| 9.3       | Data block header information   | 154        |
| 9.4       | SMARTCARD parameters  | 154        |
| 9.5       | SMARTCARD trips   | 155        |
| <b>10</b> | <b>Onboard PLC</b>  | <b>157</b> |
| 10.1      | Onboard PLC and SYPTLite  | 157        |
| 10.2      | Benefits  | 157        |
| 10.3      | Limitations   | 157        |
| 10.4      | Getting started   | 158        |
| 10.5      | Onboard PLC parameters  | 158        |
| 10.6      | Onboard PLC trips   | 159        |
| 10.7      | Onboard PLC and the SMARTCARD   | 159        |
| <b>11</b> | <b>Advanced parameters</b>  | <b>160</b> |
| 11.1      | Menu 1: Frequency / speed reference   | 168        |
| 11.2      | Menu 2: Ramps   | 172        |
| 11.3      | Menu 3: Frequency slaving, speed feedback and speed control                 | 175        |
| 11.4      | Menu 4: Torque and current control  | 180        |
| 11.5      | Menu 5: Motor control   | 184        |
| 11.6      | Menu 6: Sequencer and clock   | 189        |
| 11.7      | Menu 7: Analogue I/O  | 191        |
| 11.8      | Menu 8: Digital I/O   | 194        |
| 11.9      | Menu 9: Programmable logic, motorised pot and binary sum                    | 198        |
| 11.10     | Menu 10: Status and trips   | 201        |
| 11.11     | Menu 11: General drive set-up   | 202        |
| 11.12     | Menu 12: Threshold detectors, variable selectors and brake control function | 203        |
| 11.13     | Menu 13: Position control   | 208        |
| 11.14     | Menu 14: User PID controller  | 214        |
| 11.15     | Menus 15, 16 and 17: Solutions Module set-up                                | 217        |
| 11.16     | Menu 18: Application menu 1   | 245        |
| 11.17     | Menu 19: Application menu 2   | 245        |
| 11.18     | Menu 20: Application menu 3   | 245        |
| 11.19     | Menu 21: Second motor parameters  | 246        |
| 11.20     | Menu 22: Additional Menu 0 set-up   | 247        |
| 11.21     | Advanced features   | 248        |
| <b>12</b> | <b>Technical Data</b>   | <b>257</b> |
| 12.1      | Drive   | 257        |
| 12.2      | Optional external EMC filters   | 272        |
| <b>13</b> | <b>Diagnostics</b>  | <b>275</b> |
| 13.1      | Trip indications  | 275        |
| 13.2      | Alarm indications   | 290        |
| 13.3      | Status indications  | 291        |
| 13.4      | Displaying the trip history   | 291        |
| <b>14</b> | <b>UL Listing Information</b>   | <b>292</b> |
| 14.1      | Common UL information   | 292        |
| 14.2      | Power dependant UL information  | 292        |
| 14.3      | AC supply specification   | 292        |
| 14.4      | Maximum continuous output current   | 292        |
| 14.5      | Safety label  | 292        |
| 14.6      | UL listed accessories   | 292        |

|                        |            |
|------------------------|------------|
| <b>List of figures</b> | <b>293</b> |
| <b>List of tables</b>  | <b>296</b> |
| <b>Index</b>           | <b>298</b> |

# Declaration of Conformity (Size 1 to 3)

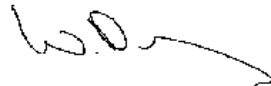
**Control Techniques Ltd**  
**The Gro**  
**Newtown**  
**Powys**  
**UK**  
**SY16 3BE**

|        |        |        |        |
|--------|--------|--------|--------|
| SP1201 | SP1202 | SP1203 | SP1204 |
| SP2201 | SP2202 | SP2203 |        |
| SP3201 | SP3202 |        |        |

|        |        |        |        |        |        |
|--------|--------|--------|--------|--------|--------|
| SP1401 | SP1402 | SP1403 | SP1404 | SP1405 | SP1406 |
| SP2401 | SP2402 | SP2403 | SP2404 |        |        |
| SP3401 | SP3402 | SP3403 |        |        |        |

|        |        |        |        |        |        |        |
|--------|--------|--------|--------|--------|--------|--------|
| SP3501 | SP3502 | SP3503 | SP3504 | SP3505 | SP3506 | SP3507 |
|--------|--------|--------|--------|--------|--------|--------|

These products comply with the Low Voltage Directive 73/23/EEC, the Electromagnetic Compatibility (EMC) Directive 89/336/EEC and the CE Marking Directive 93/68/EEC.



**W. Drury**  
**Executive Vice President, Technology**  
**Newtown**

**Date: 22nd July 2004**

The AC variable speed drive products listed above have been designed and manufactured in accordance with the following European harmonised standards:

|                           |   |
|---------------------------|---|
| EN 50178                  | Electronic equipment for use in power installations   |
| EN 61800-3                | Adjustable speed electrical power drive systems. EMC product standard including specific test methods   |
| EN 61000-6-2              | Electromagnetic compatibility (EMC). Generic standards. Immunity standard for industrial environments   |
| EN 61000-6-4              | Electromagnetic compatibility (EMC). Generic standards. Emission standard for industrial environments   |
| EN 50081-2                | Electromagnetic compatibility. Generic emission standard. Industrial environment  |
| EN 50082-2                | Electromagnetic compatibility. Generic immunity standard. Industrial environment  |
| EN 61000-3-2 <sup>1</sup> | Electromagnetic compatibility (EMC). Limits. Limits for harmonic current emissions (equipment input current up to and including 16 A per phase)                   |
| EN 61000-3-3              | Electromagnetic compatibility (EMC). Limits. Limitation of voltage fluctuations and flicker in low-voltage supply systems for equipment with rated current ≤ 16 A |

**These electronic drive products are intended to be used with appropriate motors, controllers, electrical protection components and other equipment to form complete end products or systems. Compliance with safety and EMC regulations depends upon installing and configuring drives correctly, including using the specified input filters. The drives must be installed only by professional assemblers who are familiar with requirements for safety and EMC. The assembler is responsible for ensuring that the end product or system complies with all the relevant laws in the country where it is to be used. Refer to this User Guide. An EMC Data Sheet is also available giving detailed EMC information.**

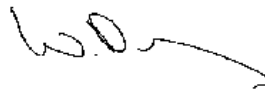
<sup>1</sup> These products are for professional use, and power input exceeds 1kW for all models, so no limits apply.

# Declaration of Conformity (Size 4 and 5)

**Control Techniques Ltd**  
**The Gro**  
**Newtown**  
**Powys**  
**UK**  
**SY16 3BE**

|        |        |        |        |        |        |
|--------|--------|--------|--------|--------|--------|
| SP4201 | SP4202 | SP4203 |        |        |        |
| SP4401 | SP4402 | SP4403 |        |        |        |
| SP5401 | SP5402 |        |        |        |        |
| SP4601 | SP4602 | SP4603 | SP4604 | SP4605 | SP4606 |
| SP5601 | SP5602 |        |        |        |        |

These products comply with the Low Voltage Directive 73/23/EEC, the Electromagnetic Compatibility (EMC) Directive 89/336/EEC and the CE Marking Directive 93/68/EEC.



The AC variable speed drive products listed above have been designed and manufactured in accordance with the following European harmonised standards:

|              |  |
|--------------|--|
| EN 61800-5-1 | Adjustable speed electrical power drive systems - safety requirements - electrical, thermal and energy |
| EN 61800-3   | Adjustable speed electrical power drive systems. EMC product standard including specific test methods  |
| EN 61000-6-2 | Electromagnetic compatibility (EMC). Generic standards. Immunity standard for industrial environments  |
| EN 61000-6-4 | Electromagnetic compatibility (EMC). Generic standards. Emission standard for industrial environments  |

**Executive Vice President, Technology**  
**Newtown**

**Date: 17th January 2005**

**These electronic drive products are intended to be used with appropriate motors, controllers, electrical protection components and other equipment to form complete end products or systems. Compliance with safety and EMC regulations depends upon installing and configuring drives correctly, including using the specified input filters. The drives must be installed only by professional assemblers who are familiar with requirements for safety and EMC. The assembler is responsible for ensuring that the end product or system complies with all the relevant laws in the country where it is to be used. Refer to the User Guide. An EMC Data Sheet is also available giving detailed EMC information.**

# Declaration of Conformity (Size 6)

**Control Techniques Ltd**  
**The Gro**  
**Newtown**  
**Powys**  
**UK**  
**SY16 3BE**

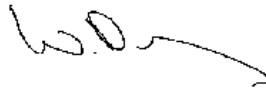
SP6401 SP6402

SP6601 SP6602

The AC variable speed drive products listed above have been designed and manufactured in accordance with the following European harmonised standards:

|              |  |
|--------------|--|
| EN 61800-5-1 | Adjustable speed electrical power drive systems - safety requirements - electrical, thermal and energy |
| EN 61800-3   | Adjustable speed electrical power drive systems. EMC product standard including specific test methods  |
| EN 61000-6-2 | Electromagnetic compatibility (EMC). Generic standards. Immunity standard for industrial environments  |

These products comply with the Low Voltage Directive 73/23/EEC, the Electromagnetic Compatibility (EMC) Directive 89/336/EEC and the CE Marking Directive 93/68/EEC.



**Executive Vice President, Technology**  
**Newtown**

**Date: 17th January 2005**

These electronic drive products are intended to be used with appropriate motors, controllers, electrical protection components and other equipment to form complete end products or systems. Compliance with safety and EMC regulations depends upon installing and configuring drives correctly, including using the specified input filters. The drives must be installed only by professional assemblers who are familiar with requirements for safety and EMC. The assembler is responsible for ensuring that the end product or system complies with all the relevant laws in the country where it is to be used. Refer to the User Guide. An EMC Data Sheet is also available giving detailed EMC information.

# Declaration of Conformity (Size 8 and 9)

**Control Techniques Ltd**  
**The Gro**  
**Newtown**  
**Powys**  
**UK**  
**SY16 3BE**

|        |        |        |        |
|--------|--------|--------|--------|
| SP8411 | SP8412 | SP8413 | SP8414 |
|--------|--------|--------|--------|

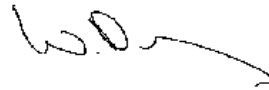
|        |        |        |        |        |
|--------|--------|--------|--------|--------|
| SP9411 | SP9412 | SP9413 | SP9414 | SP9415 |
|--------|--------|--------|--------|--------|

The AC variable speed drive products listed above have been designed and manufactured in accordance with the following European harmonised standards:

|               |  |
|---------------|--|
| EN 61800-5-1* | Adjustable speed electrical power drive systems - safety requirements - electrical, thermal and energy |
| EN 61800-3    | Adjustable speed electrical power drive systems. EMC product standard including specific test methods  |
| EN 61000-6-2  | Electromagnetic compatibility (EMC). Generic standards. Immunity standard for industrial environments  |

\*Clause 5.2.3.8 of EN 61800-5-1:2003 (breakdown of components test) has been amended to eliminate the 30A ground (earth) fuse, in accordance with the draft edition 2 of IEC 61800-5-1

These products comply with the Low Voltage Directive 73/23/EEC, the Electromagnetic Compatibility (EMC) Directive 89/336/EEC and the CE Marking Directive 93/68/EEC.




**Executive Vice President, Technology**  
**Newtown**

**Date: 11th October 2005**

**These electronic drive products are intended to be used with appropriate motors, controllers, electrical protection components and other equipment to form complete end products or systems. Compliance with safety and EMC regulations depends upon installing and configuring drives correctly, including using the specified input filters. The drives must be installed only by professional assemblers who are familiar with requirements for safety and EMC. The assembler is responsible for ensuring that the end product or system complies with all the relevant laws in the country where it is to be used. Refer to the User Guide. An EMC Data Sheet is also available giving detailed EMC information.**


# 1 Safety Information

## 1.1 Warnings, Cautions and Notes



A Warning contains information which is essential for avoiding a safety hazard.

**WARNING**



A Caution contains information which is necessary for avoiding a risk of damage to the product or other equipment.

**CAUTION**

### NOTE

A Note contains information which helps to ensure correct operation of the product.

## 1.2 Electrical safety - general warning

The voltages used in the drive can cause severe electrical shock and/or burns, and could be lethal. Extreme care is necessary at all times when working with or adjacent to the drive.

Specific warnings are given at the relevant places in this User Guide.

## 1.3 System design and safety of personnel

The drive is intended as a component for professional incorporation into complete equipment or a system. If installed incorrectly, the drive may present a safety hazard.

The drive uses high voltages and currents, carries a high level of stored electrical energy, and is used to control equipment which can cause injury.

Close attention is required to the electrical installation and the system design to avoid hazards either in normal operation or in the event of equipment malfunction. System design, installation, commissioning and maintenance must be carried out by personnel who have the necessary training and experience. They must read this safety information and this User Guide carefully.

The STOP and SECURE DISABLE functions of the drive do not isolate dangerous voltages from the output of the drive or from any external option unit. The supply must be disconnected by an approved electrical isolation device before gaining access to the electrical connections.

**With the sole exception of the SECURE DISABLE function, none of the drive functions must be used to ensure safety of personnel, i.e. they must not be used for safety-related functions.**

Careful consideration must be given to the functions of the drive which might result in a hazard, either through their intended behaviour or through incorrect operation due to a fault. In any application where a malfunction of the drive or its control system could lead to or allow damage, loss or injury, a risk analysis must be carried out, and where necessary, further measures taken to reduce the risk - for example, an over-speed protection device in case of failure of the speed control, or a fail-safe mechanical brake in case of loss of motor braking.

The SECURE DISABLE function has been approved<sup>1</sup> as meeting the requirements of EN954-1 category 3 for the prevention of unexpected starting of the drive. It may be used in a safety-related application. **The system designer is responsible for ensuring that the complete system is safe and designed correctly according to the relevant safety standards.**

<sup>1</sup>Independent approval by BGIA has been given.

## 1.4 Environmental limits

Instructions in this User Guide regarding transport, storage, installation and use of the drive must be complied with, including the specified environmental limits. Drives must not be subjected to excessive physical force.

## 1.5 Compliance with regulations

The installer is responsible for complying with all relevant regulations, such as national wiring regulations, accident prevention regulations and electromagnetic compatibility (EMC) regulations. Particular attention must be given to the cross-sectional areas of conductors, the selection of fuses or other protection, and protective earth (ground) connections.

This User Guide contains instruction for achieving compliance with specific EMC standards.

Within the European Union, all machinery in which this product is used must comply with the following directives:

98/37/EC: Safety of machinery.

89/336/EEC: Electromagnetic Compatibility.

## 1.6 Motor

Ensure the motor is installed in accordance with the manufacturer's recommendations. Ensure the motor shaft is not exposed.

Standard squirrel cage induction motors are designed for single speed operation. If it is intended to use the capability of the drive to run a motor at speeds above its designed maximum, it is strongly recommended that the manufacturer is consulted first.

Low speeds may cause the motor to overheat because the cooling fan becomes less effective. The motor should be fitted with a protection thermistor. If necessary, an electric forced vent fan should be used.

The values of the motor parameters set in the drive affect the protection of the motor. The default values in the drive should not be relied upon.

It is essential that the correct value is entered in parameter **0.46** motor rated current. This affects the thermal protection of the motor.

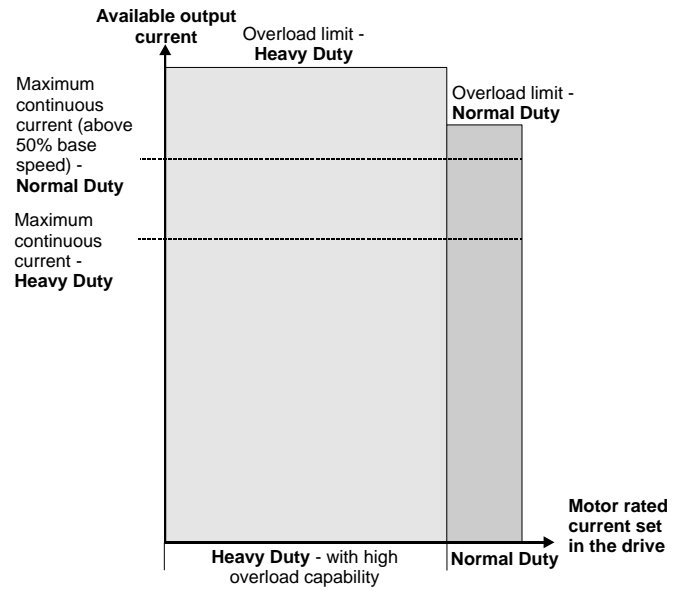
## 1.7 Adjusting parameters

Some parameters have a profound effect on the operation of the drive. They must not be altered without careful consideration of the impact on the controlled system. Measures must be taken to prevent unwanted changes due to error or tampering.

## 2 Product Information

### 2.1 Ratings

The Unidrive SP is dual rated.  
 The setting of the motor rated current determines which rating applies - Heavy Duty or Normal Duty.  
 The two ratings are compatible with motors designed to IEC60034.  
 The graph aside illustrates the difference between Normal Duty and Heavy Duty with respect to continuous current rating and short term overload limits.



#### Normal Duty

For applications which use self ventilated induction motors and require a low overload capability (e.g. fans, pumps).  
 Self ventilated induction motors require increased protection against overload due to the reduced cooling effect of the fan at low speed. To provide the correct level of protection the I<sup>2</sup>t software operates at a level which is speed dependent. This is illustrated in the graph below.

#### NOTE

The speed at which the low speed protection takes effect can be changed by the setting of Pr 4.25. The protection starts when the motor speed is below 15% of base speed when Pr 4.25 = 0 (default) and below 50% when Pr 4.25 = 1.

#### Heavy Duty (default)

For constant torque applications or applications which require a high overload capability (e.g. winders, hoists).  
 The thermal protection is set to protect force ventilated induction motors and permanent magnet servo motors by default.

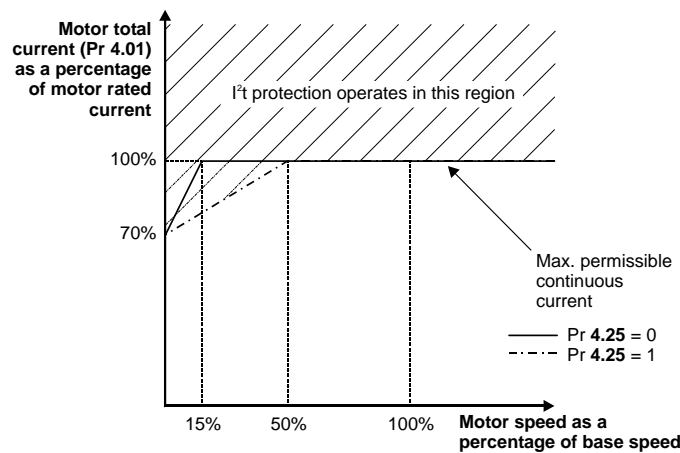
#### NOTE

If the application uses a self ventilated motor and increased thermal protection is required for speeds below 50% base speed, then this can be enabled by setting Pr 4.25 = 1.

#### Operation of motor I<sup>2</sup>t protection (I<sub>t</sub>AC trip)

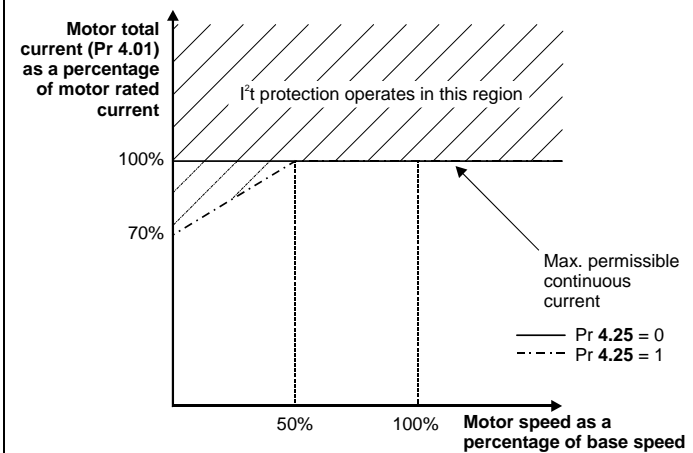
Motor I<sup>2</sup>t protection is fixed as shown below and is compatible with:

- Self ventilated induction motors







Motor I<sup>2</sup>t protection defaults to be compatible with:

- Forced ventilation induction motors
- Permanent magnet servo motors








The continuous current ratings given are for maximum 40°C (104°F), 1000m altitude and 3.0 kHz switching. Derating is required for higher switching frequencies, ambient temperature >40°C (104°F) and high altitude. For further information, refer to section 12.1.1 *Power and current ratings (Derating for switching frequency and temperature)* on page 257.

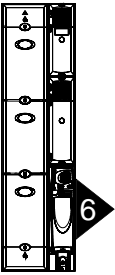
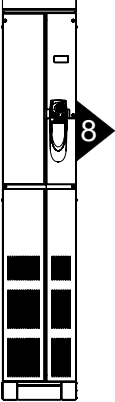
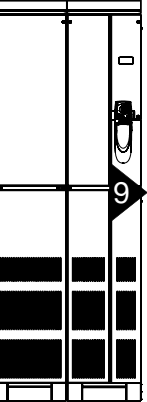
**Table 2-1 200V Drive ratings (200V to 240V ±10%)**

| Model  |      | Normal Duty                       |                       |                     |              | Heavy Duty                        |                        |                          |                       |                     |
|--|------|-----------------------------------|-----------------------|---------------------|--------------|-----------------------------------|------------------------|--------------------------|-----------------------|---------------------|
|  |      | Maximum continuous output current | Nominal power at 220V | Motor power at 230V | Peak current | Maximum continuous output current | Open loop peak current | Closed loop peak current | Nominal power at 220V | Motor power at 230V |
|  |      | A                                 | kW                    | hp                  | A            | A                                 | A                      | A                        | kW                    | hp                  |
|  | 1201 | 5.2                               | 1.1                   | 1.5                 | 5.7          | 4.3                               | 6.4                    | 7.5                      | 0.75                  | 1.0                 |
|  | 1202 | 6.8                               | 1.5                   | 2.0                 | 7.4          | 5.8                               | 8.7                    | 10.1                     | 1.1                   | 1.5                 |
|  | 1203 | 9.6                               | 2.2                   | 3.0                 | 10.5         | 7.5                               | 11.2                   | 13.1                     | 1.5                   | 2.0                 |
|  | 1204 | 11                                | 3.0                   | 3.0                 | 12.1         | 10.6                              | 15.9                   | 18.5                     | 2.2                   | 3.0                 |
|  | 2201 | 15.5                              | 4.0                   | 5.0                 | 17.0         | 12.6                              | 18.9                   | 22                       | 3.0                   | 3.0                 |
|  | 2202 | 22                                | 5.5                   | 7.5                 | 24.2         | 17                                | 25.5                   | 29.7                     | 4.0                   | 5.0                 |
|  | 2203 | 28                                | 7.5                   | 10                  | 30.8         | 25                                | 37.5                   | 43.7                     | 5.5                   | 7.5                 |
|  | 3201 | 42                                | 11                    | 15                  | 46           | 31                                | 46.5                   | 54.2                     | 7.5                   | 10                  |
|  | 3202 | 54                                | 15                    | 20                  | 59           | 42                                | 63                     | 73.5                     | 11                    | 15                  |
|  | 4201 | 68                                | 18.5                  | 25                  | 74           | 56                                | 84                     | 98                       | 15                    | 20                  |
|  | 4202 | 80                                | 22                    | 30                  | 88           | 68                                | 102                    | 119                      | 18.5                  | 25                  |
|  | 4203 | 104                               | 30                    | 40                  | 114          | 80                                | 120                    | 140                      | 22                    | 30                  |

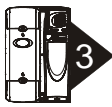
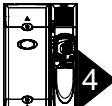
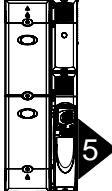
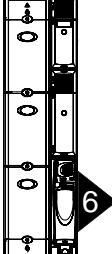
**Table 2-2 400V Drive ratings (380V to 480V ±10%)**

| Model  |      | Normal Duty                       |                       |                     |              | Heavy Duty                        |                        |                          |                       |                     |
|--|------|-----------------------------------|-----------------------|---------------------|--------------|-----------------------------------|------------------------|--------------------------|-----------------------|---------------------|
|  |      | Maximum continuous output current | Nominal power at 400V | Motor power at 460V | Peak current | Maximum continuous output current | Open loop peak current | Closed loop peak current | Nominal power at 400V | Motor power at 460V |
|  |      | A                                 | kW                    | hp                  | A            | A                                 | A                      | A                        | kW                    | hp                  |
|  | 1401 | 2.8                               | 1.1                   | 1.5                 | 3.0          | 2.1                               | 3.1                    | 3.6                      | 0.75                  | 1.0                 |
|  | 1402 | 3.8                               | 1.5                   | 2.0                 | 4.1          | 3.0                               | 4.5                    | 5.2                      | 1.1                   | 2.0                 |
|  | 1403 | 5.0                               | 2.2                   | 3.0                 | 5.5          | 4.2                               | 6.3                    | 7.3                      | 1.5                   | 3.0                 |
|  | 1404 | 6.9                               | 3.0                   | 5.0                 | 7.5          | 5.8                               | 8.7                    | 10.1                     | 2.2                   | 3.0                 |
|  | 1405 | 8.8                               | 4.0                   | 5.0                 | 9.6          | 7.6                               | 11.4                   | 13.3                     | 3.0                   | 5.0                 |
|  | 1406 | 11                                | 5.5                   | 7.5                 | 12.1         | 9.5                               | 14.2                   | 16.6                     | 4.0                   | 5.0                 |
|  | 2401 | 15.3                              | 7.5                   | 10                  | 16.8         | 13                                | 19.5                   | 22.7                     | 5.5                   | 10                  |
|  | 2402 | 21                                | 11                    | 15                  | 23           | 16.5                              | 24.7                   | 28.8                     | 7.5                   | 10                  |
|  | 2403 | 29                                | 15                    | 20                  | 31           | 25                                | 34.5                   | 40.2                     | 11                    | 20                  |
|  | 2404 |                                   |                       |                     |              | 29                                | 43.5                   | 50.7                     | 15                    | 20                  |
|  | 3401 | 35                                | 18.5                  | 25                  | 38           | 32                                | 48                     | 56                       | 15                    | 25                  |
|  | 3402 | 43                                | 22                    | 30                  | 47           | 40                                | 60                     | 70                       | 18.5                  | 30                  |
|  | 3403 | 56                                | 30                    | 40                  | 61           | 46                                | 69                     | 80.5                     | 22                    | 30                  |
|  | 4401 | 68                                | 37                    | 50                  | 74           | 60                                | 90                     | 105                      | 30                    | 50                  |
|  | 4402 | 83                                | 45                    | 60                  | 91           | 74                                | 111                    | 129.5                    | 37                    | 60                  |
|  | 4403 | 104                               | 55                    | 75                  | 114          | 96                                | 144                    | 168                      | 45                    | 75                  |
|  | 5401 | 138                               | 75                    | 100                 | 151          | 124                               | 186                    | 217                      | 55                    | 100                 |
|  | 5402 | 168                               | 90                    | 125                 | 184          | 156                               | 234                    | 273                      | 75                    | 125                 |

**Table 2-2 400V Drive ratings (380V to 480V ±10%)**

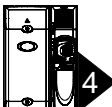
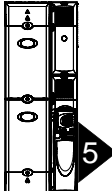
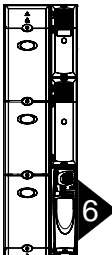
| Model  | Normal Duty                       |                       |                     |              |                                   | Heavy Duty             |                          |                       |                     |     |
|--|-----------------------------------|-----------------------|---------------------|--------------|-----------------------------------|------------------------|--------------------------|-----------------------|---------------------|-----|
|  | Maximum continuous output current | Nominal power at 400V | Motor power at 460V | Peak current | Maximum continuous output current | Open loop peak current | Closed loop peak current | Nominal power at 400V | Motor power at 460V |     |
|  | A                                 | kW                    | hp                  | A            | A                                 | A                      | kW                       | hp                    |                     |     |
|   | 6401                              | 205                   | 110                 | 150          | 225                               | 180                    | 231                      | 269                   | 90                  | 150 |
|  | 6402                              | 236                   | 132                 | 200          | 259                               | 210                    | 270                      | 315                   | 110                 | 150 |
|   | 8411                              | 389                   | 225                 | 300          | 428                               | 335                    | 432                      | 503                   | 185                 | 280 |
|  | 8412                              | 450                   | 250                 | 400          | 495                               | 389                    | 502                      | 584                   | 225                 | 300 |
|  | 8413                              | 545                   | 315                 | 450          | 600                               | 450                    | 581                      | 675                   | 250                 | 400 |
|  | 8414                              | 620                   | 355                 | 500          | 682                               | 545                    | 703                      | 818                   | 315                 | 450 |
|  | 9411                              | 690                   | 400                 | 600          | 759                               | 620                    | 800                      | 930                   | 355                 | 500 |
|  | 9412                              | 790                   | 450                 | 700          | 869                               | 690                    | 882                      | 1026                  | 400                 | 600 |
|  | 9413                              | 900                   | 500                 | 800          | 990                               | 790                    | 1019                     | 1185                  | 450                 | 700 |
|  | 9414                              | 1010                  | 560                 | 900          | 1111                              | 900                    | 1125                     | 1305                  | 500                 | 800 |
|  | 9415                              | 1164                  | 675                 | 1000         | 1280                              | 1010                   | 1303                     | 1515                  | 560                 | 900 |

**Table 2-3 575V Drive ratings (500V to 575V ±10%)**

| Model   | Normal Duty                       |                       |                     |              |                                   | Heavy Duty             |                          |                       |                     |     |
|---|-----------------------------------|-----------------------|---------------------|--------------|-----------------------------------|------------------------|--------------------------|-----------------------|---------------------|-----|
|   | Maximum continuous output current | Nominal power at 575V | Motor power at 575V | Peak current | Maximum continuous output current | Open loop peak current | Closed loop peak current | Nominal power at 575V | Motor power at 575V |     |
|   | A                                 | kW                    | hp                  | A            | A                                 | A                      | A                        | kW                    | hp                  |     |
|   | 3501                              | 5.4                   | 3.0                 | 3.0          | 5.9                               | 4.1                    | 6.1                      | 7.1                   | 2.2                 | 2.0 |
|   | 3502                              | 6.1                   | 4.0                 | 5.0          | 6.7                               | 5.4                    | 8.1                      | 9.4                   | 3.0                 | 3.0 |
|   | 3503                              | 8.4                   | 5.5                 | 7.5          | 9.2                               | 6.1                    | 9.1                      | 10.6                  | 4.0                 | 5.0 |
|   | 3504                              | 11                    | 7.5                 | 10           | 12.1                              | 9.5                    | 14.2                     | 16.6                  | 5.5                 | 7.5 |
|   | 3505                              | 16                    | 11                  | 15           | 17.6                              | 12                     | 18                       | 21                    | 7.5                 | 10  |
|   | 3506                              | 22                    | 15                  | 20           | 24.2                              | 18                     | 27                       | 31.5                  | 11                  | 15  |
|   | 3507                              | 27                    | 18.5                | 25           | 29.7                              | 22                     | 33                       | 38.5                  | 15                  | 20  |
|   | 4603                              | 36                    | 22                  | 30           | 39.6                              | 27                     | 40.5                     | 47.2                  | 18.5                | 25  |
|   | 4604                              | 43                    | 30                  | 40           | 47.3                              | 36                     | 54                       | 63                    | 22                  | 30  |
|   | 4605                              | 52                    | 37                  | 50           | 57.2                              | 43                     | 64.5                     | 75.2                  | 30                  | 40  |
|   | 4606                              | 62                    | 45                  | 60           | 68                                | 52                     | 78                       | 91                    | 37                  | 50  |
|   | 5601                              | 84                    | 55                  | 75           | 92                                | 63                     | 93                       | 108.5                 | 45                  | 60  |
|   | 5602                              | 99                    | 75                  | 100          | 108                               | 85                     | 126                      | 147                   | 55                  | 75  |
|  | 6601                              | 125                   | 90                  | 125          | 137                               | 100                    | 128                      | 149                   | 75                  | 100 |
|   | 6602                              | 144                   | 110                 | 150          | 158                               | 125                    | 160                      | 187                   | 90                  | 125 |

The power ratings above for model size 4 and larger are for the 690V drives when used on a 500V to 575V supply.

**Table 2-4 690V Drive ratings (500V to 690V ±10%)**

| Model  | Normal Duty                       |                       |                     |              |                                   | Heavy Duty             |                          |                       |                     |     |
|--|-----------------------------------|-----------------------|---------------------|--------------|-----------------------------------|------------------------|--------------------------|-----------------------|---------------------|-----|
|  | Maximum continuous output current | Nominal power at 690V | Motor power at 690V | Peak current | Maximum continuous output current | Open loop peak current | Closed loop peak current | Nominal power at 690V | Motor power at 690V |     |
|  | A                                 | kW                    | hp                  | A            | A                                 | A                      | A                        | kW                    | hp                  |     |
|  | 4601                              | 22                    | 18.5                | 25           | 24.2                              | 19                     | 27                       | 31.5                  | 15                  | 20  |
|  | 4602                              | 27                    | 22                  | 30           | 29.7                              | 22                     | 33                       | 38.5                  | 18.5                | 25  |
|  | 4603                              | 36                    | 30                  | 40           | 39.6                              | 27                     | 40.5                     | 47.2                  | 22                  | 30  |
|  | 4604                              | 43                    | 37                  | 50           | 47.3                              | 36                     | 54                       | 63                    | 30                  | 40  |
|  | 4605                              | 52                    | 45                  | 60           | 57.2                              | 43                     | 64.5                     | 75.2                  | 37                  | 50  |
|  | 4606                              | 62                    | 55                  | 75           | 68.2                              | 52                     | 78                       | 91                    | 45                  | 60  |
|  | 5601                              | 84                    | 75                  | 100          | 92                                | 63                     | 93                       | 108.5                 | 55                  | 75  |
|  | 5602                              | 99                    | 90                  | 125          | 108                               | 85                     | 126                      | 147                   | 75                  | 100 |
|  | 6601                              | 125                   | 110                 | 150          | 137                               | 100                    | 128                      | 149                   | 90                  | 125 |
|  | 6602                              | 144                   | 132                 | 175          | 158                               | 125                    | 160                      | 187                   | 110                 | 150 |

### 2.1.1 Typical short term overload limits

The maximum percentage overload limit changes depending on the selected motor. Variations in motor rated current, motor power factor and motor leakage inductance all result in changes in the maximum possible overload. The exact value for a specific motor can be calculated using the equations detailed in Menu 4 in the *Unidrive SP Advanced User Guide*.

Typical values are shown in the table below for closed loop vector (VT) and open loop (OL) modes:

**Table 2-5 Typical overload limits for size 1 to 5**

| Operating mode  | Closed loop from cold | Closed loop from 100% | Open loop from cold | Open loop from 100% |
|---|-----------------------|-----------------------|---------------------|---------------------|
| Normal Duty overload with motor rated current = drive rated current | 110% for 215s         | 110% for 5s           | 110% for 215s       | 110% for 5s         |
| Heavy Duty overload with motor rated current = drive rated current  | 175% for 40s          | 175% for 5s           | 150% for 60s        | 150% for 8s         |
| Heavy Duty overload with a typical 4 pole motor                     | 200% for 28s          | 200% for 3s           | 175% for 40s        | 175% for 5s         |

**Table 2-6 Typical overload limits for size 6 and above**

| Operating mode  | Closed loop from cold | Closed loop from 100% | Open loop from cold | Open loop from 100% |
|---|-----------------------|-----------------------|---------------------|---------------------|
| Normal Duty overload with motor rated current = drive rated current | 110% for 165s         | 110% for 9s           | 110% for 165s       | 110% for 9s         |
| Heavy Duty overload with motor rated current = drive rated current  | 150% for 60s          | 150% for 8s           | 129% for 97s        | 129% for 15s        |

Generally the drive rated current is higher than the matching motor rated current allowing a higher level of overload than the default setting as illustrated by the example of a typical 4 pole motor.

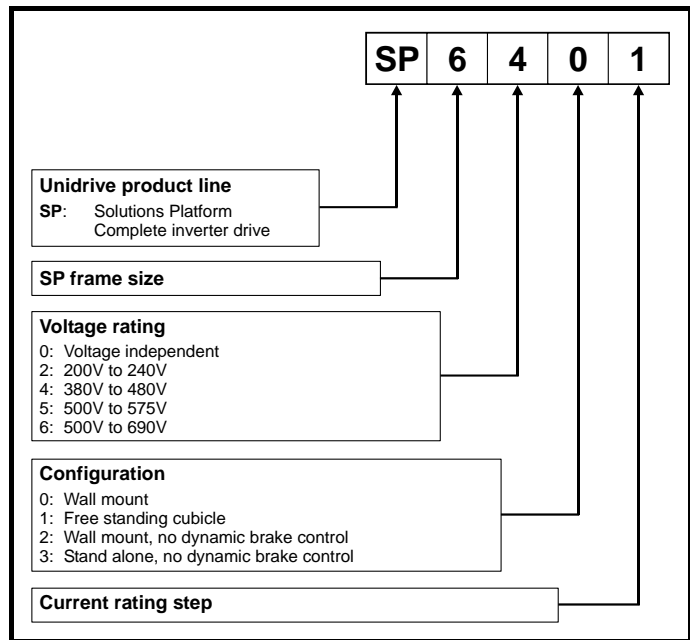
The time allowed in the overload region is proportionally reduced at very low output frequency on some drive ratings.

**NOTE**

The maximum overload level which can be attained is independent of the speed.

## 2.2 Model number

The way in which the model numbers for the Unidrive SP range are formed is illustrated below.



## 2.3 Operating modes

The Unidrive SP is designed to operate in any of the following modes:

- Open loop mode
  - Open loop vector
  - Fixed V/F mode (V/Hz)
  - Quadratic V/F mode (V/Hz)
- RFC mode
- Closed loop vector
- Servo
- Regen

### 2.3.1 Open loop mode

For use with standard AC induction motors.

The drive applies power to the motor at frequencies varied by the user. The motor speed is a result of the output frequency of the drive and slip due to the mechanical load. The drive can improve the speed control of

the motor by applying slip compensation. The performance at low speed depends on whether V/F mode or open loop vector mode is selected.

#### Open loop vector mode

The voltage applied to the motor is directly proportional to the frequency except at low speed where the drive uses motor parameters to apply the correct voltage to keep the flux constant under varying load conditions.

Typically 100% torque is available down to 1Hz for a 50Hz motor.

#### Fixed V/F mode

The voltage applied to the motor is directly proportional to the frequency except at low speed where a voltage boost is provided which is set by the user. This mode can be used for multi-motor applications.

Typically 100% torque is available down to 4Hz for a 50Hz motor.

#### Quadratic V/F mode

The voltage applied to the motor is directly proportional to the square of the frequency except at low speed where a voltage boost is provided which is set by the user. This mode can be used for running fan or pump applications with quadratic load characteristics or for multi-motor applications. This mode is not suitable for applications requiring a high starting torque.

### 2.3.2 RFC mode

For use with induction motors.

Rotor flux control uses closed loop current control which allows the same overload current as closed loop modes and eliminates low load instability which can be associated with traditional open loop control.

### 2.3.3 Closed loop vector mode

For use with induction motors with a feedback device fitted.

The drive directly controls the speed of the motor using the feedback device to ensure the rotor speed is exactly as demanded. Motor flux is accurately controlled at all times to provide full torque all the way down to zero speed.

### 2.3.4 Servo

For use with permanent magnet brushless motors with a feedback device fitted.

The drive directly controls the speed of the motor using the feedback device to ensure the rotor speed is exactly as demanded. Flux control is not required because the motor is self excited by the permanent magnets which form part of the rotor.

Absolute position information is required from the feedback device to ensure the output voltage is accurately matched to the back EMF of the motor. Full torque is available all the way down to zero speed.

### 2.3.5 Regen

For use as a regenerative front end for four quadrant operation.

Regen operation allows bi-directional power flow to and from the AC supply. This provides far greater efficiency levels in applications which would otherwise dissipate large amounts of energy in the form of heat in a braking resistor.

The harmonic content of the input current is negligible due to the sinusoidal nature of the waveform when compared to a conventional bridge rectifier or thyristor front end.

See the *Unidrive SP Regen Installation Guide* for more information about operation in this mode.

## 2.4 Compatible encoders

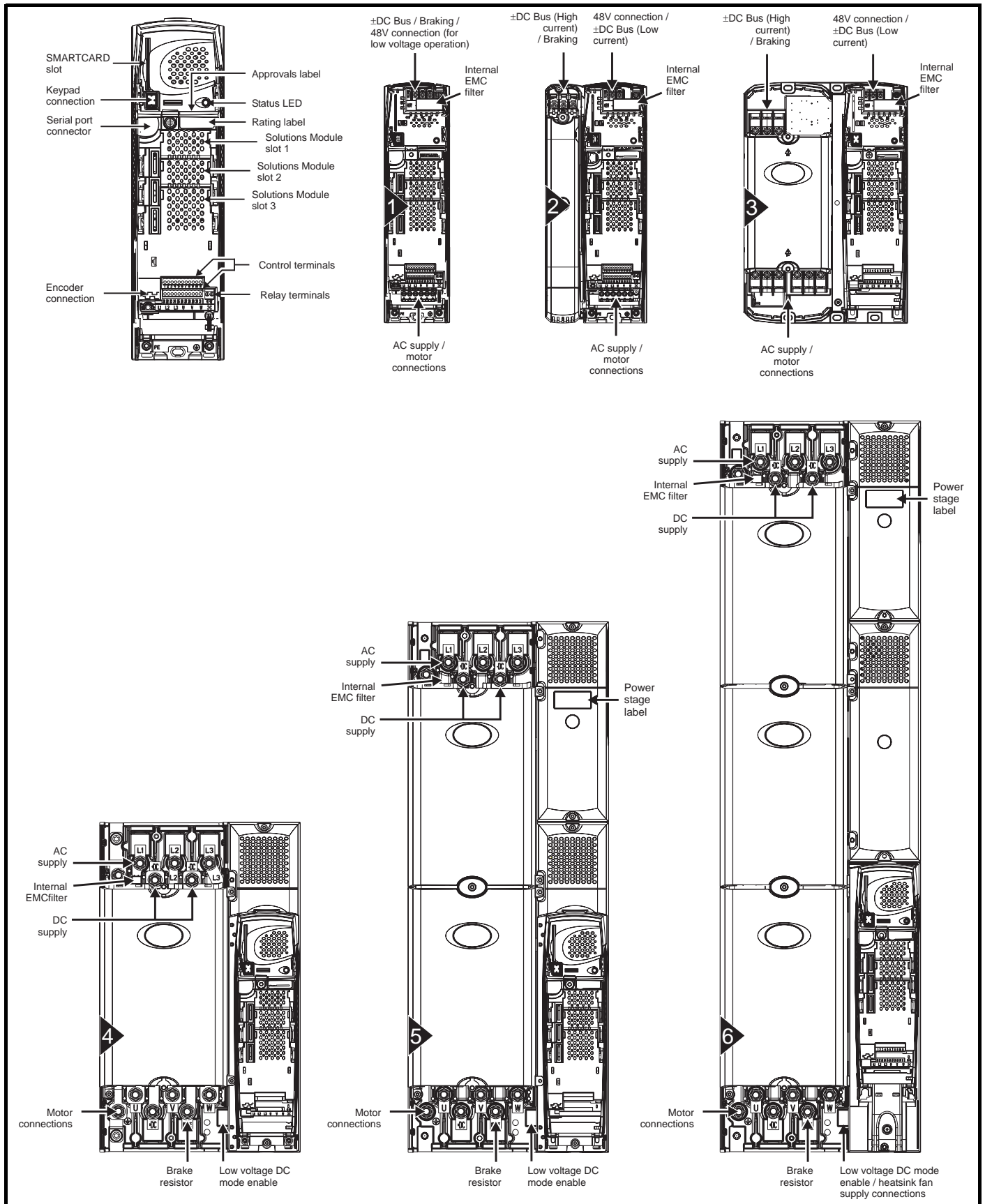
Table 2-7 Encoders compatible with Unidrive SP

| Encoder type   | Pr 3.38 setting |
|--|-----------------|
| Quadrature incremental encoders with or without marker pulse   | Ab (0)          |
| Quadrature incremental encoders with UVW commutation signals for absolute position for permanent magnet motors with or without marker pulse              | Ab.SERvo (3)    |
| Forward / reverse incremental encoders with or without marker pulse  | Fr (2)          |
| Forward / reverse incremental encoders with UVW commutation signals for absolute position for permanent magnet motors with or without marker pulse       | Fr.SERvo (5)    |
| Frequency and direction incremental encoders with or without marker pulse  | Fd (1)          |
| Frequency and direction incremental encoders with UVW commutation signals for absolute position for permanent magnet motors with or without marker pulse | Fd.SERvo (4)    |
| Sincos incremental encoders  | SC (6)          |
| Heidenhain sincos encoders with Endat comms for absolute position  | SC.EndAt (9)    |
| Stegmann sincos encoders with Hiperface comms for absolute position  | SC.HiPEr (7)    |
| Sincos encoders with SSI comms for absolute position   | SC.SSI (11)     |
| SSI encoders (Gray code or binary)   | SSI (10)        |
| Endat comms only encoders  | EndAt (8)       |
| UVW commutation only encoders*   | Ab.SERvo (3)    |

\* This feedback device provides very low resolution feedback and should not be used for applications requiring a high level of performance

## 2.5 Drive features

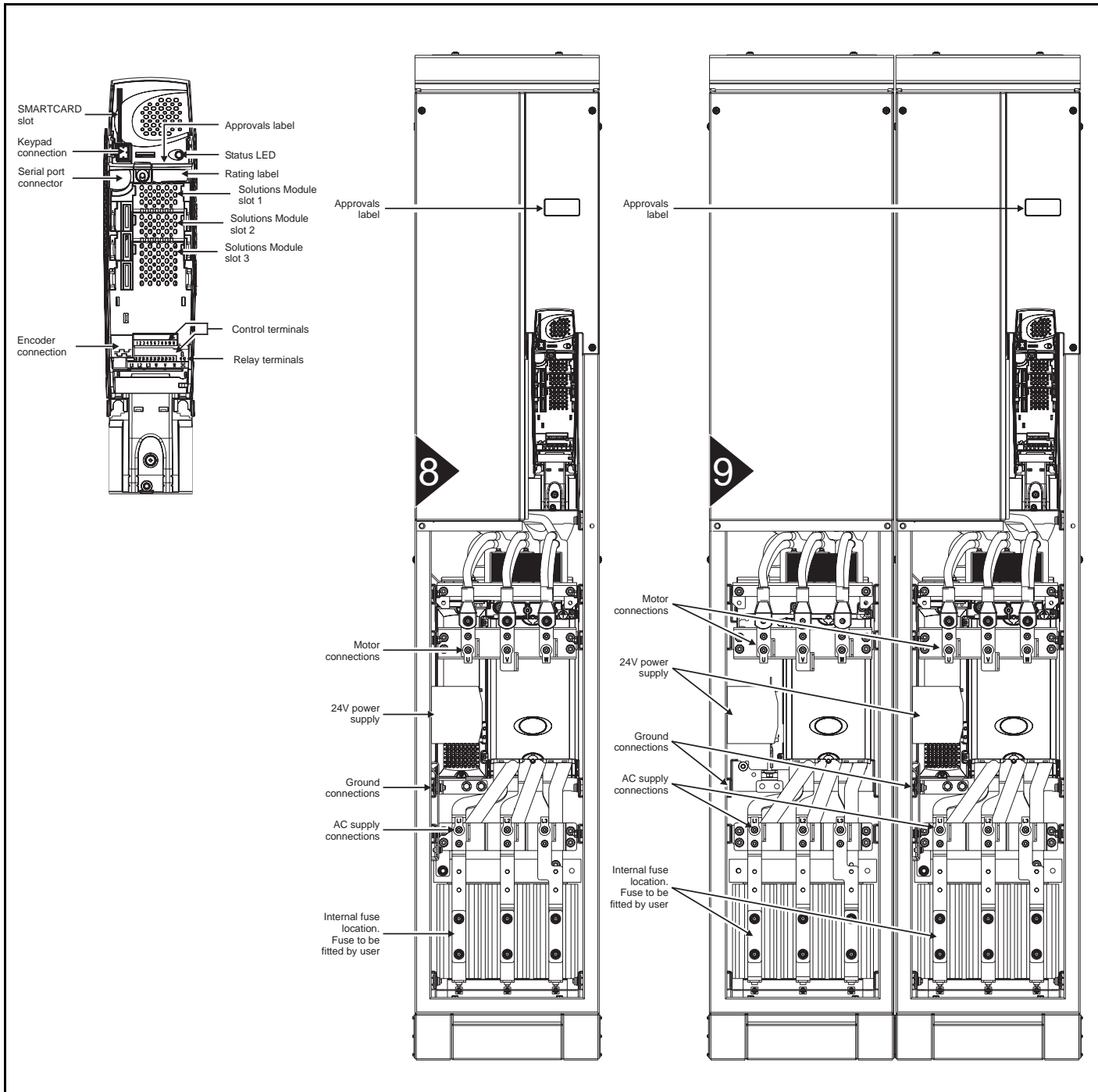
Figure 2-1 Features of the wall mounted drive



**NOTE**

The Unidrive SP size 6 requires a 24V fan supply.

**Figure 2-2 Features of the free standing cubicle drive**



## 2.6 Nameplate description

See Figure 2-1 *Features of the wall mounted drive* for location of rating labels.

Figure 2-3 Typical drive rating labels

**Rating label (size 1 to 6)**

Input voltage rating: I/P 200-240V  
 Input frequency: 50-60Hz  
 No. of phases: 3ph  
 Typical input current for Normal Duty rating: 6.6A  
 Model: SP1201  
 S.No.: 300005001  
 Serial number: 300005001  
 Output voltage range: O/P 0-240V  
 Heavy Duty / Normal Duty rating output current: 4.3 / 5.2A

**Approvals label (Size 1 to 6)**

Model: SP1201  
 Heavy Duty / Normal Duty power rating: 0.75 / 1.1kW  
 Please read manual before connecting.  
 Electric Shock Risk: Wait 10 min between disconnecting supply & removing covers  
 Approvals: UL US, CE, N1652  
 SP 1,5 TL  
 Ser No: 300005001  
 Made In U.K.  
 Customer and date code: STDL25

**Power stage label (Size 5 and 6 only)**

Model: SP5402  
 Heavy Duty / Normal Duty power rating: 75 / 90kW  
 Customer and date code: STDN39  
 Please read manual before connecting.  
 Electric Shock Risk: Wait 10 min between disconnecting supply & removing covers  
 Approvals: UL US, CE, N1652  
 Input voltage: I/P 380-480V  
 Output voltage: O/P 0-480V  
 Serial number: 300005001  
 Input frequency: 50-60Hz  
 Heavy Duty / Normal Duty rating output current: 156 / 168A  
 No. of phases & Typical input current for Normal Duty rating: 3ph 152.0A  
 SP 100 T  
 Made In U.K.  
 E171230

**Approvals label (Free standing cubicle drive)**

Model: SPM8414  
 Heavy Duty / Normal Duty power rating: 315/355kW  
 Customer and date code: STDN39  
 Please read manual before connecting.  
 Electric Shock Risk: Wait 10 mins between disconnecting supply & removing covers  
 Approvals: UL US, CE, N1652  
 Input voltage: I/P 380-480V  
 Output voltage: O/P 0-480V  
 Serial number: 300005001  
 Input frequency: 50-60Hz  
 Heavy Duty / Normal Duty rating output current: 540/620A  
 No. of phases & Typical input current for Normal Duty rating: 3ph 678A  
 IND. CONT. EQ. LISTED8D14  
 Made in U.K.  
 E171230  
 www.controltechniques.com

**Key to approvals**

|  |                   |              |
|--|-------------------|--------------|
|  | CE approval       | Europe       |
|  | C Tick approval   | Australia    |
|  | UL / cUL approval | USA & Canada |

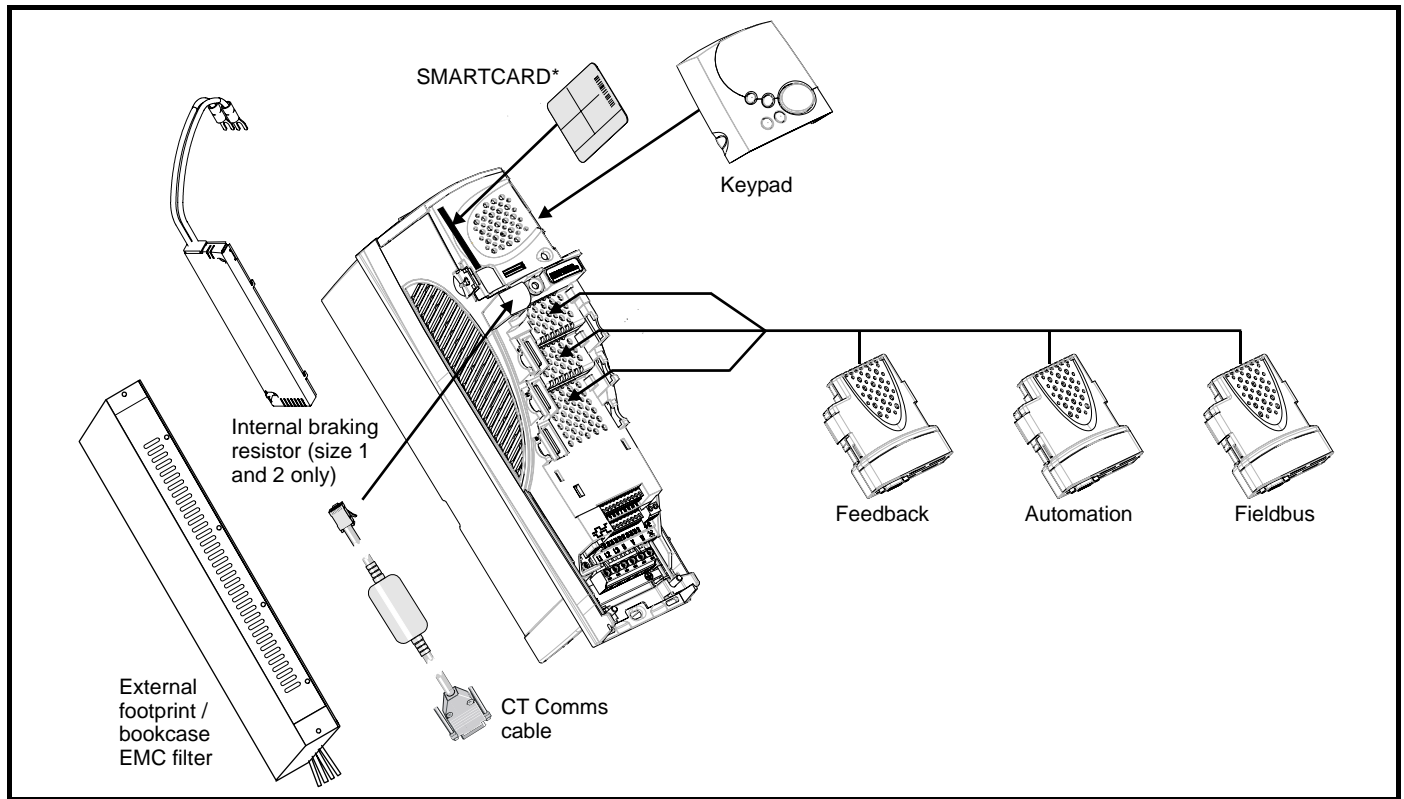
Unidrive SP User Guide  
 Issue Number: 11

www.controltechniques.com

19

## 2.7 Options





Figure 2-4 Options available with Unidrive SP













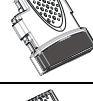
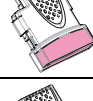



\* A SMARTCARD is provided with the Unidrive SP as standard. For further information, refer to Chapter 9 *SMARTCARD operation* on page 151.

All Unidrive SP Solutions Modules are colour-coded in order to make identification easy. The following table shows the colour-code key and gives further details on their function.


Table 2-8 Solutions Module identification

| Type     | Solutions Module  | Colour      | Name                      | Further Details   |
|----------|---|-------------|---------------------------|---|
| Feedback |  | Light Green | SM-Universal Encoder Plus | <b>Universal Feedback interface</b><br>Feedback interface for the following devices:<br><b>Inputs</b> <ul style="list-style-type: none"> <li>Incremental encoders</li> <li>SinCos encoders</li> <li>SSI encoders</li> <li>EnDat encoders</li> </ul> <b>Outputs</b> <ul style="list-style-type: none"> <li>Quadrature</li> <li>Frequency and direction</li> <li>SSI simulated outputs</li> </ul> |
|          |  | Light Blue  | SM-Resolver               | <b>Resolver interface</b><br>Feedback interface for resolvers.<br>Simulated quadrature encoder outputs  |
|          |  | Brown       | SM-Encoder Plus           | <b>Incremental encoder interface</b><br>Feedback interface for incremental encoders without commutation signals.<br>No simulated encoder outputs available  |
|          |  | N/A         | 15-way D-type converter   | <b>Drive encoder input converter</b><br>Provides screw terminal interface for encoder wiring and spade terminal for shield  |



**Table 2-8 Solutions Module identification**

| Type       | Solutions Module  | Colour      | Name                 | Further Details   |
|------------|---|-------------|----------------------|---|
| Automation |    | Yellow      | SM-I/O Plus          | <b>Extended I/O interface</b><br>Increases the I/O capability by adding the following to the existing I/O in the drive:<br><ul style="list-style-type: none"> <li>Digital inputs x 3</li> <li>Digital I/O x 3</li> <li>Analogue inputs (voltage) x 2</li> <li>Analogue output (voltage) x 1</li> <li>Relay x 2</li> </ul> |
|            |    | Dark Green  | SM-Applications      | <b>Applications Processor (with CTNet)</b><br>2 <sup>nd</sup> processor for running pre-defined and /or customer created application software with CTNet support  |
|            |    | White       | SM-Applications Lite | <b>Applications Processor</b><br>2 <sup>nd</sup> processor for running pre-defined and /or customer created application software  |
|            |    | Dark Blue   | SM-EZMotion          | <b>Motion Controller</b><br>1½ axis motion controller with processor for running customer created application specific software.  |
|            |    | Dark Yellow | SM-I/O Lite          | <b>Additional I/O</b><br>1 x Analogue input (± 10V bi-polar or current modes)<br>1 x Analogue output (0-10V or current modes)<br>3 x Digital input and 1 x Relay  |
|            |    | Dark Red    | SM-I/O Timer         | <b>Additional I/O with real time clock</b><br>As per SM-I/O Lite but with the addition of a Real Time Clock for scheduling drive running  |
|            |   | Turquoise   | SM-PELV              | <b>Isolated I/O to NAMUR NE37 specifications</b><br>For chemical industry applications<br>1 x Analogue input (current modes)<br>2 x Analogue outputs (current modes)<br>4 x Digital input / outputs, 1 x Digital input, 2 x Relay outputs   |
|            |  | Olive       | SM-I/O 120V          | <b>Additional I/O conforming to IEC 1131-2 120Vac</b><br>6 digital inputs and 2 relay outputs rated for 120Vac operation  |
| Fieldbus   |  | Purple      | SM-PROFIBUS-DP       | <b>Profibus option</b><br>PROFIBUS DP adapter for communications with the Unidrive SP.  |
|            |  | Medium Grey | SM-DeviceNet         | <b>DeviceNet option</b><br>Devicenet adapter for communications with the Unidrive SP  |
|            |  | Dark Grey   | SM-INTERBUS          | <b>Interbus option</b><br>Interbus adapter for communications with the Unidrive SP  |
|            |  | Pink        | SM-CAN               | <b>CAN option</b><br>CAN adapter for communications with the Unidrive SP  |
|            |  | Light Grey  | SM-CANopen           | <b>CANopen option</b><br>CANopen adapter for communications with the Unidrive SP  |
|            |  | Red         | SM-SERCOS            | <b>SERCOS option</b><br>Class B compliant. Torque velocity and position control modes supported with data rates (bit/sec): 2MB, 4MB, 8MB and 16MB. Minimum 250µsec network cycle time. Two digital high speed probe inputs 1µsec for position capture   |
|            |  | Beige       | SM-Ethernet          | <b>Ethernet option</b><br>10 base-T / 100 base-T; Supports web pages, SMTP mail and multiple protocols: DHCP IP addressing; Standard RJ45 connection  |

**Table 2-8 Solutions Module identification**

| Type | Solutions Module  | Colour | Name   | Further Details  |
|------|---|--------|--------|--|
| SLM  |  | Orange | SM-SLM | <b>SLM interface</b><br>The SM-SLM allows SLM feedback to be connected directly to the Unidrive SP drive and allows operation in either of the following modes: <ul style="list-style-type: none"> <li>Encoder only mode</li> <li>Host mode</li> </ul> |

**Table 2-9 Keypad identification**

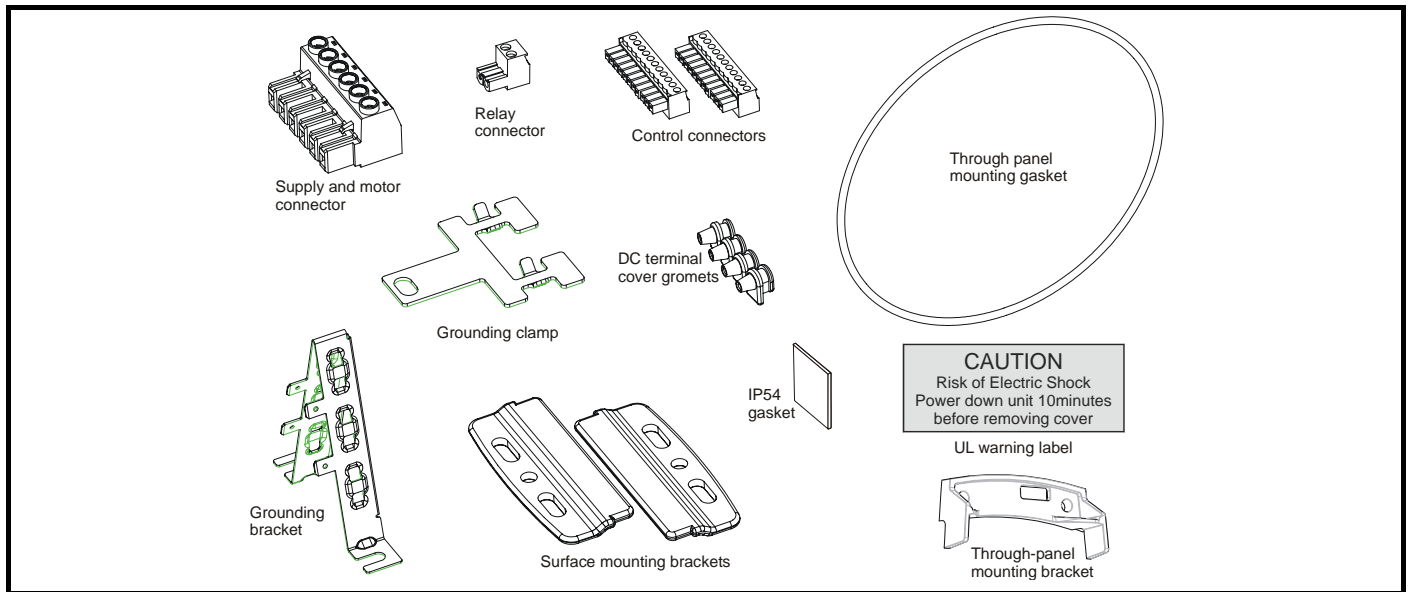
| Type   | Keypad  | Name           | Further Details   |
|--------|---|----------------|---|
| Keypad |  | SM-Keypad      | <b>LED keypad option</b><br>Keypad with a LED display                                   |
|        |  | SM-Keypad Plus | <b>LCD keypad option</b><br>Keypad with an alpha-numeric LCD display with Help function |

## 2.8 Items supplied with the drive

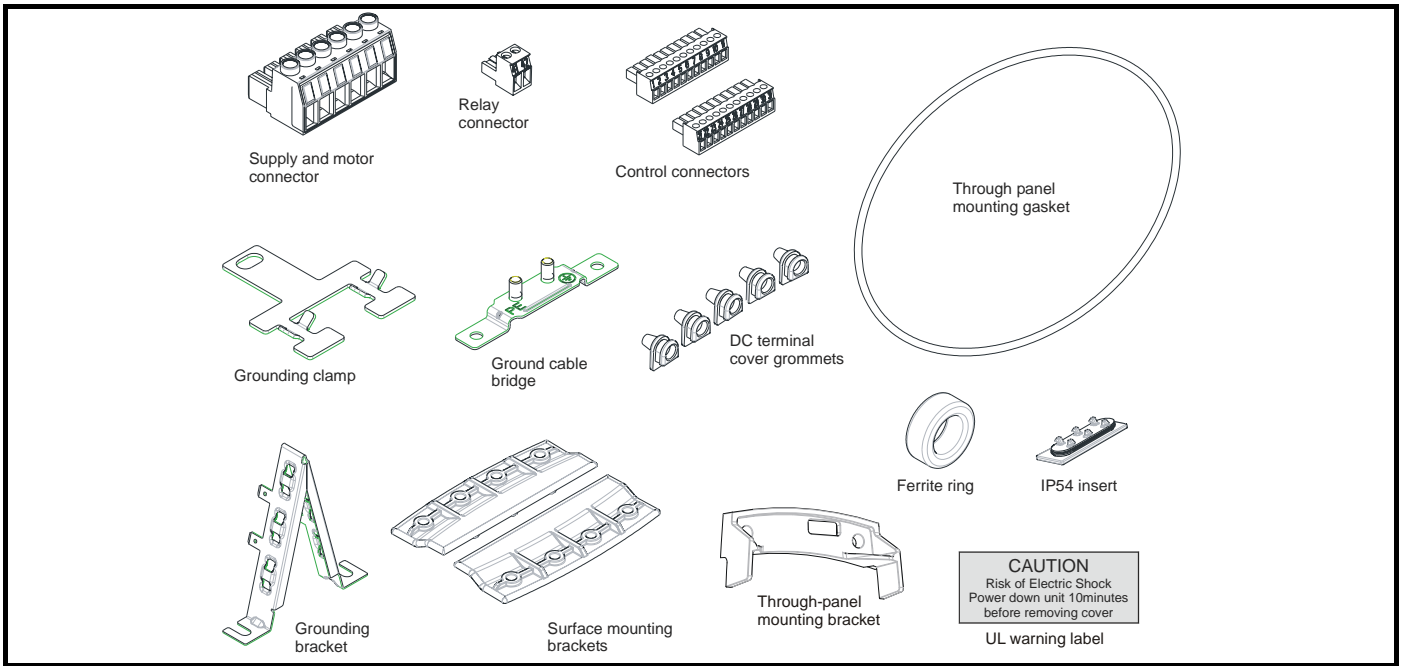
The drive is supplied with a copy of the multilingual *Unidrive SP Short Form Guide* (size 1 to 3) or *Unidrive SP User Guide* (size 4 and above), a SMARTCARD, the safety booklet, the certificate of quality, an accessory kit box including the items shown in Figure 2-5, Figure 2-6, Figure 2-7 or Figure 2-8, and a CD ROM containing the following user guides:

- *Unidrive SP User Guide (English, French, German, Italian, Spanish)*
- *Unidrive SP Advanced User Guide*
- *Solutions Module User Guides*

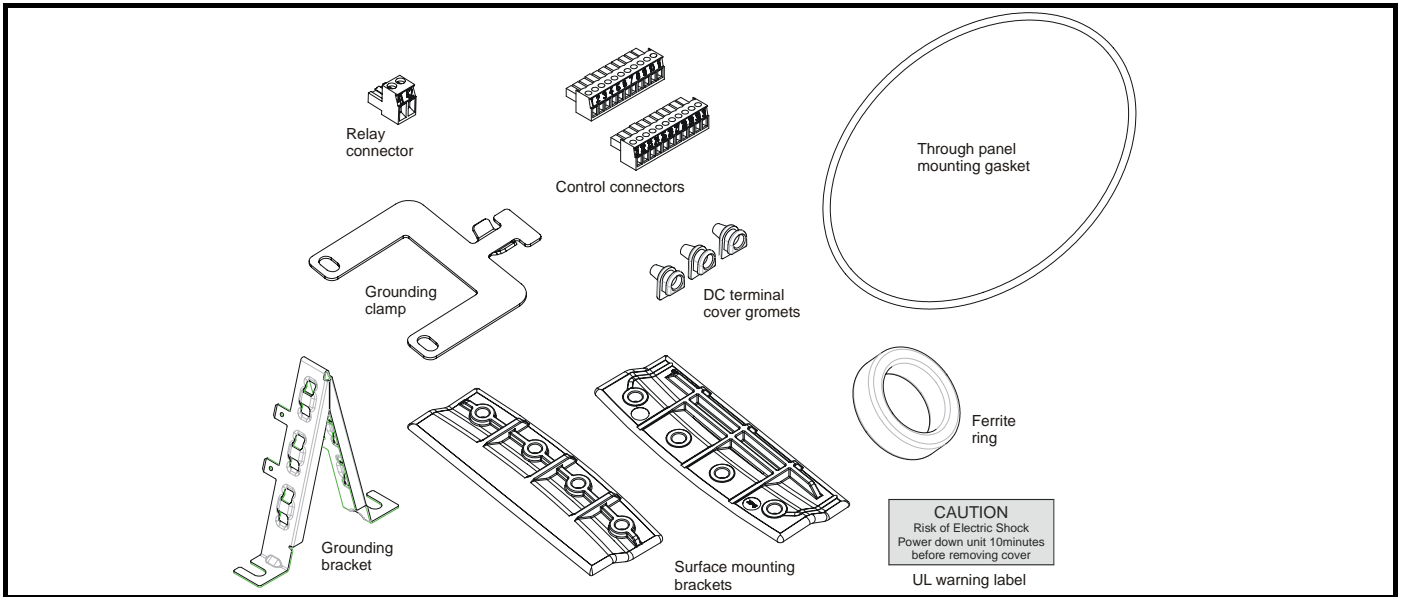
**Figure 2-5 Accessories supplied with size 1**



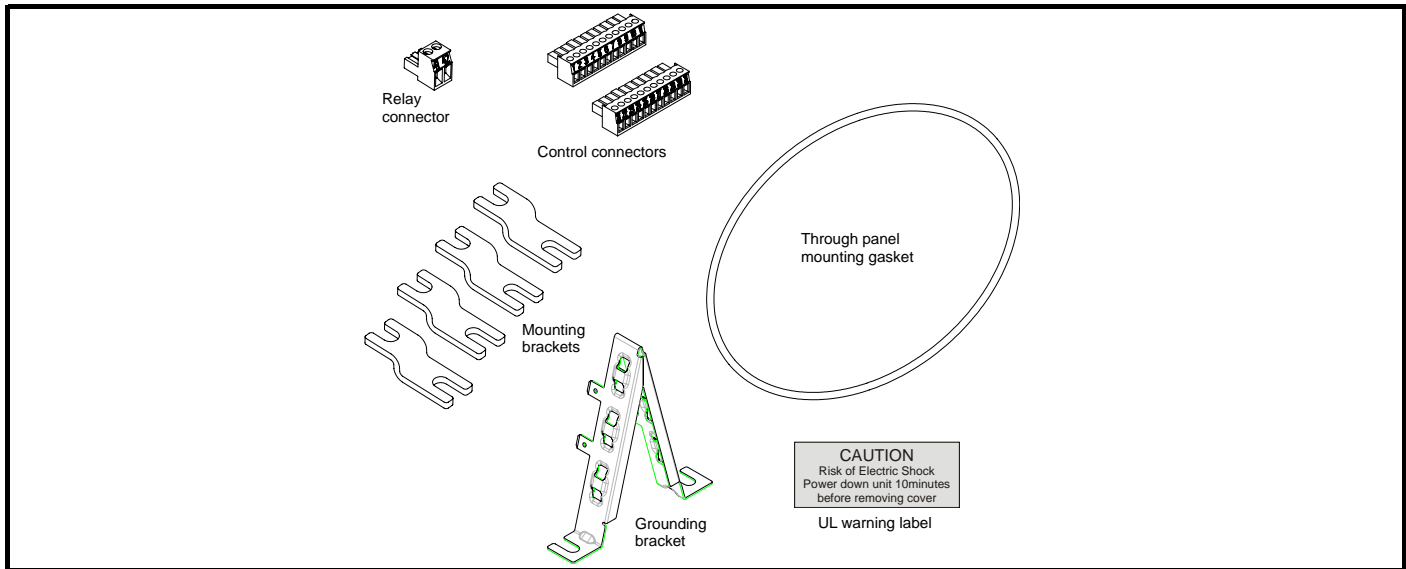
**Figure 2-6 Accessories supplied with size 2**



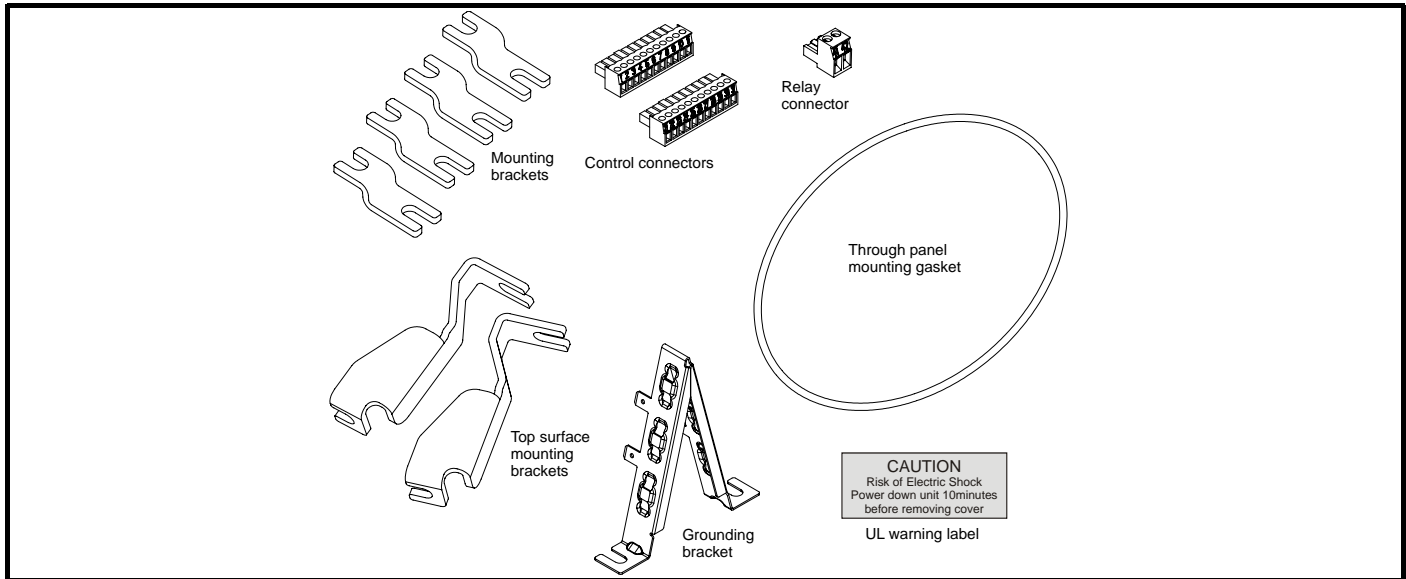
**Figure 2-7 Accessories supplied with size 3**



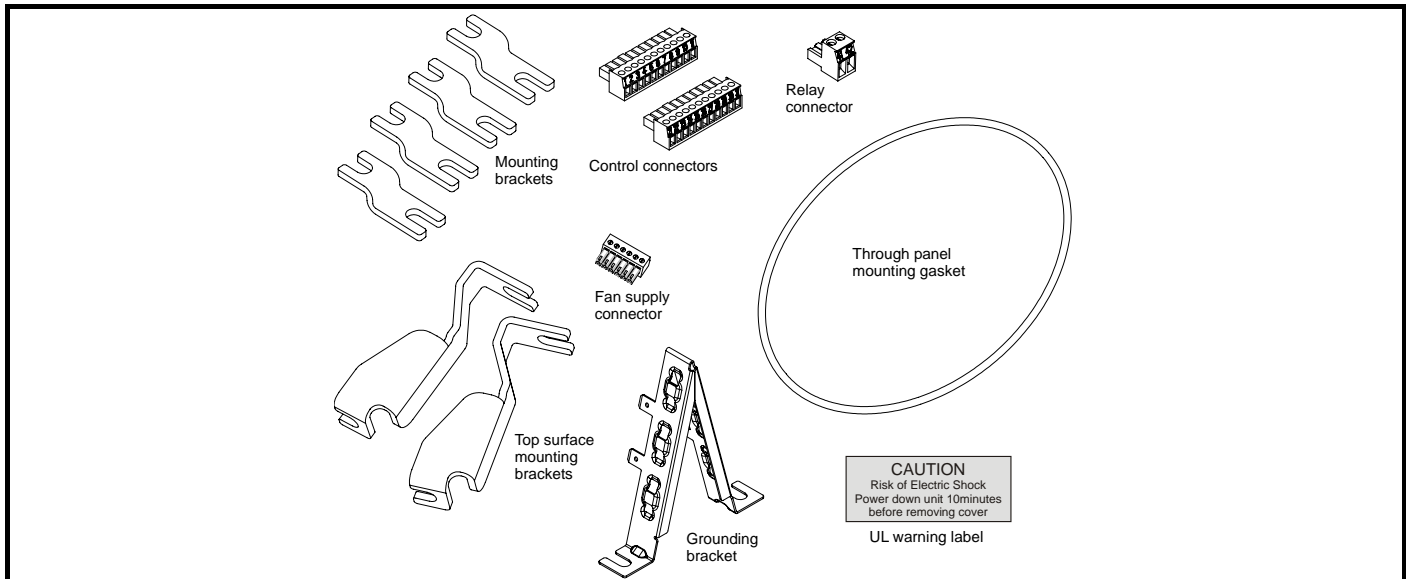
**Figure 2-8 Accessories supplied with size 4**



**Figure 2-9 Accessories supplied with size 5**



**Figure 2-10 Accessories supplied with size 6**



**NOTE** For cubicle drives, all accessories are fitted to the drive. Therefore, there is no separate kit box.

## 3 Mechanical Installation

This chapter describes how to use all mechanical details to install the drive. The drive is intended to be installed in an enclosure. Key features of this chapter include:

- Through-hole mounting
- IP54 as standard
- Enclosure sizing and layout
- Solutions Module fitting
- Terminal location and torque settings

### 3.1 Safety information



**WARNING**

Follow the instructions

The mechanical and electrical installation instructions must be adhered to. Any questions or doubt should be referred to the supplier of the equipment. It is the responsibility of the owner or user to ensure that the installation of the drive and any external option unit, and the way in which they are operated and maintained, comply with the requirements of the Health and Safety at Work Act in the United Kingdom or applicable legislation and regulations and codes of practice in the country in which the equipment is used.



**WARNING**

Competence of the installer

The drive must be installed by professional assemblers who are familiar with the requirements for safety and EMC. The assembler is responsible for ensuring that the end product or system complies with all the relevant laws in the country where it is to be used.



**WARNING**

The weights of the size 4, 5 and 6 drives are as follows:

- Size 4: 30 kg (66 lb)
- Size 5: 55 kg (121 lb)
- Size 6: 75 kg (165 lb)

Use appropriate safeguards when lifting these models



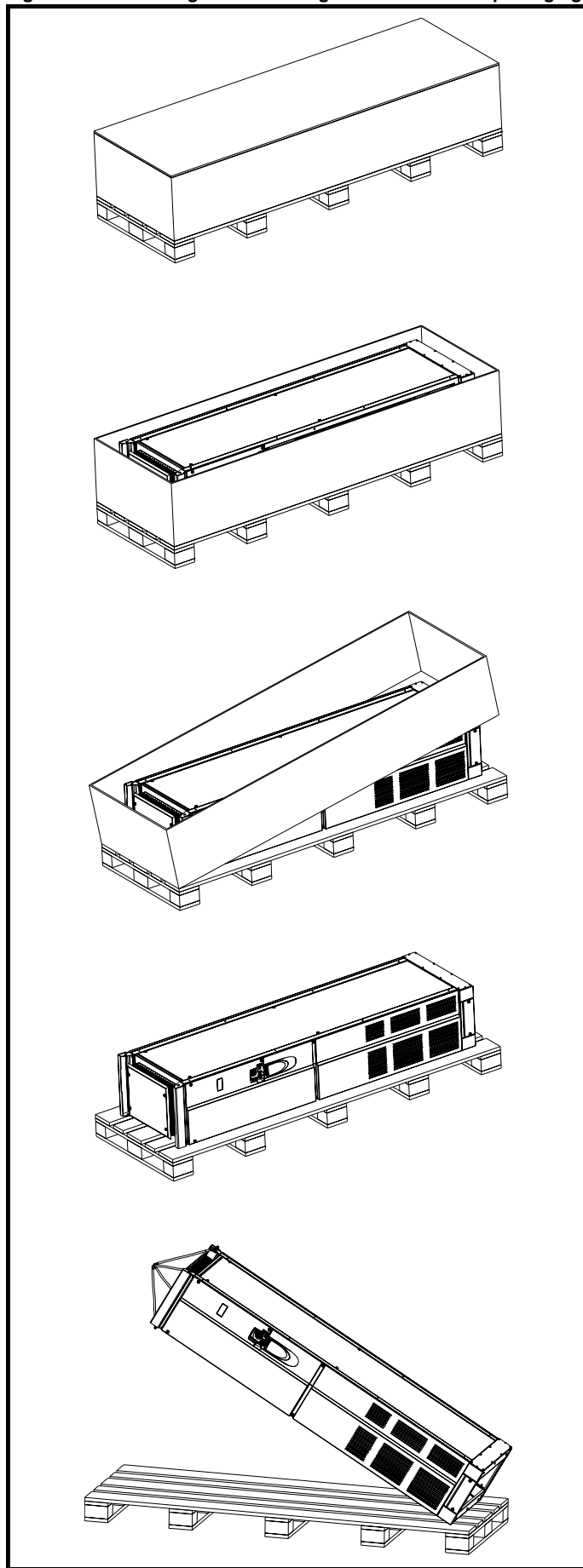
**WARNING**

The weights of the size 8 and 9 free standing drives are as follows:

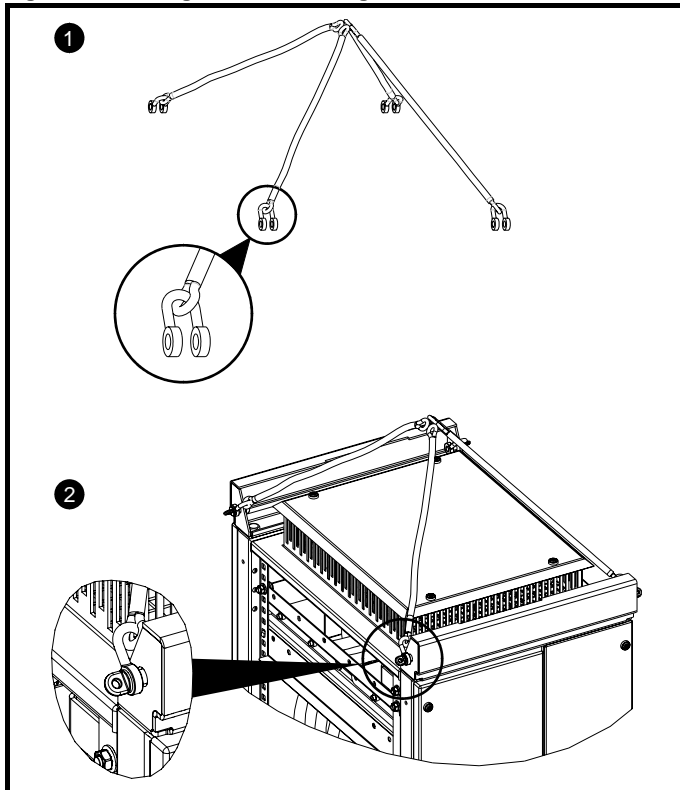
- Size 8: 266 kg (586 lb)
- Size 9: 532 kg (1173 lb)

Lift the drive by the method detailed in Figure 3-2 on page 26. Do not tilt the drive. The centre of gravity of the unit is high. An overturning unit can cause physical injury.

Figure 3-1 Removing a free standing cubicle drive from packaging



**Figure 3-2 Lifting the free standing cubicle drive**



1. Attach "D" shackles to each rope
2. Attach each shackle to the lifting plate. Ensure angle of each rope is  $>45^\circ$ .

## 3.2 Planning the installation

The following considerations must be made when planning the installation:

### 3.2.1 Access

Access must be restricted to authorised personnel only. Safety regulations which apply at the place of use must be complied with.

The IP (Ingress Protection) rating of the drive is installation dependent. For further information, please refer to section 3.11 *IP Rating (Ingress Protection)* on page 53.

### 3.2.2 Environmental protection

The drive must be protected from:

- moisture, including dripping water or spraying water and condensation. An anti-condensation heater may be required, which must be switched off when the drive is running.
- contamination with electrically conductive material
- contamination with any form of dust which may restrict the fan, or impair airflow over various components
- temperature beyond the specified operating and storage ranges
- corrosive gasses

### 3.2.3 Cooling

The heat produced by the drive must be removed without its specified operating temperature being exceeded. Note that a sealed enclosure gives much reduced cooling compared with a ventilated one, and may need to be larger and/or use internal air circulating fans.

For further information, please refer to section 3.8.2 *Enclosure sizing* on page 51.

### 3.2.4 Electrical safety

The installation must be safe under normal and fault conditions. Electrical installation instructions are given in Chapter 4 *Electrical Installation* on page 66.

### 3.2.5 Fire protection

The drive enclosure is not classified as a fire enclosure. A separate fire enclosure must be provided.

### 3.2.6 Electromagnetic compatibility

Variable speed drives are powerful electronic circuits which can cause electromagnetic interference if not installed correctly with careful attention to the layout of the wiring.

Some simple routine precautions can prevent disturbance to typical industrial control equipment.

If it is necessary to meet strict emission limits, or if it is known that electromagnetically sensitive equipment is located nearby, then full precautions must be observed. In-built into the drive, is an internal EMC filter, which reduces emissions under certain conditions. If these conditions are exceeded, then the use of an external EMC filter may be required at the drive inputs, which must be located very close to the drives. Space must be made available for the filters and allowance made for carefully segregated wiring. Both levels of precautions are covered in section 4.11 *EMC (Electromagnetic compatibility)* on page 82.

### 3.2.7 Hazardous areas

The drive must not be located in a classified hazardous area unless it is installed in an approved enclosure and the installation is certified.

## 3.3 Terminal cover removal



#### Isolation device

The AC supply must be disconnected from the drive using an approved isolation device before any cover is removed from the drive or before any servicing work is performed.



#### Stored charge

The drive contains capacitors that remain charged to a potentially lethal voltage after the AC supply has been disconnected. If the drive has been energised, the AC supply must be isolated at least ten minutes before work may continue.

Normally, the capacitors are discharged by an internal resistor. Under certain, unusual fault conditions, it is possible that the capacitors may fail to discharge, or be prevented from being discharged by a voltage applied to the output terminals. If the drive has failed in a manner that causes the display to go blank immediately, it is possible the capacitors will not be discharged. In this case, consult Control Techniques or their authorised distributor.

### 3.3.1 Removing the terminal covers

Unidrive SP size 1 is fitted with two terminal covers: Control and DC terminal covers.

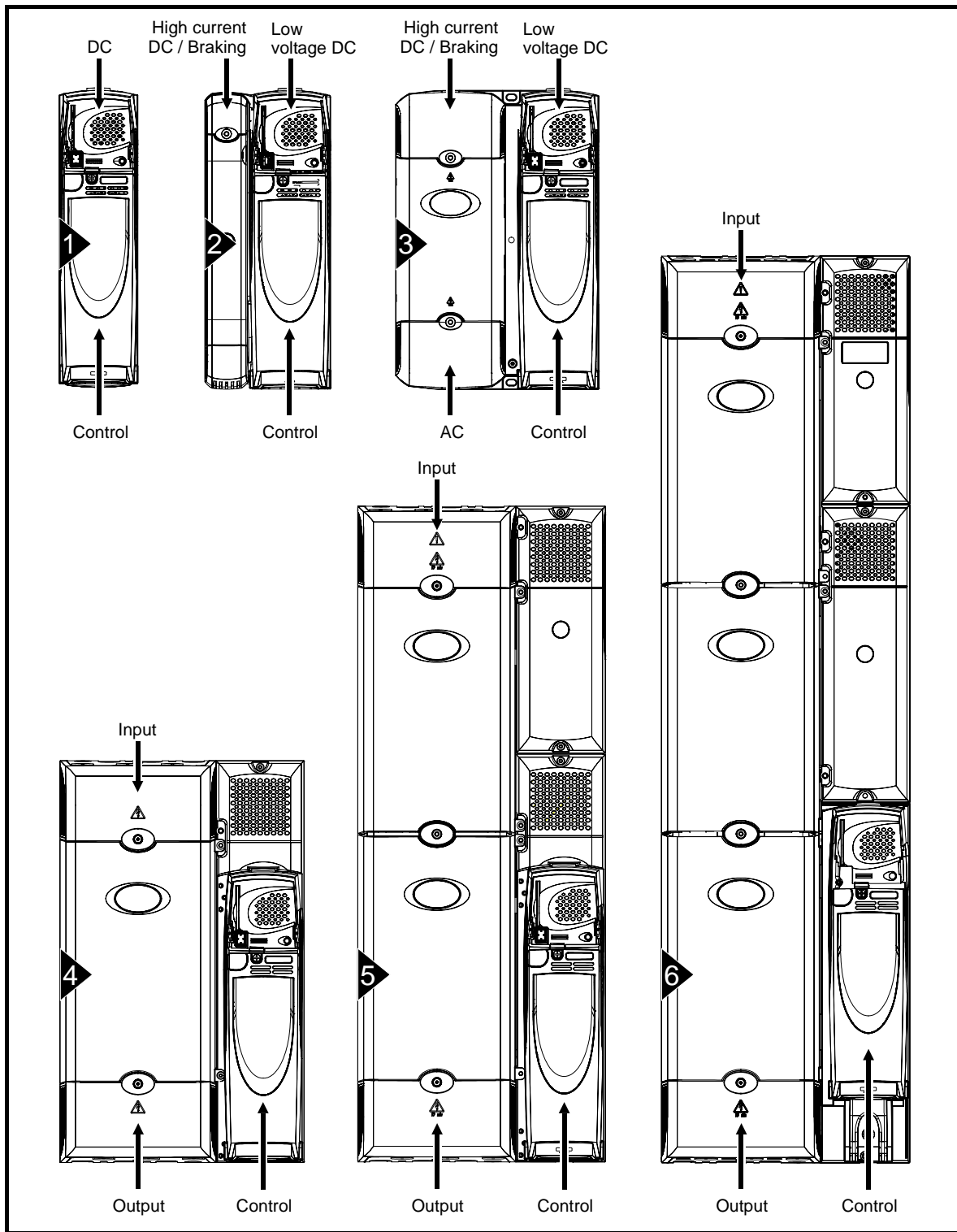
Unidrive SP size 2 is fitted with three terminal covers: Control, High current DC / Braking and low voltage DC terminal covers.

Unidrive SP size 3 is fitted with four terminal covers: Control, High current DC / Braking, low voltage DC and AC terminal covers.

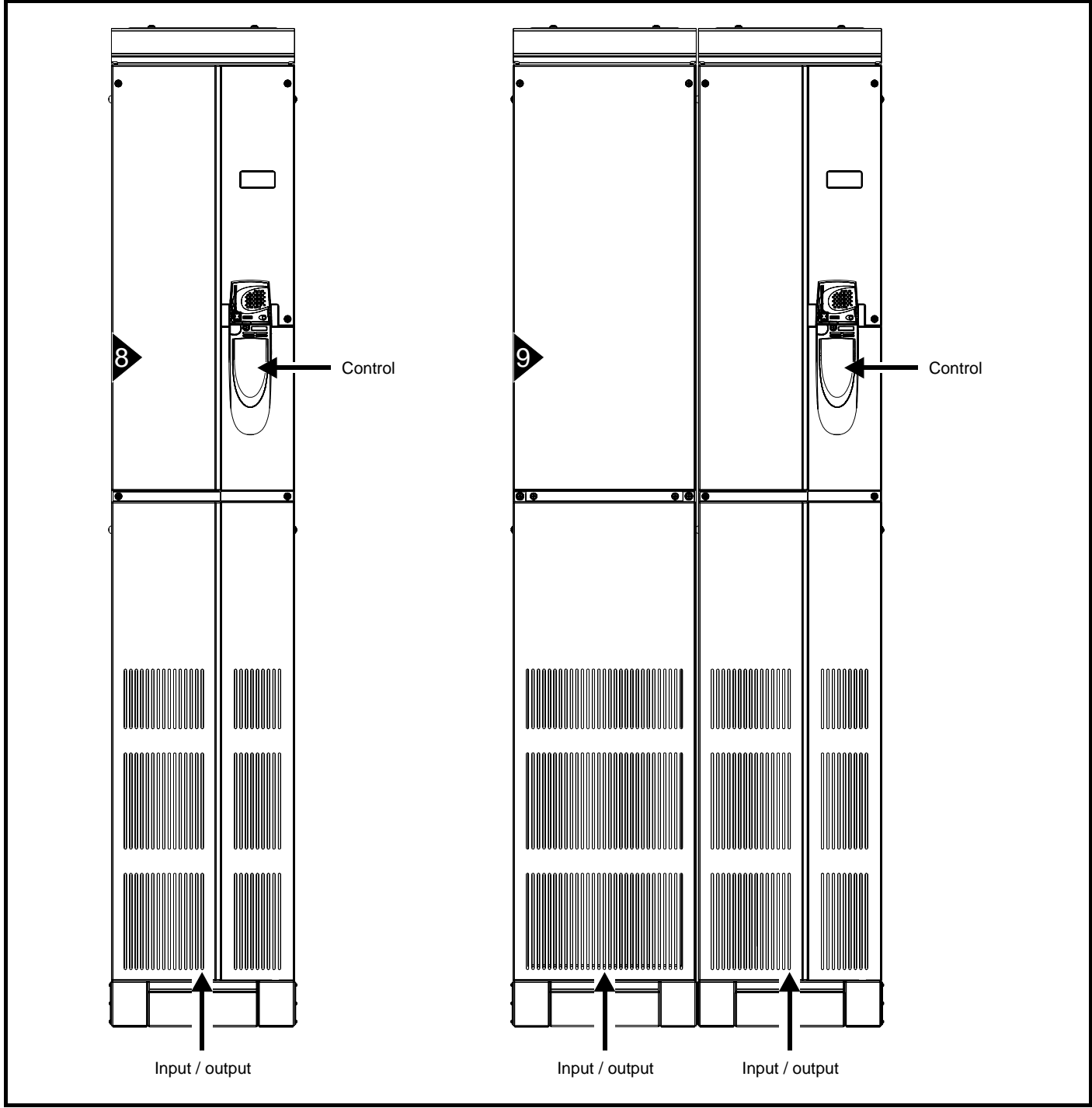
Unidrive SP size 4, 5 and 6 are fitted with three terminal covers: Control, input and output terminal covers.

When the drive is through-panel mounted the control, and AC for size 3, terminal cover must be removed in order to provide access to the mounting holes. Once the drive has been mounted, the terminal cover can be replaced.

**Figure 3-3 Location and identification of terminal covers**



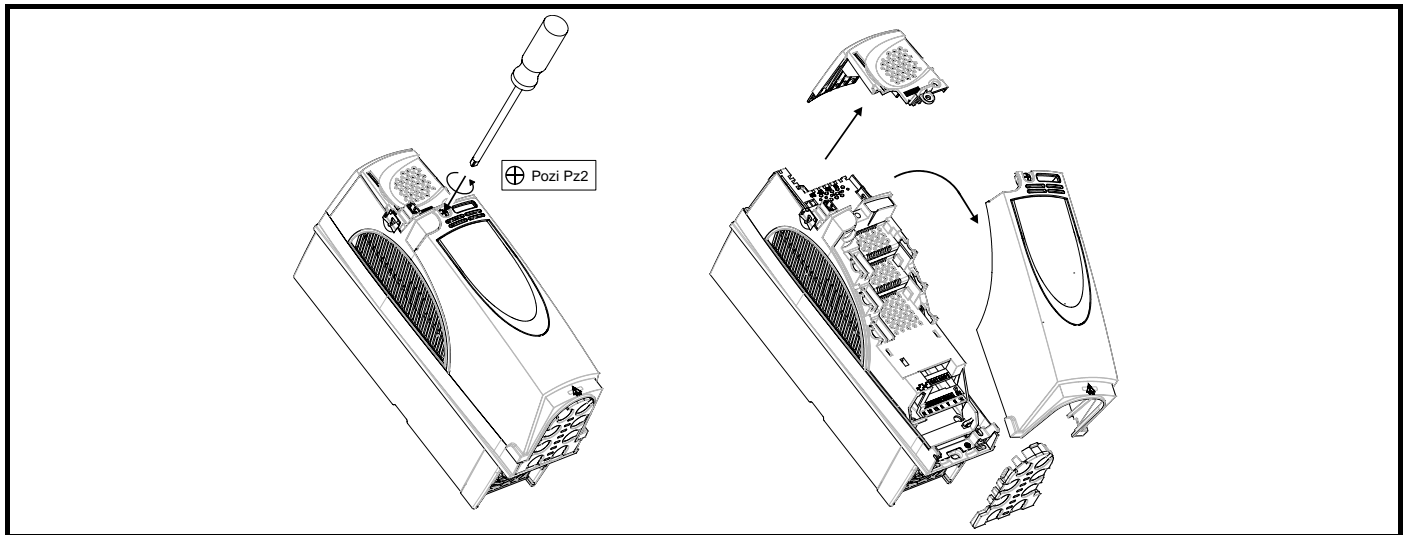
**Figure 3-4 Location and identification of terminal covers for free standing cubicle drives**



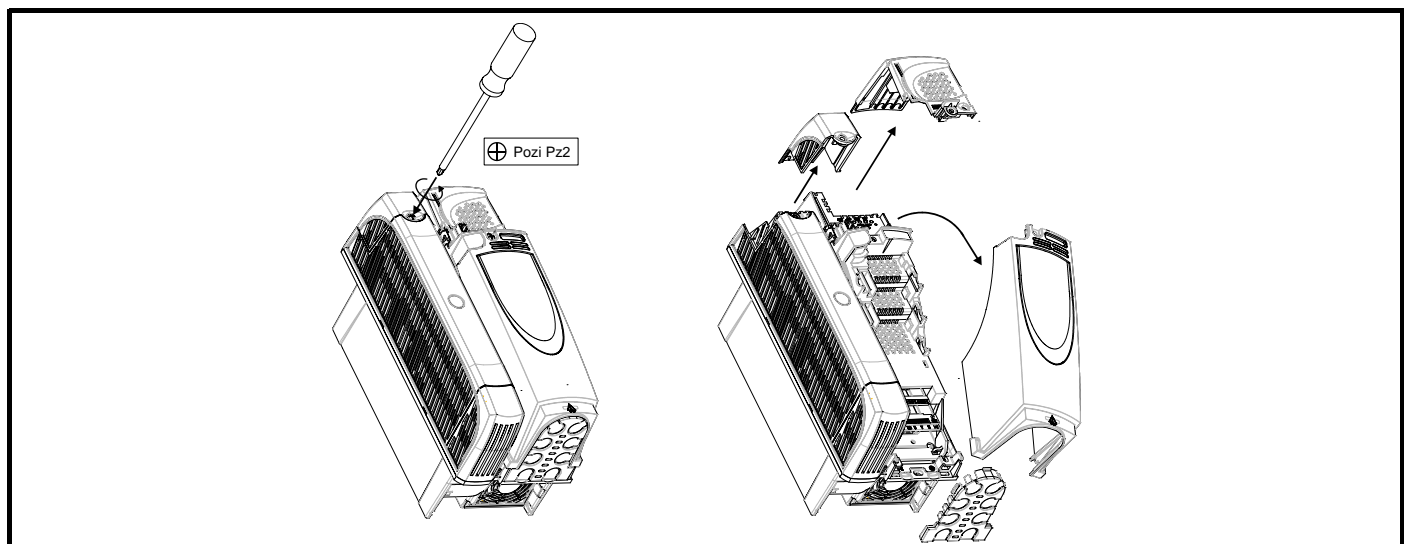
To remove a terminal cover, undo the screw and lift the terminal cover off as shown. The control terminal cover must be removed first before the DC (size 1) / low voltage DC (sizes 2 and 3) terminal cover can be removed.

When replacing the terminal covers the screws should be tightened with a maximum torque of 1 N m (0.7 lb ft).

**Figure 3-5 Removing the size 1 terminal covers**



**Figure 3-6 Removing the size 2 terminal covers**



**Figure 3-7 Removing the size 3 terminal covers**

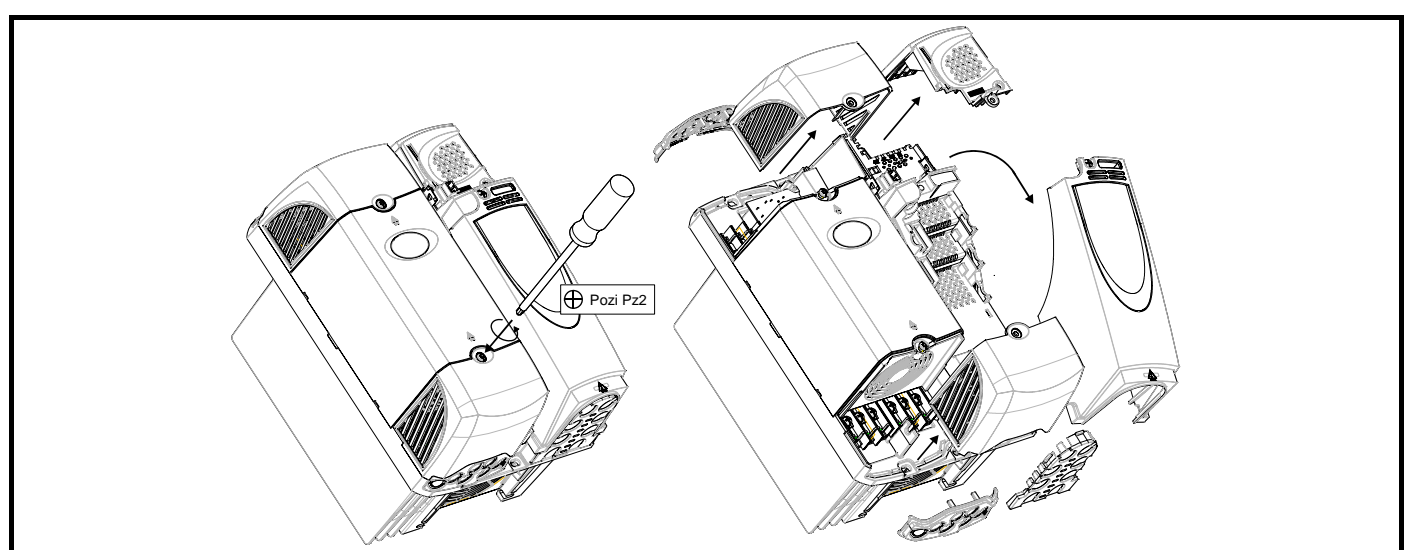


Figure 3-8 Removing the size 4, 5 and 6 terminal covers (size 4 illustrated)

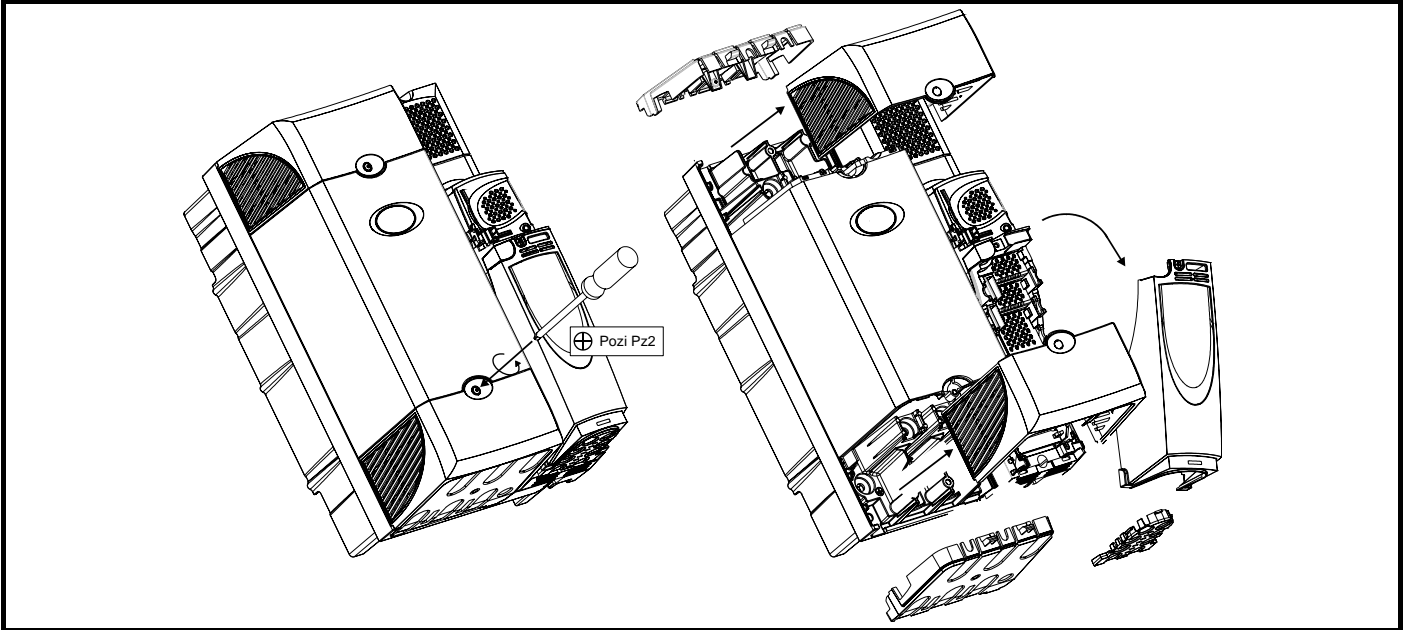


Figure 3-9 Removing the size 8 terminal covers from the free standing cubicle drive

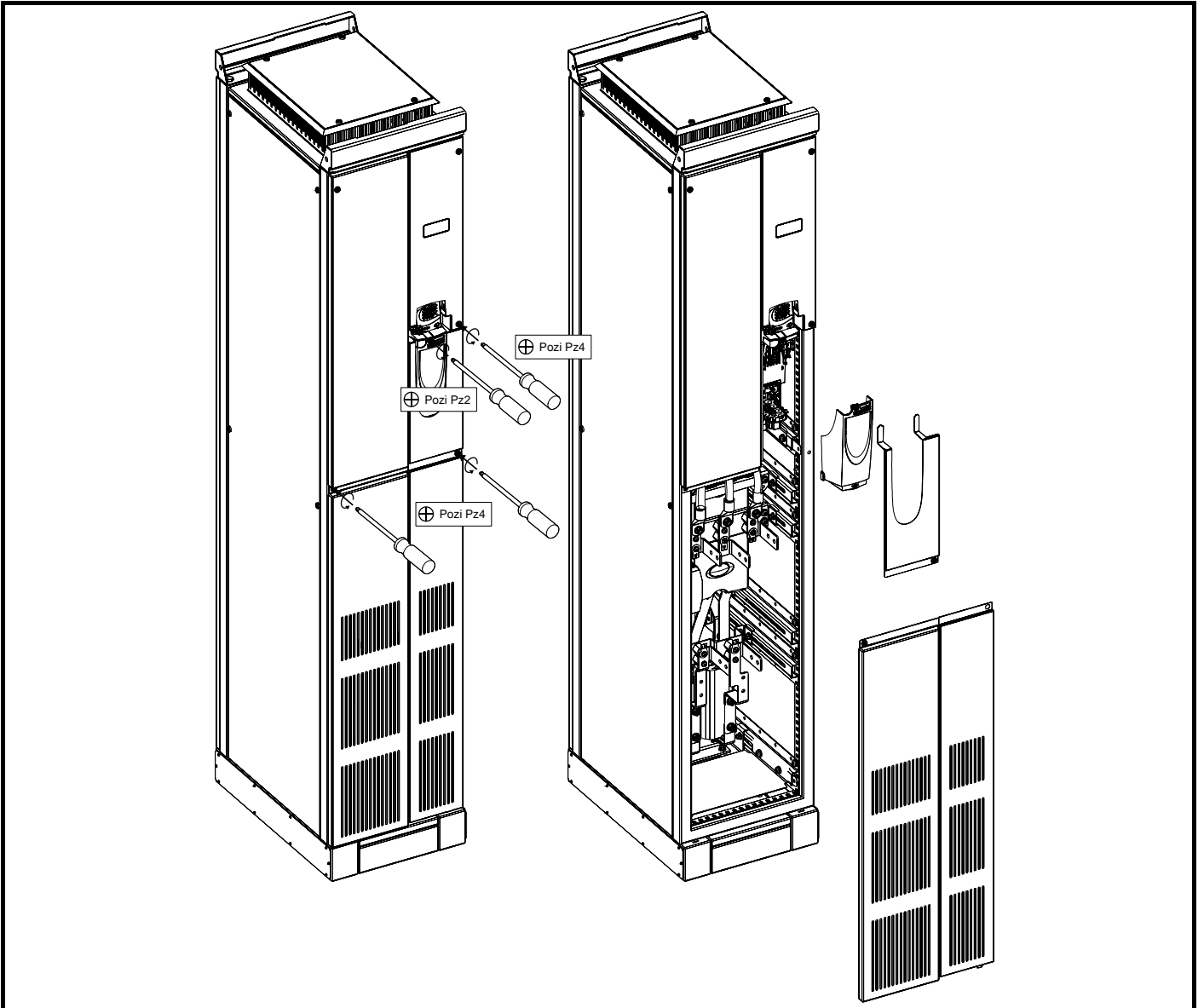
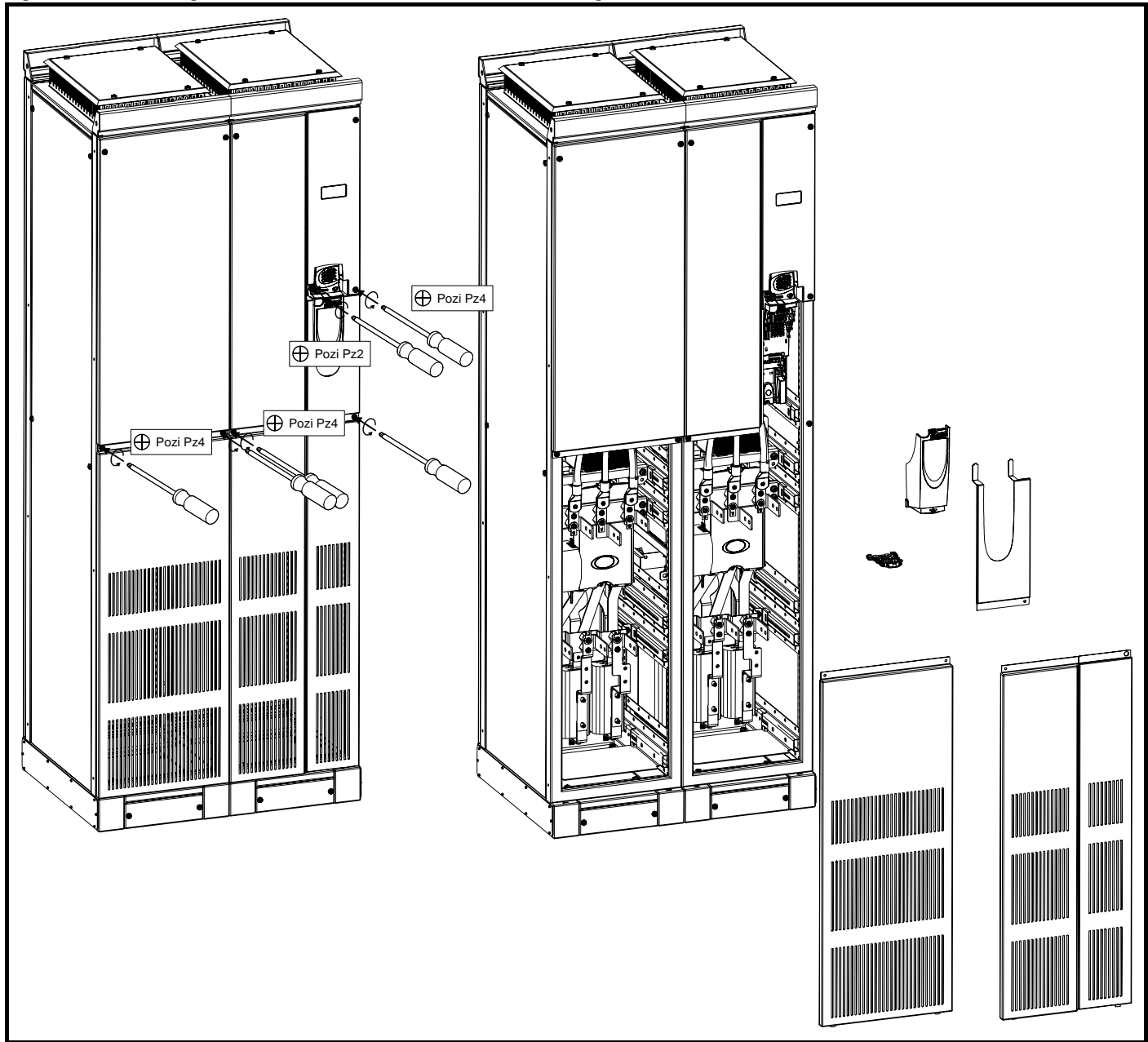


Figure 3-10 Removing the size 9 terminal covers from the free standing cubicle drive



### 3.4 Baying free standing cubicles

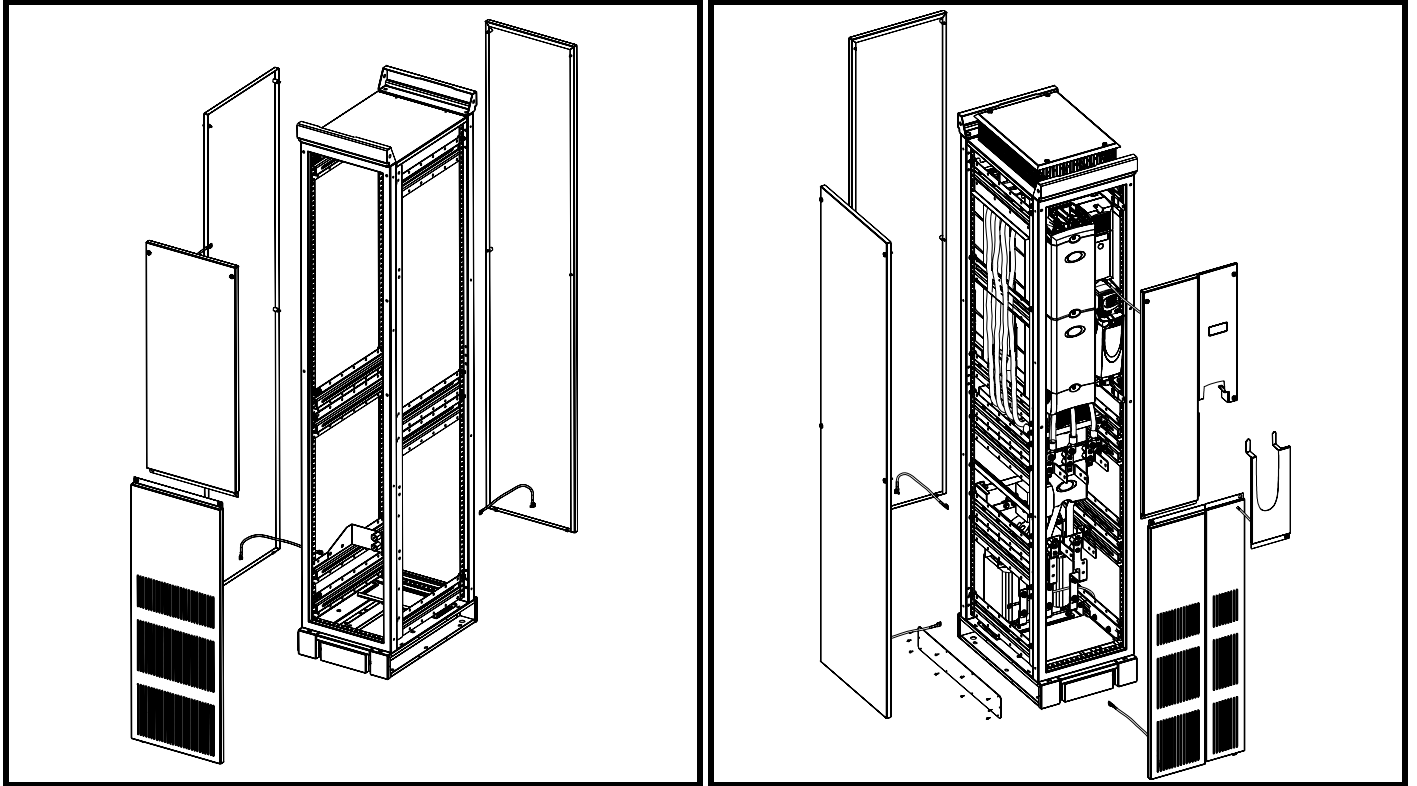
This section describes how to connect or 'bay' the various free standing cubicles together.

#### 3.4.1 Preparation for baying

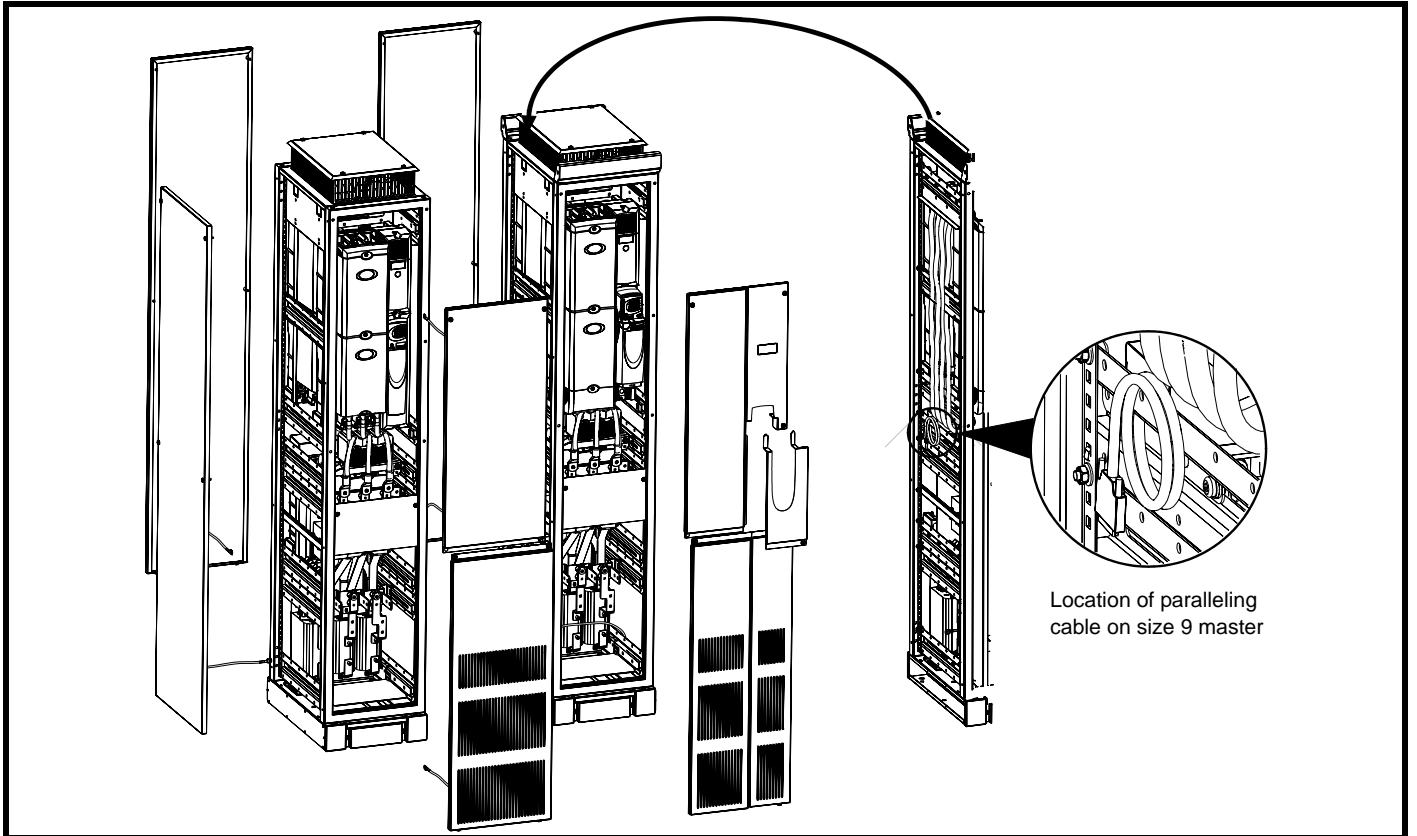
The following diagrams show how to prepare the incomer shell/applications cubicle, the size 8 and size 9 free standing cubicle drives for baying.

1. Remove all front and side panels as shown. All screws for these are Pozi Pz4
2. All ground cable connections are to be removed with an M8 Torx head (T40)

**Figure 3-11** Preparation for baying the incomer / applications cubicle **Figure 3-12** Preparation for baying the size 8 free standing drive



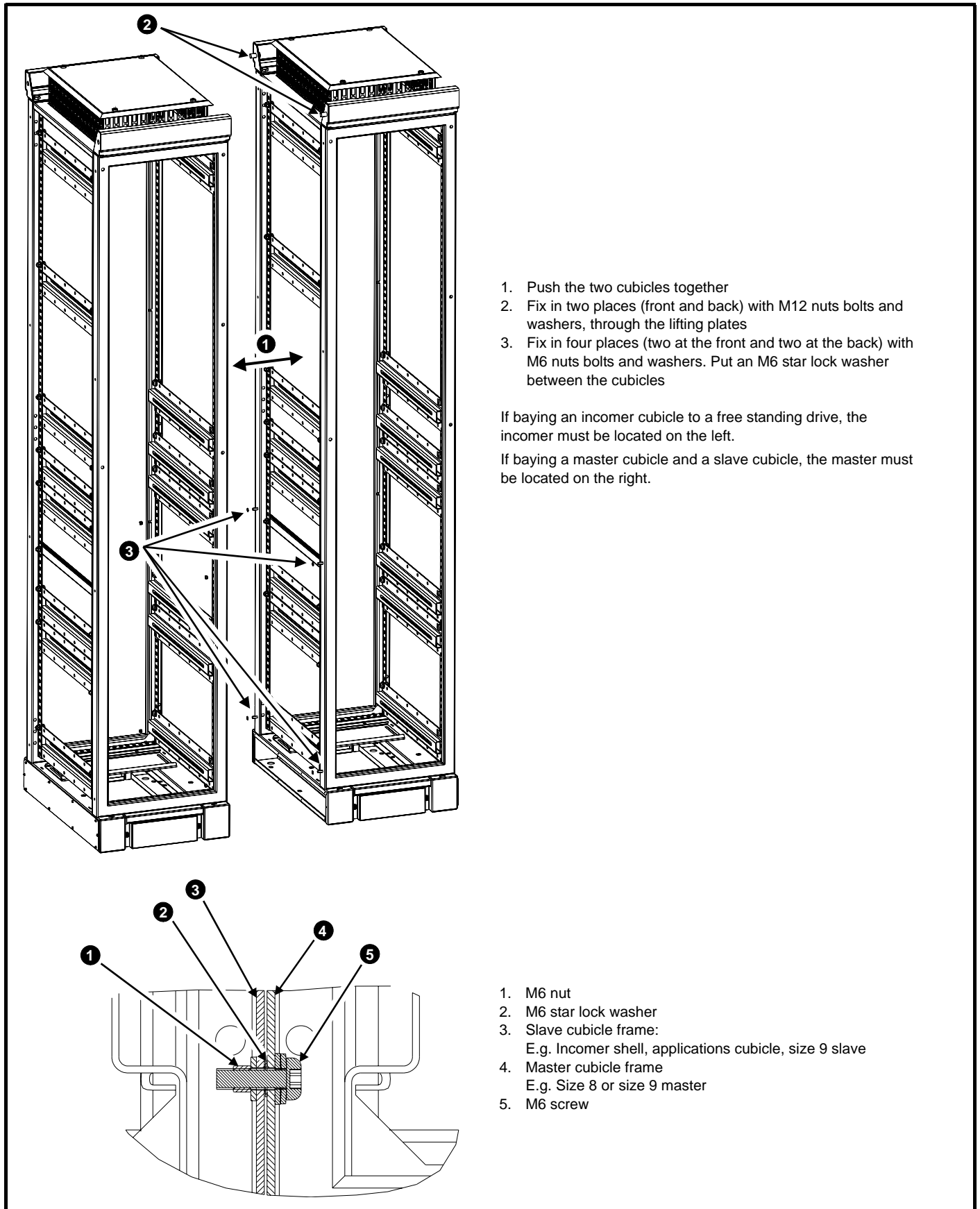
**Figure 3-13** Preparation for baying the size 9 free standing drive (slave and master)



### 3.4.2 Baying of cubicles

The following generic drawing demonstrates how to bay any type of cubicle together.

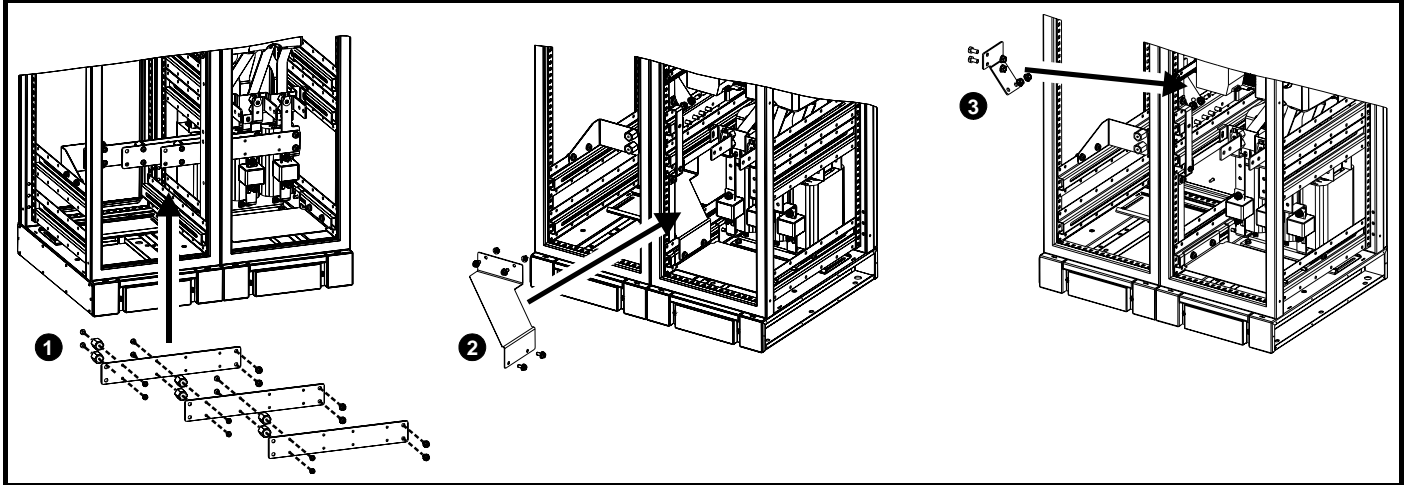
Figure 3-14 Baying of cubicles



### 3.4.3 Variant dependant connections

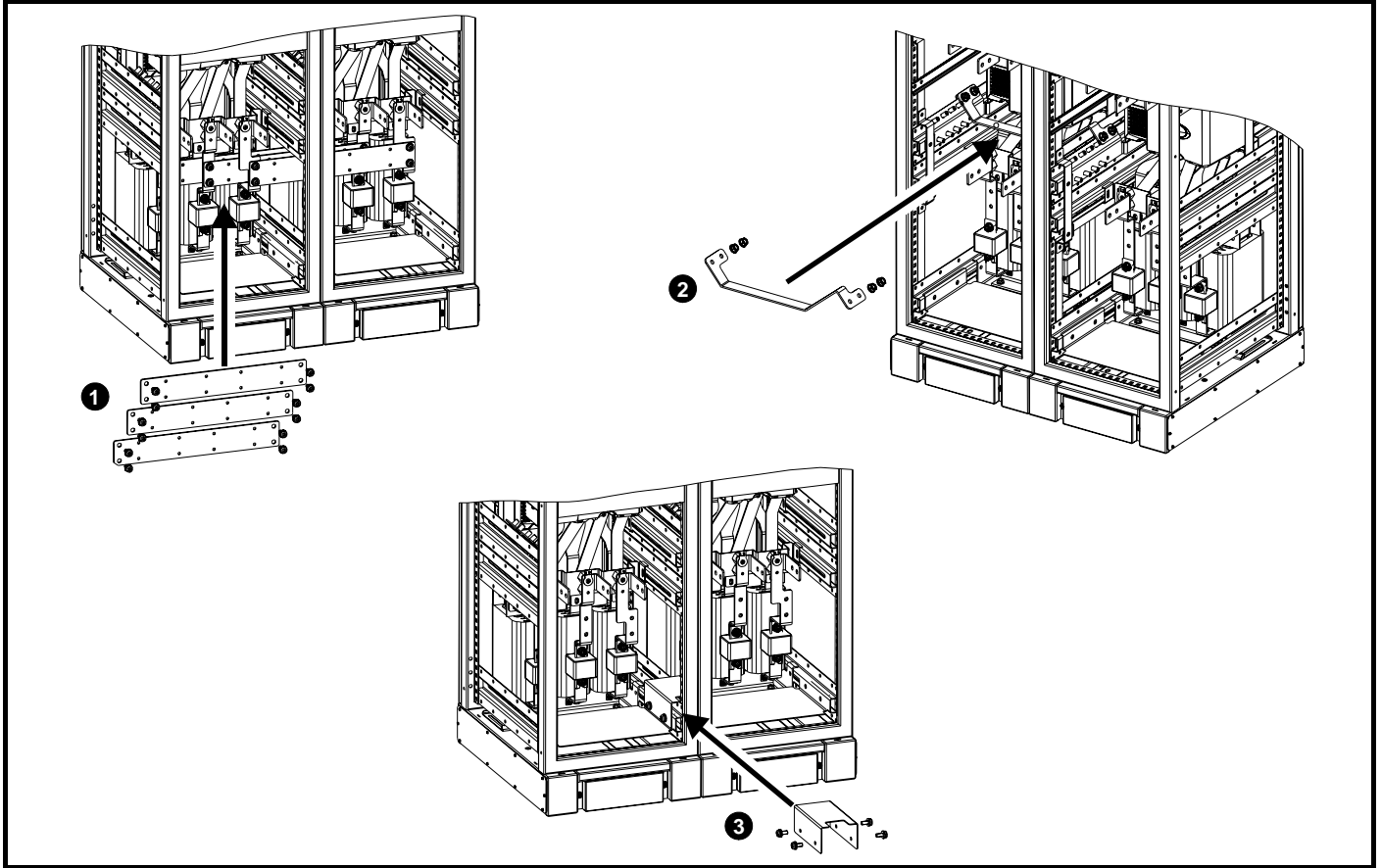
The following diagrams look at specific features of baying. All images show the appropriate components exploded and fitted.

**Figure 3-15 Baying the incomer shell / applications cubicle to a free standing cubicle drive**



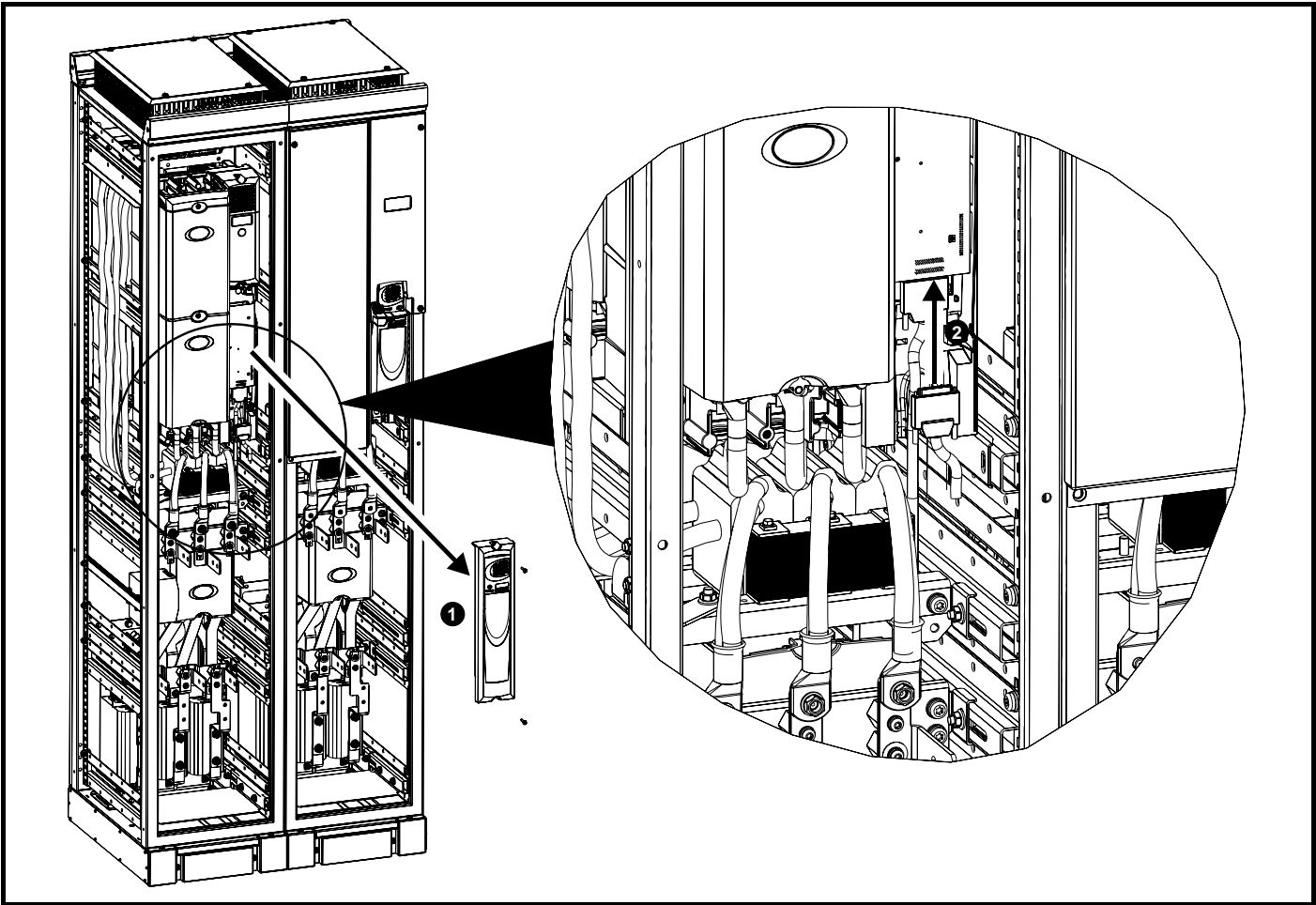
1. Fit paralleling busbars from incomer to the free standing cubicle drive input terminals and fix with M8 screws (17 N m, 12.5 lb.ft)
2. Fit EMC bracket when EMC filter required
3. Fit ground clamp

**Figure 3-16 Baying the size 9 master and slave**



1. Fit paralleling busbars from the slave to the master free standing cubicle drive input terminals and fix with M8 screws (17 N m, 12.5 lb.ft) if used on common supply source
2. Fit ground clamp
3. Fit EMC bracket

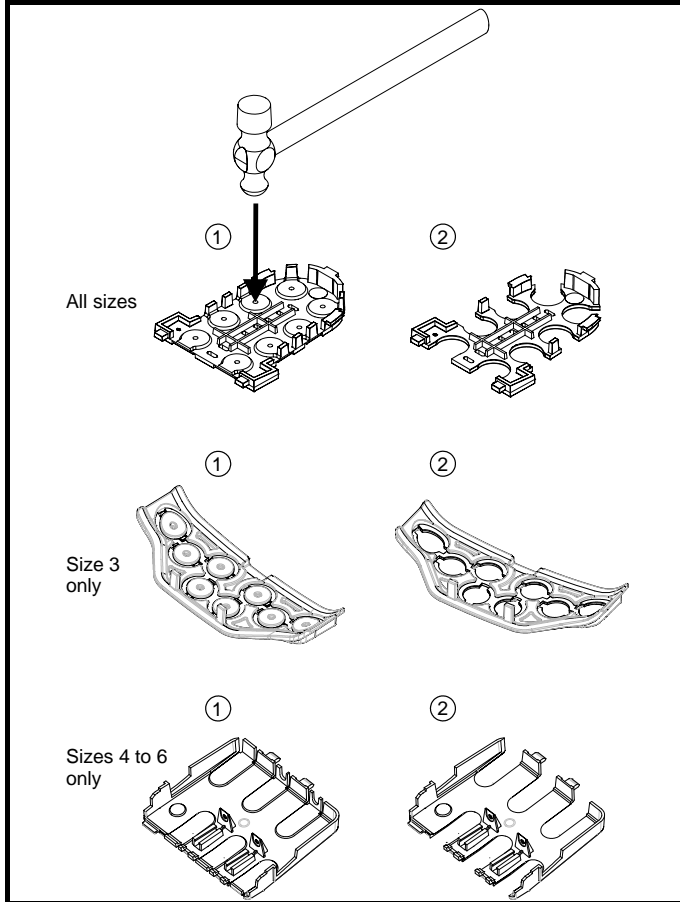
Figure 3-17 Fitting the parallel cable from a size 9 master to slave



1. Remove size 9 slave interface cover
2. Connect the paralleling cable to the size 9 slave input slot
3. Replace size 9 slave interface cover
4. Replace all size 9 cubicle panels

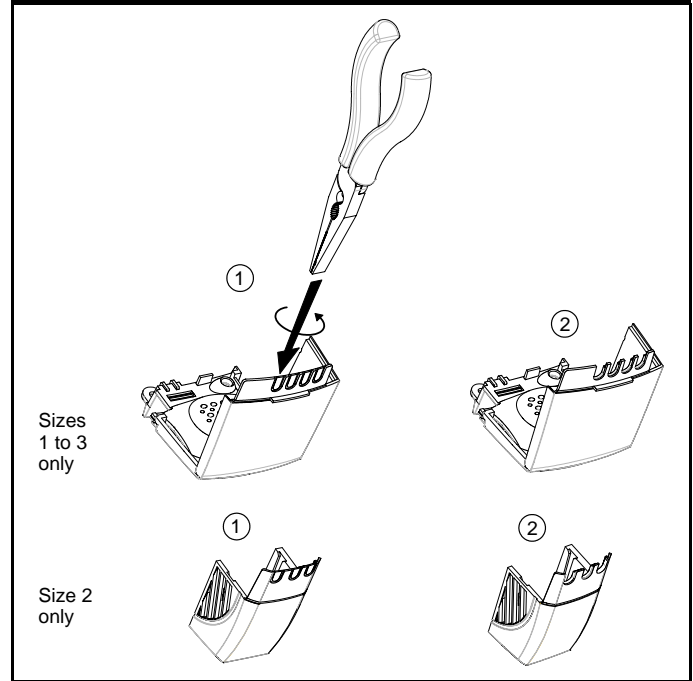
### 3.4.4 Removing the finger-guard and DC terminal cover break-outs

**Figure 3-18 Removing the finger-guard break-outs**



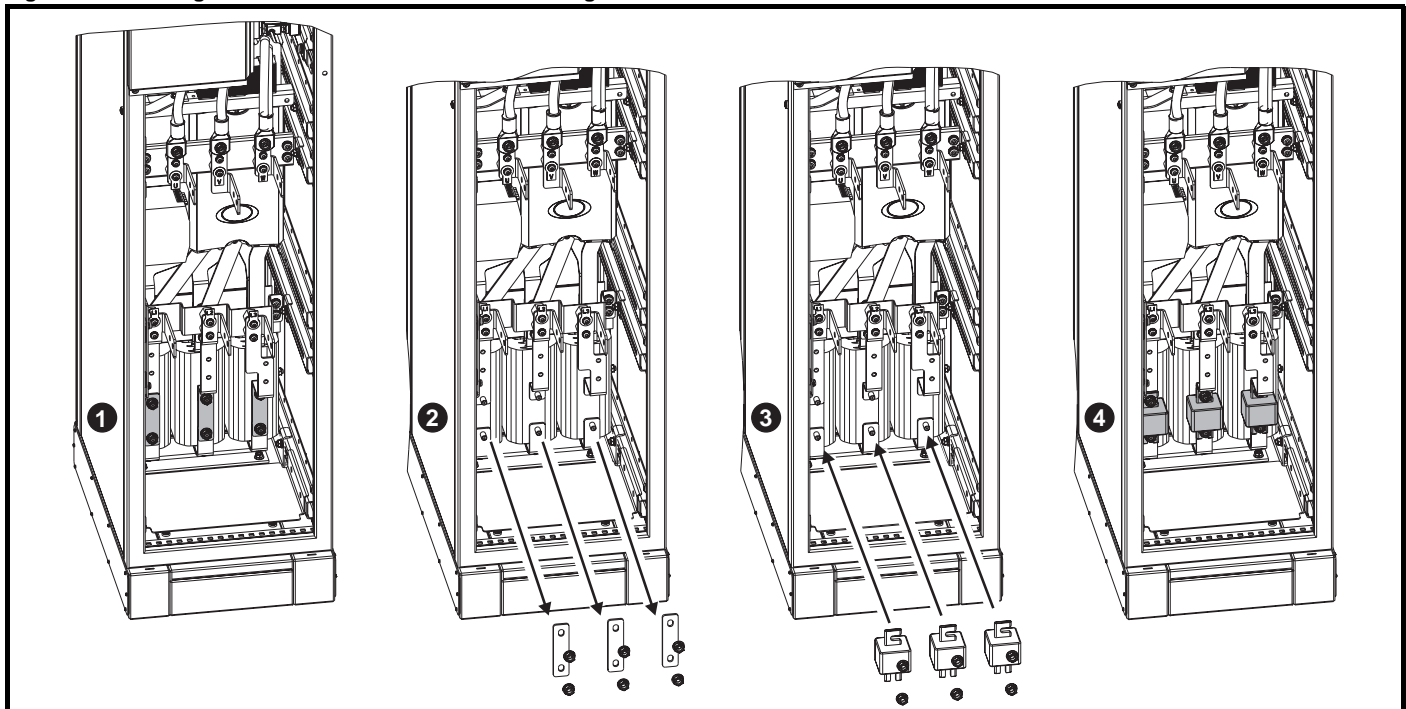
Place finger-guard on a flat solid surface and hit relevant break-outs with hammer as shown (1). Continue until all required break-outs are removed (2). Remove any flash / sharp edges once the break-outs are removed.

**Figure 3-19 Removing the DC terminal cover break-outs**



Grasp the DC terminal cover break-outs with pliers as shown (1) and twist to remove. Continue until all required break-outs are removed (2). Remove any flash / sharp edges once the break-outs are removed. Use the DC terminal cover grommets supplied in the accessory box (Figure 2-5 and Figure 2-6 on page 23, and Figure 2-7 and Figure 2-8 on page 24) to maintain the seal at the top of the drive.

**Figure 3-20 Fitting fuses to the size 8 and 9 free standing cubicle drives**



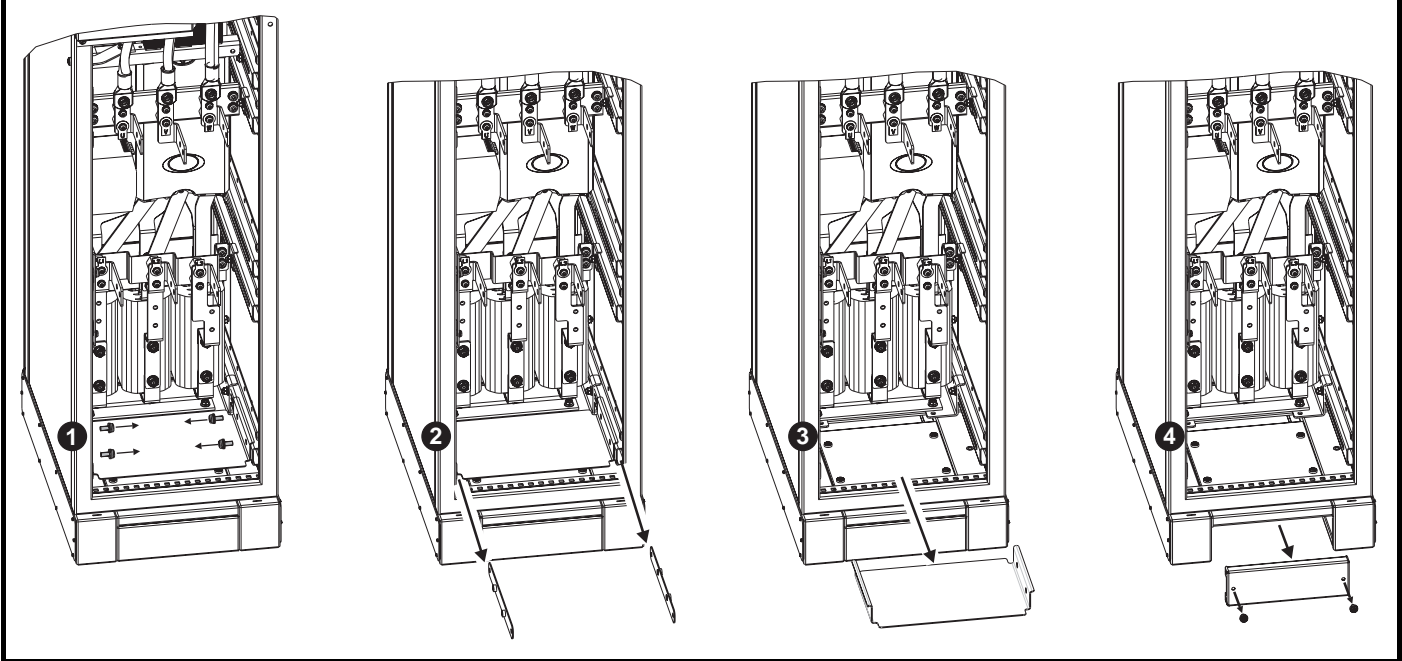
Fuses must be fitted. These can be purchased from Control Techniques. See Table 4-6 on page 77 for further information. The nuts holding the fuses must be tightened to a torque of 12N m (8.8lb.ft)




Ensure fuses are aligned with the busbar.

**CAUTION**

**Figure 3-21 Removing the cable gland plate from the size 8 and 9 free standing cubicle drive for “glanding off” the cable**



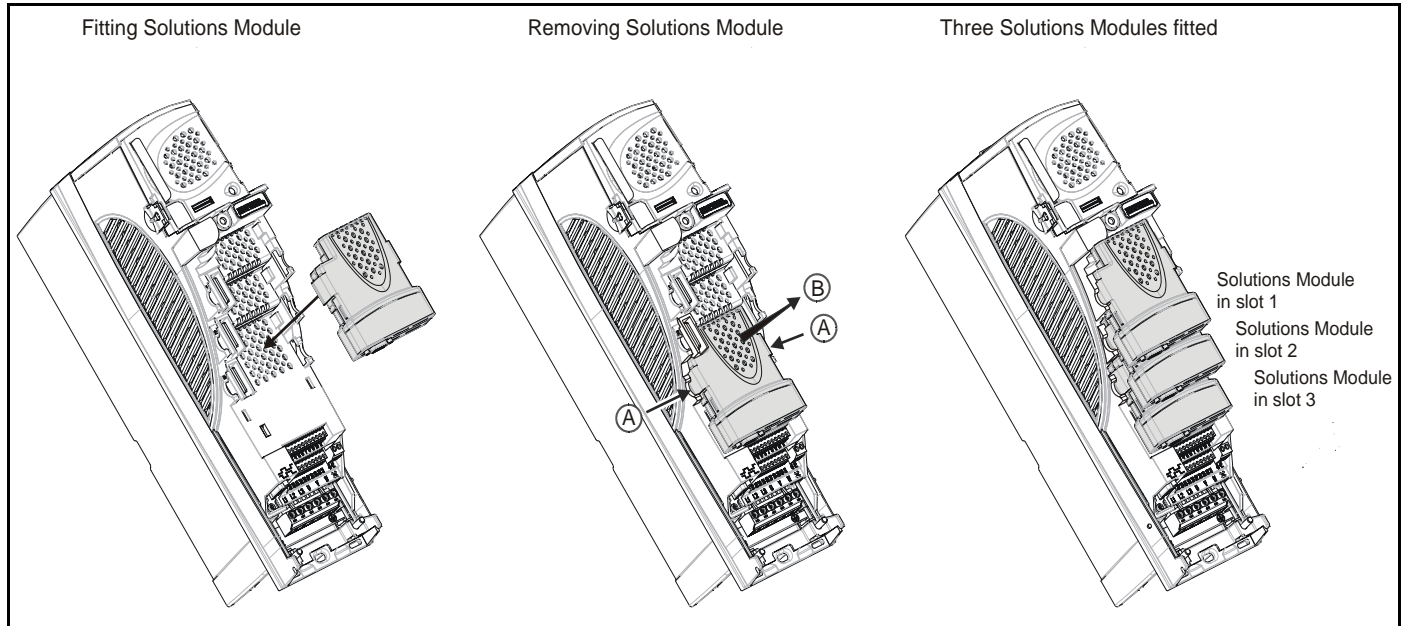
### 3.5 Solutions Module fitting / removal



Power down the drive before fitting / removing the Solutions Module. Failure to do so may result in damage to the product.

**CAUTION**

**Figure 3-22 Fitting and removal of a Solutions Module**



To fit the Solutions Module, press down in the direction shown above until it clicks into place.

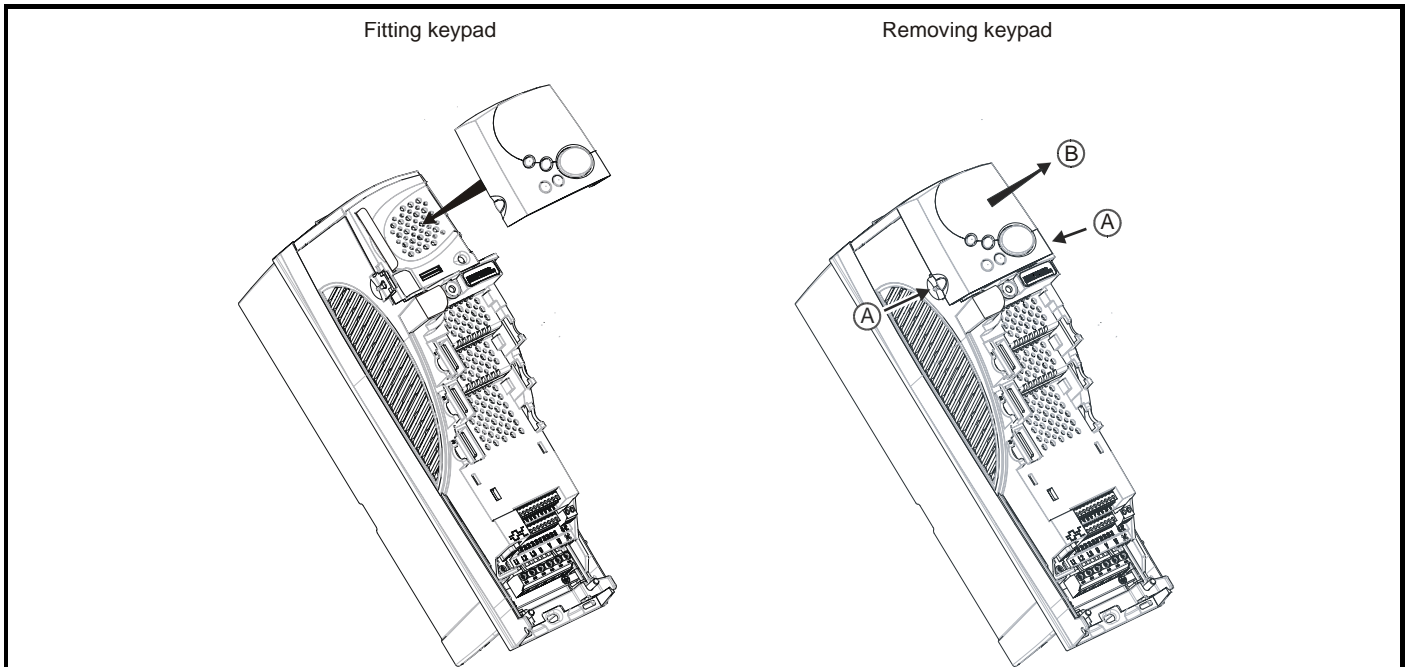
To remove the Solutions Module, press inwards at the points shown (A) and pull in the direction shown (B).

The drive has the facility for all three Solutions Module slots to be used at the same time, as illustrated.

**NOTE**

It is recommended that the Solutions Module slots are used in the following order: slot 3, slot 2 and slot 1.

**Figure 3-23 Fitting and removal of a keypad**



To fit, align the keypad and press gently in the direction shown until it clicks into position.

To remove, whilst pressing the tabs inwards (A), gently lift the keypad in the direction indicated (B).

**NOTE**

The keypad can be fitted / removed whilst the drive is powered up and running a motor, providing that the drive is not operating in keypad mode.

### 3.6 Mounting methods

Unidrive SP can be either surface or through-panel mounted using the appropriate brackets.

The following drawings show the dimensions of the drive and mounting holes for each method to allow a back plate to be prepared.



If the drive has been used at high load levels for a period of time, the heatsink can reach temperatures in excess of 70°C (158°F). Human contact with the heatsink should be prevented.



The weights of the size 4, 5 and 6 drives are as follows:

Size 4: 30 kg (66 lb)

Size 5: 55 kg (121 lb)

Size 6: 75 kg (165 lb)

Use appropriate safeguards when lifting these models



The weights of the size 8 and 9 free standing drives are as follows:

Size 8: 266 kg (586 lb)

Size 9: 532 kg (1173 lb)

Lift the drive by the method detailed in Figure 3-2 on page 26. Do not tilt the drive. The centre of gravity of the unit is high. An overturning unit can cause physical injury.

#### 3.6.1 Surface mounting

Figure 3-24 Surface mounting the size 1 drive

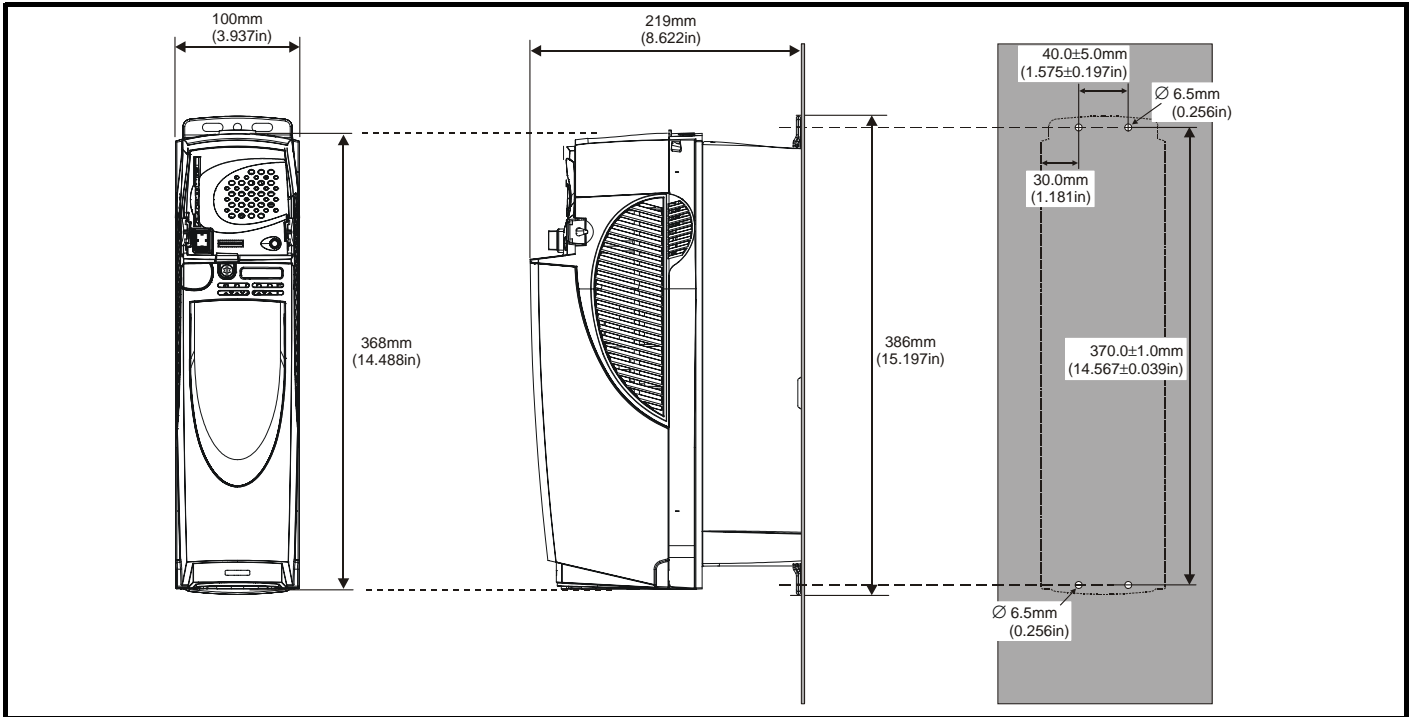
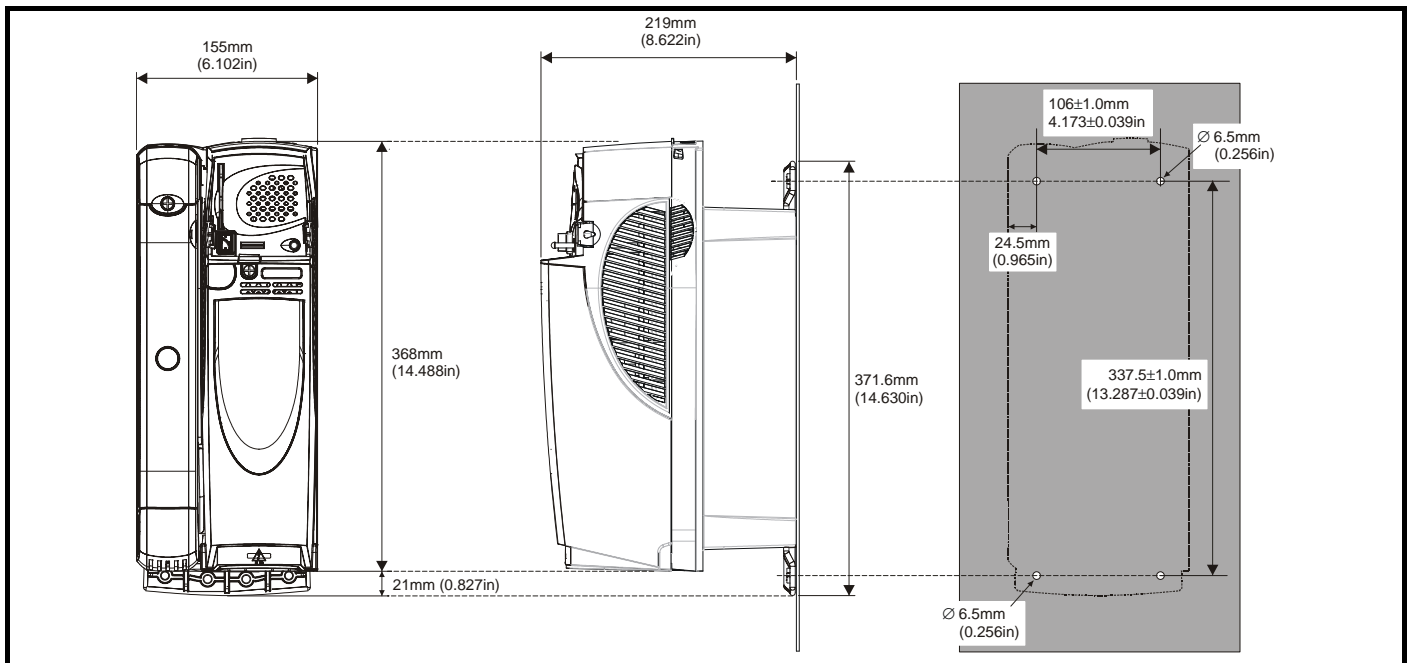
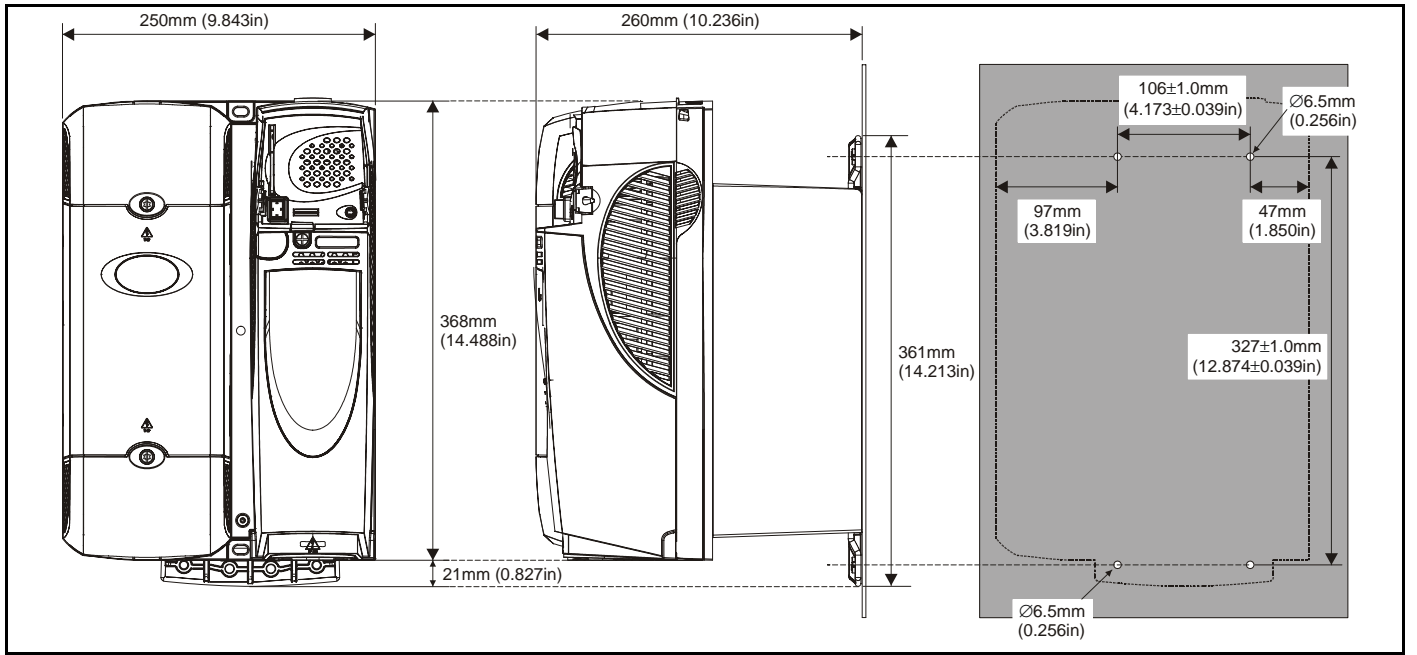


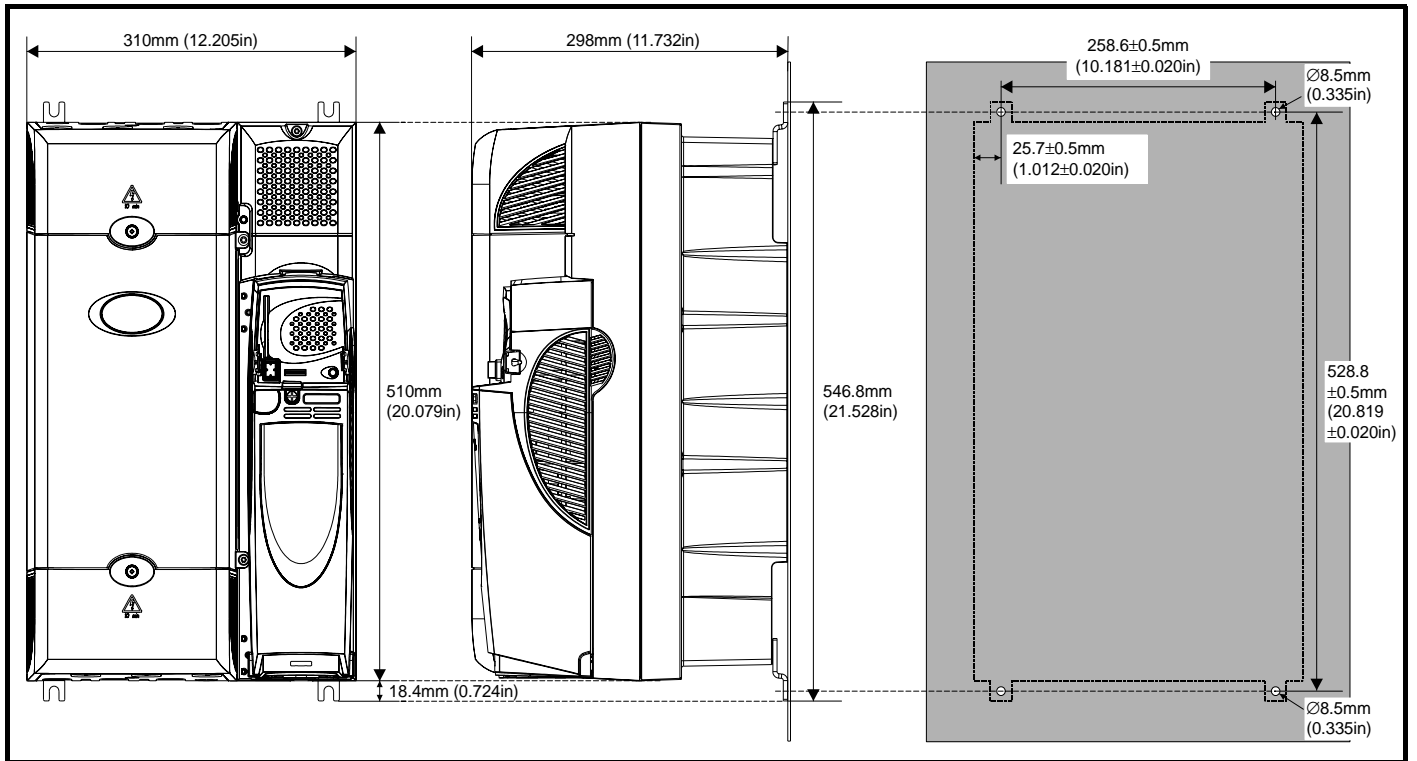
Figure 3-25 Surface mounting the size 2 drive



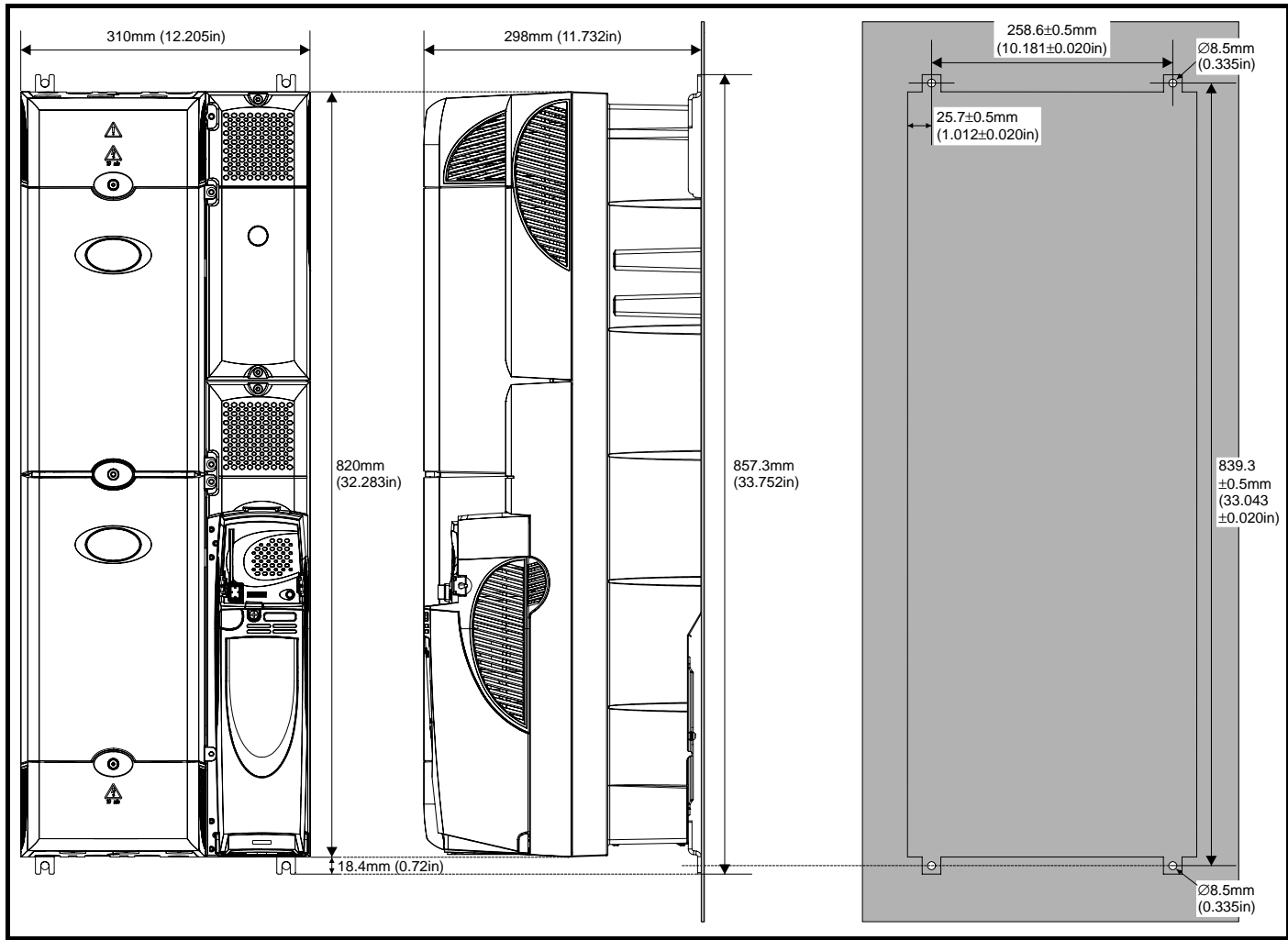
**Figure 3-26 Surface mounting the size 3 drive**



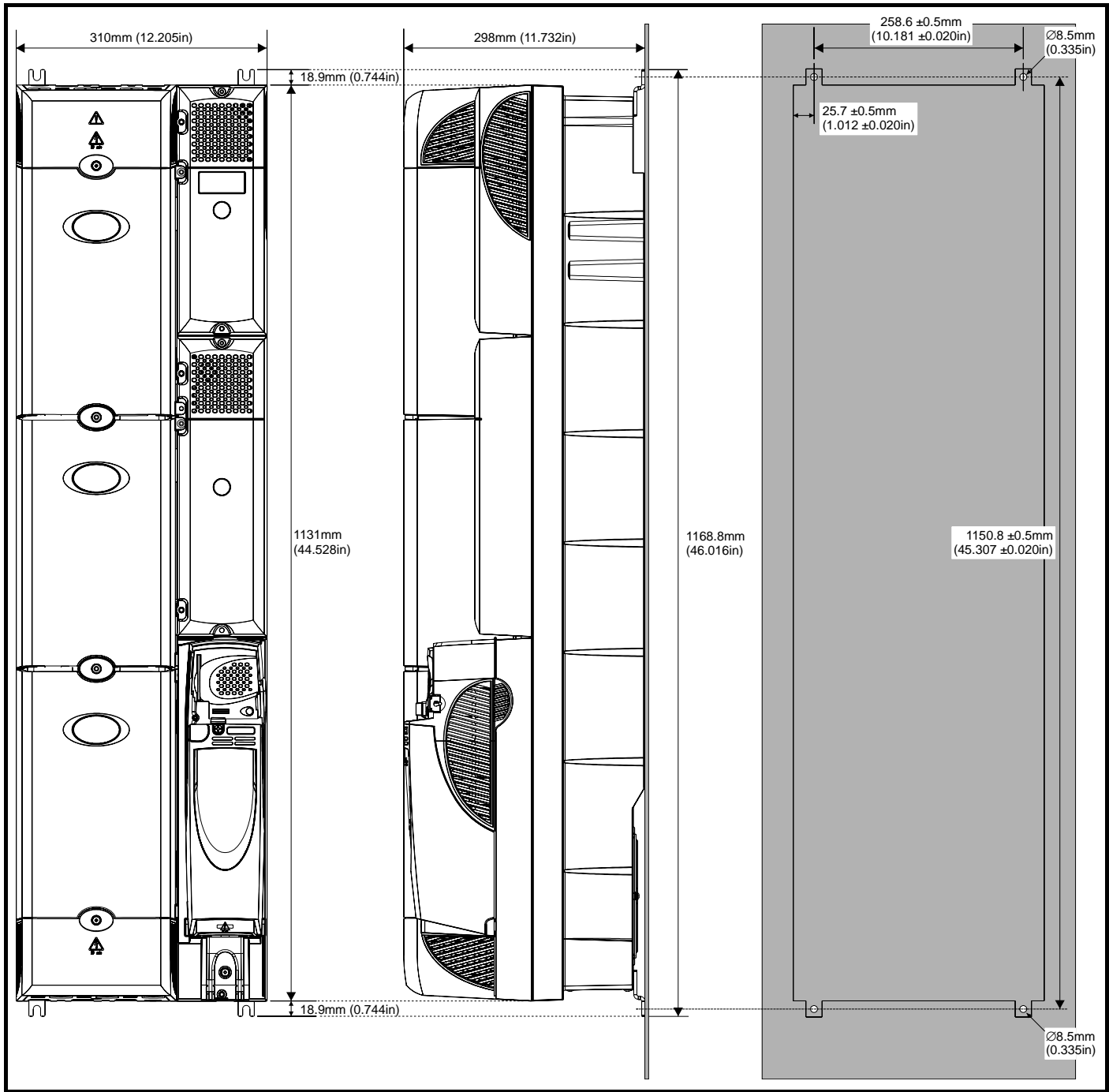
**Figure 3-27 Surface mounting the size 4 drive**



**Figure 3-28 Surface mounting the size 5 drive**



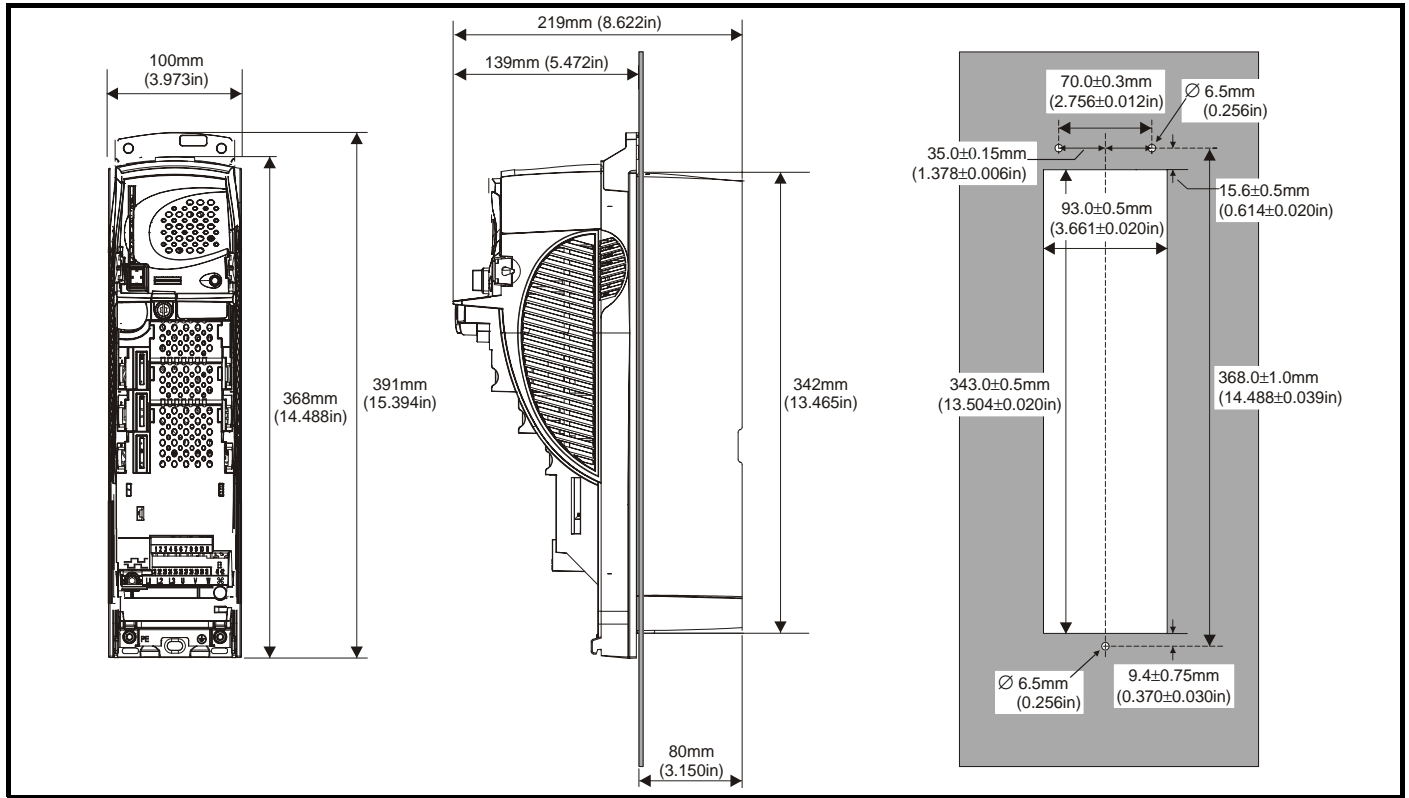
**Figure 3-29 Surface mounting the size 6 drive**



### 3.6.2 Through-panel mounting

When the drive is through-panel mounted, the main terminal cover(s) must be removed in order to provide access to the mounting holes. Once the drive has been mounted, the terminal cover(s) can be replaced.

**Figure 3-30 Through-panel mounting the size 1 drive**



**Figure 3-31 Through-panel mounting the size 2 drive**

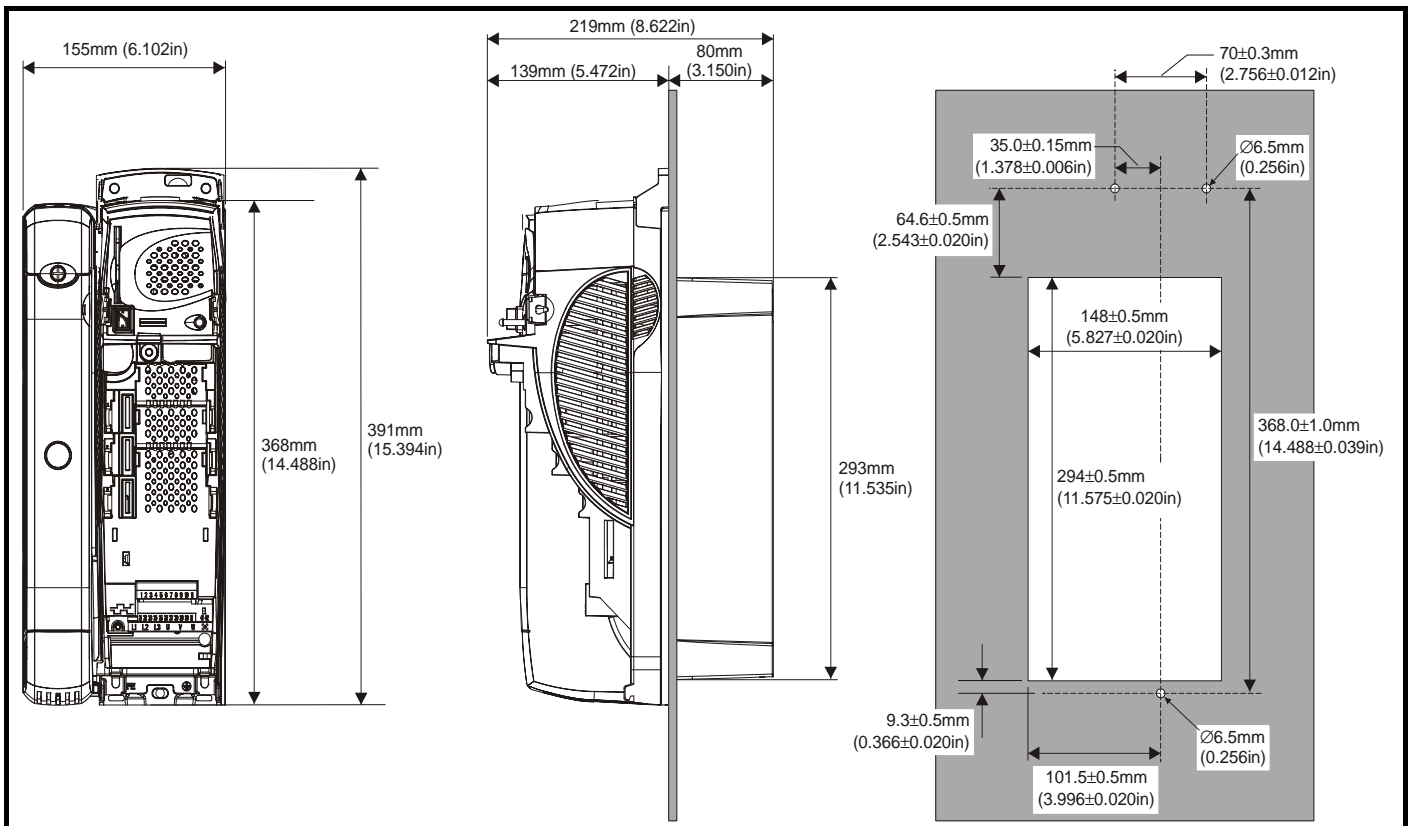


Figure 3-32 Through-panel mounting the size 3 drive

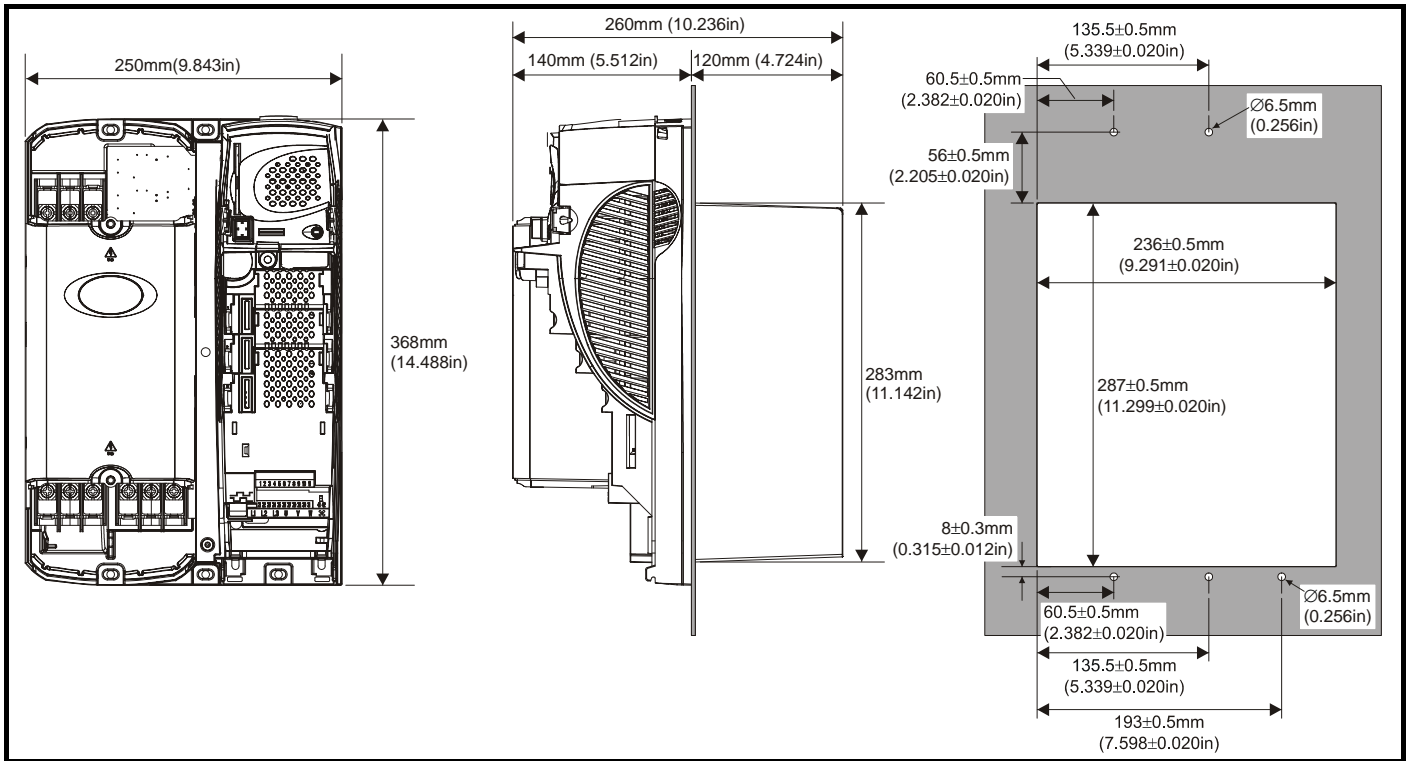
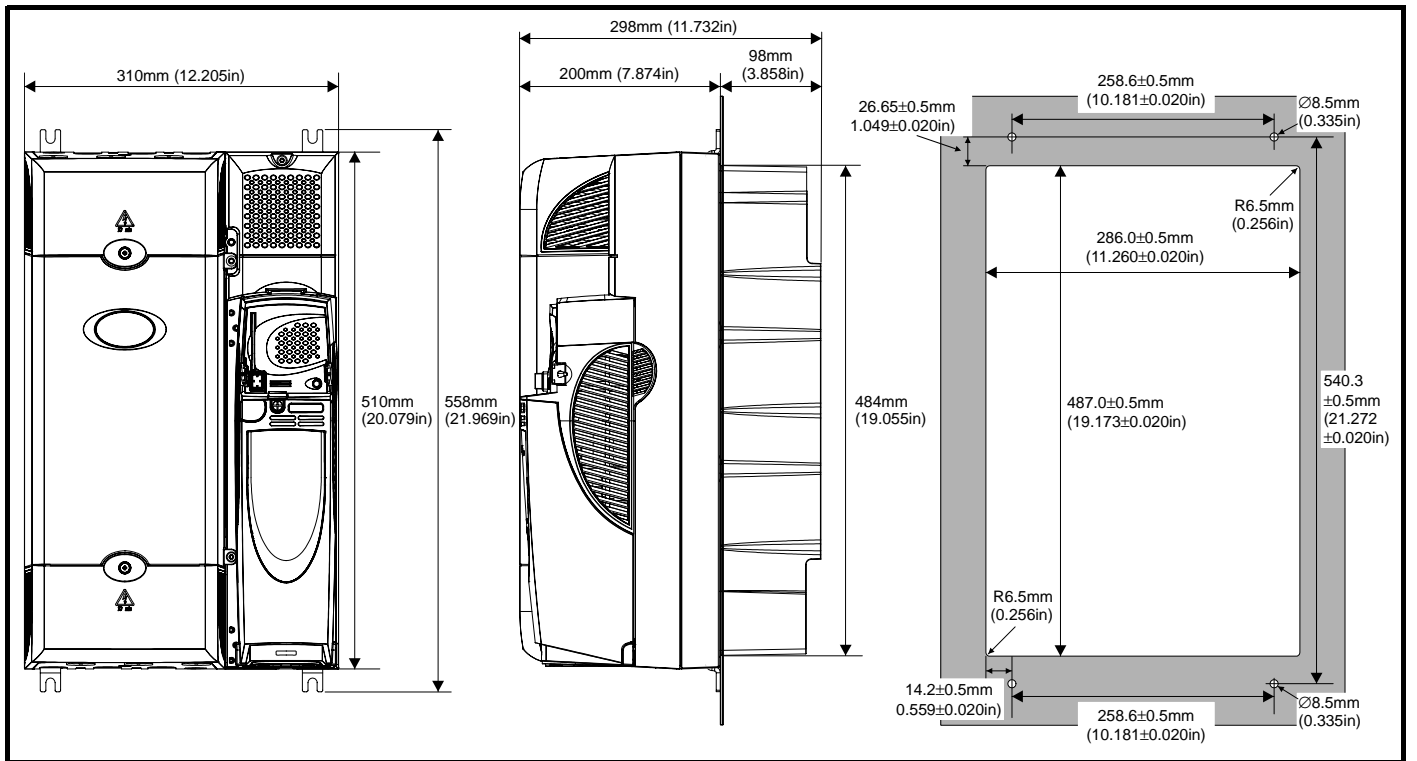
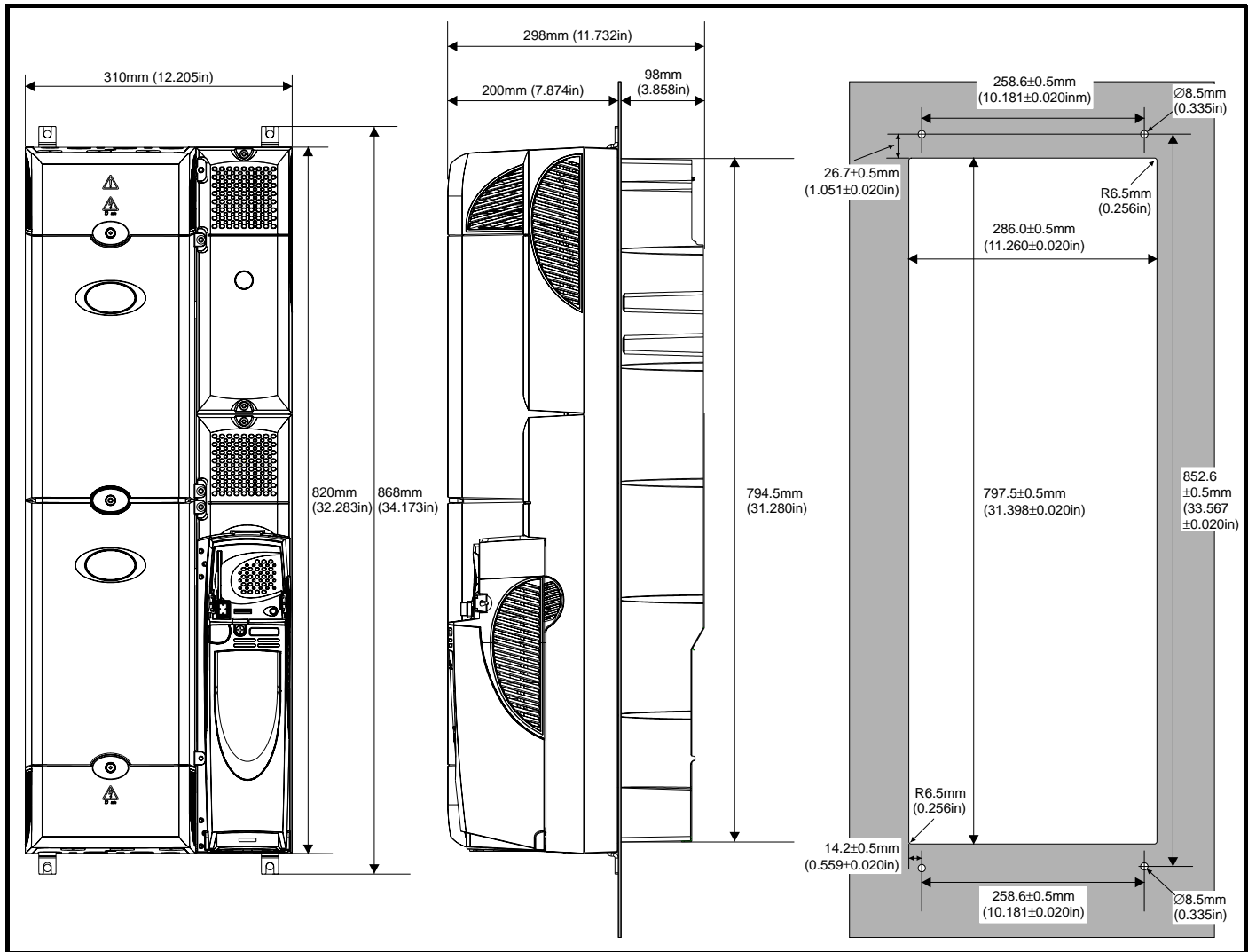


Figure 3-33 Through-panel mounting the size 4 drive



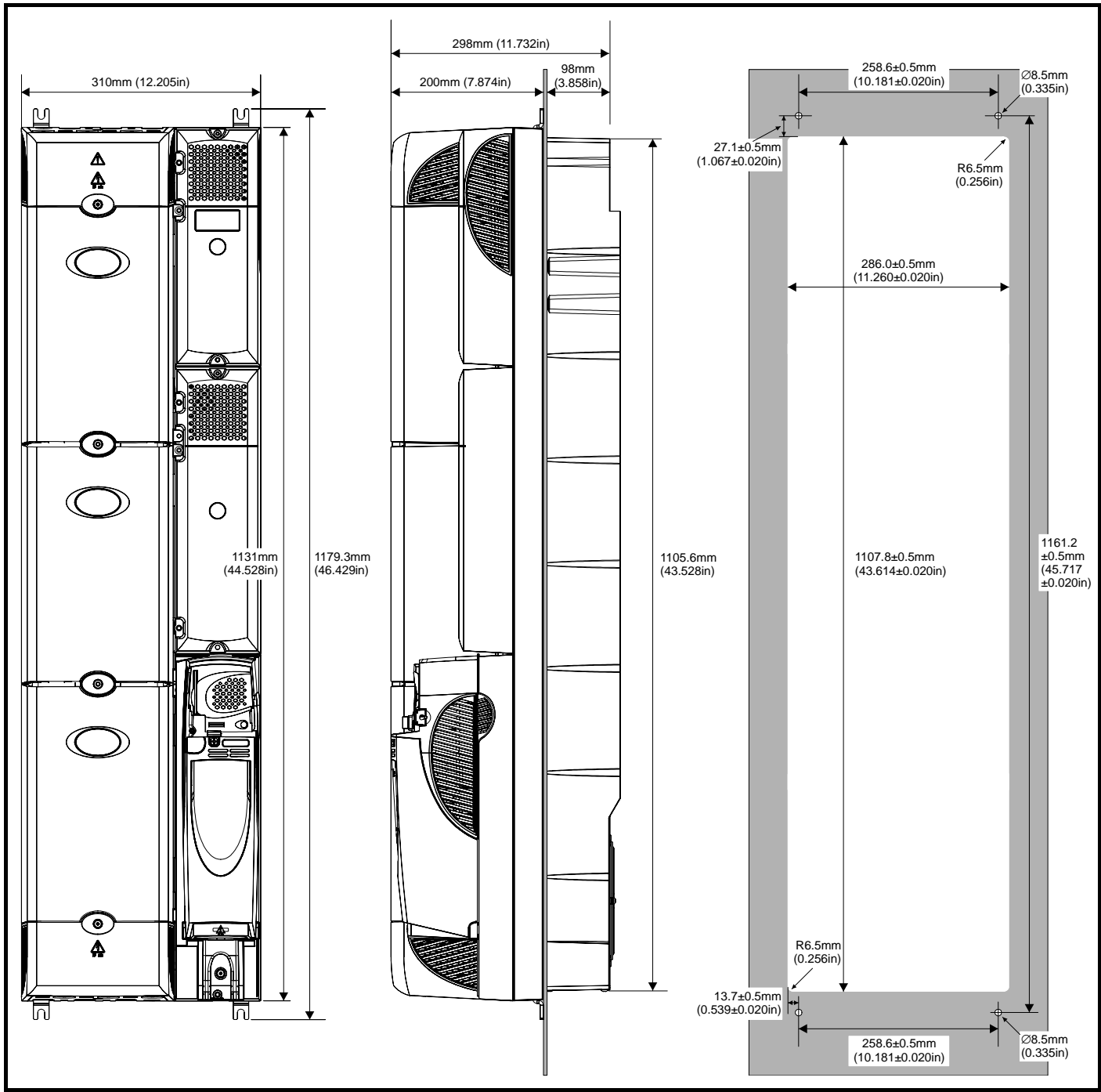
When a Unidrive SP size 4 or 5 is through-panel mounted, the grounding link bracket must be folded upwards. This is required to provide a grounding point for the grounding bracket. See section 4.11.1 *Grounding hardware* on page 83 for more information.

**Figure 3-34 Through-panel mounting the size 5 drive**



When a Unidrive SP size 4 or 5 is through-panel mounted, the grounding link bracket must be folded upwards. This is required to provide a grounding point for the grounding bracket. See section 4.11.1 *Grounding hardware* on page 83 for more information.



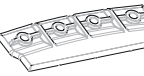

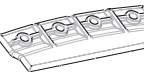



Figure 3-35 Through-panel mounting the size 6 drive



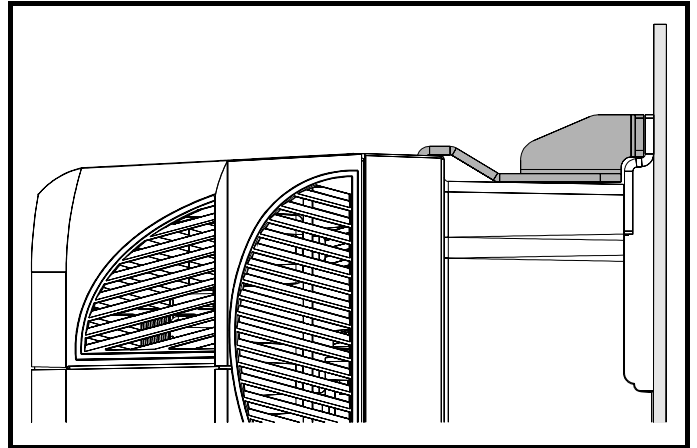
**NOTE**

In order to achieve IP54 rating (NEMA 12) for through-panel mounting, an IP54 insert must be fitted (size 1 and 2) and the heatsink fan should be replaced with an IP54 rated fan (sizes 1 to 4). Additionally, the gasket provided should be fitted between the drive and the backplate to ensure a good seal for the cubicle. If the heatsink mounted braking resistor is to be used with the drive through-panel mounted, refer to section 3.13 *Heatsink mounted braking resistor* on page 60 prior to mounting the drive. For further information refer to section 3.11 *IP Rating (Ingress Protection)* on page 53.

**Table 3-1 Mounting brackets**

| Model size | Surface  | Through-panel  | Hole size       |
|------------|--|--|-----------------|
| 1          |  x2 |  x1 | 6.5mm (0.256in) |
| 2          |  x2 |  x1 |                 |
| 3          |  x2 |  |                 |
| 4          |  |  x4 | 8.5mm (0.335in) |
| 5 & 6      |  |  x4 |                 |
|            |  x2 |  |                 |

**Figure 3-38 Location of top surface mounting brackets for size 5 and 6**

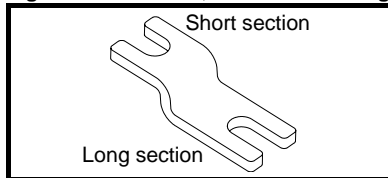


### 3.6.3 Fitting of the Unidrive SP mounting bracket on size 4, 5 and 6

Size 4, 5 and 6 of the Unidrive SP range use the same mounting brackets for surface and through-panel mounting.

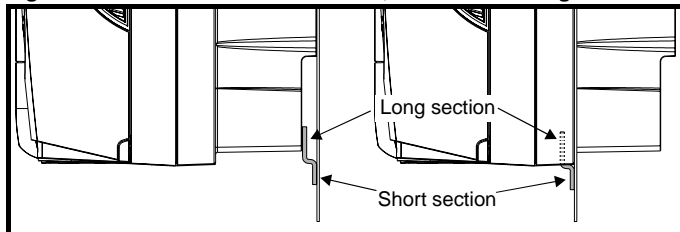
The mounting bracket has a long section and a short section.

**Figure 3-36 Size 4, 5 and 6 mounting bracket**



The mounting bracket must be fitted in the correct orientation with the long section inserted into or attached to the drive and the short section is attached to the back plate. Figure 3-37 shows the orientation of the mounting bracket when the drive is surface and through-panel mounted.

**Figure 3-37 Orientation of the size 4, 5 and 6 mounting bracket**

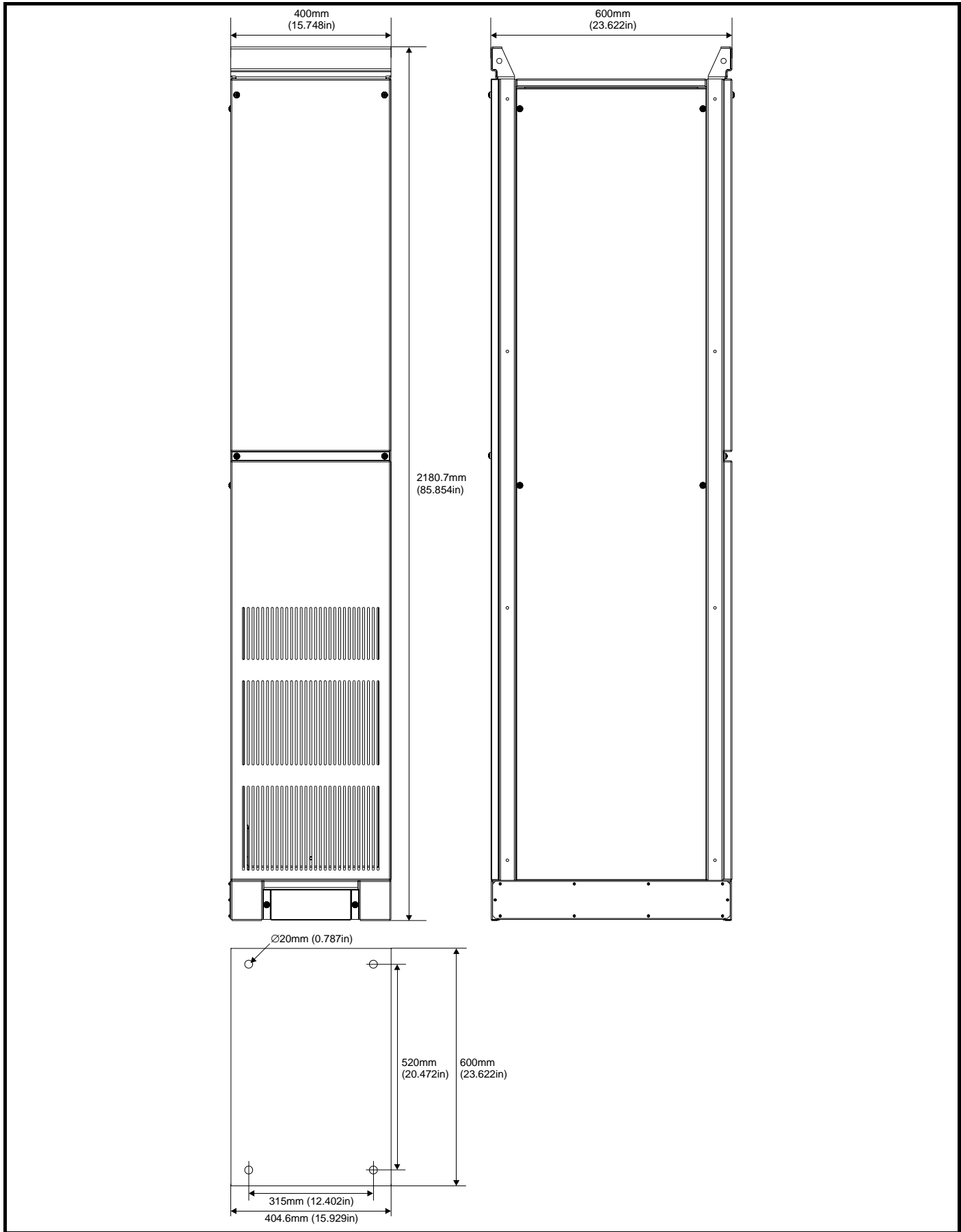


Unidrive SP size 6 also requires two top mounting brackets when the drive is surface mounted. The two brackets should be fitted to the top of the drive as shown in Figure 3-38.

The maximum torque setting for the screws into the drive chassis is 10 N m (7.4 lb. ft).

### 3.7 Free standing cubicle drive dimensions

Figure 3-39 Incomer shell / applications cubicle dimensions



**Figure 3-40 Size 8 free standing cubicle drive dimensions**

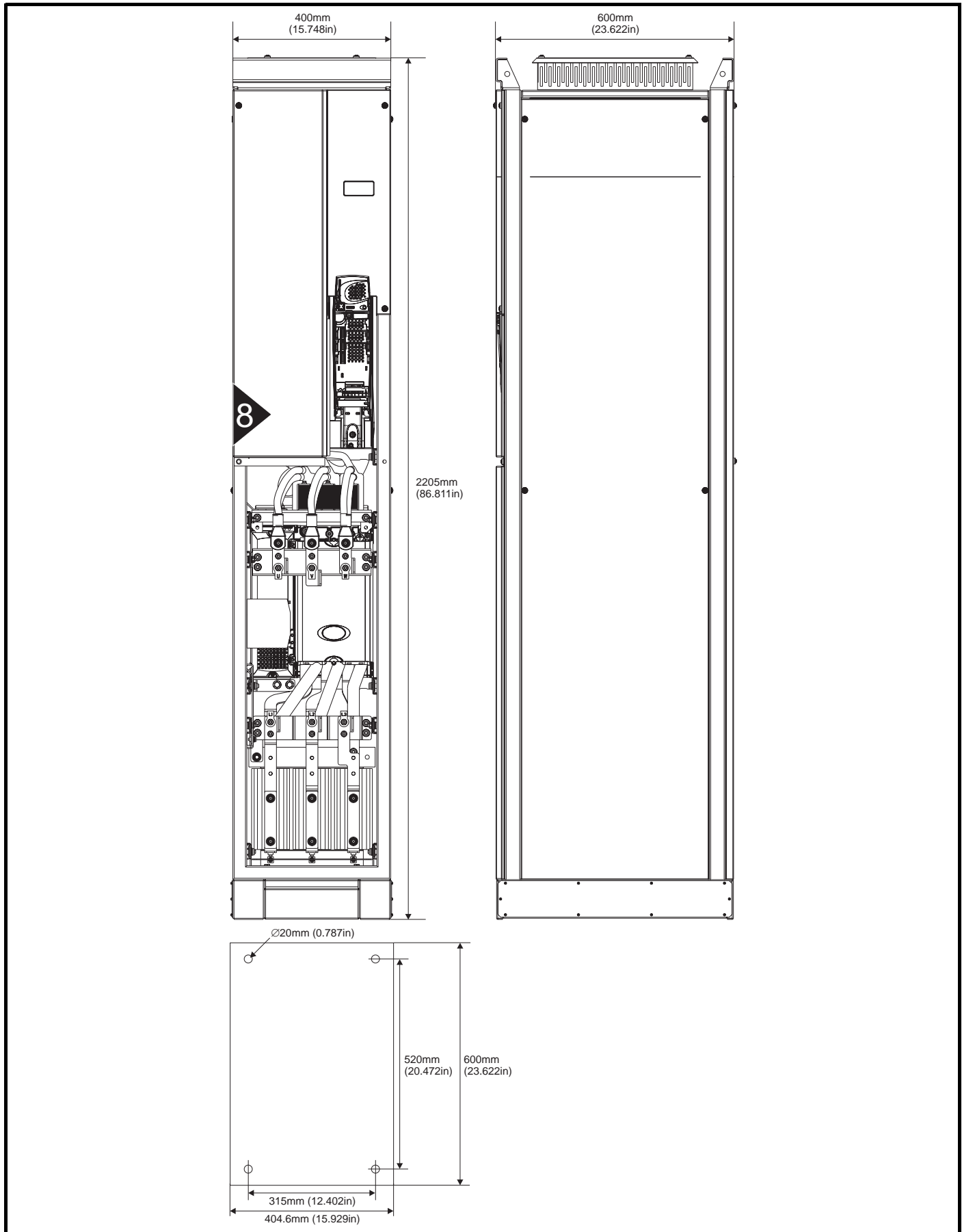
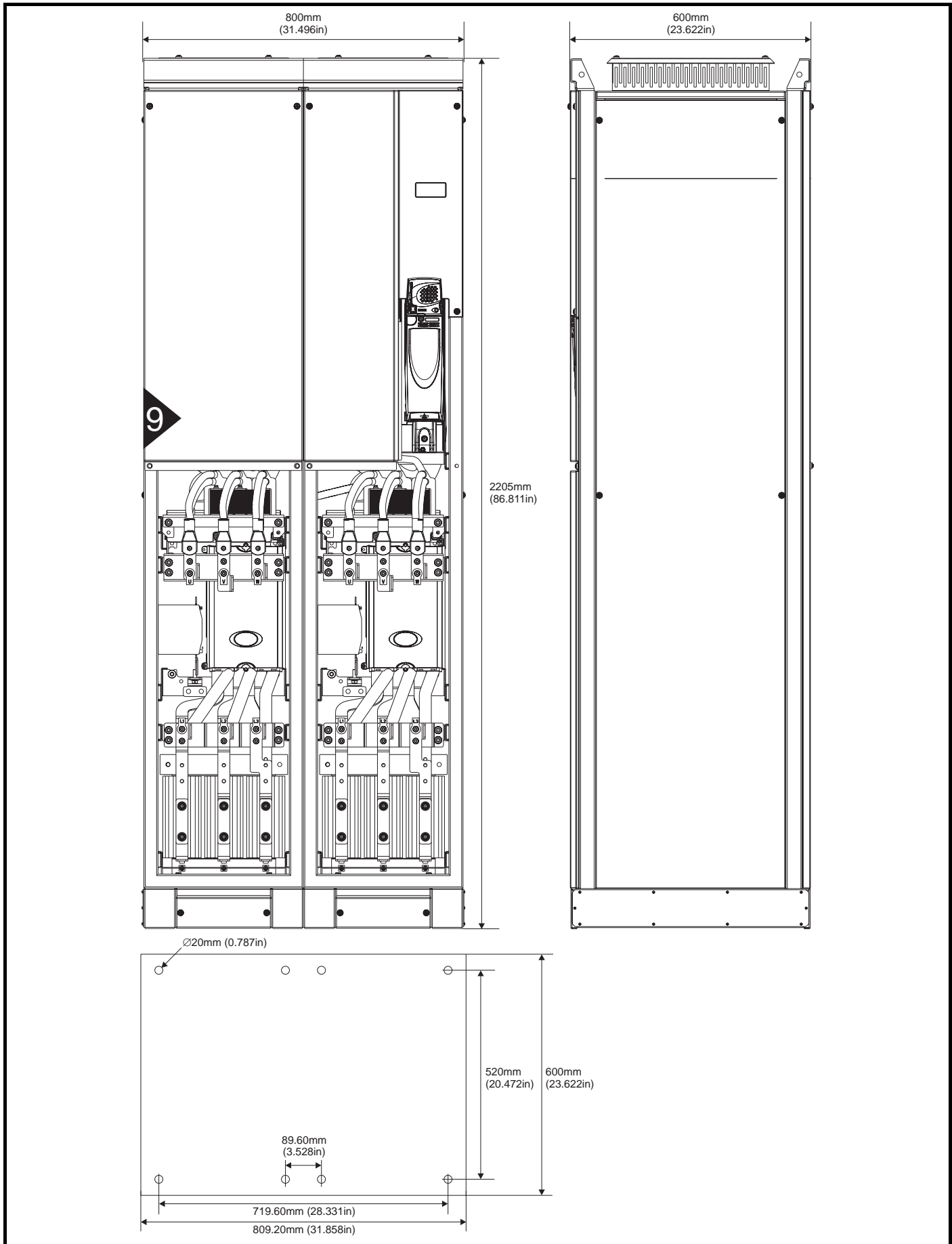


Figure 3-41 Size 9 free standing cubicle drive dimensions

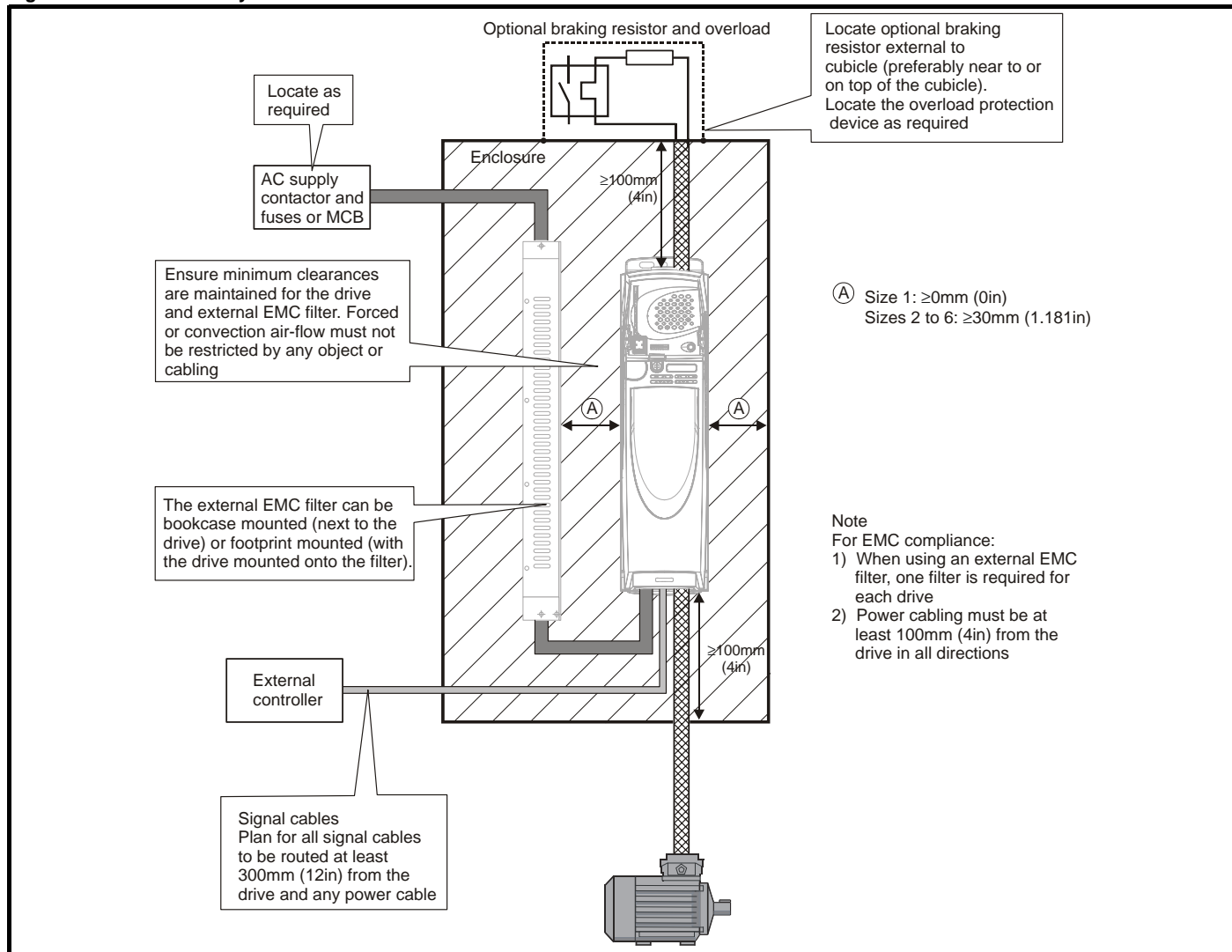


## 3.8 Enclosure

### 3.8.1 Enclosure layout

Please observe the clearances in the diagram below taking into account any appropriate notes for other devices / auxiliary equipment when planning the installation.

Figure 3-42 Enclosure layout



### 3.8.2 Enclosure sizing

1. Add the dissipation figures from section 12.1.2 *Power dissipation* on page 261 for each drive that is to be installed in the enclosure.
2. If an external EMC filter is to be used with each drive, add the dissipation figures from section 12.2.1 *EMC filter ratings* on page 273 for each external EMC filter that is to be installed in the enclosure.
3. If the braking resistor is to be mounted inside the enclosure, add the average power figures from for each braking resistor that is to be installed in the enclosure.
4. Calculate the total heat dissipation (in Watts) of any other equipment to be installed in the enclosure.
5. Add the heat dissipation figures obtained above. This gives a figure in Watts for the total heat that will be dissipated inside the enclosure.

#### Calculating the size of a sealed enclosure

The enclosure transfers internally generated heat into the surrounding air by natural convection (or external forced air flow); the greater the surface area of the enclosure walls, the better is the dissipation capability. Only the surfaces of the enclosure that are unobstructed (not in contact with a wall or floor) can dissipate heat.

Calculate the minimum required unobstructed surface area  $A_e$  for the enclosure from:

$$A_e = \frac{P}{k(T_{int} - T_{ext})}$$

Where:

- $A_e$  Unobstructed surface area in  $\text{m}^2$  ( $1 \text{ m}^2 = 10.9 \text{ ft}^2$ )
- $T_{ext}$  Maximum expected temperature in  $^{\circ}\text{C}$  *outside* the enclosure
- $T_{int}$  Maximum permissible temperature in  $^{\circ}\text{C}$  *inside* the enclosure
- $P$  Power in Watts dissipated by *all* heat sources in the enclosure
- $k$  Heat transmission coefficient of the enclosure material in  $\text{W}/\text{m}^2/^{\circ}\text{C}$

#### Example

To calculate the size of an enclosure for the following:

- Two SP 1406 models operating at the Normal Duty rating
- Each drive to operate at 6kHz PWM switching frequency
- Schaffner 16 A (4200-6119) external EMC filter for each drive
- Braking resistors are to be mounted outside the enclosure
- Maximum ambient temperature inside the enclosure:  $40^{\circ}\text{C}$
- Maximum ambient temperature outside the enclosure:  $30^{\circ}\text{C}$

Dissipation of each drive: 147 W (see section 12.1.2 *Power dissipation* on page 261)

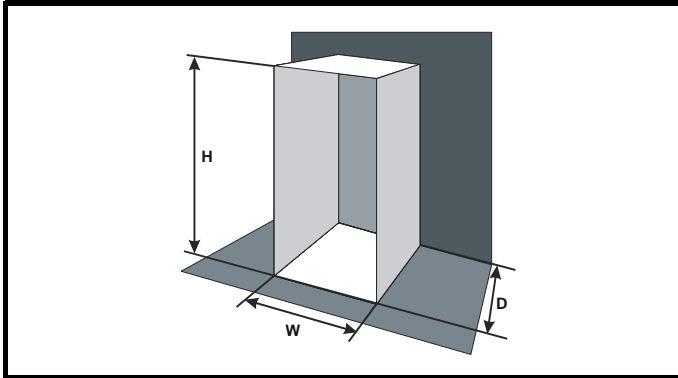
Dissipation of each external EMC filter: 9.2 W (max) (see section 12.2.1 *EMC filter ratings* on page 273)

Total dissipation:  $2 \times (147 + 9.2) = 312.4 \text{ W}$

The enclosure is to be made from painted 2 mm (0.079 in) sheet steel having a heat transmission coefficient of  $5.5 \text{ W/m}^2/^\circ\text{C}$ . Only the top, front, and two sides of the enclosure are free to dissipate heat.

The value of  $5.5 \text{ W/m}^2/^\circ\text{C}$  can generally be used with a sheet steel cubicle (exact values can be obtained by the supplier of the material). If in any doubt, allow for a greater margin in the temperature rise.

**Figure 3-43 Enclosure having front, sides and top panels free to dissipate heat**



Insert the following values:

|                  |                    |
|------------------|--------------------|
| $T_{\text{int}}$ | $40^\circ\text{C}$ |
| $T_{\text{ext}}$ | $30^\circ\text{C}$ |
| $k$              | 5.5                |
| $P$              | 312.4 W            |

The minimum required heat conducting area is then:

$$A_e = \frac{312.4}{5.5(40 - 30)}$$

$$= 5.68 \text{ m}^2 \text{ (61.9 ft}^2\text{)} \quad (1 \text{ m}^2 = 10.9 \text{ ft}^2)$$

Estimate two of the enclosure dimensions - the height (H) and depth (D), for instance. Calculate the width (W) from:

$$W = \frac{A_e - 2HD}{H + D}$$

Inserting  $H = 2\text{m}$  and  $D = 0.6\text{m}$ , obtain the minimum width:

$$W = \frac{5.68 - (2 \times 2 \times 0.6)}{2 + 0.6}$$

$$= 1.262 \text{ m (49.7 in)}$$

If the enclosure is too large for the space available, it can be made smaller only by attending to one or all of the following:

- Using a lower PWM switching frequency to reduce the dissipation in the drives
- Reducing the ambient temperature outside the enclosure, and/or applying forced-air cooling to the outside of the enclosure
- Reducing the number of drives in the enclosure
- Removing other heat-generating equipment

### Calculating the air-flow in a ventilated enclosure

The dimensions of the enclosure are required only for accommodating the equipment. The equipment is cooled by the forced air flow.

Calculate the minimum required volume of ventilating air from:

$$V = \frac{3kP}{T_{\text{int}} - T_{\text{ext}}}$$

Where:

|                  |  |
|------------------|--|
| $V$              | Air-flow in $\text{m}^3$ per hour ( $1 \text{ m}^3/\text{hr} = 0.59 \text{ ft}^3/\text{min}$ ) |
| $T_{\text{ext}}$ | Maximum expected temperature in $^\circ\text{C}$ <i>outside</i> the enclosure                  |
| $T_{\text{int}}$ | Maximum permissible temperature in $^\circ\text{C}$ <i>inside</i> the enclosure                |
| $P$              | Power in Watts dissipated by <i>all</i> heat sources in the enclosure                          |
| $k$              | Ratio of $\frac{P_o}{P_i}$   |

Where:

|       |   |
|-------|---|
| $P_o$ | is the air pressure at sea level        |
| $P_i$ | is the air pressure at the installation |

Typically use a factor of 1.2 to 1.3, to allow also for pressure-drops in dirty air-filters.

### Example

To calculate the size of an enclosure for the following:

- Three SP1403 models operating at the Normal Duty rating
- Each drive to operate at 6kHz PWM switching frequency
- Schaffner 10A (4200-6118) external EMC filter for each drive
- Braking resistors are to be mounted outside the enclosure
- Maximum ambient temperature inside the enclosure:  $40^\circ\text{C}$
- Maximum ambient temperature outside the enclosure:  $30^\circ\text{C}$

Dissipation of each drive: 61 W

Dissipation of each external EMC filter: 6.9 W (max)

Total dissipation:  $3 \times (61 + 6.9) = 203.7 \text{ W}$

Insert the following values:

|                  |                    |
|------------------|--------------------|
| $T_{\text{int}}$ | $40^\circ\text{C}$ |
| $T_{\text{ext}}$ | $30^\circ\text{C}$ |
| $k$              | 1.3                |
| $P$              | 203.7 W            |

Then:

$$V = \frac{3 \times 1.3 \times 203.7}{40 - 30}$$

$$= 79.4 \text{ m}^3/\text{hr (46.9 ft}^3/\text{min)} \quad (1 \text{ m}^3/\text{hr} = 0.59 \text{ ft}^3/\text{min})$$

## 3.9 Cubicle design and drive ambient temperature

Drive derating is required for operation in high ambient temperatures

Totally enclosing or through panel mounting the drive in either a sealed cabinet (no airflow) or in a well ventilated cabinet makes a significant difference on drive cooling.

The chosen method affects the ambient temperature value ( $T_{\text{rate}}$ ) which should be used for any necessary derating to ensure sufficient cooling for the whole of the drive.

The ambient temperature for the four different combinations is defined below:

1. Totally enclosed with no air flow ( $<2 \text{ m/s}$ ) over the drive  
 $T_{\text{rate}} = T_{\text{int}} + 5^\circ\text{C}$
2. Totally enclosed with air flow ( $>2 \text{ m/s}$ ) over the drive  
 $T_{\text{rate}} = T_{\text{int}}$
3. Through panel mounted with no airflow ( $<2 \text{ m/s}$ ) over the drive  
 $T_{\text{rate}} = \text{the greater of } T_{\text{ext}} + 5^\circ\text{C}, \text{ or } T_{\text{int}}$
4. Through panel mounted with air flow ( $>2 \text{ m/s}$ ) over the drive  
 $T_{\text{rate}} = \text{the greater of } T_{\text{ext}} \text{ or } T_{\text{int}}$

Where:

|                   |   |
|-------------------|---|
| $T_{\text{ext}}$  | = Temperature outside the cabinet   |
| $T_{\text{int}}$  | = Temperature inside the cabinet  |
| $T_{\text{rate}}$ | = Temperature used to select current rating from tables in Chapter 12 <i>Technical Data</i> . |

### 3.10 Heatsink fan operation

The Unidrive SP is ventilated by an internal heatsink mounted fan. The fan housing forms a baffle plate, channelling the air through the heatsink chamber. Thus, regardless of mounting method (surface mounting or through-panel mounting), the fitting of additional baffle plates is not required.

Ensure the minimum clearances around the drive are maintained to allow air to flow freely.

The heatsink fan on Unidrive SP size 1 and 2 is a dual speed fan and on size 3 to 6 it is a variable speed fan. The drive controls the speed at which the fan runs based on the temperature of the heatsink and the drive's thermal model system. The Unidrive SP size 3 to 6 is also fitted with single speed fan to ventilate the capacitor bank.

The heatsink fan on Unidrive SP size 1 to 5 is supplied internally by the drive. The heatsink fan on size 6 requires an external 24Vdc supply. See section 4.4 *Heatsink fan supply* on page 73 for more information.

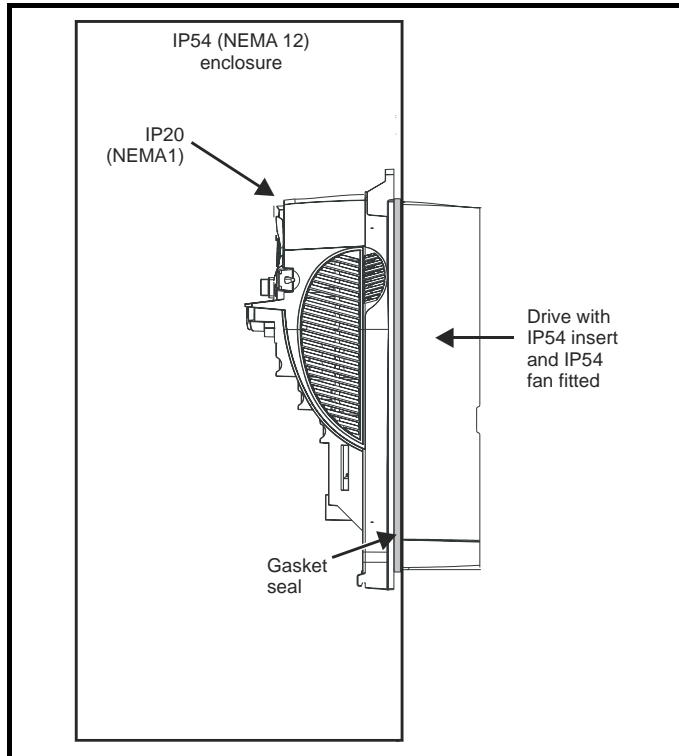
### 3.11 IP Rating (Ingress Protection)

An explanation of IP Rating is provided in section 12.1.9 *IP Rating (Ingress Protection)* on page 265.

The Unidrive SP is rated to IP20 pollution degree 2 (dry, non-conductive contamination only) (NEMA 1). However, it is possible to configure the drive to achieve IP54 rating (NEMA 12) at the rear of the heatsink for through-panel mounting (some current derating is required for size 1 and 2).

This allows the front of the drive, along with various switchgear, to be housed in an IP54 (NEMA 12) enclosure with the heatsink protruding through the panel to the external environment. Thus, the majority of the heat generated by the drive is dissipated outside the enclosure maintaining a reduced temperature inside the enclosure. This also relies on a good seal being made between the heatsink and the backplate using the gasket provided.

**Figure 3-44 Example of IP54 (NEMA 12) rating layout**



In order to achieve the high IP rating at the rear of the heatsink with Unidrive SP size 1 and 2, it is necessary to seal a heatsink vent by fitting the IP54 insert as shown in Figure 3-45 and Figure 3-46.

For increased fan lifetime in a dirty environment the heatsink fan must be replaced with an IP54 rated fan. Contact the supplier of the drive for

details. If the standard fan is used in a dirty/dusty environment, reduced fan lifetime will result. Regular cleaning of the fan and heatsink is recommended in this environment. The heatsink fan fitted to Unidrive SP sizes 5 and 6 are IP54 rated as standard.

The guidelines in Table 3-2 should be followed.

**Table 3-2 Environment considerations**

| Environment                 | IP54 Insert | Fan             | Comments   |
|-----------------------------|-------------|-----------------|--|
| Clean                       | Not fitted  | Standard        |  |
| Dry, dusty (non-conductive) | Fitted      | Standard        | Regular cleaning recommended. Fan lifetime may be reduced. |
| Dry, dusty (conductive)     | Fitted      | Standard / IP54 | Regular cleaning recommended. Fan lifetime may be reduced. |
| IP54 compliance             | Fitted      | IP54            | Regular cleaning recommended.                              |

**NOTE**

A current derating must be applied to the Unidrive SP size 1 and 2 if the IP54 insert and/or IP54 rated fan are fitted. Derating information is provided in section 12.1.1 *Power and current ratings (Derating for switching frequency and temperature)* on page 257.

Failure to do so may result in nuisance tripping.

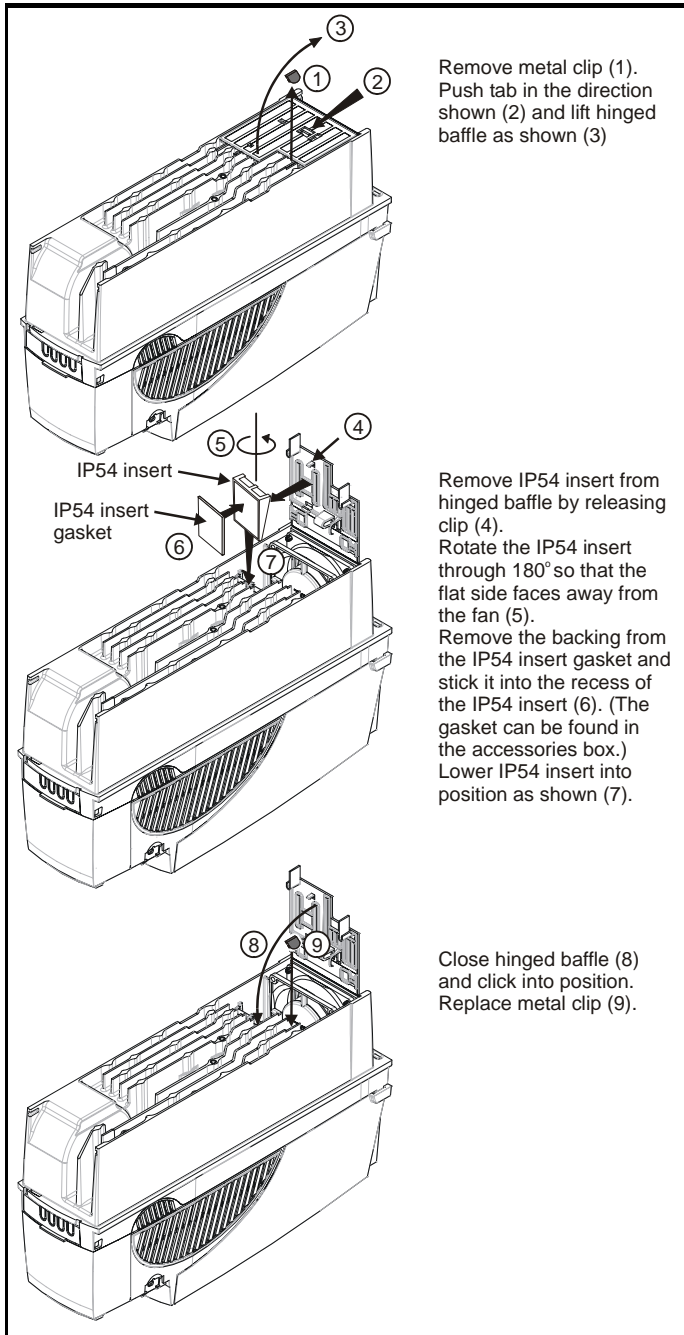
**NOTE**

When designing an IP54 (NEMA 12) cubicle (Figure 3-44), consideration should be made to the dissipation from the front of the drive.

**Table 3-3 Power losses from the front of the drive when through-panel mounted**

| Frame size | Power loss |
|------------|------------|
| 1          | ≤50W       |
| 2          | ≤75W       |
| 3          | ≤100W      |
| 4          | ≤204W      |
| 5          | ≤347W      |
| 6          | ≤480W      |

**Figure 3-45 Fitting of IP54 insert for size 1**



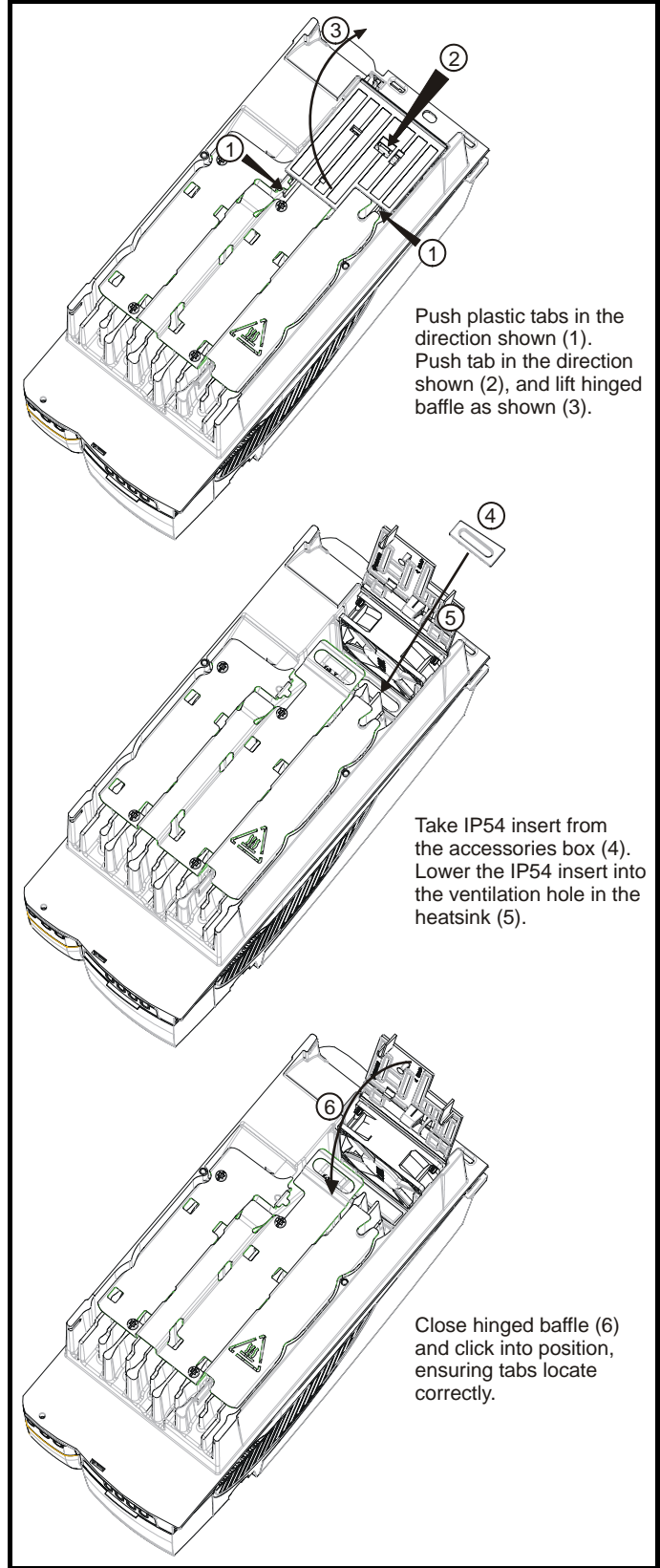
Remove metal clip (1). Push tab in the direction shown (2) and lift hinged baffle as shown (3)

Remove IP54 insert from hinged baffle by releasing clip (4). Rotate the IP54 insert through 180° so that the flat side faces away from the fan (5). Remove the backing from the IP54 insert gasket and stick it into the recess of the IP54 insert (6). (The gasket can be found in the accessories box.) Lower IP54 insert into position as shown (7).

Close hinged baffle (8) and click into position. Replace metal clip (9).

In order to remove the IP54 insert, repeat steps (1), (2) and (3), reverse steps (7), (6), (5) and (4) and repeat steps (8) and (9).

**Figure 3-46 Fitting of IP54 insert for size 2**



Push plastic tabs in the direction shown (1). Push tab in the direction shown (2), and lift hinged baffle as shown (3).

Take IP54 insert from the accessories box (4). Lower the IP54 insert into the ventilation hole in the heatsink (5).

Close hinged baffle (6) and click into position, ensuring tabs locate correctly.

In order to remove the IP54 insert, repeat steps (1) (2) and (3), reverse steps (5) and (4) and repeat step (6).

### 3.12 External EMC filter

In order to provide our customers with a degree of flexibility, external EMC filters have been sourced from two manufacturers: Schaffner & Epcos. Filter details for each drive rating are provided in the tables below. Both the Schaffner and Epcos filters meet the same specifications.

**Table 3-4 Drive EMC filter details (size 1 to 6)**

| Drive            | Schaffner   |                   | Epcos       |                   |
|------------------|-------------|-------------------|-------------|-------------------|
|                  | CT part no. | Weight            | CT part no. | Weight            |
| SP1201 to SP1204 | 4200-6118   | 1.4 kg (3.1 lb)   | 4200-6121   | 2.1 kg (4.6 lb)   |
|                  | 4200-6119   |                   | 4200-6120   |                   |
| SP1401 to SP1404 | 4200-6118   | 1.4 kg (3.1 lb)   | 4200-6121   | 2.1 kg (4.6 lb)   |
| SP1405 to SP1406 | 4200-6119   |                   | 4200-6120   |                   |
| SP2201 to SP2203 | 4200-6210   | 2.0 kg (4.4 lb)   | 4200-6211   | 3.3 kg (7.3 lb)   |
| SP2401 to SP2404 | 4200-6210   | 2.0 kg (4.4 lb)   | 4200-6211   | 3.3 kg (7.3 lb)   |
| SP3201 to SP3202 | 4200-6307   | 3.5 kg (7.7 lb)   | 4200-6306   | 5.1 kg (11.2 lb)  |
| SP4201 to SP4203 | 4200-6406   | 4.0 kg (8.8 lb)   | 4200-6405   | 7.8 kg (17.2 lb)  |
| SP3401 to SP3403 | 4200-6305   | 3.5 kg (7.7 lb)   | 4200-6306   | 5.1 kg (11.2 lb)  |
| SP3501 to SP3507 | 4200-6309   |                   | 4200-6308   |                   |
| SP4401 to SP4403 | 4200-6406   | 4.0 kg (8.8 lb)   | 4200-6405   | 7.8 kg (17.2 lb)  |
| SP4601 to SP4606 | 4200-6408   | 3.8 kg (8.4 lb)   | 4200-6407   | 8.0 kg (17.6 lb)  |
| SP5401 to SP5402 | 4200-6503   | 6.8 kg (15.0 lb)  | 4200-6501   | 12.0 kg (26.5 lb) |
| SP5601 to SP5602 | 4200-6504   | 4.4 kg (9.7 lb)   | 4200-6502   | 10.0 kg (22.0 lb) |
| SP6401 to SP6402 | 4200-6603   | 5.25 kg (11.6 lb) | 4200-6601   |                   |
| SP6601 to SP6602 | 4200-6604   |                   | 4200-6602   |                   |

For free standing cubicle drives (size 8 and 9), EMC filters can be sourced directly from Schaffner and Epcos. See Table 3-5 for details.

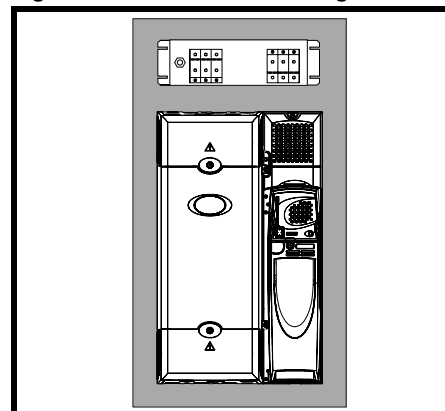
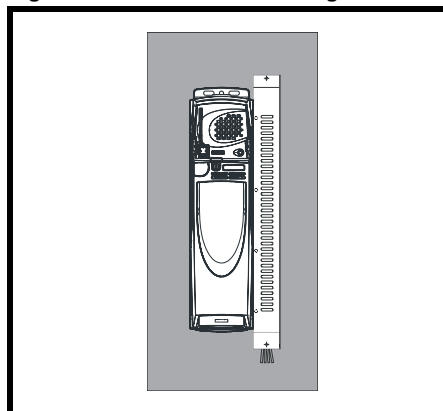
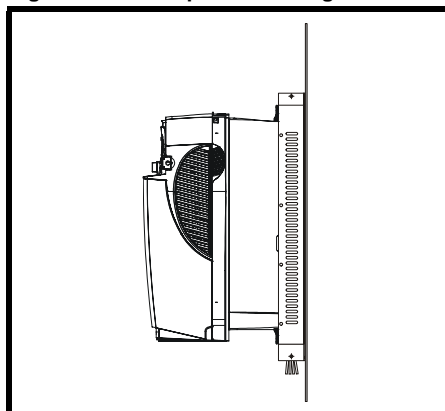
**Table 3-5 Free standing cubicle drive EMC filter details (size 8 and 9)**

| Drive  | Power (kW) | Input (A) | Filter rating (A) | Filter (V) | Epcos part number | Schaffner part number |
|--------|------------|-----------|-------------------|------------|-------------------|-----------------------|
| SP8411 | 185/200    | 408       | 600               | 415        | B84143-B600-S20   | FN3359-600-99         |
| SP8412 | 225/250    | 467       | 600               | 415        | B84143-B600-S20   | FN3359-600-99         |
| SP8413 | 250/315    | 576       | 600               | 415        | B84143-B600-S20   | FN3359-600-99         |
| SP8414 | 315/355    | 678       | 1000              | 415        | B84143-B1000-S20  | FN3359-1000-99        |
| SP9411 | 355/400    | 864       | 1000              | 415        | B84143-B1000-S20  | FN3359-1000-99        |
| SP9412 | 400/450    | 864       | 1000              | 415        | B84143-B1000-S20  | FN3359-1000-99        |
| SP9413 | 450/500    | 935       | 1000              | 415        | B84143-B1000-S20  | FN3359-1000-99        |
| SP9414 | 500/560    | 1151      | 1600              | 415        | B84143-B1600-S20  | FN3359-1600-99        |
| SP9415 | 560/675    | 1356      | 1600              | 415        | B84143-B1600-S20  | FN3359-1600-99        |

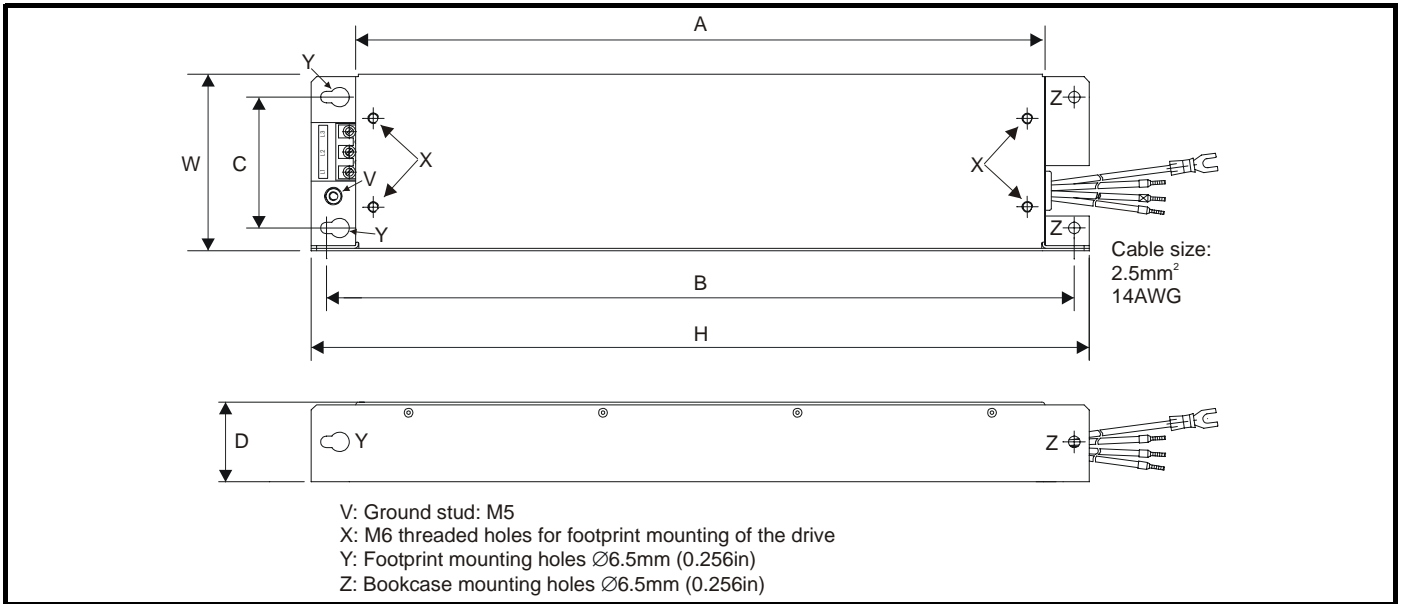
The external EMC filters for sizes 1 to 3 can be footprint or bookcase mounted, see Figure 3-47 and Figure 3-48. The external EMC filters for sizes 4 to 6 are designed to be mounted above the drive, as shown in Figure 3-49.

Mount the external EMC filter following the guidelines in section 4.11.5 *Compliance with generic emission standards* on page 88.

**Figure 3-47 Footprint mounting the EMC filter** **Figure 3-48 Bookcase mounting the EMC filter** **Figure 3-49 Size 4 to 6 mounting of EMC filter**



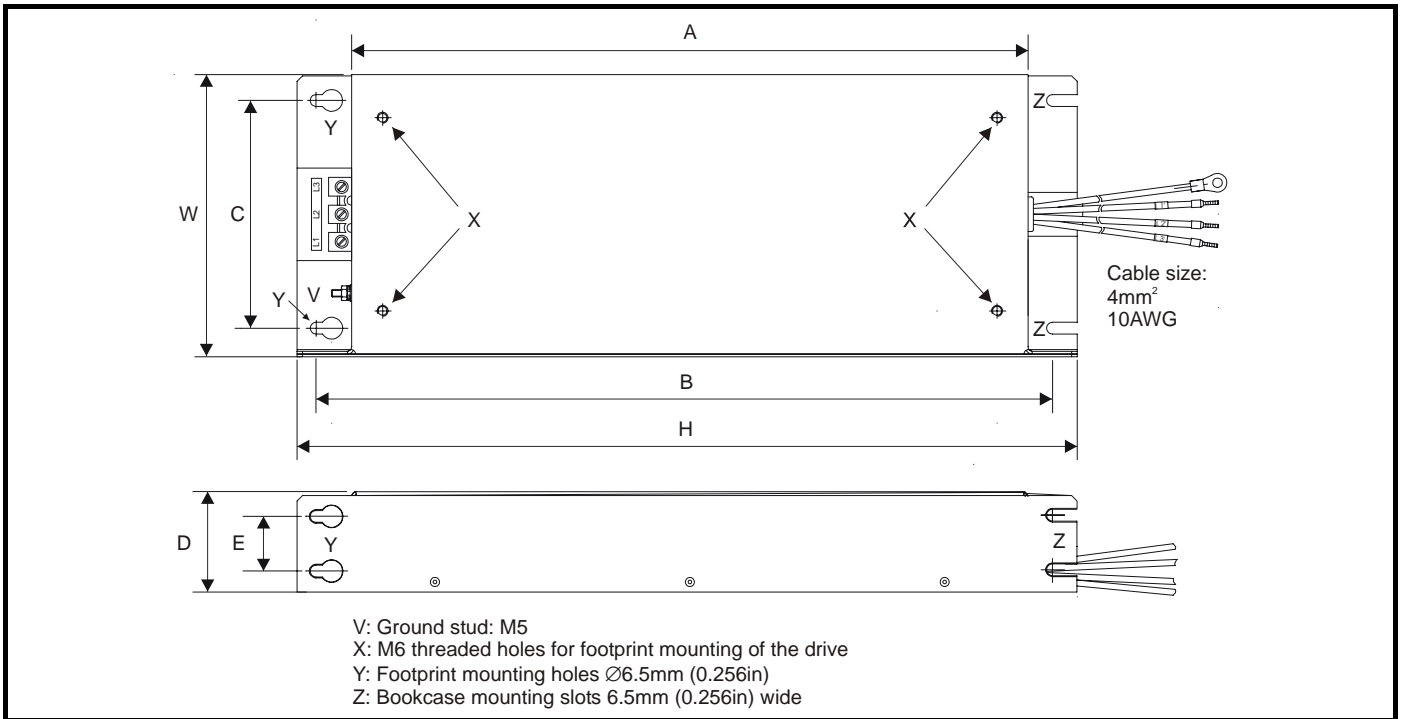
**Figure 3-50 Size 1 external EMC filter**



All filter mounting holes are suitable for M6 fasteners.

| CT part no. | Manufacturer | A                     | B                     | C                   | D                   | H                     | W                    |
|-------------|--------------|-----------------------|-----------------------|---------------------|---------------------|-----------------------|----------------------|
| 4200-6118   | Schaffner    | 390 mm<br>(15.354 in) | 423 mm<br>(16.654 in) | 74 mm<br>(2.913 in) | 45 mm<br>(1.772 in) | 440 mm<br>(17.323 in) | 100 mm<br>(3.937 in) |
| 4200-6119   |              |                       |                       |                     |                     | 450 mm<br>(17.717 in) |                      |
| 4200-6121   | Epcos        | 390 mm<br>(15.354 in) | 423 mm<br>(16.654 in) | 74 mm<br>(2.913 in) | 45 mm<br>(1.772 in) | 440 mm<br>(17.323 in) | 100 mm<br>(3.937 in) |
| 4200-6120   |              |                       |                       |                     |                     | 450 mm<br>(17.717 in) |                      |

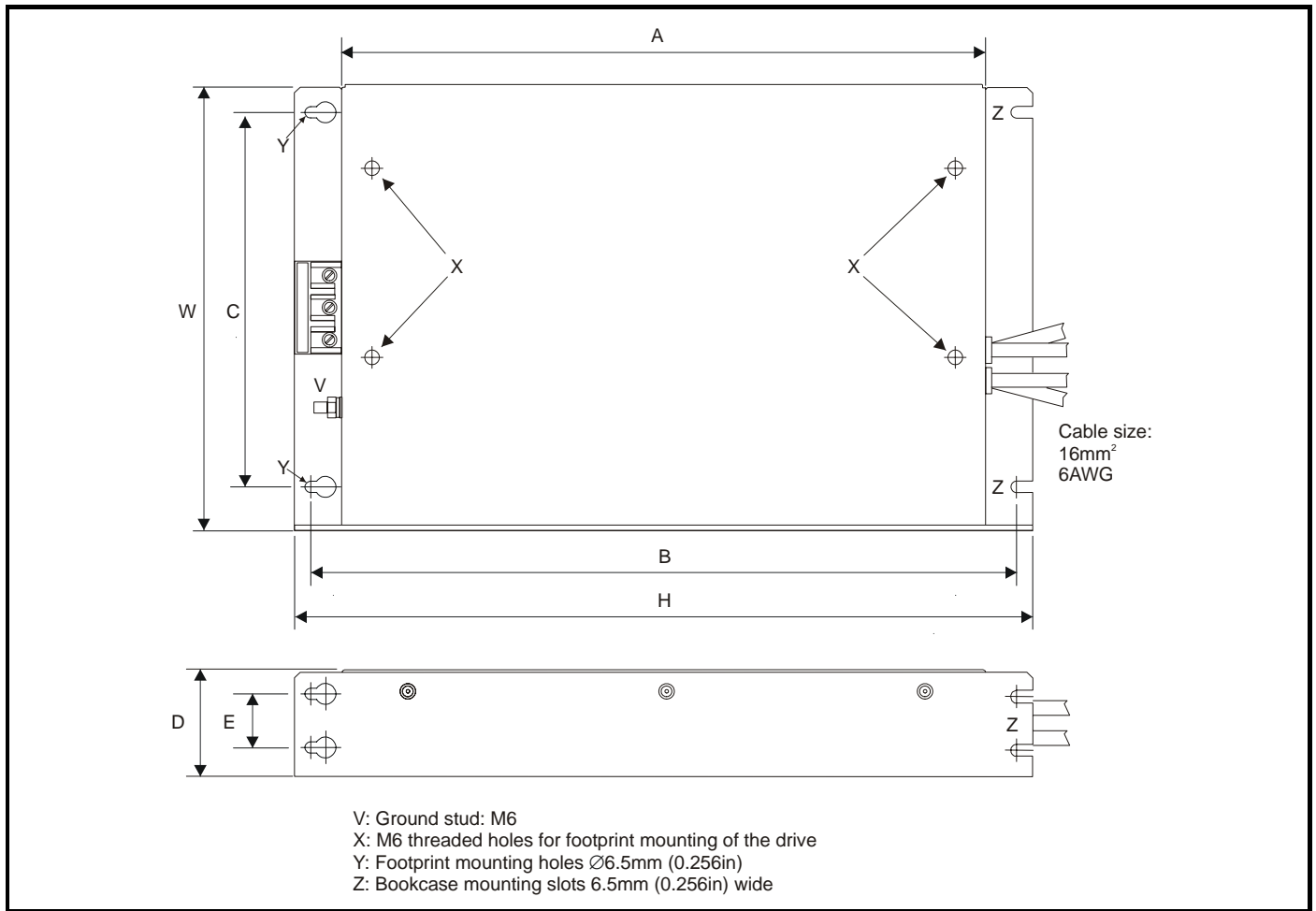
**Figure 3-51 Size 2 external EMC filter**



All filter mounting holes are suitable for M6 fasteners.

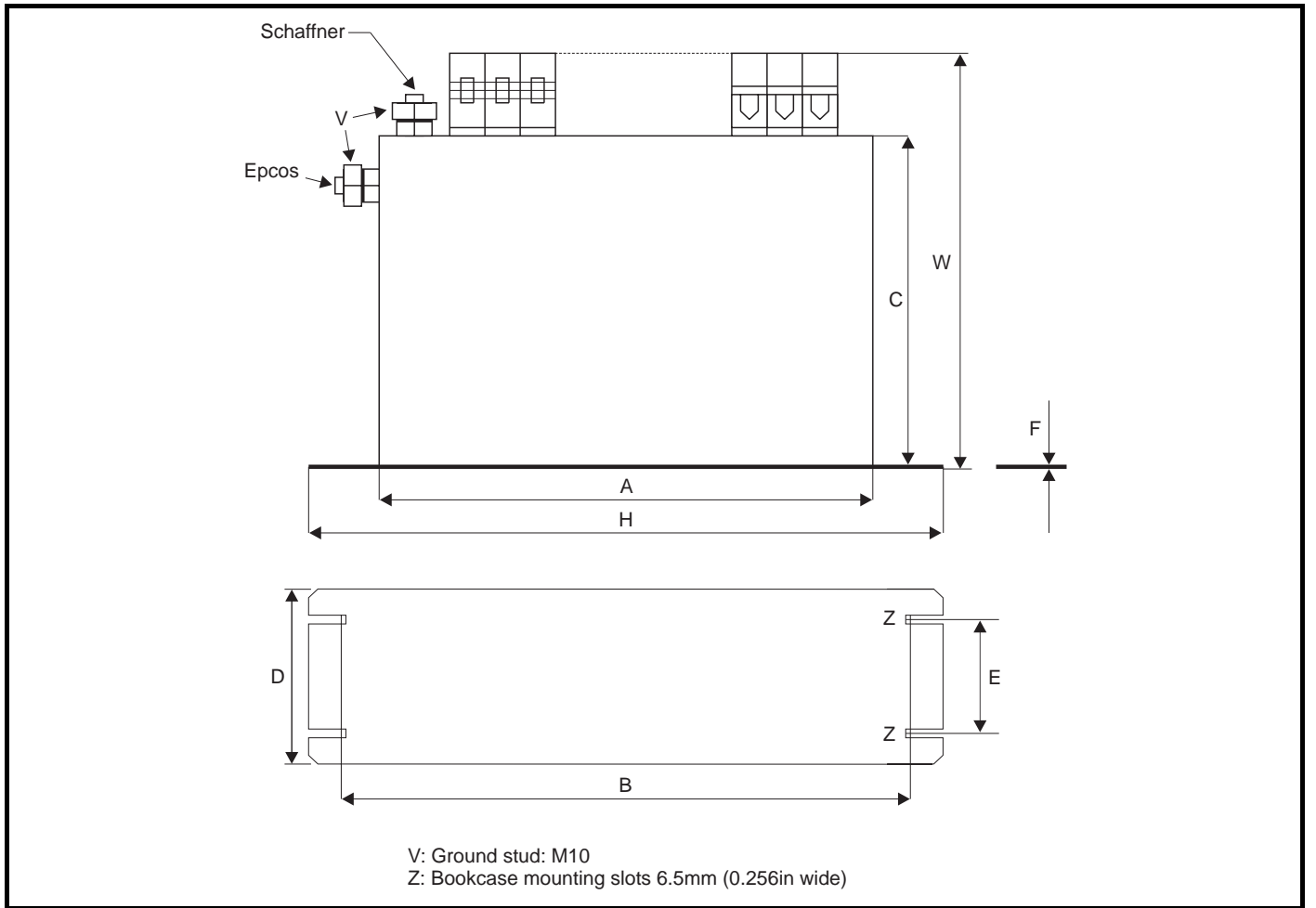
| CT part no. | Manufacturer | A                       | B                       | C                    | D                   | E                   | H                       | W                    |
|-------------|--------------|-------------------------|-------------------------|----------------------|---------------------|---------------------|-------------------------|----------------------|
| 4200-6210   | Schaffner    | 371.5 mm<br>(14.626 in) | 404.5 mm<br>(15.925 in) | 125 mm<br>(4.921 in) | 55 mm<br>(2.165 in) | 30 mm<br>(1.181 in) | 428.5 mm<br>(16.870 in) | 155 mm<br>(6.102 in) |
| 4200-6211   | Epcos        | 371.5 mm<br>(14.626 in) | 404.5 mm<br>(15.925 in) | 125 mm<br>(4.921 in) | 55 mm<br>(2.165 in) | 30 mm<br>(1.181 in) | 431.5 mm<br>(16.988 in) |                      |

Figure 3-52 Size 3 external EMC filter



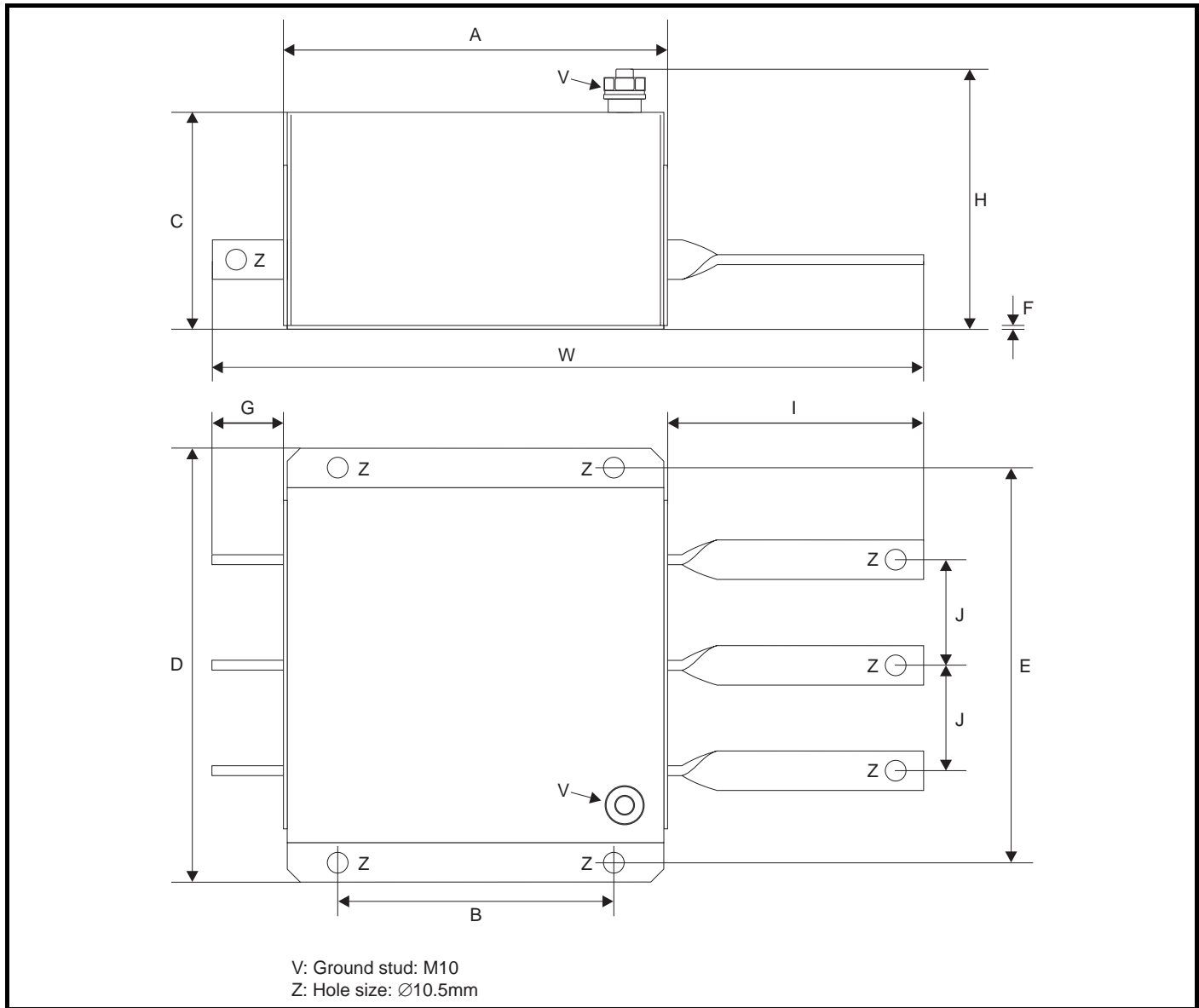
| CT part no. | Manufacturer | A                     | B                     | C                    | D                   | E                   | H                     | W                    |
|-------------|--------------|-----------------------|-----------------------|----------------------|---------------------|---------------------|-----------------------|----------------------|
| 4200-6305   | Schaffner    | 361 mm<br>(14.213 in) | 396 mm<br>(15.591 in) | 210 mm<br>(8.268 in) | 60 mm<br>(2.362 in) | 30 mm<br>(1.181 in) | 414 mm<br>(16.299 in) | 250 mm<br>(9.843 in) |
| 4200-6307   |              |                       |                       |                      |                     |                     |                       |                      |
| 4200-6309   |              |                       |                       |                      |                     |                     |                       |                      |
| 4200-6306   | Epcos        | 365 mm<br>(14.370 in) |                       |                      |                     |                     | 425 mm<br>(16.732 in) |                      |
| 4200-6308   |              |                       |                       |                      |                     |                     |                       |                      |

**Figure 3-53 Size 4 and 5 external EMC filter**



| CT part no. | Manufacturer | A                     | B                     | C                    | D                    | E                   | F                   | H                     | W                    |                      |                      |
|-------------|--------------|-----------------------|-----------------------|----------------------|----------------------|---------------------|---------------------|-----------------------|----------------------|----------------------|----------------------|
| 4200-6406   | Schaffner    | 260 mm<br>(10.236 in) | 275 mm<br>(10.827 in) | 170 mm<br>(6.693 in) | 100 mm<br>(3.937 in) | 65 mm<br>(2.559 in) | 1.5 mm<br>(0.059in) | 300 mm<br>(11.811 in) | 225 mm<br>(8.858 in) |                      |                      |
| 4200-6408   |              |                       |                       |                      | 120 mm<br>(4.724 in) | 85 mm<br>(3.346 in) |                     |                       | 208 mm<br>(8.189 in) |                      |                      |
| 4200-6503   |              |                       |                       |                      | 100 mm<br>(3.937 in) | 65 mm<br>(2.559 in) |                     |                       | 249 mm<br>(9.803 in) |                      |                      |
| 4200-6504   |              |                       |                       |                      | 150 mm<br>(5.906 in) | 90 mm<br>(3.543in)  |                     |                       | 65 mm<br>(2.559 in)  | 2 mm<br>(0.079 in)   | 207 mm<br>(8.150 in) |
| 4200-6405   | Epcos        | 260 mm<br>(10.236 in) | 275 mm<br>(10.827 in) | 170 mm<br>(6.693 in) | 90 mm<br>(3.543in)   | 65 mm<br>(2.559 in) | 2 mm<br>(0.079 in)  | 300 mm<br>(11.811 in) | 205 mm<br>(8.071 in) |                      |                      |
| 4200-6407   |              |                       |                       |                      | 120 mm<br>(4.724 in) | 85 mm<br>(3.346 in) |                     |                       | 1 mm<br>(0.039 in)   | 249 mm<br>(9.803 in) |                      |
| 4200-6501   |              |                       |                       |                      |                      |                     |                     |                       |                      |                      |                      |
| 4200-6502   |              |                       |                       |                      |                      |                     |                     |                       |                      |                      |                      |

**Figure 3-54 Size 6 external EMC filter**



| CT part no. | Manufacturer | A                    | B                      | C                    | D                    | E                    | F                  | G                   | H                    | I                    | J                     | W                     |
|-------------|--------------|----------------------|------------------------|----------------------|----------------------|----------------------|--------------------|---------------------|----------------------|----------------------|-----------------------|-----------------------|
| 4200-6603   | Schaffner    | 196 mm<br>(7.717 in) | 139.9 mm<br>(5.508 in) | 108 mm<br>(4.252 in) | 230 mm<br>(9.055 in) | 210 mm<br>(8.268 in) | 2 mm<br>(0.079 in) | 38 mm<br>(1.496 in) | 136 mm<br>(5.354 in) | 128 mm<br>(5.039 in) | 53.5 mm<br>(2.106 in) | 364 mm<br>(14.331 in) |

### 3.13 Heatsink mounted braking resistor



If the drive has been used at high load levels for a period of time, the heatsink and heatsink mounted braking resistor can reach temperatures in excess of 70°C (158°F). Human contact with the heatsink and heatsink mounted braking resistor should be prevented.



To avoid the risk of fire when the drive is surface mounted with the braking resistor fitted, the back plate should be a non-flammable material.

The Unidrive SP size 1 and 2 have been designed with an optional space-saving heatsink mounted resistor. The resistor can be fitted within the heatsink fins of the drive. When the heatsink mounted resistor is used, an external thermal protection device is not required as the resistor is designed such that it will fail safely under fault conditions. The in-built software overload protection is set up at default to protect the resistor. The resistor is rated to IP54 (NEMA12).

If the drive is to be through-panel mounted with the heatsink mounted brake resistor fitted, then the aperture in the panel through which the drive is mounted must be modified as shown in Figure 3-55 and Figure 3-56. This is in order to allow for the braking resistor cables and grommets.

Figure 3-55 Through-panel mounting cut-out details for size 1

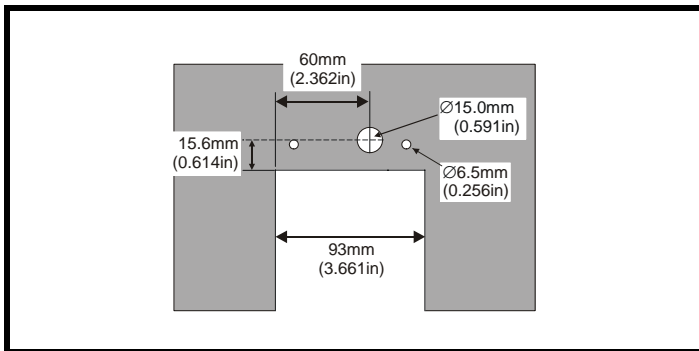
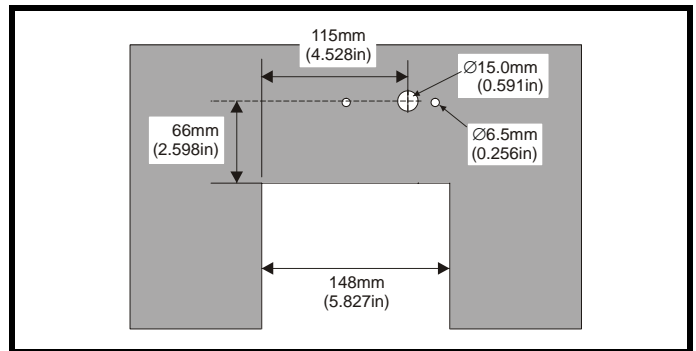


Figure 3-56 Through-panel mounting cut-out details for size 2



The part numbers for the resistor kits are as follows:

Size 1: 1220-2756-01

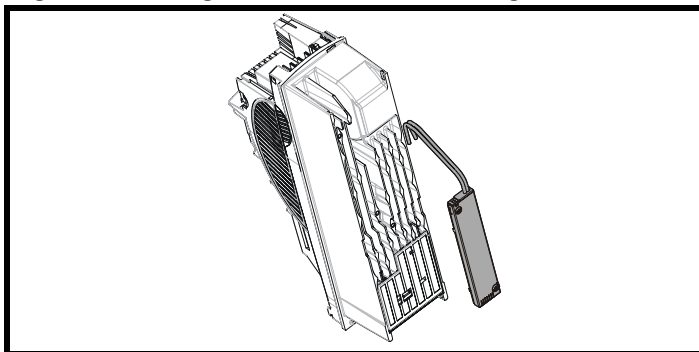
Size 2: 1220-2758-01

Each kit contains the following:

- A braking resistor assembly
- A through-panel grommet
- An installation sheet
- A wire clip (Size 2 only)

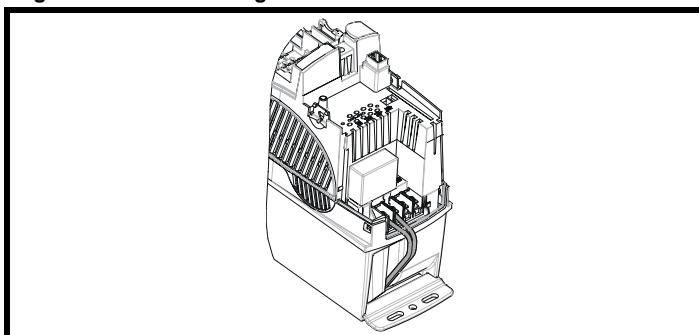
#### 3.13.1 Size 1 braking resistor fitting instructions

Figure 3-57 Fitting the heatsink mounted braking resistor on size 1



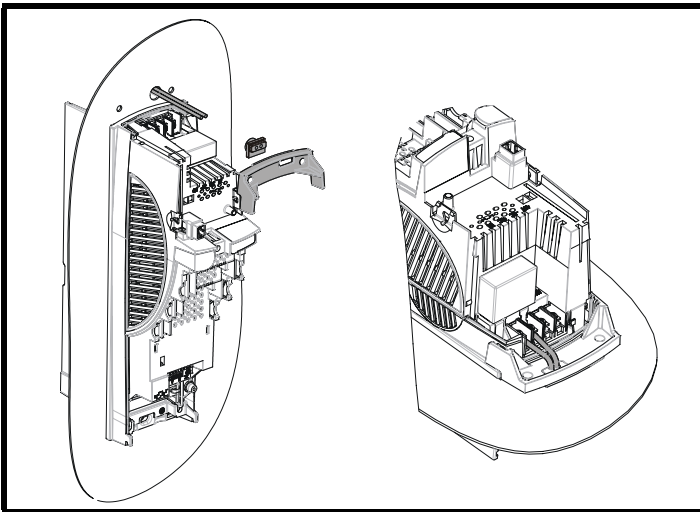
- Remove both terminal covers as detailed in section 3.3.1 *Removing the terminal covers* on page 26.
- Remove the two break-outs that line-up with the BR and +DC terminal connections as detailed in section 3.4.4 *Removing the finger-guard and DC terminal cover break-outs* on page 36.
- Fit the braking resistor to the heatsink as shown in Figure 3-57. The resistor is fitted with captive screws.
- The screws should be tightened to a maximum torque of 2 N m (1.5 lb ft).
- Ensure the cables are routed between the fins of the heatsink, and that the cables are not trapped between heatsink fins and the resistor.

Figure 3-58 Connecting the brake resistor on a surface mounted size 1



- Fit the DC terminal cover grommets supplied in the accessory box with the drive, to the cables. To ensure a good seal, the grommets are a tight fit. Lubrication may be required to help fit the grommets to the cables.
- Terminate the cables with suitable crimps and connect to the BR and +DC terminals. Tighten the screw terminals to a maximum torque of 1.5 Nm (1.1 lb ft).
- Replace both terminal covers.

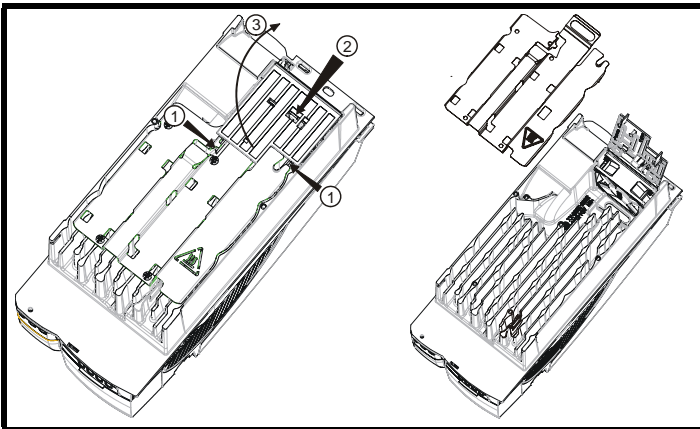
**Figure 3-59 Connecting the brake resistor on a through-panel mounted size 1**



- See Figure 3-55 for through-panel mounting cut-out details.
- Pass the cables through the hole in the panel and fit the through-panel grommet.
- Fit the through-panel mounting bracket.
- Fit the DC terminal cover grommets supplied in the accessory box with the drive, to the cables. To ensure a good seal, the grommets are a tight fit. Lubrication may be required to help fit the grommets to the cables.
- Terminate the cables with suitable crimps and connect to the BR and +DC terminals. Tighten the screw terminals to a maximum torque of 1.5 Nm (1.1 lb ft).
- Replace both terminal covers.

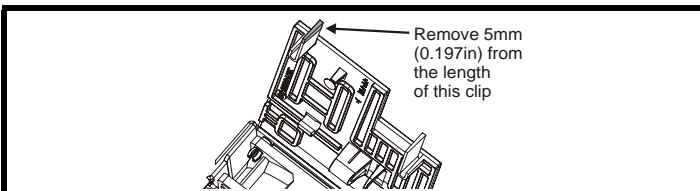
### 3.13.2 Size 2 braking resistor fitting instructions

**Figure 3-60 Removing the baffle plate on a size 2**



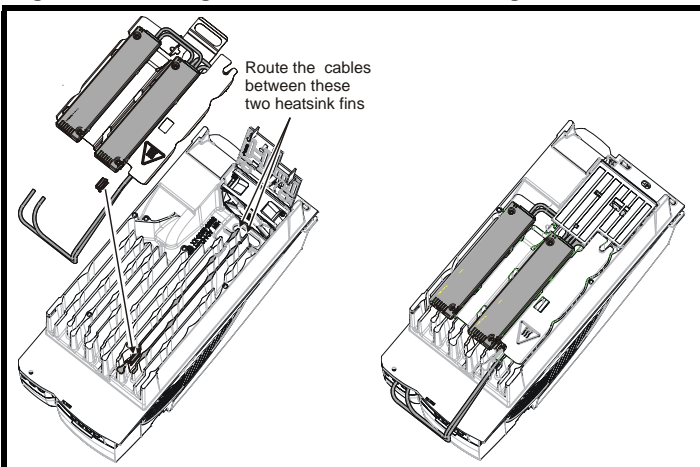
- Remove the DC cover as detailed in section 3.3.1 *Removing the terminal covers* on page 26.
- Remove the two break-outs that line-up with the BR and +DC terminal connections as detailed in section 3.4.4 *Removing the finger-guard and DC terminal cover break-outs* on page 36.
- Lift the hinged fan baffle by pushing plastic tabs in the direction shown (1). Push tab in the direction shown (2), and lift the baffle as shown (3).
- Remove the metal heatsink baffle plate by removing the two screws. These two screws are no longer required.

**Figure 3-61 Modifying the fan baffle on a size 2**



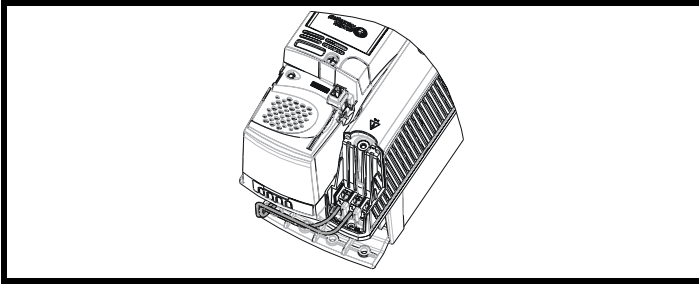
- Remove 5mm (0.197in) from the length of the clip on the plastic fan baffle.

**Figure 3-62 Fitting the heatsink mounted braking resistor on a size 2**



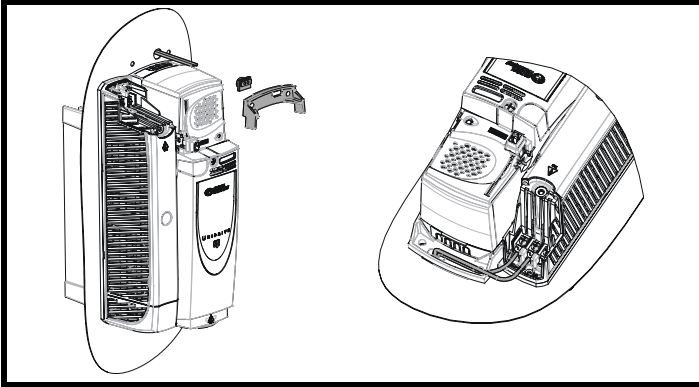
- Fit clip to heatsink in the position shown in diagram opposite. Route the long cables of the resistor assembly between the fins of the heatsink as shown in Figure 3-62.
- Fit the heatsink baffle plate in place with the cables routed underneath. Ensure the cables are not trapped between a heatsink fin and the baffle plate.
- Fit the braking resistors to the heatsink. The resistors are fitted with captive screws.
- The screws should be tightened to a maximum torque of 2.0 N m (1.5 lb ft).
- Close the hinged fan baffle.
- Fit cables to heatsink clip.

**Figure 3-63 Connecting the brake resistor on a surface mounted size 2**



- Fit the DC terminal cover grommets supplied in the accessory box with the drive, to the cables. To ensure a good seal, the grommets are a tight fit. Lubrication may be required to help fit the grommets to the cables.
- Terminate the cables with suitable crimps and connect to the BR and DC2 terminals.
- Replace the terminal cover.

**Figure 3-64 Connecting the brake resistor on a through-panel mounted size 2**



- See Figure 3-56 for through-panel mounting cut-out details.
- Pass the cables through the hole in the panel and fit the hole grommet.
- Fit the mounting bracket.
- Fit the DC terminal cover grommets supplied in the accessory box with the drive, to the cables. To ensure a good seal, the grommets are a tight fit. Lubrication may be required to help fit the grommets to the cables.
- Terminate the cables with suitable crimps and connect to the BR and DC2 terminals.
- Replace the terminal cover.



### 3.13.3 Braking resistor overload protection parameter settings

#### Failure to observe the following information may damage the resistor.

The Unidrive SP software contains an overload protection function for a braking resistor. On Unidrive SP size 1 and 2 this function is enabled at default to protect the heatsink mounted resistor. Below are the parameter settings.

| Parameter                 |          | 200V drive | 400V drive |
|---------------------------|----------|------------|------------|
| Full power braking time   | Pr 10.30 | 0.09       | 0.02       |
| Full power braking period | Pr 10.31 | 2.0        |            |

For more information on the braking resistor software overload protection, see the *Unidrive SP Advanced User Guide*.

If the heatsink mounted braking resistor is to be used at more than half of its average power rating then the drive's cooling fan must be set to full speed by setting Pr 6.45 to On (1).

See section 4.9.1 *Heatsink mounted braking resistor* on page 80 for the resistor specifications.

### 3.14 Electrical terminals

#### 3.14.1 Location of the power and ground terminals

Figure 3-65 Locations of the power and ground terminals on wall mounted drives

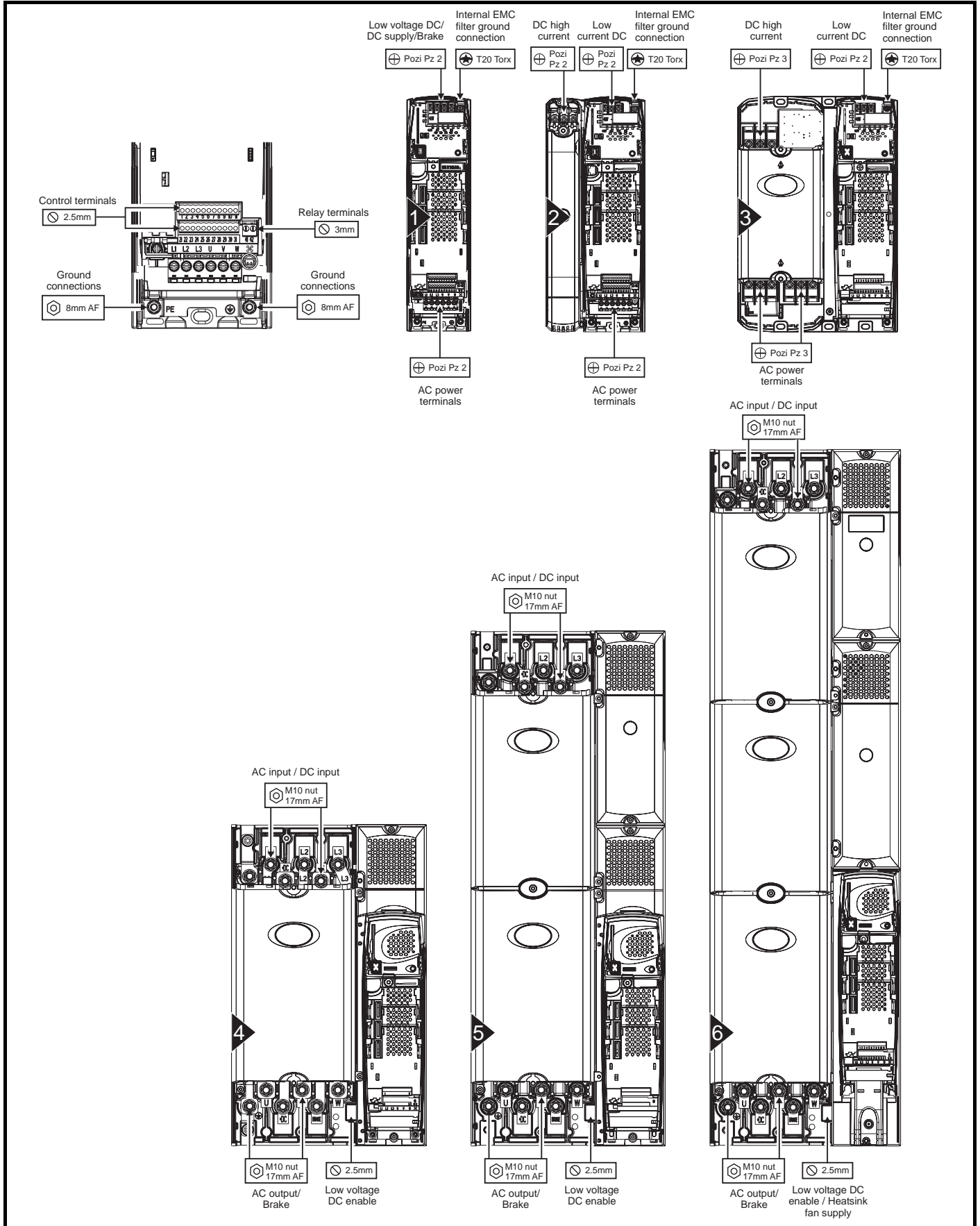
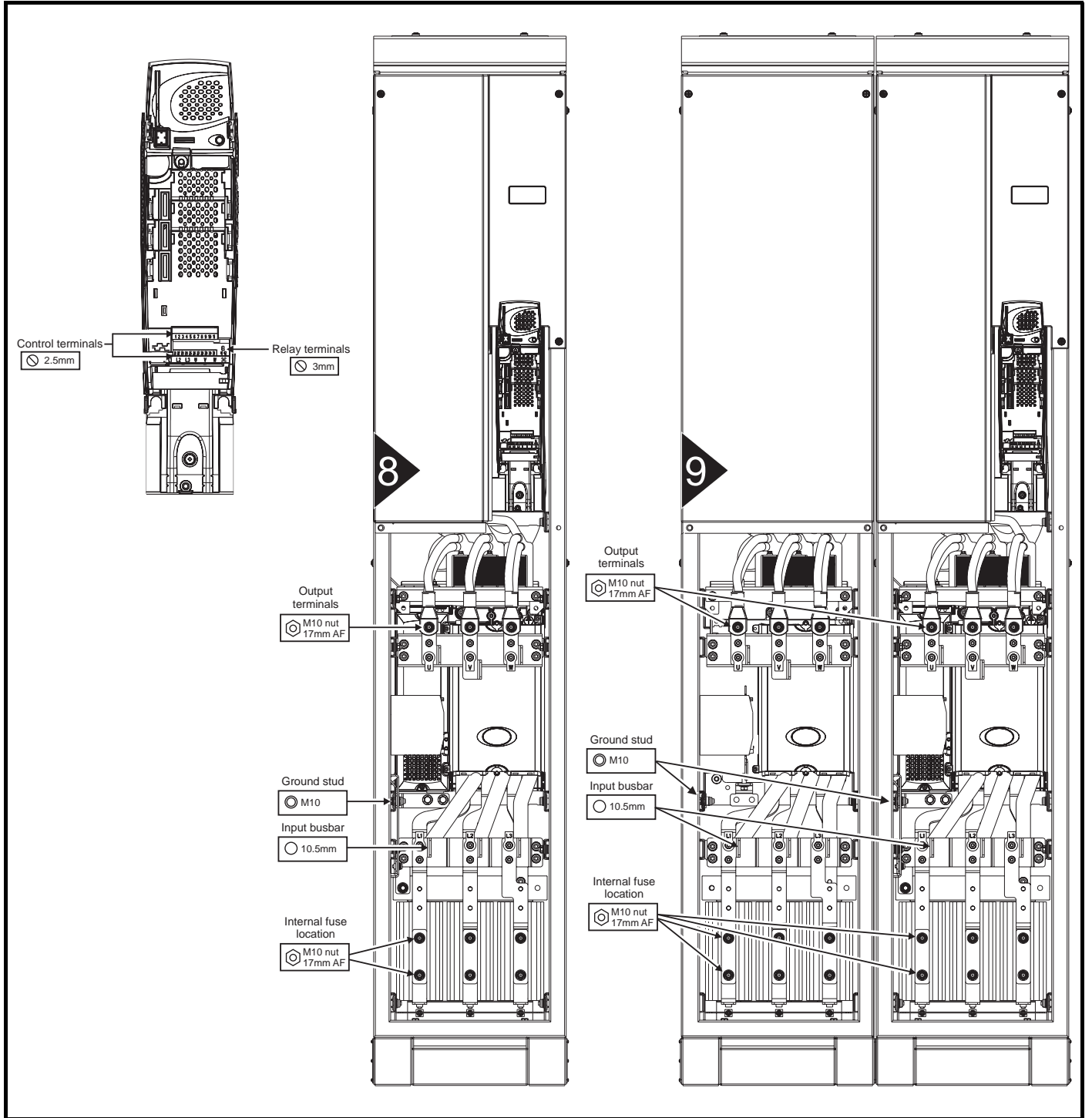


Figure 3-66 Locations of the power and ground terminals on free standing cubicle drives



### 3.14.2 Terminal sizes and torque settings



To avoid a fire hazard and maintain validity of the UL listing, adhere to the specified tightening torques for the power and ground terminals. Refer to the following tables.

**Table 3-6 Drive control and relay terminal data**

| Model | Connection type        | Torque setting      |
|-------|------------------------|---------------------|
| All   | Plug-in terminal block | 0.5 N m (0.4 lb ft) |

**Table 3-7 Wall mounted drive power terminal data**

| Model size       | AC terminals                                    | High current DC and braking                       | Low voltage DC                                    | Ground terminal                   |
|------------------|---|---|---|-----------------------------------|
| 1                | Plug-in terminal block<br>1.5 N m (1.1 lb ft)   | Terminal block (M4 screws)<br>1.5 N m (1.1 lb ft) |   | Stud (M5)<br>4.0 N m<br>2.9 lb ft |
| 2                |   | Terminal block (M5 screws)<br>1.5 N m (1.1 lb ft) | Terminal block (M4 screws)<br>1.5 N m (1.1 lb ft) |                                   |
| 3                | Terminal block (M6 screws)<br>2.5 N m 1.8 lb ft |   |   | 6.0 N m<br>4.4 lb ft              |
| 4                | M10 stud<br>15 N m<br>(11.1 lb ft)              |   |   | M10 stud                          |
| 5                |   |   |   | 12 N m                            |
| 6                |   |   |   | (8.8 lb ft)                       |
| Torque tolerance |   |   |   | ±10%                              |

**Table 3-8 Free standing cubicle drive terminal data**

| Model size       | AC terminals   | High current DC and braking | Internal fuse         | Ground terminal |
|------------------|--|-----------------------------|-----------------------|-----------------|
| 8                | 2 x M10 clearance holes per phase for parallel cables. |                             | 12 N m<br>(8.8 lb ft) |                 |
| 9                |  |                             |                       |                 |
| Torque tolerance |  |                             |                       | ±10%            |

**Table 3-9 Schaffner external EMC filter terminal data**

| CT part number | Power connections           |                     | Ground connections |                     |
|----------------|-----------------------------|---------------------|--------------------|---------------------|
|                | Max cable size              | Max torque          | Ground stud size   | Max torque          |
| 4200-6118      | 4mm <sup>2</sup>            | 0.8 N m (0.6 lb ft) | M5                 | 3.5 N m (2.6 lb ft) |
| 4200-6119      | 12AWG                       |                     |                    |                     |
| 4200-6210      | 10mm <sup>2</sup><br>8AWG   | 2 N m (1.5 lb ft)   | M5                 | 3.5 N m (2.6 lb ft) |
| 4200-6305      | 16mm <sup>2</sup><br>6AWG   | 2.2 N m (1.6 lb ft) | M6                 | 3.9 N m (2.9 lb ft) |
| 4200-6307      |                             |                     |                    |                     |
| 4200-6309      |                             |                     |                    |                     |
| 4200-6406      | 50mm <sup>2</sup><br>0AWG   | 8 N m (5.9 lb ft)   | M10                | 25 N m (18.4 lb ft) |
| 4200-6408      | 25mm <sup>2</sup><br>4AWG   | 2.3 N m (1.7 lb ft) | M6                 | 3.9 N m (2.9 lb ft) |
| 4200-6503      | 95mm <sup>2</sup><br>4/0AWG | 20 N m (14.7 lb ft) | M10                | 25 N m (18.4 lb ft) |
| 4200-6504      | 50mm <sup>2</sup><br>0AWG   | 8 N m (5.9 lb ft)   | M10                | 25 N m (18.4 lb ft) |
| 4200-6603      |                             |                     | M10                | 25 N m (18.4 lb ft) |
| 4200-6604      |                             |                     |                    |                     |

**Table 3-10 Epcos external EMC Filter terminal data**

| CT part number | Power connections         |                      | Ground connections |                     |
|----------------|---------------------------|----------------------|--------------------|---------------------|
|                | Max cable size            | Max torque           | Ground stud size   | Max torque          |
| 4200-6120      | 4mm <sup>2</sup>          | 0.6 N m (0.4 lb ft)  | M5                 | 3.0 N m (2.2 lb ft) |
| 4200-6121      | 12AWG                     |                      |                    |                     |
| 4200-6211      | 10mm <sup>2</sup><br>8AWG | 1.35 N m (1.0 lb ft) | M5                 | 3.0 N m (2.2 lb ft) |
| 4200-6306      | 16mm <sup>2</sup><br>6AWG | 2.2 N m (1.6 lb ft)  | M6                 | 5.1 N m (3.8 lb ft) |
| 4200-6308      | 10mm <sup>2</sup><br>8AWG | 1.35 N m (1.0 lb ft) |                    |                     |
| 4200-6405      | 50mm <sup>2</sup>         | 6.8 N m (5.0 lb ft)  | M10                | 10 N m (7.4 lb ft)  |
| 4200-6407      | 0AWG                      |                      |                    |                     |
| 4200-6501      | 95mm <sup>2</sup>         | 20 N m (14.7 lb ft)  |                    |                     |
| 4200-6502      | 4/0AWG                    |                      |                    |                     |
| 4200-6601      |                           |                      |                    |                     |
| 4200-6602      |                           |                      |                    |                     |

### 3.15 Routine maintenance

The drive should be installed in a cool, clean, well ventilated location. Contact of moisture and dust with the drive should be prevented.

Regular checks of the following should be carried out to ensure drive / installation reliability are maximised:

| Environment            |  |
|------------------------|--|
| Ambient temperature    | Ensure the enclosure temperature remains at or below maximum specified   |
| Dust                   | Ensure the drive remains dust free – check that the heatsink and drive fan are not gathering dust. The lifetime of the fan is reduced in dusty environments. |
| Moisture               | Ensure the drive enclosure shows no signs of condensation  |
| Enclosure              |  |
| Enclosure door filters | Ensure filters are not blocked and that air is free to flow  |
| Electrical             |  |
| Screw connections      | Ensure all screw terminals remain tight  |
| Crimp terminals        | Ensure all crimp terminals remains tight – check for any discolouration which could indicate overheating   |
| Cables                 | Check all cables for signs of damage   |

## 4 Electrical Installation

Many cable management features have been incorporated into the product and accessories, this chapter shows how to optimise them. Key features include:

- SECURE DISABLE function
- Internal EMC filter
- EMC compliance with shielding / grounding accessories
- Product rating, fusing and cabling information
- Brake resistor details (selection / ratings)

**Electric shock risk**  
 The voltages present in the following locations can cause severe electric shock and may be lethal:

- AC supply cables and connections
- DC and brake cables, and connections
- Output cables and connections
- Many internal parts of the drive, and external option units

Unless otherwise indicated, control terminals are single insulated and must not be touched.

**Isolation device**  
 The AC supply must be disconnected from the drive using an approved isolation device before any cover is removed from the drive or before any servicing work is performed.

**STOP function**  
 The STOP function does not remove dangerous voltages from the drive, the motor or any external option units.

**SECURE DISABLE function**  
 The SECURE DISABLE function does not remove dangerous voltages from the drive, the motor or any external option units.

**Stored charge**  
 The drive contains capacitors that remain charged to a potentially lethal voltage after the AC supply has been disconnected. If the drive has been energised, the AC supply must be isolated at least ten minutes before work may continue.

Normally, the capacitors are discharged by an internal resistor. Under certain, unusual fault conditions, it is possible that the capacitors may fail to discharge, or be prevented from being discharged by a voltage applied to the output terminals. If the drive has failed in a manner that causes the display to go blank immediately, it is possible the capacitors will not be discharged. In this case, consult Control Techniques or their authorised distributor.

**Equipment supplied by plug and socket**  
 Special attention must be given if the drive is installed in equipment which is connected to the AC supply by a plug and socket. The AC supply terminals of the drive are connected to the internal capacitors through rectifier diodes which are not intended to give safety isolation. If the plug terminals can be touched when the plug is disconnected from the socket, a means of automatically isolating the plug from the drive must be used (e.g. a latching relay).

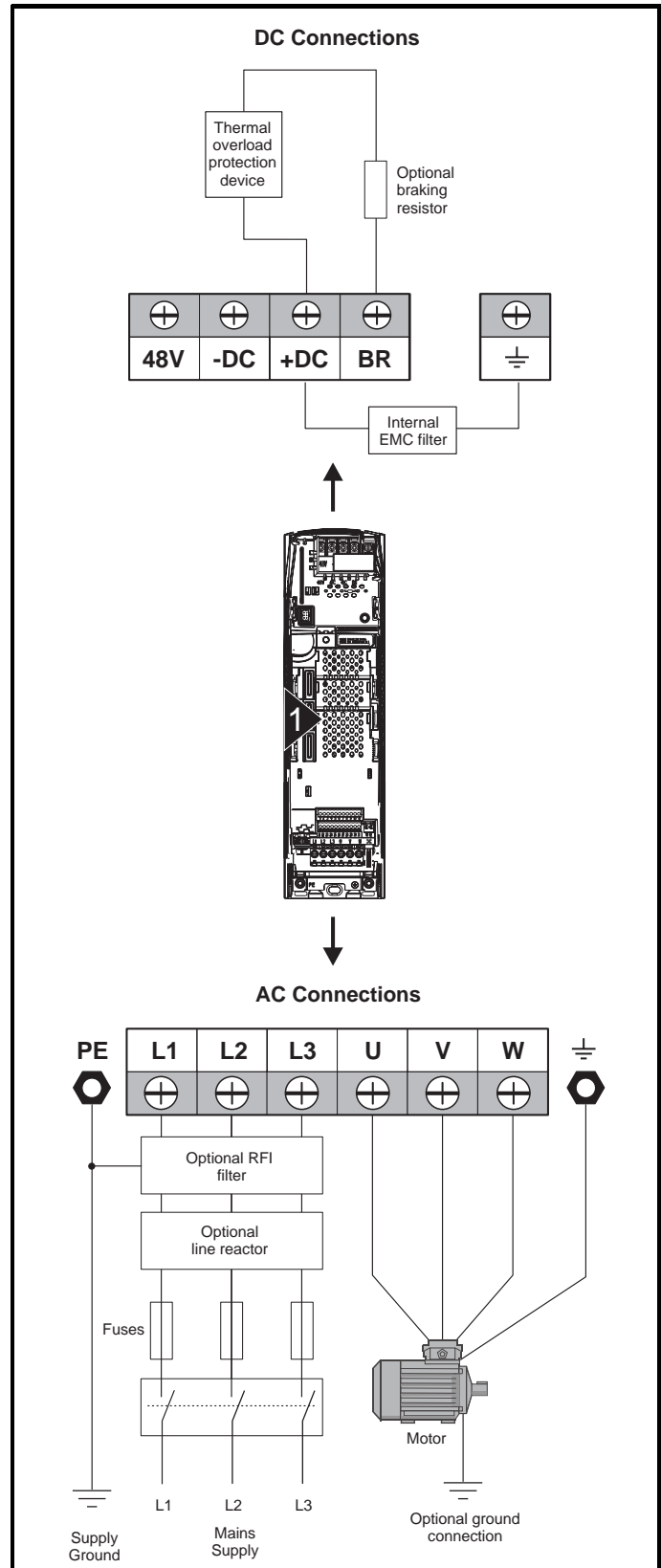
**Permanent magnet motors**  
 Permanent magnet motors generate electrical power if they are rotated, even when the supply to the drive is disconnected. If that happens then the drive will become energised through its motor terminals.

If the motor load is capable of rotating the motor when the supply is disconnected, then the motor must be isolated from the drive before gaining access to any live parts.

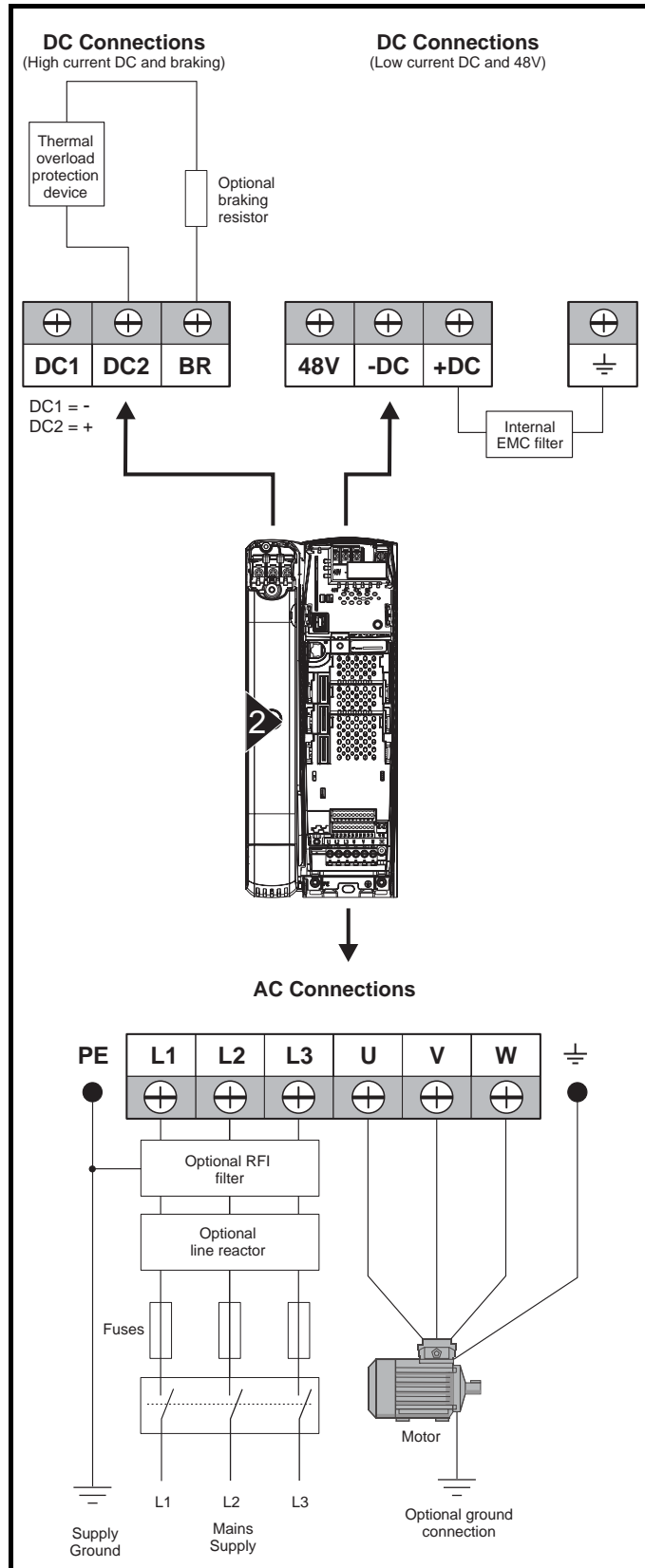
## 4.1 Power connections

### 4.1.1 AC and DC connections

Figure 4-1 Unidrive SP size 1 power connections



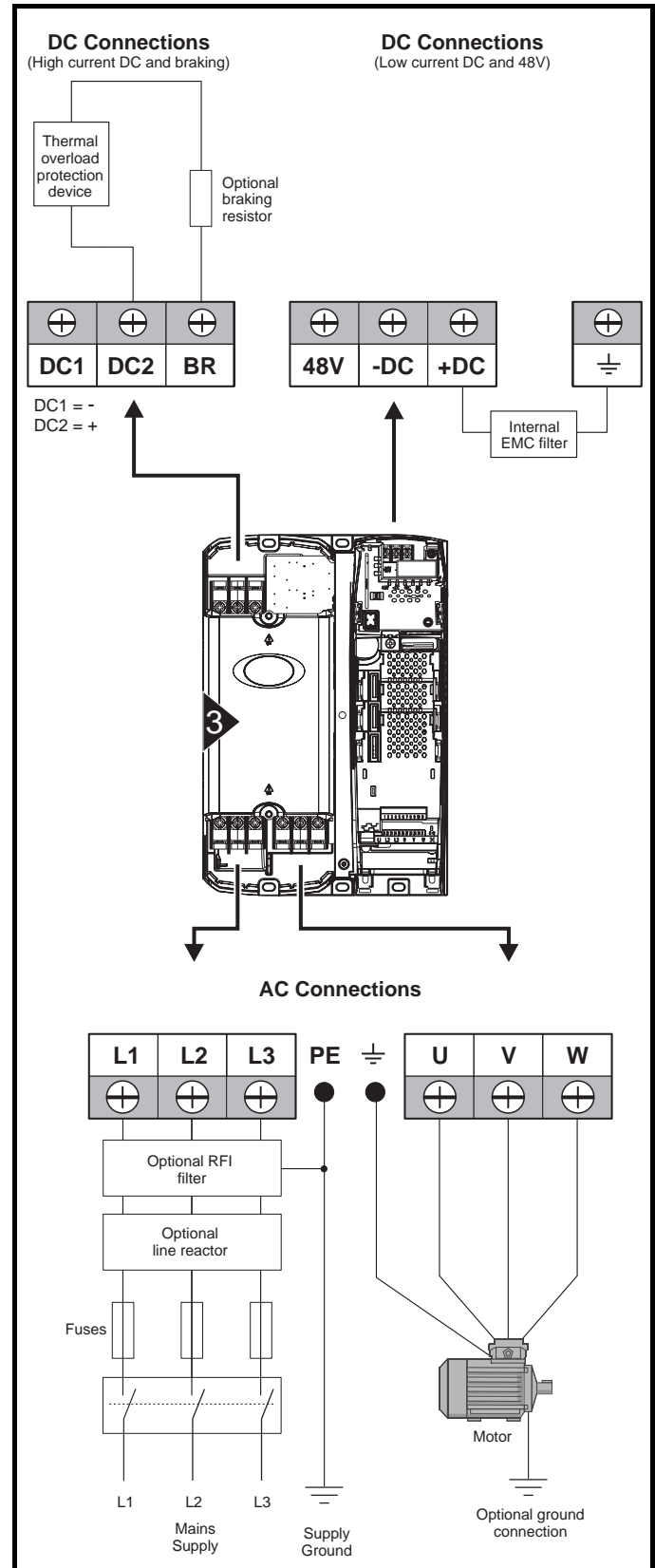
**Figure 4-2 Unidrive SP size 2 power connections**



If the heatsink mounted resistor is used (size 1 and 2 only), an overload protection device is not required. The resistor is designed to fail safely under fault conditions.

See Figure 4-7 for further information on ground connections.

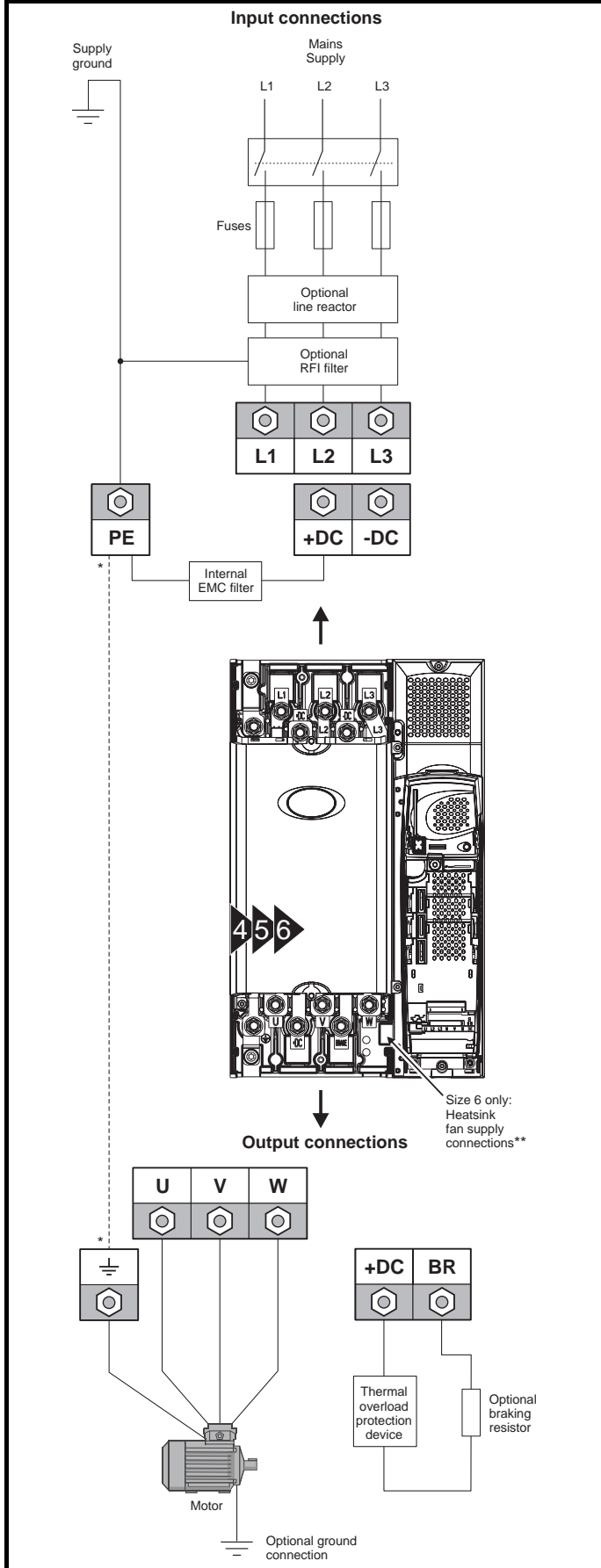
**Figure 4-3 Unidrive SP size 3 power connections**



On Unidrive SP size 2 and 3, the high current DC connections must always be used when using a braking resistor, supplying the drive from DC (low voltage DC or high voltage DC) or using the drive in a parallel DC bus system. The low current DC connection is used to connect low voltage DC to the drive internal power supply and to connect the internal EMC filter.

See Figure 4-8 for further information on ground connections.

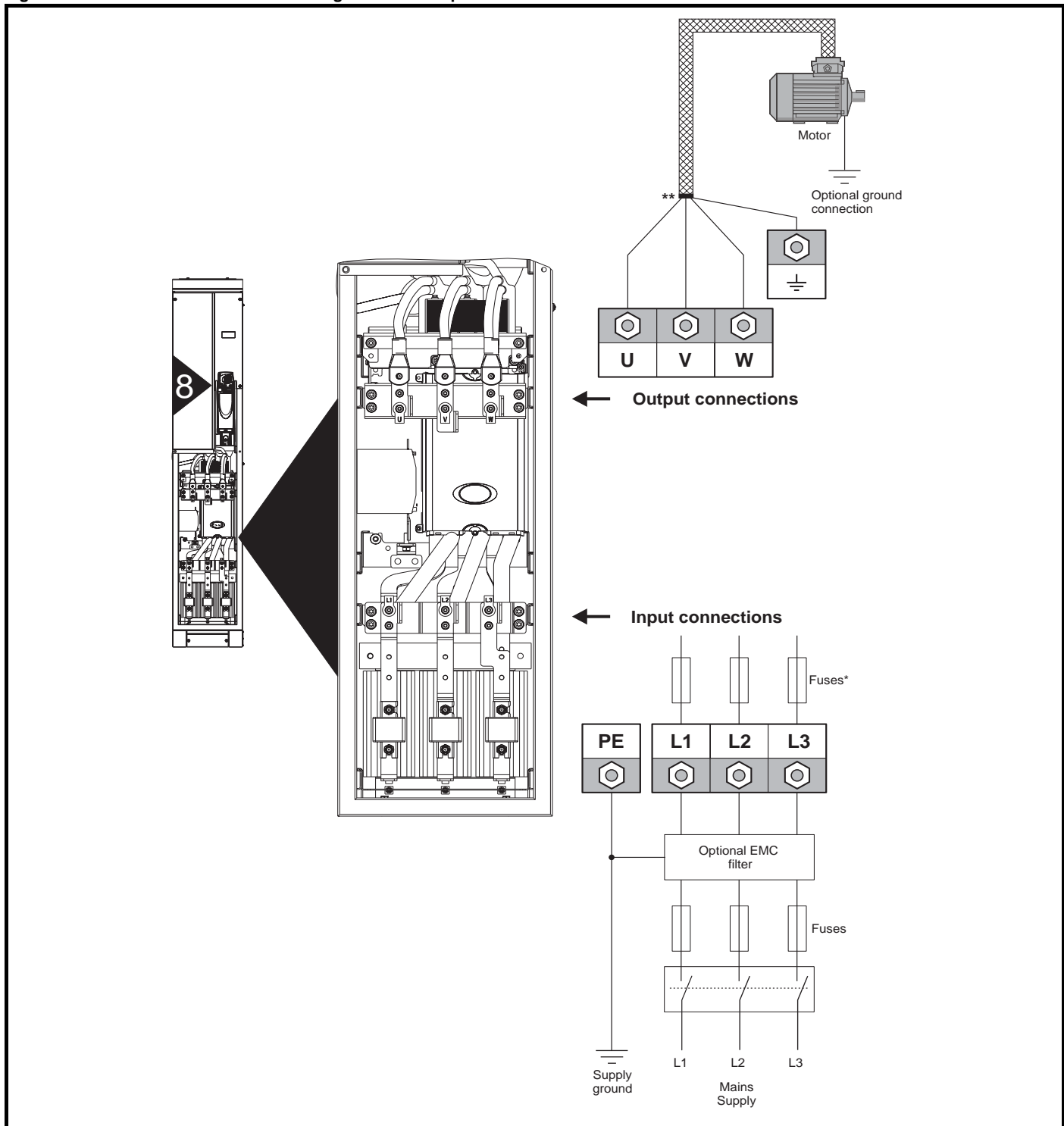
**Figure 4-4 Unidrive SP size 4, 5 and 6 power connections**



\* See section 4.1.2 *Ground connections* .

\*\* See section 4.4 *Heatsink fan supply* on page 73 for more information.

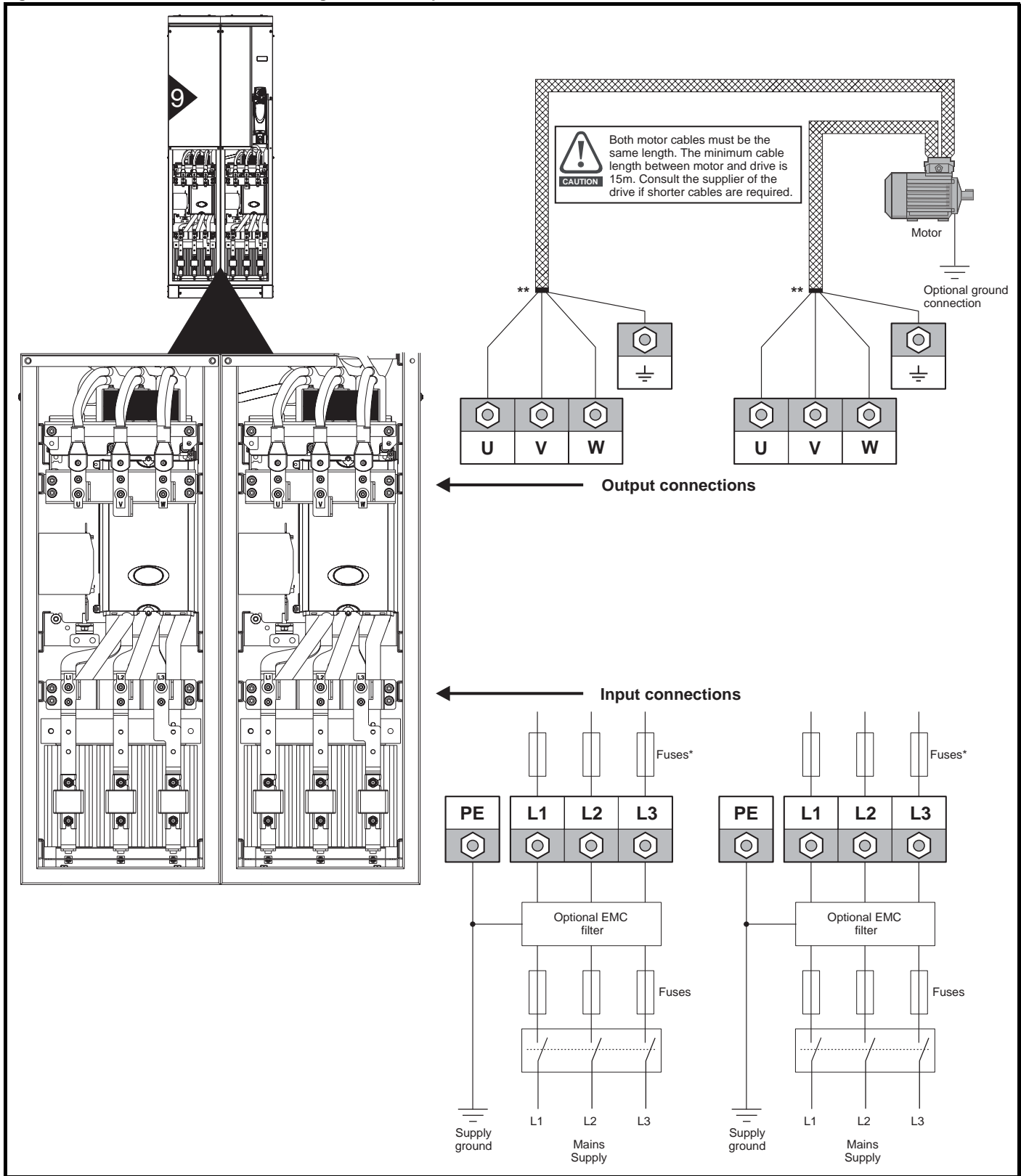
**Figure 4-5 Unidrive SP size 8 free standing cubicle drive power connections**



\*Cubicles are supplied without internal fuses as standard, the user must fit them during installation. Fuses may be bought from Control Techniques, see Table 4-5 on page 77 for further information.

\*\*Cable shield must be bonded to gland plate.

**Figure 4-6 Unidrive SP size 9 free standing cubicle drive power connections**



\*Cubicles are supplied without internal fuses as standard, the user must fit them during installation. Fuses may be bought from Control Techniques, see Table 4-5 on page 77 for further information.

\*\*Cable shield must be bonded to gland plate.

## 4.1.2 Ground connections

### Size 1

On a Unidrive SP size 1, the supply and motor ground connections are made using the studs located either side of the drive near the plug-in power connector. Refer to Figure 4-1 on page 66.

### Size 2

On a Unidrive SP size 2, the supply and motor ground connections are made using the grounding bridge that locates at the bottom of the drive. See Figure 4-7 for details.

### Size 3

On a Unidrive SP size 3, the supply and motor ground connections are made using an M6 nut and bolt that locates in the fork protruding from the heatsink between the AC supply and motor output terminals. See Figure 4-8 for details.

### Size 4, 5 and 6

On a Unidrive SP size 4, 5 and 6, the supply and motor ground connections are made using an M10 bolt at the top (supply) and bottom (motor) of the drive. See Figure 4-9 on page 71.

The supply ground and motor ground connections to the drive are connected internally by a copper conductor with a cross-sectional area given below:

Size 4: 19.2mm<sup>2</sup> (0.03in<sup>2</sup>, or slightly bigger than 6 AWG)

Size 5: 60mm<sup>2</sup> (0.09in<sup>2</sup>, or slightly bigger than 1 AWG)

Size 6: 75mm<sup>2</sup> (0.12in<sup>2</sup>, or slightly bigger than 2/0 AWG)

This connection is sufficient to provide the ground (equipotential bonding) connection for the motor circuit under the following conditions:

| To standard              | Conditions  |
|--------------------------|---|
| IEC 60204-1 & EN 60204-1 | Supply phase conductors having cross-sectional area not exceeding:<br>Size 4: 38.4mm <sup>2</sup><br>Size 5: 120mm <sup>2</sup><br>Size 6: 150mm <sup>2</sup> |
| NFPA 79                  | Supply protection device rating not exceeding:<br>Size 4: 200A<br>Size 5: 600A<br>Size 6: 1000A   |

If the necessary conditions are not met, an additional ground connection must be provided to link the motor circuit ground and the supply ground.

Figure 4-7 Unidrive SP size 2 ground connections

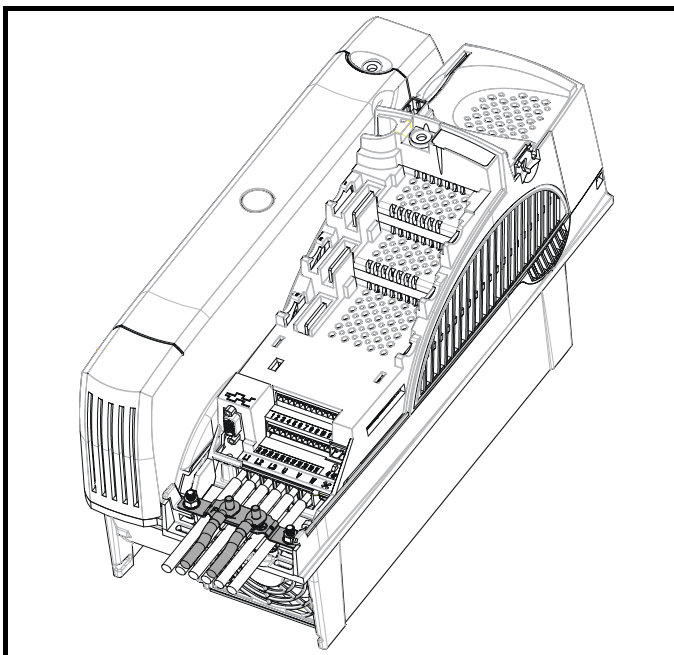


Figure 4-8 Unidrive SP size 3 ground connections

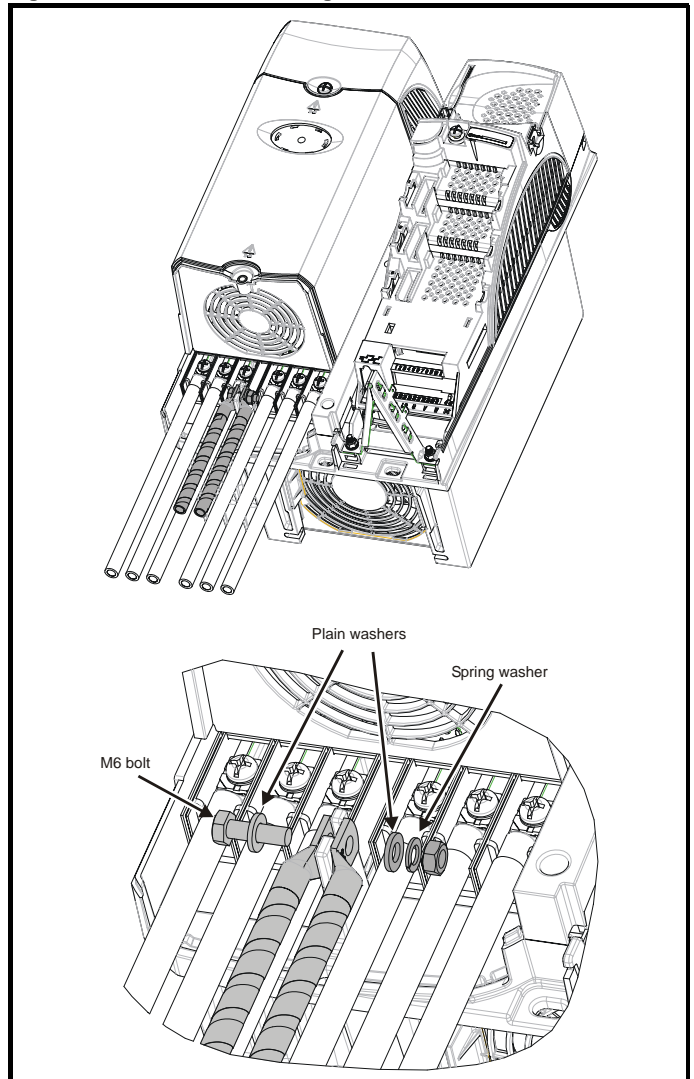
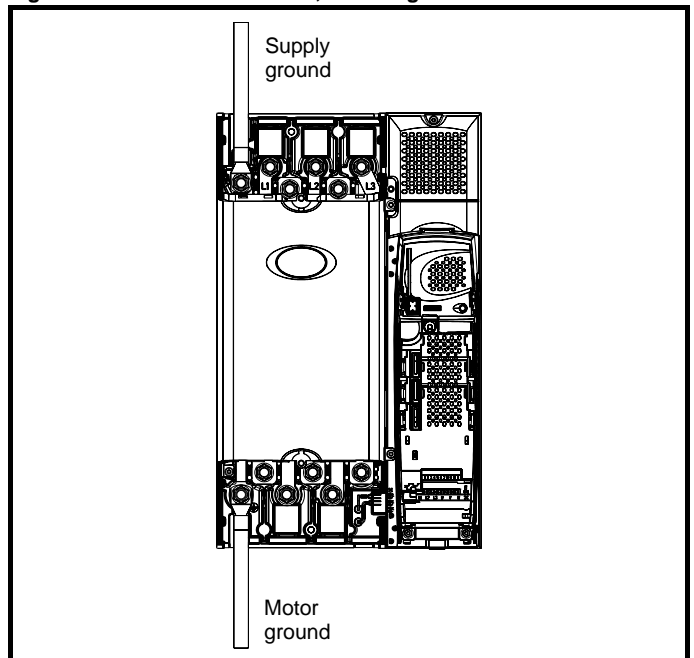
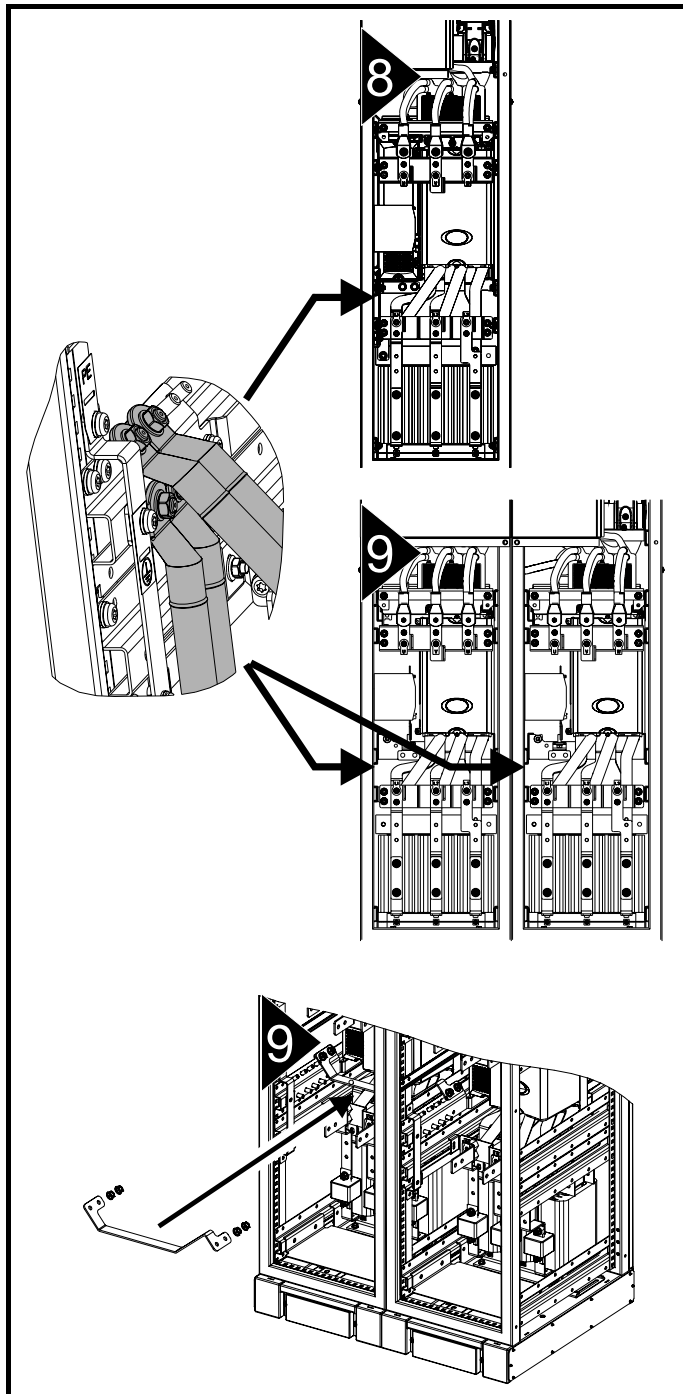


Figure 4-9 Unidrive SP size 4, 5 and 6 ground connections



**Figure 4-10 Unidrive SP size 8 and 9 free standing cubicle ground connections**



**WARNING**

The ground loop impedance must conform to the requirements of local safety regulations.

The drive must be grounded by a connection capable of carrying the prospective fault current until the protective device (fuse, etc.) disconnects the AC supply.

The ground connections must be inspected and tested at appropriate intervals.

## 4.2 AC supply requirements

Voltage:

|        |                   |
|--------|-------------------|
| SPX20X | 200V to 240V ±10% |
| SPX40X | 380V to 480V ±10% |
| SPX50X | 500V to 575V ±10% |
| SPX60X | 500V to 690V ±10% |

Number of phases: 3

Maximum supply imbalance: 2% negative phase sequence (equivalent to 3% voltage imbalance between phases).

Frequency range: 48 to 65 Hz

For UL compliance only, the maximum supply symmetrical fault current must be limited to 100kA

### 4.2.1 Supply types

Drives rated for supply voltage up to 575V are suitable for use with any supply type, i.e. TN-S, TN-C-S, TT, IT, with grounding at any potential, i.e. neutral, centre or corner ("grounded-delta").

Grounded delta supplies >575V are not permitted.

Drives are suitable for use on supplies of installation category III and lower, according to IEC60664-1. This means they may be connected permanently to the supply at its origin in a building, but for outdoor installation additional over-voltage suppression (transient voltage surge suppression) must be provided to reduce category IV to category III.



#### Operation with IT (ungrounded) supplies:

Special attention is required when using internal or external EMC filters with ungrounded supplies, because in the event of a ground (earth) fault in the motor circuit the drive may not trip and the filter could be over-stressed. In this case, either the filter must not be used (removed) or additional independent motor ground fault protection must be provided. Refer to Table 4-1.

For instructions on removal, refer to Figure 4-24 *Removal of internal EMC filter (size 1 to 3)* and Figure 4-25 *Removal of internal EMC filter (sizes 4 to 6)* on page 84.

For details of ground fault protection contact the supplier of the drive.

A ground fault in the supply has no effect in any case. If the motor must continue to run with a ground fault in its own circuit then an input isolating transformer must be provided and if an EMC filter is required it must be located in the primary circuit.

Unusual hazards can occur on ungrounded supplies with more than one source, for example on ships. Contact the supplier of the drive for more information.

**Table 4-1 Behaviour of the drive in the event of a motor circuit ground (earth) fault with an IT supply**

| Drive size | Internal filter only                | External filter (with internal)     |
|------------|-------------------------------------|-------------------------------------|
| 1 & 2      | Drive trips on fault                | Drive trips on fault                |
| 3          | May not trip – precautions required | Drive trips on fault                |
| 4 to 6     | May not trip – precautions required | May not trip – precautions required |

### 4.2.2 Supplies requiring line reactors

Input line reactors reduce the risk of damage to the drive resulting from poor phase balance or severe disturbances on the supply network.

Where line reactors are to be used, reactance values of approximately 2% are recommended. Higher values may be used if necessary, but may result in a loss of drive output (reduced torque at high speed) because of the voltage drop.

For all drive ratings, 2% line reactors permit drives to be used with a supply unbalance of up to 3.5% negative phase sequence (equivalent to 5% voltage imbalance between phases).

Severe disturbances may be caused by the following factors, for example:

- Power factor correction equipment connected close to the drive.

- Large DC drives having no or inadequate line reactors connected to the supply.
- Direct-on-line started motor(s) connected to the supply such that when any of these motors are started, the voltage dip exceeds 20%.

Such disturbances may cause excessive peak currents to flow in the input power circuit of the drive. This may cause nuisance tripping, or in extreme cases, failure of the drive.

Drives of low power rating may also be susceptible to disturbance when connected to supplies with a high rated capacity.

Line reactors are particularly recommended for use with the following drive models when one of the above factors exists, or when the supply capacity exceeds 175kVA:

SP1201 SP1202 SP1203 SP1204  
 SP1401 SP1402 SP1403 SP1404

Model sizes SP1405 to SP4606 have an internal DC choke and SP5401 to SP6602 have internal AC line chokes, so they do not require AC line reactors except for cases of excessive phase unbalance or extreme supply conditions.

When required, each drive must have its own reactor(s). Three individual reactors or a single three-phase reactor should be used.

### Reactor current ratings

The current rating of the line reactors should be as follows:

Continuous current rating:

Not less than the continuous input current rating of the drive

Repetitive peak current rating:

Not less than twice the continuous input current rating of the drive

### 4.2.3 Input inductor calculation.

To calculate the inductance required (at Y%), use the following equation:

$$L = \frac{Y}{100} \times \frac{V}{\sqrt{3}} \times \frac{1}{2\pi f I}$$

Where:

- I = drive rated input current (A)
- L = inductance (H)
- f = supply frequency (Hz)
- V = voltage between lines

## 4.3 Supplying the drive with DC / DC bus paralleling

All drives except for size 8 and size 9 may be supplied with DC instead of 3 phase AC.

The connecting of the DC bus between several drives is typically used to:

1. Return energy from a drive which is being overhauled by the load to a second motoring drive.
2. Allow the use of one braking resistor to dissipate regenerative energy from several drives.

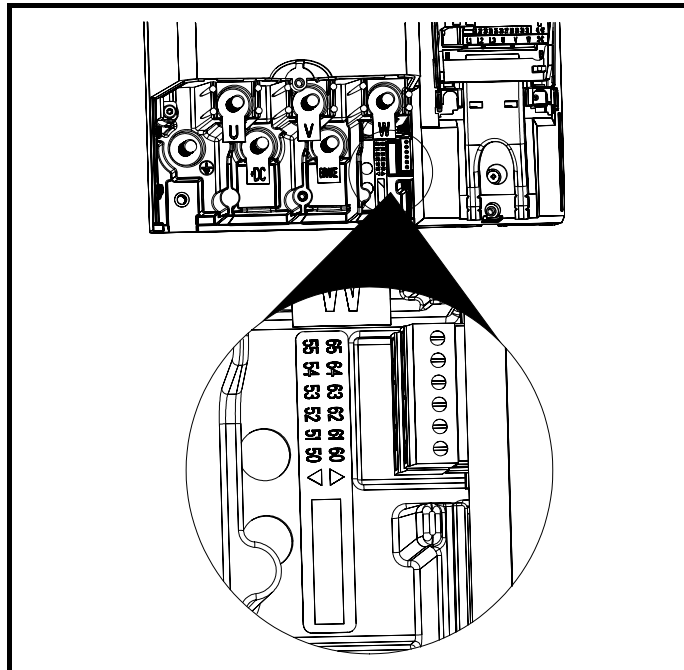
There are limitations to the combinations of drives which can be used in this configuration.

For application data, contact the supplier of the drive.

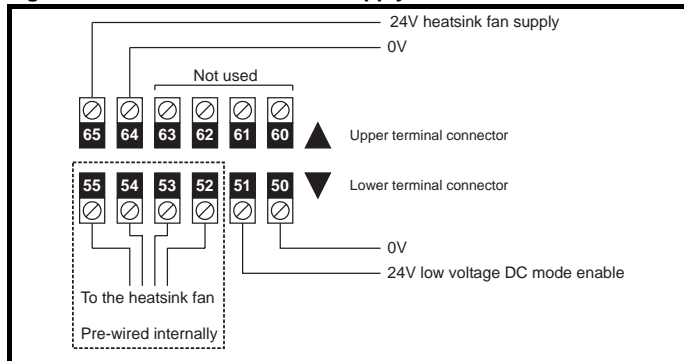
## 4.4 Heatsink fan supply

The heatsink fan on Unidrive SP size 1 to 5 is supplied internally by the drive. The heatsink fan on size 6 requires an external 24Vdc supply. The connections for the heatsink fan supply must be made to the upper terminal connector near to the W phase output on the drive. Figure 4-11 shows the position of the heatsink fan supply connections.

**Figure 4-11 Location of the size 6 heatsink fan supply connections**



**Figure 4-12 Size 6 heatsink fan supply connections**

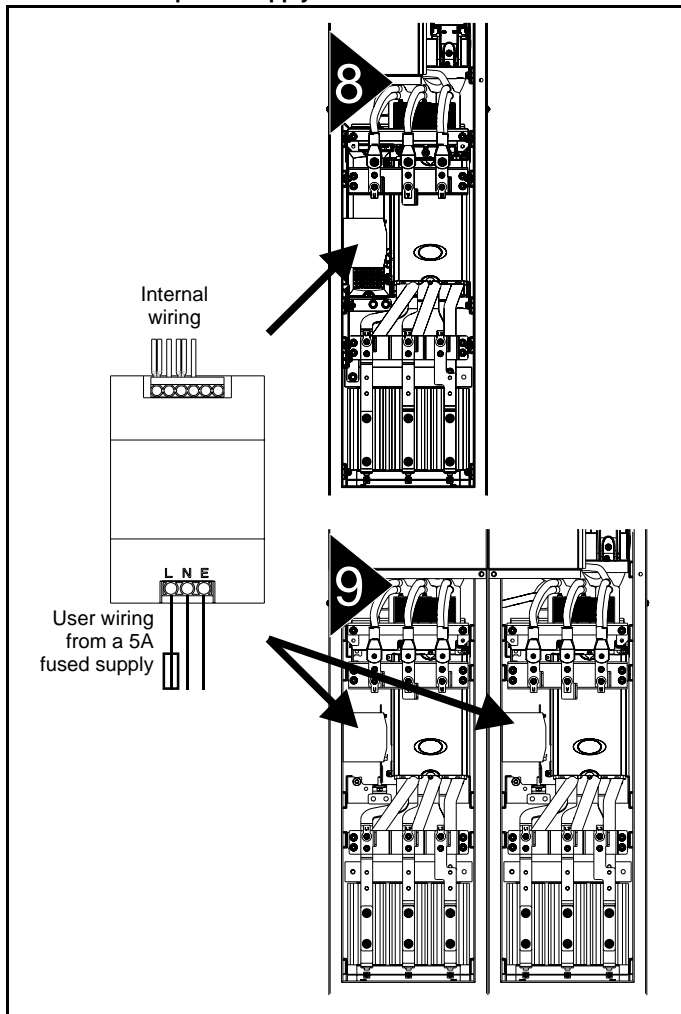


The heatsink fan supply requirements are as follows:

- Nominal voltage: 24Vdc
- Minimum voltage: 23.5Vdc
- Maximum voltage: 27Vdc
- Current drawn: 3.3A
- Recommended power supply: 24V, 100W, 4.5A
- Recommended fuse: 4A fast blow ( $I^2t$  less than  $20A^2s$ )

The 24V power supply is supplied in the free standing cubicle but requires a user 115V or 240V supply.

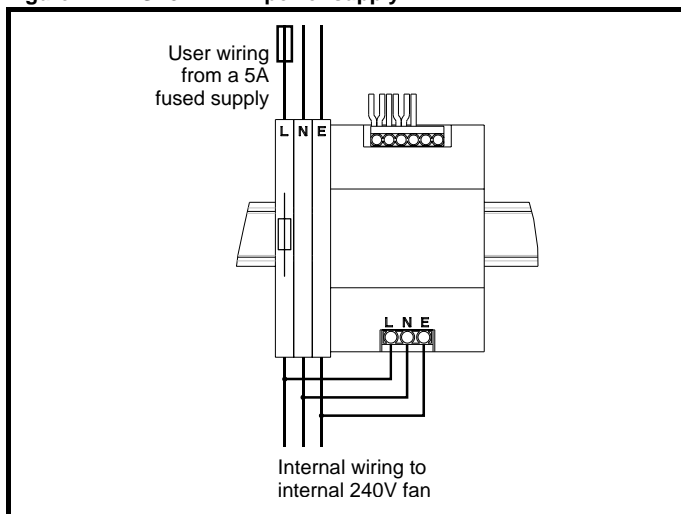
**Figure 4-13 Location of size 8 and 9 free standing cubicle drive 24V power supply**



CT part number: 8510-0000  
 Current rating: 10A  
 Input voltage: 85 to 123 / 176 to 264Vac auto switching  
 Cable size: 0.5mm<sup>2</sup> (20AWG)  
 Supply fuse: 5A slow-blow

For the SP8414 model, the design of the 24V power supply is different due to the additional fan on the cubicle roof, as shown in Figure 4-14.

**Figure 4-14 SP8414 24V power supply**



## 4.5 Control 24Vdc supply

The 24Vdc input on the Unidrive SP has three main functions.

- It can be used to supplement the drive's own internal 24V when multiple SM-Universal Encoder Plus, or SM-I/O Plus modules are being used and the current drawn by these modules is greater than the drive can supply. (If too much current is drawn from the drive, the drive will initiate a 'PS.24V' trip)
- It can be used as a back-up power supply to keep the control circuits of the drive powered up when the mains supply is removed. This allows any fieldbus modules, application modules, encoders or serial communications to continue to operate.
- It can be used to commission the drive when mains voltages are not available, as the display operates correctly. However, the drive will be in the UV trip state unless either mains or low voltage DC operation is enabled, therefore diagnostics may not be possible. (Power down save parameters are not saved when using the 24V back-up power supply input.)

The working voltage range of the 24V power supply is as follows:

|  |             |
|--|-------------|
| Maximum continuous operating voltage:    | 30.0 V      |
| Minimum continuous operating voltage:    | 19.2 V      |
| Nominal operating voltage:               | 24.0 V      |
| Minimum start up voltage:                | 21.6 V      |
| Maximum power supply requirement at 24V: | 60 W        |
| Recommended fuse:                        | 3 A, 50 Vdc |

Minimum and maximum voltage values include ripple and noise. Ripple and noise values must not exceed 5%.

## 4.6 Low voltage DC power supply

The Unidrive SP can be operated from low voltage DC supplies, nominally 24Vdc (control) and 48Vdc (power). The low voltage DC power operating mode is designed either, to allow for motor operation in an emergency back-up situation following failure of the AC supply, for example in elevators; or to limit the speed of a servo motor during commissioning of equipment, for example a robot cell.

The working voltage range of the low voltage DC power supply is as follows:

### Size 1

|                                       |       |
|---------------------------------------|-------|
| Minimum continuous operating voltage: | 36V   |
| Minimum start up voltage:             | 40V   |
| Nominal continuous operating voltage: | 48V   |
| Maximum braking IGBT turn on voltage: | 63.6V |
| Maximum over voltage trip threshold:  | 69.6V |

### Size 2 and 3

|                                       |           |
|---------------------------------------|-----------|
| Minimum continuous operating voltage: | 36V       |
| Minimum start up voltage:             | 40V       |
| Nominal continuous operating voltage: | 48 to 72V |
| Maximum braking IGBT turn on voltage: | 95.4V     |
| Maximum over voltage trip threshold:  | 104.4V    |

### Size 4 (200V drives)

|                                       |           |
|---------------------------------------|-----------|
| Minimum continuous operating voltage: | 36V       |
| Nominal continuous operating voltage: | 48 to 72V |
| Maximum braking IGBT turn on voltage: | 95.4V     |
| Maximum over voltage trip threshold:  | 104.4V    |

### Size 4, 5 and 6 (400V and 690V drives)

|                                       |           |
|---------------------------------------|-----------|
| Minimum continuous operating voltage: | 36V       |
| Nominal continuous operating voltage: | 48 to 96V |
| Maximum braking IGBT turn on voltage: | 127.2V    |
| Maximum over voltage trip threshold:  | 139.2V    |

### Size 8 and 9 free standing cubicle drives

Not applicable.

See section 4.5 *Control 24Vdc supply* on page 74 for 24V back-up to control.

### NOTE

The nominal low voltage supply level is set by the user in Pr 6.46.

The default setting is 48V for all drive sizes.

The over voltage trip threshold and braking IGBT turn on voltage are scaled from this value as follows:

$$\text{Brake IGBT turn on} = 1.325 \times \text{Pr } 6.46 \text{ (V)}$$

$$\text{Over voltage trip} = 1.45 \times \text{Pr } 6.46 \text{ (V)}$$

For application data, refer to the *Unidrive SP Low Voltage DC Operation Application Note*.

## 4.7 Ratings

The input current is affected by the supply voltage and impedance.

### Typical input current

The values of typical input current are given to aid calculations for power flow and power loss.

The values of typical input current are stated for a balanced supply.

### Maximum continuous input current

The values of maximum continuous input current are given to aid the selection of cables and fuses. These values are stated for the worst case condition with the unusual combination of stiff supply with bad balance. The value stated for the maximum continuous input current would only be seen in one of the input phases. The current in the other two phases would be significantly lower.

The values of maximum input current are stated for a supply with a 2% negative phase-sequence imbalance and rated at the supply fault current given in Table 4-2.

**Table 4-2 Supply fault current used to calculate maximum input currents**

| Model | Symmetrical fault level (kA) |
|-------|------------------------------|
| All   | 100                          |

**Table 4-3 Size 1 to 3 input current, fuse and cable size ratings (European)**

| Model  | Typical input current A | Maximum continuous input current A | Fuse rating IEC gG A | Cable size EN60204    |                        |
|--------|-------------------------|------------------------------------|----------------------|-----------------------|------------------------|
|        |                         |                                    |                      | Input mm <sup>2</sup> | Output mm <sup>2</sup> |
| SP1201 | 7.1                     | 9.5                                | 10                   | 1.5                   | 1.0                    |
| SP1202 | 9.2                     | 11.3                               | 12                   | 1.5                   | 1.0                    |
| SP1203 | 12.5                    | 16.4                               | 20                   | 4.0                   | 1.0                    |
| SP1204 | 15.4                    | 19.1                               | 20                   | 4.0                   | 1.5                    |
| SP2201 | 13.4                    | 18.1                               | 20                   | 4.0                   | 2.5                    |
| SP2202 | 18.2                    | 22.6                               | 25                   | 4.0                   | 4.0                    |
| SP2203 | 24.2                    | 28.3                               | 32                   | 6.0                   | 6.0                    |
| SP3201 | 35.4                    | 43.1                               | 50                   | 16                    | 16                     |
| SP3202 | 46.8                    | 54.3                               | 63                   | 25                    | 25                     |
| SP1401 | 4.1                     | 4.8                                | 8                    | 1.0                   | 1.0                    |
| SP1402 | 5.1                     | 5.8                                | 8                    | 1.0                   | 1.0                    |
| SP1403 | 6.8                     | 7.4                                | 8                    | 1.0                   | 1.0                    |
| SP1404 | 9.3                     | 10.6                               | 12                   | 1.5                   | 1.0                    |
| SP1405 | 10                      | 11                                 | 12                   | 1.5                   | 1.0                    |
| SP1406 | 12.6                    | 13.4                               | 16                   | 2.5                   | 1.5                    |
| SP2401 | 15.7                    | 17                                 | 20                   | 4.0                   | 2.5                    |
| SP2402 | 20.2                    | 21.4                               | 25                   | 4.0                   | 4.0                    |
| SP2403 | 26.6                    | 27.6                               | 32                   | 6.0                   | 6.0                    |
| SP2404 | 26.6                    | 27.6                               | 32                   | 6.0                   | 6.0                    |
| SP3401 | 34.2                    | 36.2                               | 40                   | 10                    | 10                     |
| SP3402 | 40.2                    | 42.7                               | 50                   | 16                    | 16                     |
| SP3403 | 51.3                    | 53.5                               | 63                   | 25                    | 25                     |
| SP3501 | 5.0                     | 6.7                                | 8                    | 1.0                   | 1.0                    |
| SP3502 | 6.0                     | 8.2                                | 10                   | 1.0                   | 1.0                    |
| SP3503 | 7.8                     | 11.1                               | 12                   | 1.5                   | 1.0                    |
| SP3504 | 9.9                     | 14.4                               | 16                   | 2.5                   | 1.5                    |
| SP3505 | 13.8                    | 18.1                               | 20                   | 4.0                   | 2.5                    |
| SP3506 | 18.2                    | 22.2                               | 25                   | 4.0                   | 4.0                    |
| SP3507 | 22.2                    | 26.0                               | 32                   | 6.0                   | 6.0                    |

**Table 4-4 Size 1 to 3 input current, fuse and cable size ratings (USA)**

| Model  | Typical input current A | Maximum continuous input current A | Fuse rating Class CC <30A Class J >30A A | Cable size UL508C |            |
|--------|-------------------------|------------------------------------|--|-------------------|------------|
|        |                         |                                    |  | Input AWG         | Output AWG |
| SP1201 | 7.1                     | 9.5                                | 10                                       | 14                | 18         |
| SP1202 | 9.2                     | 11.3                               | 15                                       | 14                | 16         |
| SP1203 | 12.5                    | 16.4                               | 20                                       | 12                | 14         |
| SP1204 | 15.4                    | 19.1                               | 20                                       | 12                | 14         |
| SP2201 | 13.4                    | 18.1                               | 20                                       | 12                | 14         |
| SP2202 | 18.2                    | 22.6                               | 25                                       | 10                | 10         |
| SP2203 | 24.2                    | 28.3                               | 30                                       | 8                 | 8          |
| SP3201 | 35.4                    | 43.1                               | 45                                       | 6                 | 6          |
| SP3202 | 46.8                    | 54.3                               | 60                                       | 4                 | 4          |
| SP1401 | 4.1                     | 4.8                                | 8  | 16                | 22         |
| SP1402 | 5.1                     | 5.8                                | 8  | 16                | 20         |
| SP1403 | 6.8                     | 7.4                                | 10                                       | 16                | 18         |
| SP1404 | 9.3                     | 10.6                               | 15                                       | 14                | 16         |
| SP1405 | 10                      | 11                                 | 15                                       | 14                | 14         |
| SP1406 | 12.6                    | 13.4                               | 15                                       | 14                | 14         |
| SP2401 | 15.7                    | 17                                 | 20                                       | 12                | 14         |
| SP2402 | 20.2                    | 21.4                               | 25                                       | 10                | 10         |
| SP2403 | 26.6                    | 27.6                               | 30                                       | 8                 | 8          |
| SP2404 | 26.6                    | 27.6                               | 30                                       | 8                 | 8          |
| SP3401 | 34.2                    | 36.2                               | 40                                       | 6                 | 6          |
| SP3402 | 40.2                    | 42.7                               | 45                                       | 6                 | 6          |
| SP3403 | 51.3                    | 53.5                               | 60                                       | 4                 | 4          |
| SP3501 | 5.0                     | 6.7                                | 10                                       | 16                | 18         |
| SP3502 | 6.0                     | 8.2                                | 10                                       | 16                | 16         |
| SP3503 | 7.8                     | 11.1                               | 15                                       | 14                | 14         |
| SP3504 | 9.9                     | 14.4                               | 15                                       | 14                | 14         |
| SP3505 | 13.8                    | 18.1                               | 20                                       | 12                | 14         |
| SP3506 | 18.2                    | 22.2                               | 25                                       | 10                | 10         |
| SP3507 | 22.2                    | 26.0                               | 30                                       | 8                 | 8          |

**Table 4-5 Size 4 and larger input current, fuse and cable size ratings**

| Model  | Typical input current | Maximum input current | Fuse option 1 |                              | Fuse option 2<br>semiconductor fuse in series<br>with HRC fuse or breaker |                                | Cable size |         |                 |         |
|--------|-----------------------|-----------------------|---------------|------------------------------|---|--------------------------------|------------|---------|-----------------|---------|
|        |                       |                       | IEC class gR  | North America:<br>Ferraz HSJ | HRC<br>IEC class gG<br>UL class J   | Semi-conductor<br>IEC class aR | Input      |         | Output          |         |
|        |                       |                       | A             | A                            | A   | A                              | A          | A       | mm <sup>2</sup> | AWG     |
| SP4201 | 62.1                  | 68.9                  | 100           | 90                           | 90  | 160                            | 25         | 3       | 25              | 3       |
| SP4202 | 72.1                  | 78.1                  | 100           | 100                          | 100   | 160                            | 35         | 3       | 35              | 3       |
| SP4203 | 94.5                  | 99.9                  | 125           | 125                          | 125   | 200                            | 70         | 1       | 70              | 1       |
| SP4401 | 61.2                  | 62.3                  | 80            | 80                           | 80  | 160                            | 25         | 3       | 25              | 3       |
| SP4402 | 76.3                  | 79.6                  | 110           | 110                          | 100   | 200                            | 35         | 2       | 35              | 2       |
| SP4403 | 94.1                  | 97.2                  | 125           | 125                          | 125   | 200                            | 70         | 1       | 70              | 1       |
| SP5401 | 126                   | 131                   | 200           | 175                          | 160   | 200                            | 95         | 2/0     | 95              | 2/0     |
| SP5402 | 152                   | 156                   | 250           | 225                          | 200   | 250                            | 120        | 4/0     | 120             | 4/0     |
| SP6401 | 206                   | 215                   | 250           | 250                          | 250   | 315                            | 2 x 70     | 2 x 2/0 | 2 x 70          | 2 x 2/0 |
| SP6402 | 247                   | 258                   | 315           | 300                          | 300   | 350                            | 2 x 120    | 2 x 4/0 | 2 x 120         | 2 x 4/0 |
| SP8411 | 377                   | 418                   |               |                              | 500   | 400                            | 2 x 120    | 2 x 410 | 2 x 120         | 2 x 410 |
| SP8412 | 432                   | 479                   |               |                              | 500   | 800                            | 2 x 120    | 2 x 500 | 2 x 120         | 2 x 500 |
| SP8413 | 535                   | 593                   |               |                              | 600   | 800                            | 2 x 185    | 3 x 400 | 2 x 185         | 3 x 400 |
| SP8414 | 631                   | 700                   |               |                              | 700   | 800                            | 2 x 240    | 4 x 350 | 2 x 240         | 4 x 350 |
| SP4601 | 23                    | 26.5                  | 63            | 60                           | 32  | 125                            | 4          | 10      | 4               | 10      |
| SP4602 | 26.1                  | 28.8                  | 63            | 60                           | 40  | 125                            | 6          | 8       | 6               | 8       |
| SP4603 | 32.9                  | 35.1                  | 63            | 60                           | 50  | 125                            | 10         | 8       | 10              | 8       |
| SP4604 | 39                    | 41                    | 63            | 60                           | 50  | 125                            | 16         | 6       | 16              | 6       |
| SP4605 | 46.2                  | 47.9                  | 63            | 60                           | 63  | 125                            | 16         | 6       | 16              | 6       |
| SP4606 | 55.2                  | 56.9                  | 80            | 60                           | 63  | 125                            | 25         | 4       | 25              | 4       |
| SP5601 | 75.5                  | 82.6                  | 125           | 100                          | 90  | 160                            | 35         | 2       | 35              | 2       |
| SP5602 | 89.1                  | 94.8                  | 125           | 100                          | 125   | 160                            | 50         | 1       | 50              | 1       |
| SP6601 | 128                   | 139                   | 160           | 175                          | 150   | 315                            | 2 x 50     | 2 x 1   | 2 x 50          | 2 x 1   |
| SP6602 | 144                   | 155                   | 160           | 175                          | 160   | 315                            | 2 x 50     | 2 x 1   | 2 x 50          | 2 x 1   |

The Semiconductor IEC class aR fuses for size 8 and 9 drives must be fitted within the cubicle, see Figure 3-20 on page 36. These parts may be bought from Control Techniques, see Table 4-6.

**Table 4-6 Size 8 and 9 fuses**

| Fuse IEC aR | Part No.  |
|-------------|-----------|
| 800A        | 4300-0800 |
| 400A        | 4300-0400 |

**Installation class (ref: IEC60364-5-52:2001)**

- B1 - Separate cables in conduit.
- B2 - Multicore cable in conduit
- C - Multicore cable in free air.

**NOTE**

Cable sizes are from IEC60364-5-52:2001 table A.52.C with correction factor for 40°C ambient of 0.87 (from table A52.14) for cable installation method B2 (multicore cable in conduit).

Cable size may be reduced if a different installation method is used, or if the ambient temperature is lower.

The recommended cable sizes above are only a guide. The mounting and grouping of cables affects their current-carrying capacity, in some cases smaller cables may be acceptable but in other cases a larger cable is required to avoid excessive temperature or voltage drop. Refer to local wiring regulations for the correct size of cables.


**NOTE**

The recommended output cable sizes assume that the motor maximum current matches that of the drive. Where a motor of reduced rating is used the cable rating may be chosen to match that of the motor. To ensure that the motor and cable are protected against overload, the drive must be programmed with the correct motor rated current.

**NOTE**

UL listing is dependent on the use of the correct type of UL-listed fuse, and applies when symmetrical short-circuit current does not exceed 5kA for sizes 1 to 3. See Chapter 14 *UL Listing Information* on page 292 for sizing information.

**Fuses**

 The AC supply to the drive must be fitted with suitable protection against overload and short-circuits. Table 4-3, Table 4-4 and Table 4-5 show recommended fuse ratings.

**WARNING** Failure to observe this requirement will cause risk of fire.

A fuse or other protection must be included in all live connections to the AC supply.

An MCB (miniature circuit breaker) or MCCB (moulded-case circuit-breaker) with type C may be used in place of fuses on Unidrive SP sizes 1 to 3 under the following conditions:

- The fault-clearing capacity must be sufficient for the installation
- For frame sizes 2 and 3, the drive must be mounted in an enclosure which meets the requirements for a fire enclosure

See Chapter 14 *UL Listing Information* for UL listing requirements.

## Fuse types

The fuse voltage rating must be suitable for the drive supply voltage.

## Ground connections

The drive must be connected to the system ground of the AC supply. The ground wiring must conform to local regulations and codes of practice.


### 4.7.1 Main AC supply contactor

The recommended AC supply contactor type for sizes 1 to 6 is AC1.

## 4.8 Output circuit and motor protection

The output circuit has fast-acting electronic short-circuit protection which limits the fault current to typically no more than five times the rated output current, and interrupts the current in approximately 20µs. No additional short-circuit protection devices are required.

The drive provides overload protection for the motor and its cable. For this to be effective, Pr 0.46 *Motor rated current* must be set to suit the motor.



**Pr 0.46** *Motor rated current* must be set correctly to avoid a risk of fire in the event of motor overload.

**WARNING**

There is also provision for the use of a motor thermistor to prevent overheating of the motor, e.g. due to loss of cooling.

### 4.8.1 Cable types and lengths

Since capacitance in the motor cable causes loading on the output of the drive, ensure the cable length does not exceed the values given in Table 4-7, Table 4-8 and Table 4-9.

Use 105°C (221°F) (UL 60/75°C temp rise) PVC-insulated cable with copper conductors having a suitable voltage rating, for the following power connections:

- AC supply to external EMC filter (when used)
- AC supply (or external EMC filter) to drive
- Drive to motor
- Drive to braking resistor

**Table 4-7 Maximum motor cable lengths (200V drives)**

| 200V Nominal AC supply voltage |  |                 |                 |                |                |                |
|--------------------------------|--|-----------------|-----------------|----------------|----------------|----------------|
| Model                          | Maximum permissible motor cable length for each of the following frequencies |                 |                 |                |                |                |
|                                | 3kHz   | 4kHz            | 6kHz            | 8kHz           | 12kHz          | 16kHz          |
| SP1201                         | 65m (210ft)  |                 |                 |                |                |                |
| SP1202                         | 100m (330ft)   |                 |                 |                |                |                |
| SP1203                         | 130m (425ft)   |                 |                 |                |                |                |
| SP1204                         | 200m<br>(660ft)  | 150m<br>(490ft) | 100m<br>(330ft) | 75m<br>(245ft) | 50m<br>(165ft) | 37m<br>(120ft) |
| SP2201                         |  |                 |                 |                |                |                |
| SP2202                         |  |                 |                 |                |                |                |
| SP2203                         |  |                 |                 |                |                |                |
| SP3201                         |  |                 |                 |                |                |                |
| SP3202                         |  |                 |                 |                |                |                |
| SP4201                         | 250m<br>(820ft)  | 185m<br>(607ft) | 125m<br>(410ft) | 90m<br>(295ft) |                |                |
| SP4202                         |  |                 |                 |                |                |                |
| SP4203                         |  |                 |                 |                |                |                |

**Table 4-8 Maximum motor cable lengths (400V drives)**

| 400V Nominal AC supply voltage |  |                  |                 |                |                |                |
|--------------------------------|--|------------------|-----------------|----------------|----------------|----------------|
| Model                          | Maximum permissible motor cable length for each of the following frequencies |                  |                 |                |                |                |
|                                | 3kHz   | 4kHz             | 6kHz            | 8kHz           | 12kHz          | 16kHz          |
| SP1401                         | 65m (210ft)  |                  |                 |                |                |                |
| SP1402                         | 100m (330ft)   |                  |                 |                |                |                |
| SP1403                         | 130m (425ft)   |                  |                 |                |                |                |
| SP1404                         | 200m<br>(660ft)  | 150m<br>(490ft)  | 100m<br>(330ft) | 75m<br>(245ft) | 50m<br>(165ft) | 37m<br>(120ft) |
| SP1405                         |  |                  |                 |                |                |                |
| SP1406                         |  |                  |                 |                |                |                |
| SP2401                         |  |                  |                 |                |                |                |
| SP2402                         |  |                  |                 |                |                |                |
| SP2403                         |  |                  |                 |                |                |                |
| SP2404                         |  |                  |                 |                |                |                |
| SP3401                         |  |                  |                 |                |                |                |
| SP3402                         |  |                  |                 |                |                |                |
| SP3403                         |  |                  |                 |                |                |                |
| SP4401                         | 250m<br>(820ft)  | 185m<br>(607ft)  | 125m<br>(410ft) | 90m<br>(295ft) |                |                |
| SP4402                         |  |                  |                 |                |                |                |
| SP4403                         |  |                  |                 |                |                |                |
| SP5401                         |  |                  |                 |                |                |                |
| SP5402                         |  |                  |                 |                |                |                |
| SP6401                         |  |                  |                 |                |                |                |
| SP6402                         |  |                  |                 |                |                |                |
| SP8411                         | 500m<br>(1640ft)   | 370m<br>(1214ft) | 250m<br>(820ft) |                |                |                |
| SP8412                         |  |                  |                 |                |                |                |
| SP8413                         |  |                  |                 |                |                |                |
| SP8414                         |  |                  |                 |                |                |                |
| SP9411                         |  |                  |                 |                |                |                |
| SP9412                         |  |                  |                 |                |                |                |
| SP9413                         |  |                  |                 |                |                |                |
| SP9414                         |  |                  |                 |                |                |                |
| SP9415                         |  |                  |                 |                |                |                |

**Table 4-9 Maximum motor cable lengths (575V drives)**

| 575V Nominal AC supply voltage |  |                 |                 |                |       |       |
|--------------------------------|--|-----------------|-----------------|----------------|-------|-------|
| Model                          | Maximum permissible motor cable length for each of the following frequencies |                 |                 |                |       |       |
|                                | 3kHz   | 4kHz            | 6kHz            | 8kHz           | 12kHz | 16kHz |
| SP3501                         | 200m<br>(660ft)  | 150m<br>(490ft) | 100m<br>(330ft) | 75m<br>(245ft) |       |       |
| SP3502                         |  |                 |                 |                |       |       |
| SP3503                         |  |                 |                 |                |       |       |
| SP3504                         |  |                 |                 |                |       |       |
| SP3505                         |  |                 |                 |                |       |       |
| SP3506                         |  |                 |                 |                |       |       |
| SP3507                         |  |                 |                 |                |       |       |

**Table 4-10 Maximum motor cable lengths (690V drives)**

| 690V Nominal AC supply voltage |  |                 |                 |                |       |       |
|--------------------------------|--|-----------------|-----------------|----------------|-------|-------|
| Model                          | Maximum permissible motor cable length for each of the following frequencies |                 |                 |                |       |       |
|                                | 3kHz   | 4kHz            | 6kHz            | 8kHz           | 12kHz | 16kHz |
| SP4601                         | 250m<br>(820ft)  | 185m<br>(607ft) | 125m<br>(410ft) | 90m<br>(295ft) |       |       |
| SP4602                         |  |                 |                 |                |       |       |
| SP4603                         |  |                 |                 |                |       |       |
| SP4604                         |  |                 |                 |                |       |       |
| SP4605                         |  |                 |                 |                |       |       |
| SP4606                         |  |                 |                 |                |       |       |
| SP5601                         |  |                 |                 |                |       |       |
| SP5602                         |  |                 |                 |                |       |       |
| SP6601                         |  |                 |                 |                |       |       |
| SP6602                         |  |                 |                 |                |       |       |

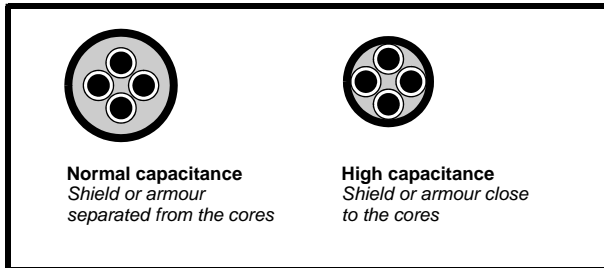
- Cable lengths in excess of the specified values may be used only when special techniques are adopted; refer to the supplier of the drive.
- The default switching frequency is 3kHz for open-loop and closed-loop vector and 6kHz for servo.

**High-capacitance cables**

The maximum cable length is reduced from that shown in Table 4-7, Table 4-8, Table 4-9 and Table 4-10 if high capacitance motor cables are used.

Most cables have an insulating jacket between the cores and the armour or shield; these cables have a low capacitance and are recommended. Cables that do not have an insulating jacket tend to have high capacitance; if a cable of this type is used, the maximum cable length is half that quoted in the tables. (Figure 4-15 shows how to identify the two types.)

**Figure 4-15 Cable construction influencing the capacitance**



The cable used for Table 4-7, Table 4-8, Table 4-9 and Table 4-10 is shielded and contains four cores. Typical capacitance for this type of cable is 130pF/m (i.e. from one core to all others and the shield connected together).

**4.8.2 Motor winding voltage**

The PWM output voltage can adversely affect the inter-turn insulation in the motor. This is because of the high rate of change of voltage, in conjunction with the impedance of the motor cable and the distributed nature of the motor winding.

For normal operation with AC supplies up to 500Vac and a standard motor with a good quality insulation system, there is no need for any special precautions. In case of doubt the motor supplier should be consulted.

Special precautions are recommended under the following conditions, but only if the motor cable length exceeds 10m:

- AC supply voltage exceeds 500V
- DC supply voltage exceeds 670V
- Operation of 400V drive with continuous or very frequent sustained braking
- Multiple motors connected to a single drive

For multiple motors, the precautions given in section 4.8.3 *Multiple motors* should be followed.

For the other cases listed, it is recommended that an inverter-rated motor be used. This has a reinforced insulation system intended by the manufacturer for repetitive fast-rising pulsed voltage operation.

Users of 575V NEMA rated motors should note that the specification for inverter-rated motors given in NEMA MG1 section 31 is sufficient for motoring operation but not where the motor spends significant periods braking. In that case an insulation peak voltage rating of 2.2kV is recommended.

If it is not practical to use an inverter-rated motor, an output choke (inductor) should be used. The recommended type is a simple iron-cored component with a reactance of about 2%. The exact value is not critical. This operates in conjunction with the capacitance of the motor cable to increase the rise-time of the motor terminal voltage and prevent excessive electrical stress.

**4.8.3 Multiple motors**

**Open-loop only**

If the drive is to control more than one motor, one of the fixed V/F modes should be selected (Pr 5.14 = Fd or SrE). Make the motor connections as shown in Figure 4-16 and Figure 4-17. The maximum cable lengths in Table 4-7, Table 4-8, Table 4-9 and Table 4-10 apply to the sum of the total cable lengths from the drive to each motor.

It is recommended that each motor is connected through a protection relay since the drive cannot protect each motor individually. For star connection, a sinusoidal filter or an output inductor must be connected as shown in Figure 4-17, even when the cable lengths are less than the maximum permissible. For details of inductor sizes refer to the supplier of the drive.

**Figure 4-16 Preferred chain connection for multiple motors**

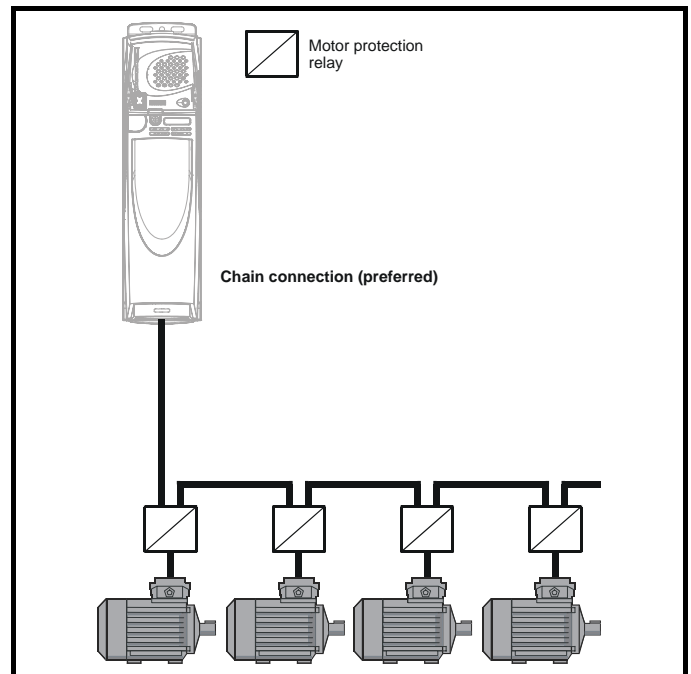
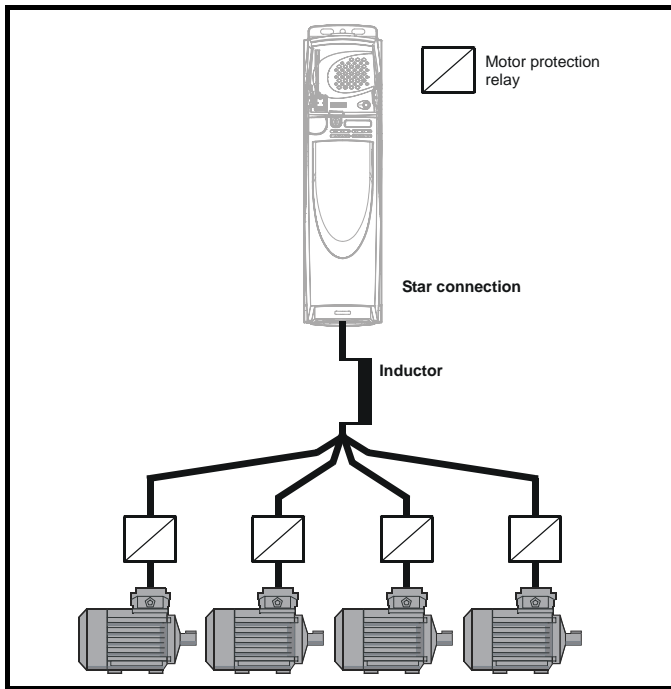


Figure 4-17 Alternative connection for multiple motors



#### 4.8.4 Star / delta motor operation

The voltage rating for star and delta connections of the motor should always be checked before attempting to run the motor.

The default setting of the motor rated voltage parameter is the same as the drive rated voltage, i.e.

- 400V drive 400V rated voltage
- 200V drive 200V rated voltage

A typical 3 phase motor would be connected in star for 400V operation or delta for 200V operation, however, variations on this are common e.g. star 690V delta 400V

Incorrect connection of the windings will cause severe under or over fluxing of the motor, leading to a very poor output torque or motor saturation and overheating respectively.

#### 4.8.5 Output contactor

If the cable between the drive and the motor is to be interrupted by a contactor or circuit breaker, ensure that the drive is disabled before the contactor or circuit breaker is opened or closed. Severe arcing may occur if this circuit is interrupted with the motor running at high current and low speed.

**WARNING**

A contactor is sometimes required to be fitted between the drive and motor for safety purposes.

The recommended motor contactor is the AC3 type.

Switching of an output contactor should only occur when the output of the drive is disabled.

Opening or closing of the contactor with the drive enabled will lead to:

1. OI.AC trips (which cannot be reset for 10 seconds)
2. High levels of radio frequency noise emission
3. Increased contactor wear and tear

The Drive Enable terminal (T31) when opened provides a SECURE DISABLE function. This can in many cases replace output contactors.

For further information see section 4.16 SECURE DISABLE on page 100.

## 4.9 Braking

Braking occurs when the drive is decelerating the motor, or is preventing the motor from gaining speed due to mechanical influences. During braking, energy is returned to the drive from the motor.

When the motor is being braked by the drive, the maximum regenerated power that the drive can absorb is equal to the power dissipation (losses) of the drive.

When the regenerated power is likely to exceed these losses, the DC bus voltage of the drive increases. Under default conditions, the drive brakes the motor under PI control, which extends the deceleration time as necessary in order to prevent the DC bus voltage from rising above a user defined set-point.

If the drive is expected to rapidly decelerate a load, or to hold back an overhauling load, a braking resistor must be fitted. Note size 8 and 9 drives cannot operate a braking resistor.

Table 4-11 shows the DC voltage level at which the drive turns on the braking transistor.

Table 4-11 Braking transistor turn on voltage

| Drive voltage rating | DC bus voltage level |
|----------------------|----------------------|
| 200V                 | 390V                 |
| 400V                 | 780V                 |
| 575V                 | 930V                 |
| 690V                 | 1120V                |

#### NOTE

When a braking resistor is used, Pr 0.15 should be set to FAST ramp mode.

**High temperatures**  
Braking resistors can reach high temperatures. Locate braking resistors so that damage cannot result. Use cable having insulation capable of withstanding high temperatures.

**WARNING**

#### 4.9.1 Heatsink mounted braking resistor

A resistor has been especially designed to be mounted within the heatsink of the Unidrive SP (sizes 1 and 2). See section 3.13 *Heatsink mounted braking resistor* on page 60 for mounting details. The design of the resistor is such that no thermal protection circuit is required, as the device will fail safely under fault conditions. On Unidrive SP sizes 1 and 2, the in built software overload protection is set up at default for the designated heatsink mounted resistor. Table 4-12 provides the resistor data for each drive rating.

#### NOTE

The heatsink mounted resistor is suitable for applications with a low level of regen energy only. See power rating below.



### Braking resistor overload protection parameter settings

**Failure to observe the following information may damage the resistor.**

**CAUTION**

The Unidrive SP software contains an overload protection function for a braking resistor. On Unidrive SP size 1 and 2 this function is enabled at default to protect the heatsink mounted resistor. Below are the parameter settings.

| Parameter                 |          | 200V drive | 400V drive |
|---------------------------|----------|------------|------------|
| Full power braking time   | Pr 10.30 | 0.09       | 0.02       |
| Full power braking period | Pr 10.31 | 2.0        |            |

For more information on the braking resistor software overload protection, see Pr 10.30 and Pr 10.31 full descriptions in the *Unidrive SP Advanced User Guide*.

If the heatsink mounted braking resistor is to be used at more than half of its average power rating then the drive's cooling fan must be at full speed controlled by setting Pr 6.45 to On (1).

**Table 4-12 Heatsink mounted braking resistor data**

| Parameter   | Size 1       | Size 2       |
|---|--------------|--------------|
| Part number   | 1220-2756-01 | 1220-2758-01 |
| DC resistance at 25°C                                   | 75Ω          | 37.5Ω        |
| Peak instantaneous power over 1ms at nominal resistance | 8kW          | 16kW         |
| Average power over 60s *                                | 50W          | 100W         |
| Ingress Protection (IP) rating                          | IP54         |              |
| Maximum altitude  | 2000m        |              |

\* To keep the temperature of the resistor below 70°C (158°F) in a 30°C (86°F) ambient, the average power rating is 50W for size 1 and 100W for size 2. The above parameter settings ensure this is the case.

Unidrive SP size 3 and larger do not have heatsink mounted braking resistors, hence the default values of Pr 10.30 and Pr 10.31 are 0 (i.e. software braking resistor overload protection disabled).

### 4.9.2 External braking resistor



#### Overload protection

When an external braking resistor is used, it is essential that an overload protection device is incorporated in the braking resistor circuit; this is described in Figure 4-18 on page 82.

**WARNING**

When a braking resistor is to be mounted outside the enclosure, ensure that it is mounted in a ventilated metal housing that will perform the following functions:

- Prevent inadvertent contact with the resistor
- Allow adequate ventilation for the resistor

When compliance with EMC emission standards is required, external connection requires the cable to be armoured or shielded, since it is not fully contained in a metal enclosure. See section 4.11.5 *Compliance with generic emission standards* on page 88 for further details.

Internal connection does not require the cable to be armoured or shielded.

### Minimum resistances and power ratings

**Table 4-13 Minimum resistance values and peak power rating for the braking resistor at 40°C (104°F)**

| Model    | Minimum resistance*<br>Ω | Instantaneous power rating<br>kW | Average power for 60s<br>kW |
|----------|--------------------------|----------------------------------|-----------------------------|
| SP1201   | 43                       | 3.5                              | 1.5                         |
| SP1202   |                          |                                  | 2.2                         |
| SP1203   |                          |                                  | 3.0                         |
| SP1204   | 29                       | 5.3                              | 4.4                         |
| SP2201   | 18                       | 8.9                              | 6.0                         |
| SP2202   |                          |                                  | 8.0                         |
| SP2203   |                          |                                  | 8.9                         |
| SP3201   | 5.0                      | 30.3                             | 13.1                        |
| SP3202   |                          |                                  | 19.3                        |
| SP4201** | 5.0                      | 30.3                             | 22.5                        |
| SP4202** |                          |                                  | 27.8                        |
| SP4203** |                          |                                  | 30.3                        |
| SP1401   | 74                       | 8.3                              | 1.5                         |
| SP1402   |                          |                                  | 2.2                         |
| SP1403   |                          |                                  | 3.0                         |
| SP1404   |                          |                                  | 4.4                         |
| SP1405   |                          |                                  | 6.0                         |
| SP1406   |                          |                                  | 8.0                         |
| SP2401   | 19                       | 33.1                             | 9.6                         |
| SP2402   |                          |                                  | 13.1                        |
| SP2403   |                          |                                  | 19.3                        |
| SP2404   |                          |                                  | 22.5                        |
| SP3401   | 18                       | 35.5                             | 22.5                        |
| SP3402   |                          |                                  | 27.8                        |
| SP3403   |                          |                                  | 33.0                        |
| SP4401** | 11                       | 55.3                             | 45.0                        |
| SP4402** |                          |                                  | 53.0                        |
| SP4403** |                          |                                  | 67.5                        |
| SP5401** | 7                        | 86.9                             | 82.5                        |
| SP5402** |                          |                                  | 86.9                        |
| SP6401   | 5                        | 121.7                            | 90                          |
| SP6402   |                          |                                  | 110                         |
| SP3501   | 18                       | 50.7                             | 4.4                         |
| SP3502   |                          |                                  | 6.0                         |
| SP3503   |                          |                                  | 8.0                         |
| SP3504   |                          |                                  | 9.6                         |
| SP3505   |                          |                                  | 13.1                        |
| SP3506   |                          |                                  | 19.3                        |
| SP3507   |                          |                                  | 22.5                        |
| SP4601** |                          |                                  | 13                          |
| SP4602** | 22.5                     |                                  |                             |
| SP4603** | 27.8                     |                                  |                             |
| SP4604** | 33.0                     |                                  |                             |
| SP4605** | 45.0                     |                                  |                             |
| SP4606** | 55.5                     |                                  |                             |
| SP5601** | 10                       | 125.4                            | 67.5                        |
| SP5602** |                          |                                  | 82.5                        |
| SP6601   |                          |                                  |                             |
| SP6602   |                          |                                  |                             |

\* Resistor tolerance: ±10%

\*\* The minimum resistance value specified is for a stand-alone drive only. If the drive is part of a common DC bus system a different value must be used. Contact the supplier of the drive for more information.

For high-inertia loads or under continuous braking, the *continuous power* dissipated in the braking resistor may be as high as the power rating of

the drive. The total energy dissipated in the braking resistor is dependent on the amount of energy to be extracted from the load.

The instantaneous power rating refers to the short-term maximum power dissipated during the on intervals of the pulse width modulated braking control cycle. The braking resistor must be able to withstand this dissipation for short intervals (milliseconds). Higher resistance values require proportionately lower instantaneous power ratings.

In most applications, braking occurs only occasionally. This allows the continuous power rating of the braking resistor to be much lower than the power rating of the drive. It is essential, though, that the instantaneous power rating and energy rating of the braking resistor are sufficient for the most extreme braking duty that is likely to be encountered.

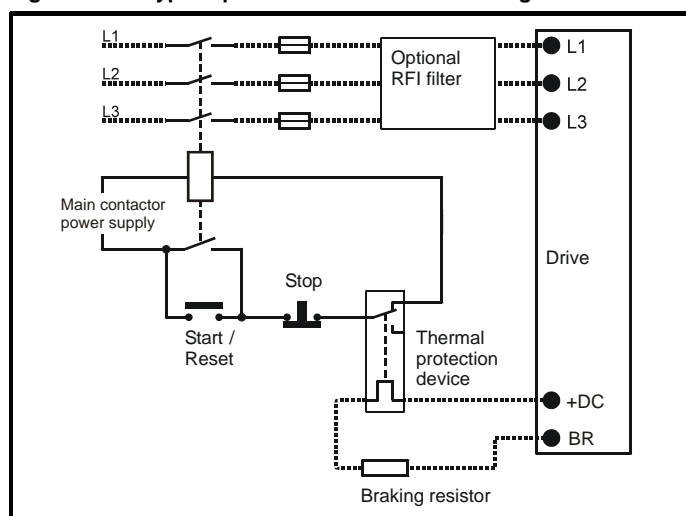
Optimisation of the braking resistor requires a careful consideration of the braking duty.

Select a value of resistance for the braking resistor that is not less than the specified minimum resistance. Larger resistance values may give a cost saving, as well as a safety benefit in the event of a fault in the braking system. Braking capability will then be reduced, which could cause the drive to trip during braking if the value chosen is too large.

### Thermal protection circuit for the braking resistor

The thermal protection circuit must disconnect the AC supply from the drive if the resistor becomes overloaded due to a fault. Figure 4-18 shows a typical circuit arrangement.

**Figure 4-18 Typical protection circuit for a braking resistor**



See Figure 4-1 on page 66, Figure 4-2 and Figure 4-3 on page 67, and Figure 4-4 on page 68 for the location of the +DC and braking resistor connections.

### 4.9.3 Braking resistor software overload protection

The Unidrive SP software contains an overload protection function for a braking resistor. In order to enable and set-up this function, it is necessary to enter two values into the drive:

- Resistor short-time overload time (Pr 10.30)
- Resistor minimum time between repeated short-time overloads (Pr 10.31)

This data should be obtained from the manufacturer of the braking resistors.

Pr 10.39 gives an indication of braking resistor temperature based on a simple thermal model. Zero indicates the resistor is close to ambient and 100% is the maximum temperature the resistor can withstand. An OVLd alarm is given if this parameter is above 75% and the braking IGBT is active. An It.br trip will occur if Pr 10.39 reaches 100%, when Pr 10.37 is set to 0 (default value) or 1.

If Pr 10.37 is equal to 2 or 3 an It.br trip will not occur when Pr 10.39 reaches 100%, but instead the braking IGBT will be disabled until Pr 10.39 falls below 95%. This option is intended for applications with

parallel connected DC buses where there are several braking resistors, each of which cannot withstand full DC bus voltage continuously. With this type of application it is unlikely the braking energy will be shared equally between the resistors because of voltage measurement tolerances within the individual drives. Therefore with Pr 10.37 set to 2 or 3, then as soon as a resistor has reached its maximum temperature the drive will disable the braking IGBT, and another resistor on another drive will take up the braking energy. Once Pr 10.39 has fallen below 95% the drive will allow the braking IGBT to operate again.

See the *Unidrive SP Advanced User Guide* for more information on Pr 10.30, Pr 10.31, Pr 10.37 and Pr 10.39.

This software overload protection should be used in addition to an external overload protection device.

## 4.10 Ground leakage

The ground leakage current depends upon whether the internal EMC filter is fitted. The drive is supplied with the filter fitted. Instructions for removing the internal filter are given in Figure 4-24 *Removal of internal EMC filter (size 1 to 3)* and Figure 4-25 *Removal of internal EMC filter (sizes 4 to 6)* on page 84.

### With internal filter fitted:

- 28mA AC at 400V 50Hz (proportional to supply voltage and frequency)
- 30µA DC (10MΩ)

### With internal filter removed:

<1mA

Note that in both cases there is an internal voltage surge protection device connected to ground. Under normal circumstances this carries negligible current.

When the internal filter is fitted the leakage current is high. In this case a permanent fixed ground connection must be provided, or other suitable measures taken to prevent a safety hazard occurring if the connection is lost.

### 4.10.1 Use of residual current device (RCD)

There are three common types of ELCB / RCD:

1. AC - detects AC fault currents
2. A - detects AC and pulsating DC fault currents (provided the DC current reaches zero at least once every half cycle)
3. B - detects AC, pulsating DC and smooth DC fault currents
  - Type AC should never be used with drives.
  - Type A can only be used with single phase drives
  - Type B must be used with three phase drives

Only type B ELCB / RCD are suitable for use with 3 phase inverter drives.

If an external EMC filter is used, a delay of at least 50ms should be incorporated to ensure spurious trips are not seen. The leakage current is likely to exceed the trip level if all of the phases are not energised simultaneously.

## 4.11 EMC (Electromagnetic compatibility)

The requirements for EMC are divided into three levels in the following three sections:

**Section 4.11.3, General requirements** for all applications, to ensure reliable operation of the drive and minimise the risk of disturbing nearby equipment. The immunity standards specified in section 11 will be met, but no specific emission standards. Note also the special requirements given in *Surge immunity of control circuits - long cables and connections outside a building* on page 90 for increased surge immunity of control circuits where control wiring is extended.

**Section 4.11.4, Requirements for meeting the EMC standard for power drive systems, IEC61800-3 (EN61800-3).**

**Section 4.11.5, Requirements for meeting the generic emission standards** for the industrial environment, IEC61000-6-4, EN61000-6-4, EN50081-2.

The recommendations of section 4.11.3 will usually be sufficient to avoid causing disturbance to adjacent equipment of industrial quality. If particularly sensitive equipment is to be used nearby, or in a non-industrial environment, then the recommendations of section 4.11.4 or section 4.11.5 should be followed to give reduced radio-frequency emission.

In order to ensure the installation meets the various emission standards described in:

- The EMC data sheet available from the supplier of the drive
- The Declaration of Conformity at the front of this manual
- Chapter 12 *Technical Data* on page 257

...the correct external EMC filter must be used and all of the guidelines in section 4.11.3 *General requirements for EMC* and section 4.11.5 *Compliance with generic emission standards* must be followed.

**Table 4-14 Unidrive SP and EMC filter cross reference**

| Drive            | Schaffner   | Epcos       |
|------------------|-------------|-------------|
|                  | CT part no. | CT part no. |
| SP1201 to SP1202 | 4200-6118   | 4200-6121   |
| SP1203 to SP1204 | 4200-6119   | 4200-6120   |
| SP2201 to SP2203 | 4200-6210   | 4200-6211   |
| SP3201 to SP3202 | 4200-6307   | 4200-6306   |
| SP4201 to SP4203 | 4200-6406   | 4200-6405   |
| SP1401 to SP1404 | 4200-6118   | 4200-6121   |
| SP1405 to SP1406 | 4200-6119   | 4200-6120   |
| SP2401 to SP2404 | 4200-6210   | 4200-6211   |
| SP3401 to SP3403 | 4200-6305   | 4200-6306   |
| SP4401 to SP4403 | 4200-6406   | 4200-6405   |
| SP5401 to SP5402 | 4200-6503   | 4200-6501   |
| SP6401 to SP6402 | 4200-6603   | 4200-6601   |
| SP3501 to SP3507 | 4200-6309   | 4200-6308   |
| SP4601 to SP4606 | 4200-6408   | 4200-6407   |
| SP5601 to SP5602 | 4200-6504   | 4200-6502   |
| SP6601 to SP6602 | 4200-6604   | 4200-6602   |



**High ground leakage current**

When an EMC filter is used, a permanent fixed ground connection must be provided which does not pass through a connector or flexible power cord. This includes the internal EMC filter.

**NOTE**

The installer of the drive is responsible for ensuring compliance with the EMC regulations that apply where the drive is to be used.

**4.11.1 Grounding hardware**

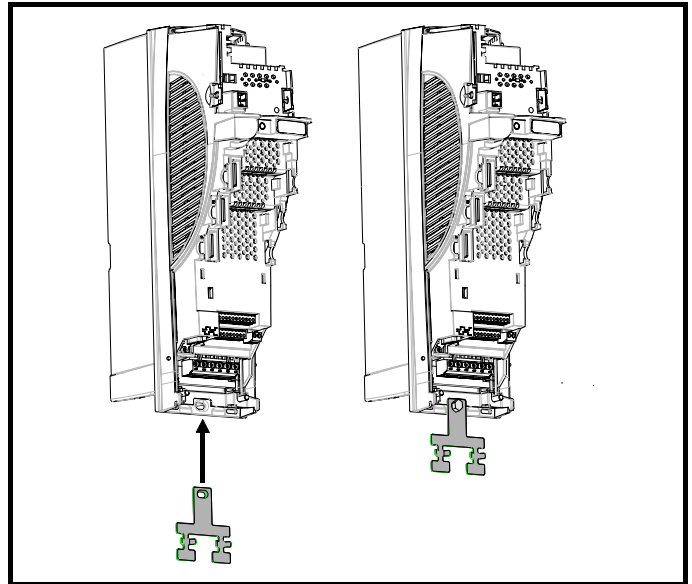
The Unidrive SP is supplied with a grounding bracket, and sizes 1 to 3 with a grounding clamp, to facilitate EMC compliance. They provide a convenient method for direct grounding of cable shields without the use of "pig-tails". Cable shields can be bared and clamped to the grounding bracket using metal clips or clamps<sup>1</sup> (not supplied) or cable ties. Note that the shield must in all cases be continued through the clamp to the intended terminal on the drive, in accordance with the connection details for the specific signal.

<sup>1</sup> A suitable clamp is the Phoenix DIN rail mounted SK14 cable clamp (for cables with a maximum outer diameter of 14mm).

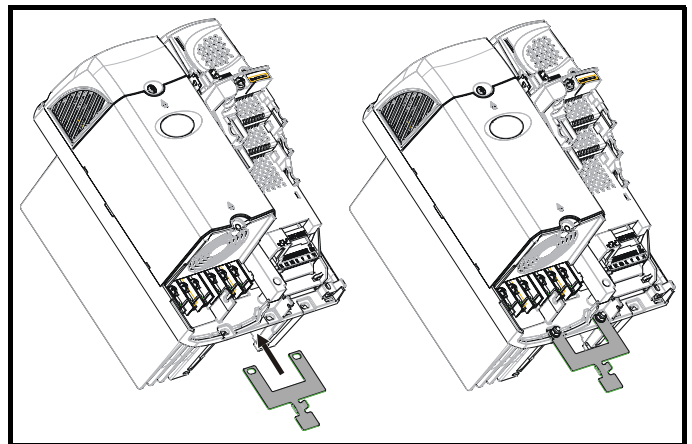
See Figure 4-19 and Figure 4-20 for details on fitting the grounding clamp.

See Figure 4-21 for details on fitting the grounding bracket.

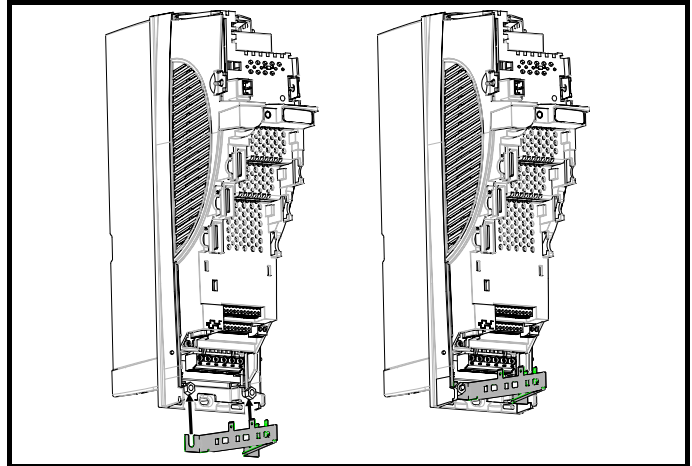
**Figure 4-19 Fitting of grounding clamp (size 1 and 2)**



**Figure 4-20 Fitting of grounding clamp (size 3)**



**Figure 4-21 Fitting of grounding bracket (sizes 1 to 6)**



Loosen the ground connection nuts and slide the grounding bracket in the direction shown. Once in place, re-tighten the ground connection nuts.

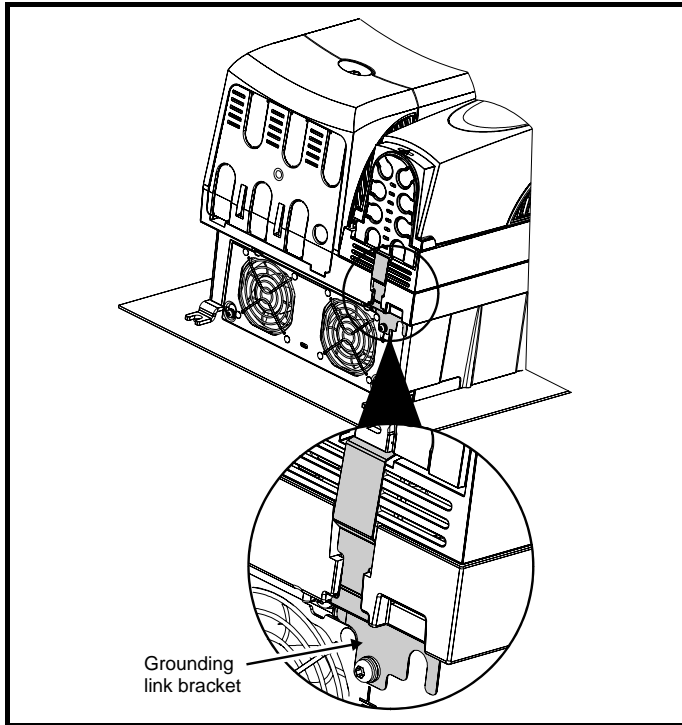


**WARNING** On Unidrive SP size 1 and 2, the grounding bracket is secured using the power ground terminal of the drive. Ensure that the supply ground connection is secure after fitting / removing the grounding bracket. Failure to do so will result in the drive not being grounded.

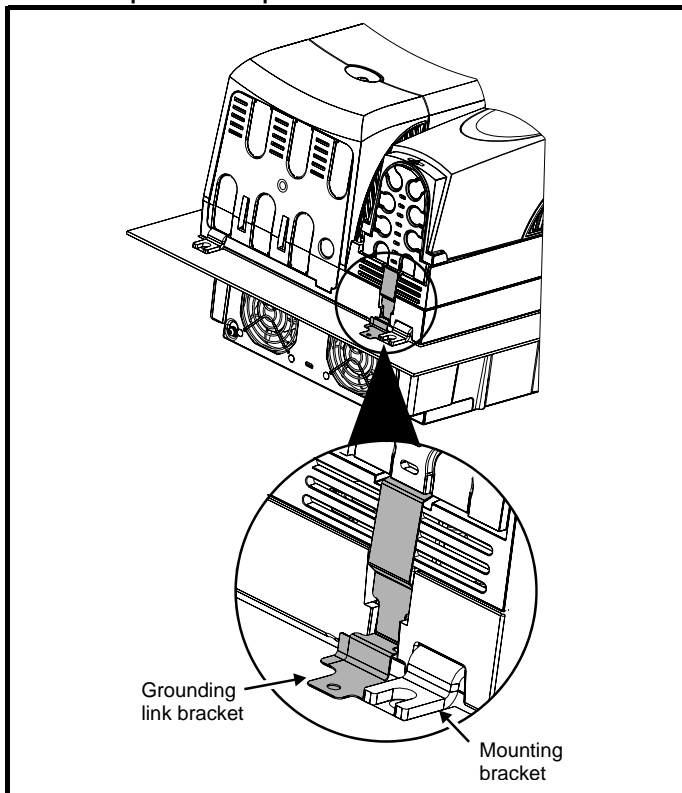
A faston tab is located on the grounding bracket for the purpose of connecting the drive 0V to ground should the user require to do so.

When a Unidrive SP size 4 or 5 is through-panel mounted, the grounding link bracket must be folded upwards. A screw can be used to secure the bracket or it can be located under the mounting bracket to ensure that a ground connection is made. This is required to provide a grounding point for the grounding bracket as shown in Figure 4-21.

**Figure 4-22** Grounding link bracket in its surface mount position (as supplied)



**Figure 4-23** Grounding link bracket folded up into its through-panel mount position



### 4.11.2 Internal EMC filter

It is recommended that the internal EMC filter be kept in place unless there is a specific reason for removing it.



For frame sizes 3 and above, when the Unidrive SP is used with ungrounded (IT) supplies the internal EMC filter must be removed unless additional motor ground fault protection is fitted or, in the case of size 3 only, the external filter is also used.

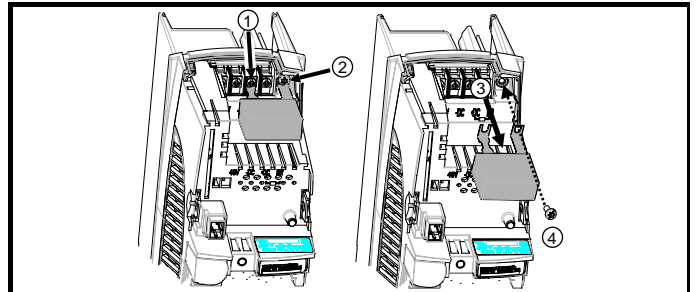
For instructions on removal, refer to Figure 4-24 and Figure 4-25.

For details of ground fault protection contact the supplier of the drive.

If the drive is used as part of a regen system, then the internal EMC filter must be removed.

The internal EMC filter reduces radio-frequency emission into the mains supply. Where the motor cable is short, it permits the requirements of EN61800-3 to be met for the second environment - see section 4.11.4 *Compliance with EN 61800-3 (standard for Power Drive Systems)* on page 87 and section 12.1.23 *Electromagnetic compatibility (EMC)* on page 270. For longer motor cables the filter continues to provide a useful reduction in emission level, and when used with any length of shielded motor cable up to the limit for the drive, it is unlikely that nearby industrial equipment will be disturbed. It is recommended that the filter be used in all applications unless the instructions given above require it to be removed or the ground leakage current of 28mA is unacceptable. See Figure 4-24 and Figure 4-25 for details of removing and fitting the internal EMC filter.

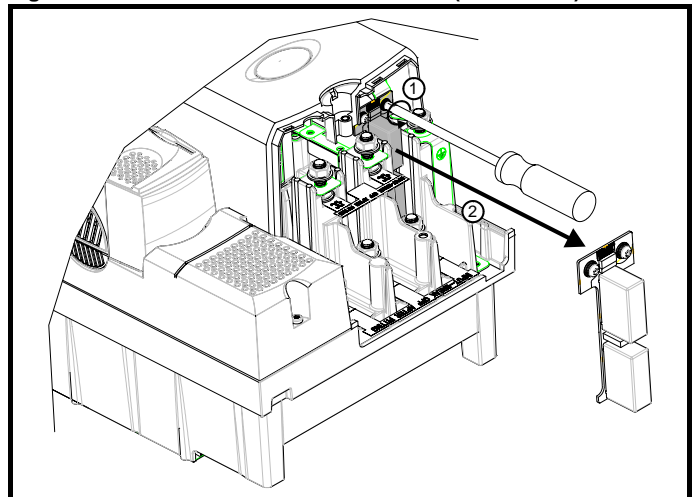
**Figure 4-24** Removal of internal EMC filter (size 1 to 3)



Loosen / remove screws as shown (1) and (2).

Remove filter (3), and ensure the screws are replaced and re-tightened (4).

**Figure 4-25** Removal of internal EMC filter (sizes 4 to 6)



Loosen screws (1). Remove EMC filter in the direction shown (2).

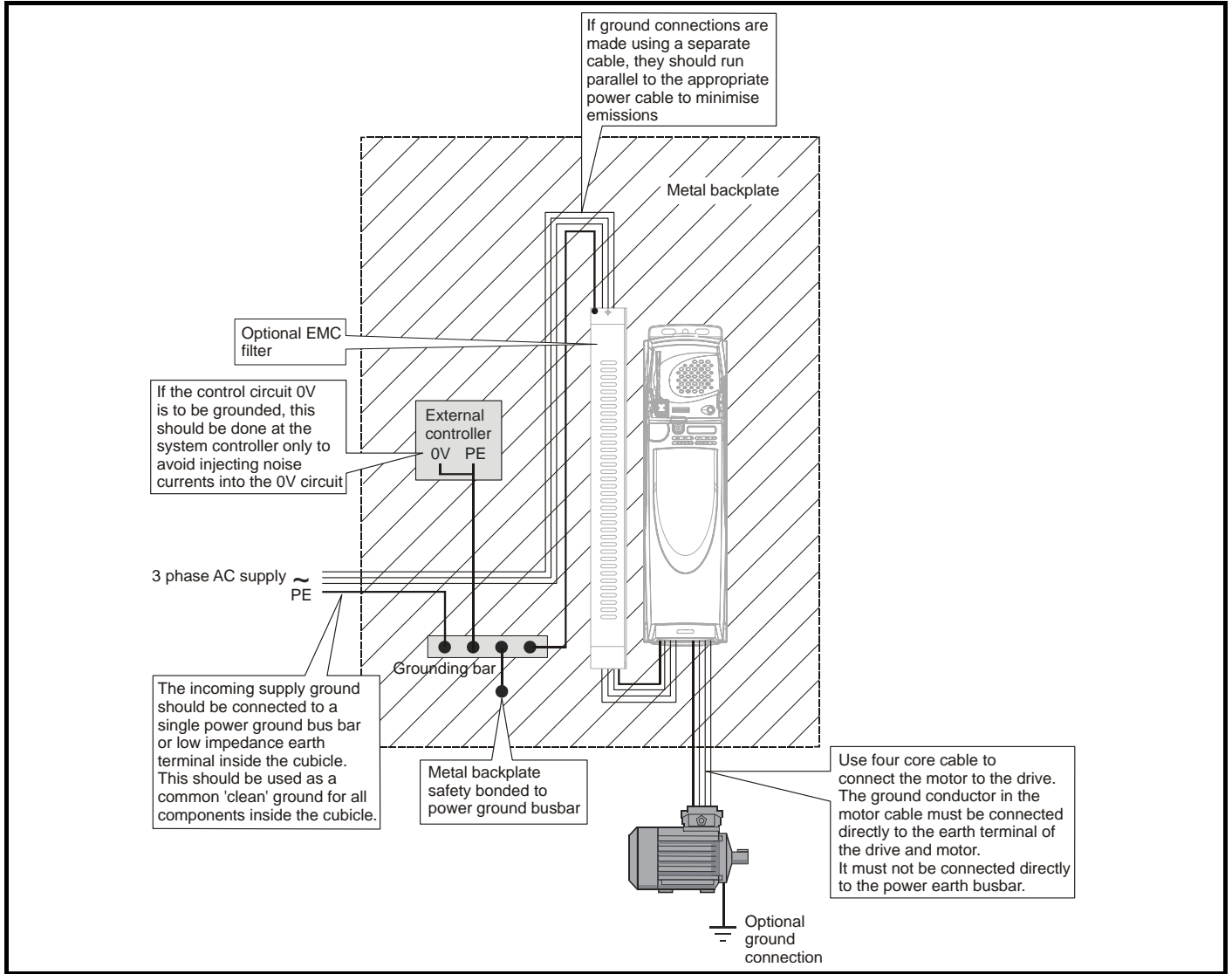
### 4.11.3 General requirements for EMC

#### Ground (earth) connections

The grounding arrangements should be in accordance with Figure 4-26, which shows a single drive on a back-plate with or without an additional enclosure.

Figure 4-26 shows how to manage EMC when using an unshielded motor cable. However a shielded cable is preferable, in which case it should be installed as shown in section 4.11.5 *Compliance with generic emission standards* on page 88.

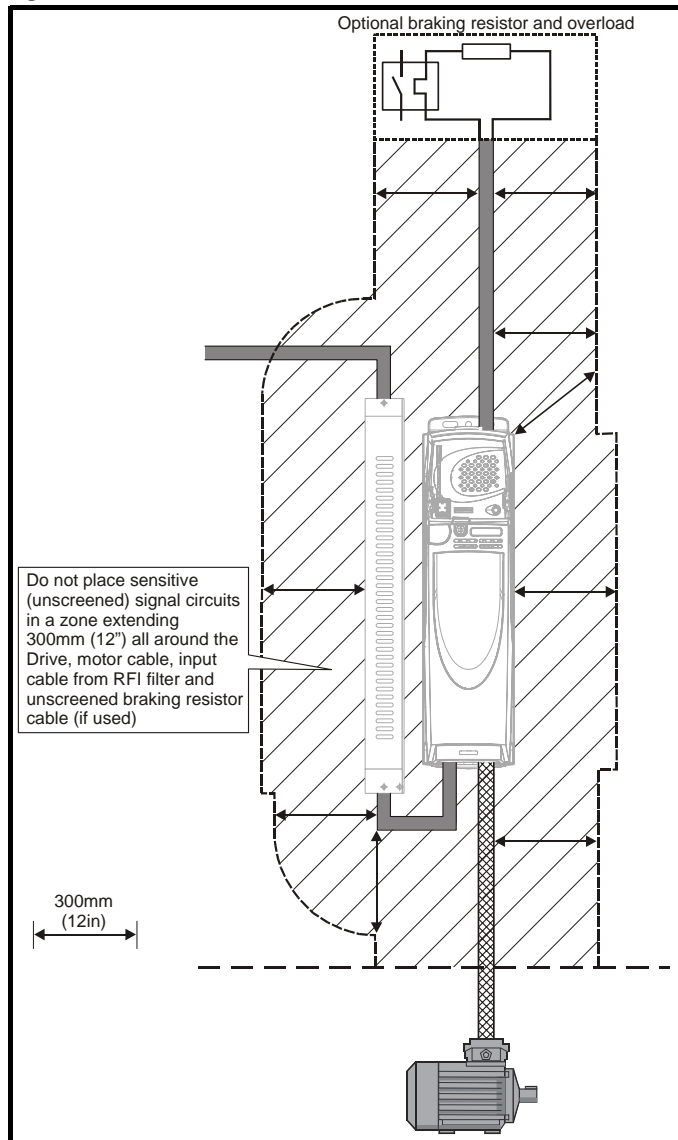
**Figure 4-26 General EMC enclosure layout showing ground connections**



## Cable layout

Figure 4-27 indicates the clearances which should be observed around the drive and related 'noisy' power cables by all sensitive control signals / equipment.

**Figure 4-27 Drive cable clearances**



### NOTE

Any signal cables which are carried inside the motor cable (i.e. motor thermistor, motor brake) will pick up large pulse currents via the cable capacitance. The screen of these signal cables must be connected to ground close to the motor cable, to avoid this noise current spreading through the control system.

## Feedback device cable shielding

Shielding considerations are important for PWM drive installations due to the high voltages and currents present in the output (motor) circuit with a very wide frequency spectrum, typically from 0 to 20 MHz.

The following guidance is divided into two parts:

1. Ensuring correct transfer of data without disturbance from electrical noise originating either within the drive or from outside.
2. Additional measures to prevent unwanted emission of radio frequency noise. These are optional and only required where the installation is subject to specific requirements for radio frequency emission control.

## To ensure correct transfer of data, observe the following:

### Resolver connections:

- Use a cable with an overall shield and twisted pairs for the resolver signals
- Connect the cable shield to the drive 0V connection by the shortest possible link ("pigtail")
- It is generally preferable not to connect the cable shield to the resolver. However in cases where there is an exceptional level of common-mode noise voltage present on the resolver body, it may be helpful to connect the shield there. If this is done then it becomes essential to ensure the absolute minimum length of "pigtails" at both shield connections, and possibly to clamp the cable shield directly to the resolver body and to the drive grounding bracket.
- The cable should preferably not be interrupted. If interruptions are unavoidable, ensure the absolute minimum length of "pigtail" in the shield connections at each interruption.

### Encoder connections:

- Use a cable with the correct impedance
- Use a cable with individually shielded twisted pairs
- Connect the cable shields to 0V at both the drive and the encoder, using the shortest possible links ("pigtails")
- The cable should preferably not be interrupted. If interruptions are unavoidable, ensure the absolute minimum length of "pigtail" in the shield connections at each interruption. Preferably, use a connection method which provides substantial metallic clamps for the cable shield terminations.

The above applies where the encoder body is isolated from the motor and where the encoder circuit is isolated from the encoder body. Where there is no isolation between the encoder circuits and the motor body, and in case of doubt, the following additional requirement must be observed. This gives the best possible noise immunity.

- The shields must be directly clamped to the encoder body (no pigtail) and to the drive grounding bracket. This may be achieved by clamping of the individual shields or by providing an additional overall shield which is clamped.

### NOTE

The recommendations of the encoder manufacturer must also be adhered to for the encoder connections.

### NOTE

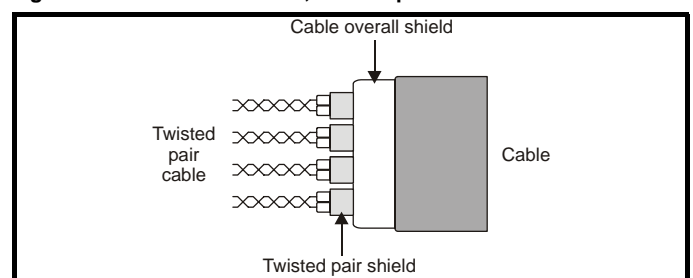
In order to guarantee maximum noise immunity for any application double screened cable as shown should be used.

In some cases single shielding of each pair of differential signals cables, or a single overall shield with individual shield on the thermistor connections is sufficient. In these cases all the shields should be connected to ground and 0V at both ends.

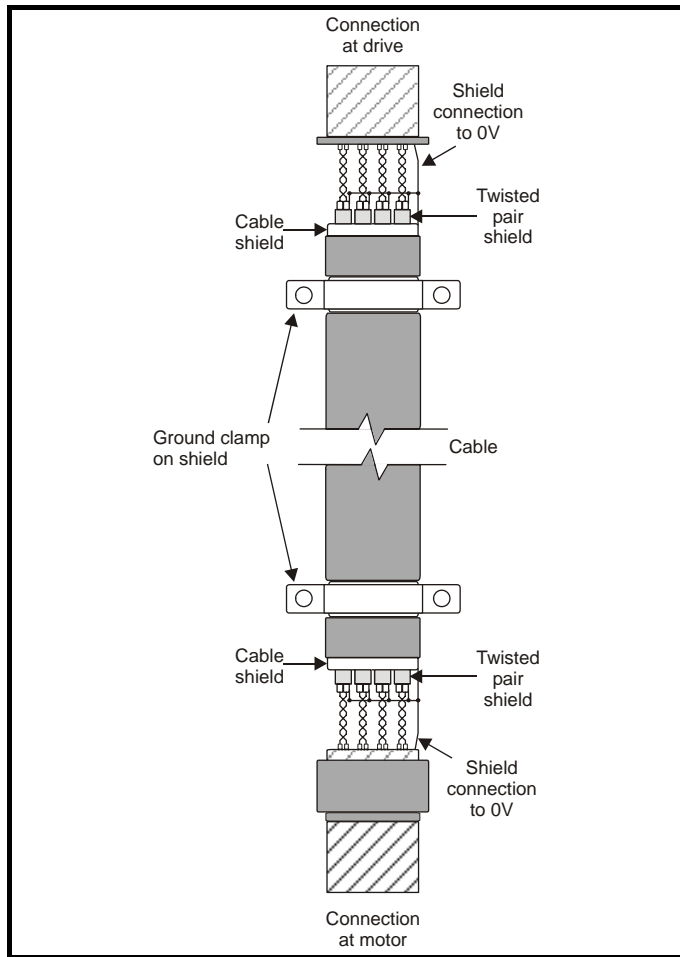
If the 0V is required to be left floating a cable with individual shields and an overall shield must be used.

Figure 4-28 and Figure 4-29 illustrate the preferred construction of cable and the method of clamping. The outer sheath of the cable should be stripped back enough to allow the clamp to be fitted. The shield must not be broken or opened at this point. The clamps should be fitted close to the drive or feedback device, with the ground connections made to a ground plate or similar metallic ground surface.

**Figure 4-28 Feedback cable, twisted pair**



**Figure 4-29 Feedback cable connections**



**To ensure suppression of radio frequency emission, observe the following:**

- Use a cable with an overall shield
- Clamp the overall shield to grounded metallic surfaces at both the encoder and the drive, as illustrated in Figure 4-29

**4.11.4 Compliance with EN 61800-3 (standard for Power Drive Systems)**

Meeting the requirements of this standard depends on the environment that the drive is intended to operate in, as follows:

**Operation in the first environment**

Observe the guidelines given in section 4.11.5 *Compliance with generic emission standards* on page 88. An external EMC filter will always be required.

This is a product of the restricted distribution class according to IEC 61800-3  
In a domestic environment this product may cause radio interference in which case the user may be required to take adequate measures.

**Operation in the second environment**

In all cases a shielded motor cable must be used, and an EMC filter is required for all Unidrive SPs with a rated input current of less than 100A.

The drive contains an in-built filter for basic emission control. In some cases feeding the motor cables (U, V and W) once through a ferrite ring can maintain compliance for longer cable lengths. The requirements of operating in the second environment are met, depending on the motor cable length for 3kHz switching frequency as stated in Table 4-15.

**Table 4-15 Second environment emission compliance**

| Drive size | Filter                    | Voltage | Motor cable length (m) |            |            |            |
|------------|---------------------------|---------|------------------------|------------|------------|------------|
|            |                           |         | 0 to 2                 | 2 to 4     | 4 to 10    | > 10       |
| 1          | In-built                  | Any     | Unrestricted           | Restricted |            |            |
|            | In-built and ferrite ring | Any     | Unrestricted           |            | Restricted |            |
| 2          | In-built                  | Any     | Restricted             |            |            |            |
|            | In-built and ferrite ring | Any     | Unrestricted           |            | Restricted |            |
| 3          | In-built                  | Any     | Restricted             |            |            |            |
|            | In-built and ferrite ring | Any     | Unrestricted           |            | Restricted |            |
| 4          | In-built                  | Any     | Restricted             |            |            |            |
| 5          | In-built                  | 400     | Unrestricted           |            | Restricted |            |
|            | In-built                  | 600     | Unrestricted           |            | Restricted |            |
| 6          | In-built                  | Any     | Unrestricted           |            |            | Restricted |
| 8          | In-built                  | Any     |                        |            |            |            |
| 9          | In-built                  | Any     |                        |            |            |            |

**Key:**

Restricted: EN 61800-3 second environment, restricted distribution (Additional measures may be required to prevent interference)

Unrestricted: EN 61800-3 second environment, unrestricted distribution

For longer motor cables, an external filter is required. Where a filter is required, follow the guidelines in section 4.11.5 *Compliance with generic emission standards*.

Where a filter is not required, follow the guidelines given in section 4.11.3 *General requirements for EMC* on page 85.

The second environment typically includes an industrial low-voltage power supply network which does not supply buildings used for domestic purposes. Operating the drive in this environment without an external EMC filter may cause interference to nearby electronic equipment whose sensitivity has not been appreciated. The user must take remedial measures if this situation arises. If the consequences of unexpected disturbances are severe, it is recommended that the guidelines in section 4.11.5 *Compliance with generic emission standards* be adhered to.

Refer to section 12.1.23 *Electromagnetic compatibility (EMC)* on page 270 for further information on compliance with EMC standards and definitions of environments.

Detailed instructions and EMC information are given in the *Unidrive SP EMC Data Sheet* which is available from the supplier of the drive.

### 4.11.5 Compliance with generic emission standards

The following information applies to frame sizes 1 to 5.

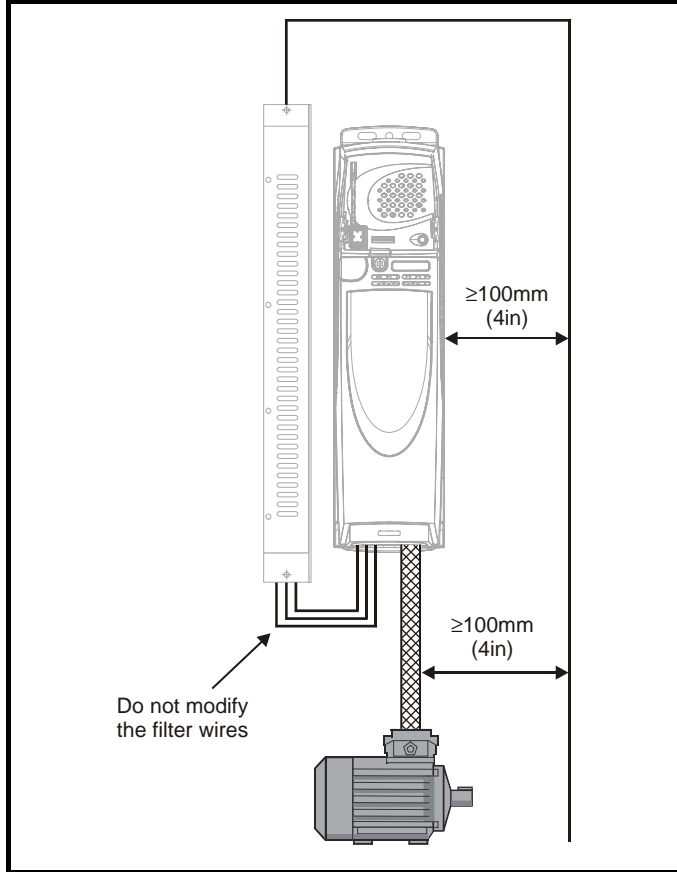
Size 6 upwards does not comply with the requirements of the generic standards for radiated emission.

Size 6 complies with the requirements for conducted emission.

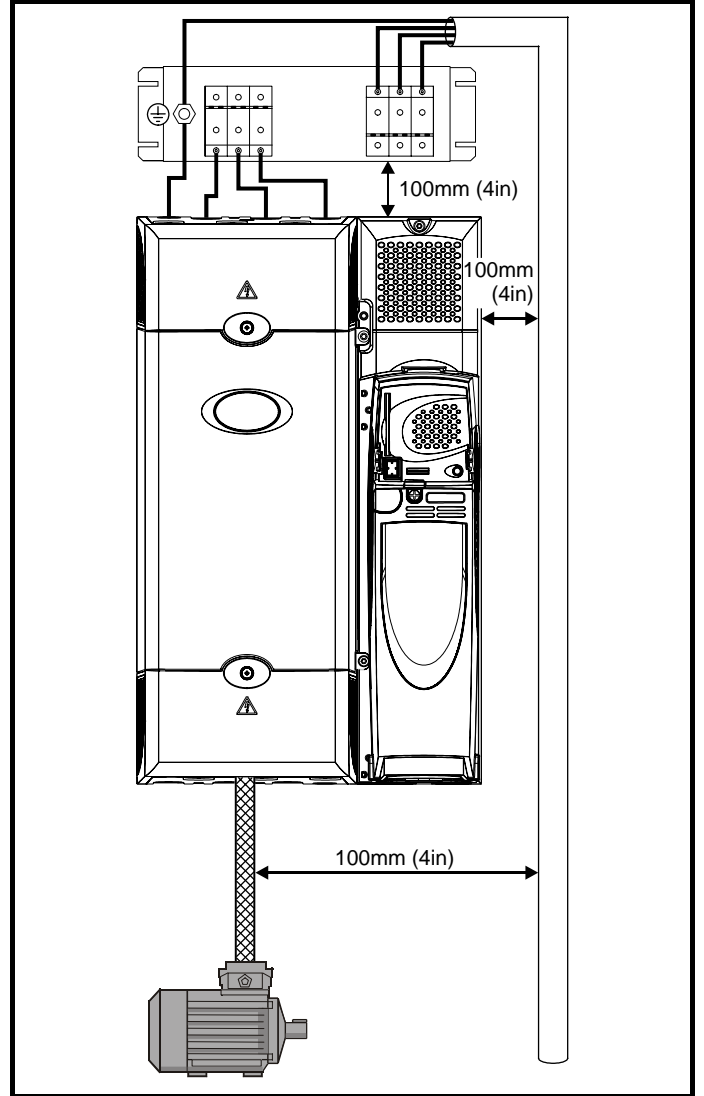
Sizes 8 and 9 are under consideration.

Use the recommended filter and shielded motor cable. Observe the layout rules given in Figure 4-30. Ensure the AC supply and ground cables are at least 100mm from the power module and motor cable.

**Figure 4-30 Supply and ground cable clearance (size 1 to 3)**

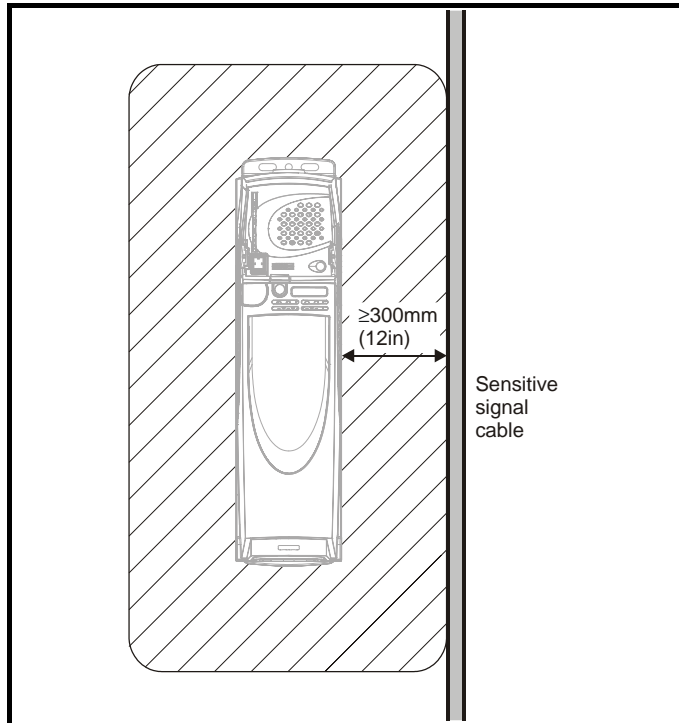


**Figure 4-31 Supply and ground cable clearance (size 4 to 6)**



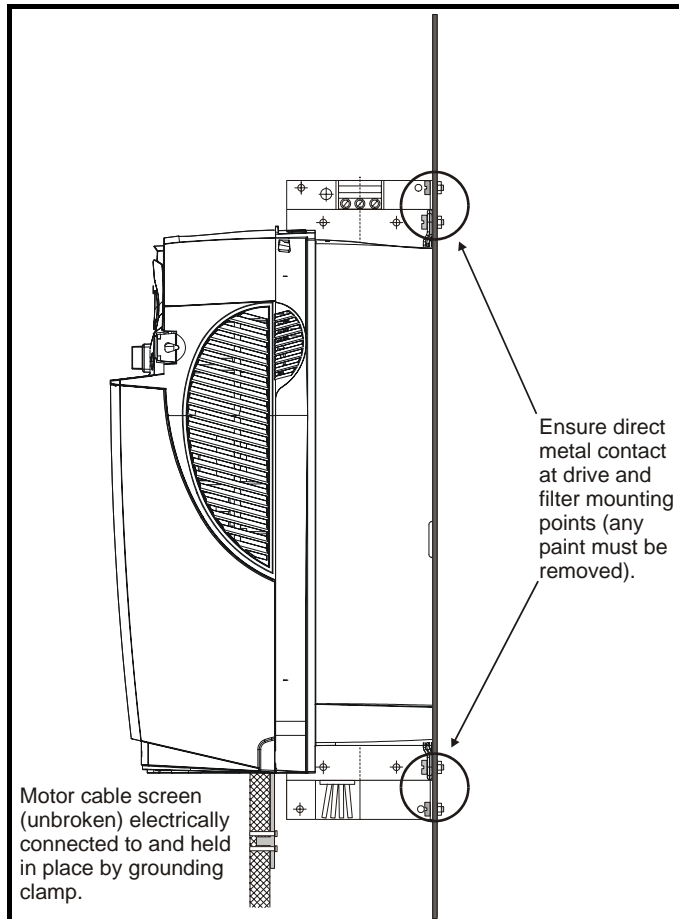
Avoid placing sensitive signal circuits in a zone 300mm (12in) all around the power module.

**Figure 4-32 Sensitive signal circuit clearance**



Ensure good EMC grounding.

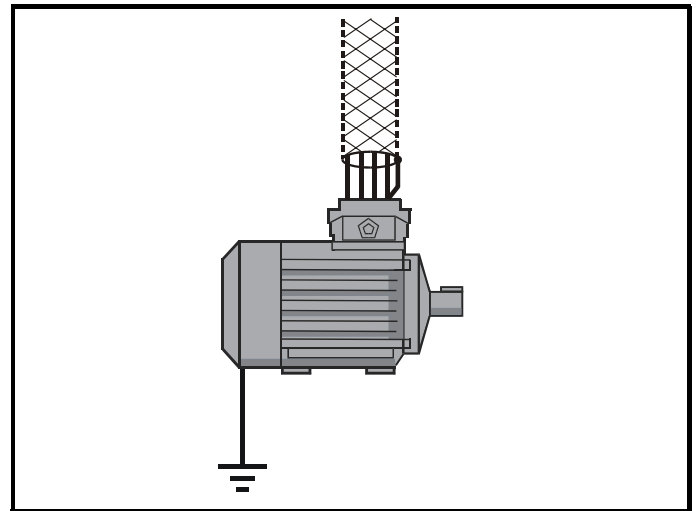
**Figure 4-33 Grounding the drive, motor cable shield and filter**



Connect the shield of the motor cable to the ground terminal of the motor frame using a link that is as short as possible and not exceeding 50mm (2in) long. A full 360° termination of the shield to the terminal housing of the motor is beneficial.

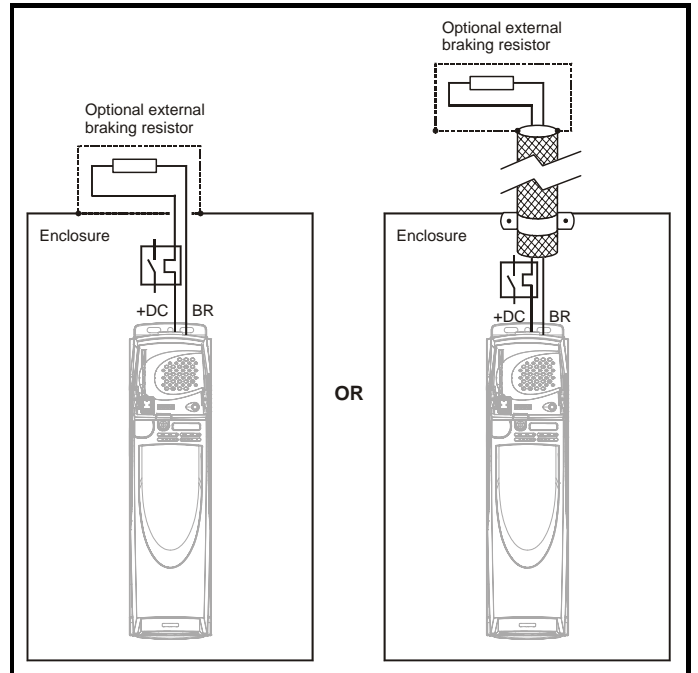
It is unimportant for EMC purposes whether the motor cable contains an internal (safety) ground core, or there is a separate external ground conductor, or grounding is through the shield alone. An internal ground core will carry a high noise current and therefore it must be terminated as close as possible to the shield termination.

**Figure 4-34 Grounding the motor cable shield**



Unshielded wiring to the optional braking resistor(s) may be used, provided the wiring does not run external to the enclosure. Ensure a minimum spacing of 300mm (12in) from signal wiring and the AC supply wiring to the external EMC filter. Otherwise this wiring must be shielded.

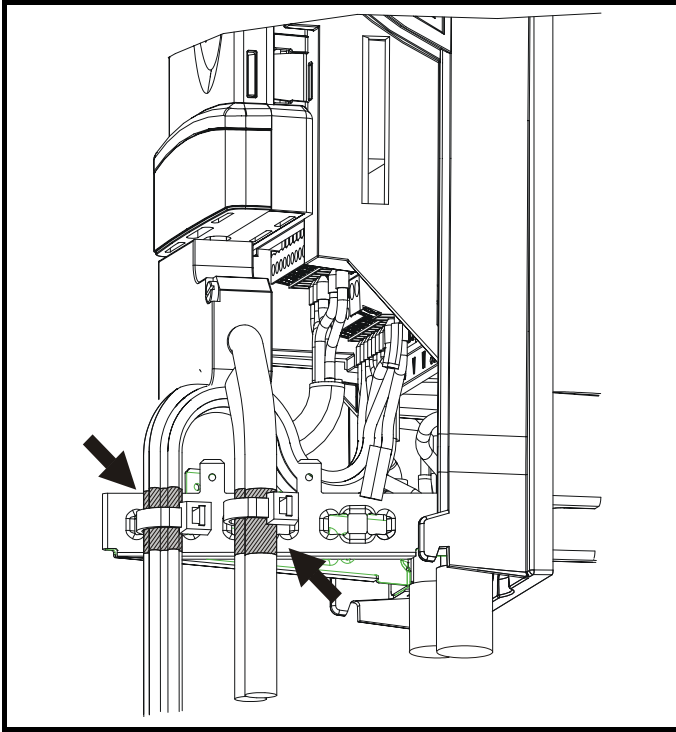
**Figure 4-35 Shielding requirements of optional external braking resistor**



If the control wiring is to leave the enclosure, it must be shielded and the shield(s) clamped to the drive using the grounding bracket as shown in Figure 4-36. Remove the outer insulating cover of the cable to ensure the shield(s) make contact with the bracket, but keep the shield(s) intact until as close as possible to the terminals

Alternatively, wiring may be passed through a ferrite ring, part no. 3225-1004.

**Figure 4-36** Grounding of signal cable shields using the grounding bracket



#### 4.11.6 Variations in the EMC wiring interruptions to the motor cable

The motor cable should ideally be a single length of shielded or armoured cable having no interruptions. In some situations it may be necessary to interrupt the cable, as in the following examples:

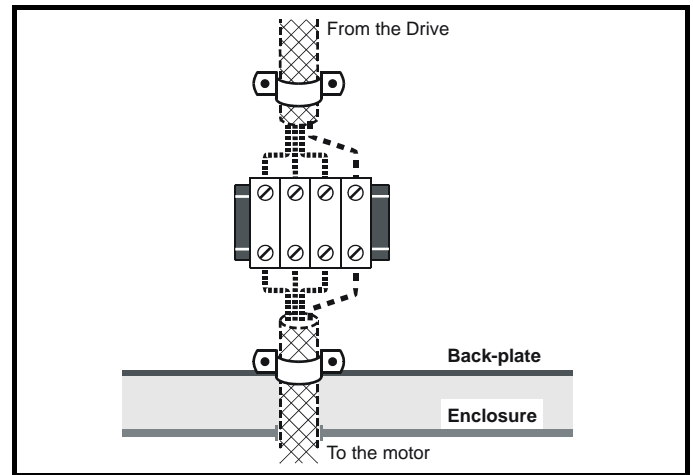
- Connecting the motor cable to a terminal block in the drive enclosure
- Fitting a motor isolator switch for safety when work is done on the motor

In these cases the following guidelines should be followed.

##### Terminal block in the enclosure

The motor cable shields should be bonded to the back-plate using uninsulated metal cable-clamps which should be positioned as close as possible to the terminal block. Keep the length of power conductors to a minimum and ensure that all sensitive equipment and circuits are at least 0.3m (12 in) away from the terminal block.

**Figure 4-37** Connecting the motor cable to a terminal block in the enclosure



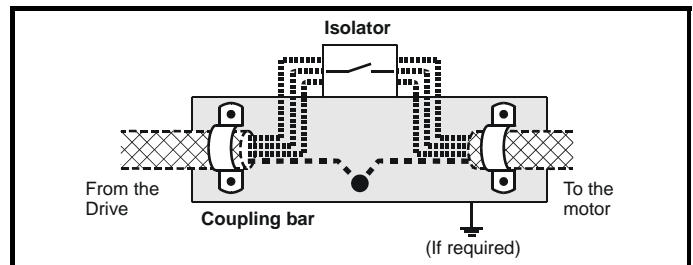
##### Using a motor isolator-switch

The motor cable shields should be connected by a very short conductor having a low inductance. The use of a flat metal coupling-bar is recommended; conventional wire is not suitable.

The shields should be bonded directly to the coupling-bar using uninsulated metal cable-clamps. Keep the length of the exposed power conductors to a minimum and ensure that all sensitive equipment and circuits are at least 0.3m (12 in) away.

The coupling-bar may be grounded to a known low-impedance ground nearby, for example a large metallic structure which is connected closely to the drive ground.

**Figure 4-38** Connecting the motor cable to an isolator switch



##### Surge immunity of control circuits - long cables and connections outside a building

The input/output ports for the control circuits are designed for general use within machines and small systems without any special precautions.

These circuits meet the requirements of EN61000-6-2 (1kV surge) provided the 0V connection is not grounded.

In applications where they may be exposed to high-energy voltage surges, some special measures may be required to prevent malfunction or damage. Surges may be caused by lightning or severe power faults in association with grounding arrangements which permit high transient voltages between nominally grounded points. This is a particular risk where the circuits extend outside the protection of a building.

As a general rule, if the circuits are to pass outside the building where the drive is located, or if cable runs within a building exceed 30m, some additional precautions are advisable. One of the following techniques should be used:

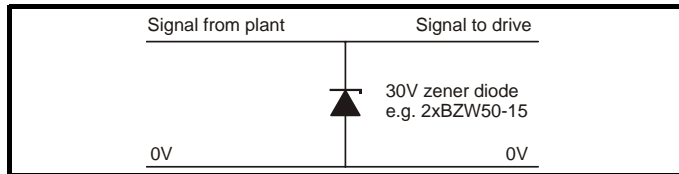
1. Galvanic isolation, i.e. do not connect the control 0V terminal to ground. Avoid loops in the control wiring, i.e. ensure every control wire is accompanied by its return (0V) wire.
2. Shielded cable with additional power ground bonding. The cable shield may be connected to ground at both ends, but in addition the ground conductors at both ends of the cable must be bonded together by a power ground cable (equipotential bonding cable) with

cross-sectional area of at least 10mm<sup>2</sup>, or 10 times the area of the signal cable shield, or to suit the electrical safety requirements of the plant. This ensures that fault or surge current passes mainly through the ground cable and not in the signal cable shield. If the building or plant has a well-designed common bonded network this precaution is not necessary.

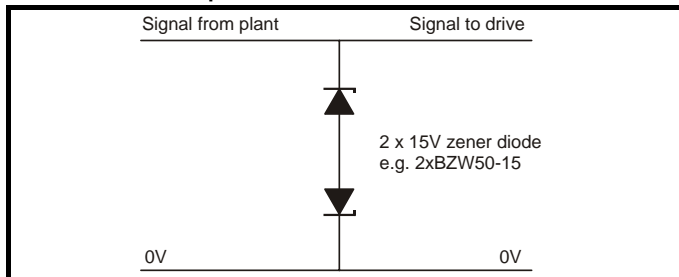
- Additional over-voltage suppression - for the analogue and digital inputs and outputs, a zener diode network or a commercially available surge suppressor may be connected in parallel with the input circuit as shown in Figure 4-39 and Figure 4-40.

If a digital port experiences a severe surge its protective trip may operate (O.Ld1 trip code 26). For continued operation after such an event, the trip can be reset automatically by setting Pr 10.34 to 5.

**Figure 4-39 Surge suppression for digital and unipolar inputs and outputs**



**Figure 4-40 Surge suppression for analogue and bipolar inputs and outputs**



Surge suppression devices are available as rail-mounting modules, e.g. from Phoenix Contact:

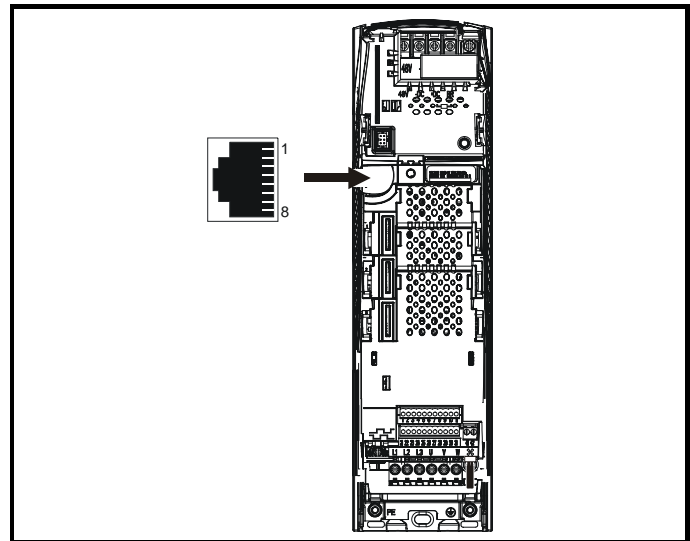
- Unipolar TT-UKK5-D/24 DC
- Bipolar TT-UKK5-D/24 AC

These devices are not suitable for encoder signals or fast digital data networks because the capacitance of the diodes adversely affects the signal. Most encoders have galvanic isolation of the signal circuit from the motor frame, in which case no precautions are required. For data networks, follow the specific recommendations for the particular network.

## 4.12 Serial communications connections

The Unidrive SP has a serial communications port (serial port) as standard supporting 2 wire EIA485 communications. Please see Table 4-16 for the connection details for the RJ45 connector.

**Figure 4-41 Location of the RJ45 serial comms connector**



**Table 4-16 Connection details for RJ45 connector**

| Pin   | Function   |
|-------|--|
| 1     | 120Ω Termination resistor                                      |
| 2     | RX TX  |
| 3     | Isolated 0V  |
| 4     | +24V (100mA)   |
| 5     | Isolated 0V  |
| 6     | TX enable  |
| 7     | RX\ TX\  |
| 8     | RX\ TX\ (if termination resistors are required, link to pin 1) |
| Shell | Isolated 0V  |

The communications port applies a 2 unit load to the communications network.

Minimum number of connections are 2, 3, 7 and shield. Shielded cable must be used at all times.

### 4.12.1 Isolation of the serial communications port

The serial communications port of the Unidrive SP is double insulated and meets the requirements for SELV in EN50178.

In order to meet the requirements for SELV in IEC60950 (IT equipment) it is necessary for the control computer to be grounded. Alternatively, when a lap-top or similar device is used which has no provision for grounding, an isolation device must be incorporated in the communications lead.

**WARNING**

An isolated serial communications lead has been designed to connect the Unidrive SP to IT equipment (such as lap-top computers), and is available from the supplier of the drive. See below for details:

**Table 4-17 Isolated serial comms lead details**

| Part number | Description    |
|-------------|----------------|
| 4500-0087   | CT Comms cable |

The "isolated serial communications" lead has reinforced insulation as defined in IEC60950 for altitudes up to 3,000m.

**NOTE**

When using the CT Comms cable the available baud rate is limited to 19.2k baud.

## 4.12.2 Multi-drop network

The Unidrive SP can be used on a 2 wire EIA485 multi-drop network using the drive's serial communications port when the following guidelines are adhered to.

### Connections

The network should be a daisy chain arrangement and not a star, although short stubs to the drive are allowed.

The minimum connections are pins 2 (RX TX), 3 (isolated 0V), 7 (RX TX) and the screen.

Pin 4 (+24V) on each drive can be connected together but there is no power sharing mechanism between drives and therefore the maximum power available is the same as a single drive. (If pin 4 is not linked to the other drives on the network and has an individual load then the maximum power can be taken from pin 4 of each drive.)

### Termination resistors

If a drive is on the end of the network chain then pins 1 and 8 should be linked together. This will connect an internal 120Ω termination resistor between RXTX and RX\TX. (If the end unit is not a drive or the user wishes to use their own termination resistor, a 120Ω termination resistor should be connected between RXTX and RX\TX at the end unit.)

If the host is connected to a single drive then termination resistors should not be used unless the baud rate is high.

### CT Comms Cable

The CT Comms Cable can be used on a multi-drop network but should only be used occasionally for diagnostic and set up purposes. The network must also be made up entirely of Unidrive SPs.

If the CT Comms Cable is to be used, then pin 6 (TX enable) should be connected on all drives and pin 4 (+24V) should be linked to at least 1 drive to supply power to the converter in the cable.

Only one CT Comms Cable can be used on a network.

## 4.13 Control connections

### 4.13.1 General

Table 4-18 The Unidrive SP control connections consist of:

| Function                      | Qty | Control parameters available   | Terminal number      |
|-------------------------------|-----|--|----------------------|
| Differential analogue input   | 1   | Destination, offset, offset trim, invert, scaling                      | 5,6                  |
| Single ended analogue input   | 2   | Mode, offset, scaling, invert, destination                             | 7,8                  |
| Analogue output               | 2   | Source, mode, scaling,   | 9,10                 |
| Digital input                 | 3   | Destination, invert, logic select                                      | 27,28,29             |
| Digital input / output        | 3   | Input / output mode select, destination / source, invert, logic select | 24,25,26             |
| Relay                         | 1   | Source, invert   | 41,42                |
| Drive enable (Secure Disable) | 1   |  | 31                   |
| +10V User output              | 1   |  | 4                    |
| +24V User output              | 1   | Source, invert   | 22                   |
| 0V common                     | 6   |  | 1, 3, 11, 21, 23, 30 |
| +24V External input           | 1   |  | 2                    |

#### Key:

**Destination parameter:** indicates the parameter which is being controlled by the terminal / function

**Source parameter:** indicates the parameter being output by the terminal

**Mode parameter:** analogue - indicates the mode of operation of the terminal, i.e. voltage 0-10V, current 4-20mA etc.  
digital - indicates the mode of operation of the terminal, i.e. positive / negative logic (the Drive Enable terminal is fixed in positive logic), open collector.

All analogue terminal functions can be programmed in menu 7.

All digital terminal functions (including the relay) can be programmed in menu 8.

The setting of Pr 1.14 and Pr 6.04 can cause the function of digital inputs T25 to T29 to change. For more information, please refer to section 11.21.1 *Reference modes* on page 248 and section 11.21.7 *Start / stop logic modes* on page 253.



**WARNING**

The control circuits are isolated from the power circuits in the drive by basic insulation (single insulation) only. The installer must ensure that the external control circuits are insulated from human contact by at least one layer of insulation (supplementary insulation) rated for use at the AC supply voltage.



**WARNING**

If the control circuits are to be connected to other circuits classified as Safety Extra Low Voltage (SELV) (e.g. to a personal computer), an additional isolating barrier must be included in order to maintain the SELV classification.



**CAUTION**

If any of the digital inputs or outputs (including the drive enable input) are connected in parallel with an inductive load (i.e. contactor or motor brake) then suitable suppression (i.e. diode or varistor) should be used on the coil of the load. If no suppression is used then over voltage spikes can cause damage to the digital inputs and outputs on the drive.



**CAUTION**

Ensure the logic sense is correct for the control circuit to be used. Incorrect logic sense could cause the motor to be started unexpectedly. Positive logic is the default state for Unidrive SP.

#### NOTE

Any signal cables which are carried inside the motor cable (i.e. motor thermistor, motor brake) will pick up large pulse currents via the cable capacitance. The shield of these signal cables must be connected to ground close to the point of exit of the motor cable, to avoid this noise current spreading through the control system.

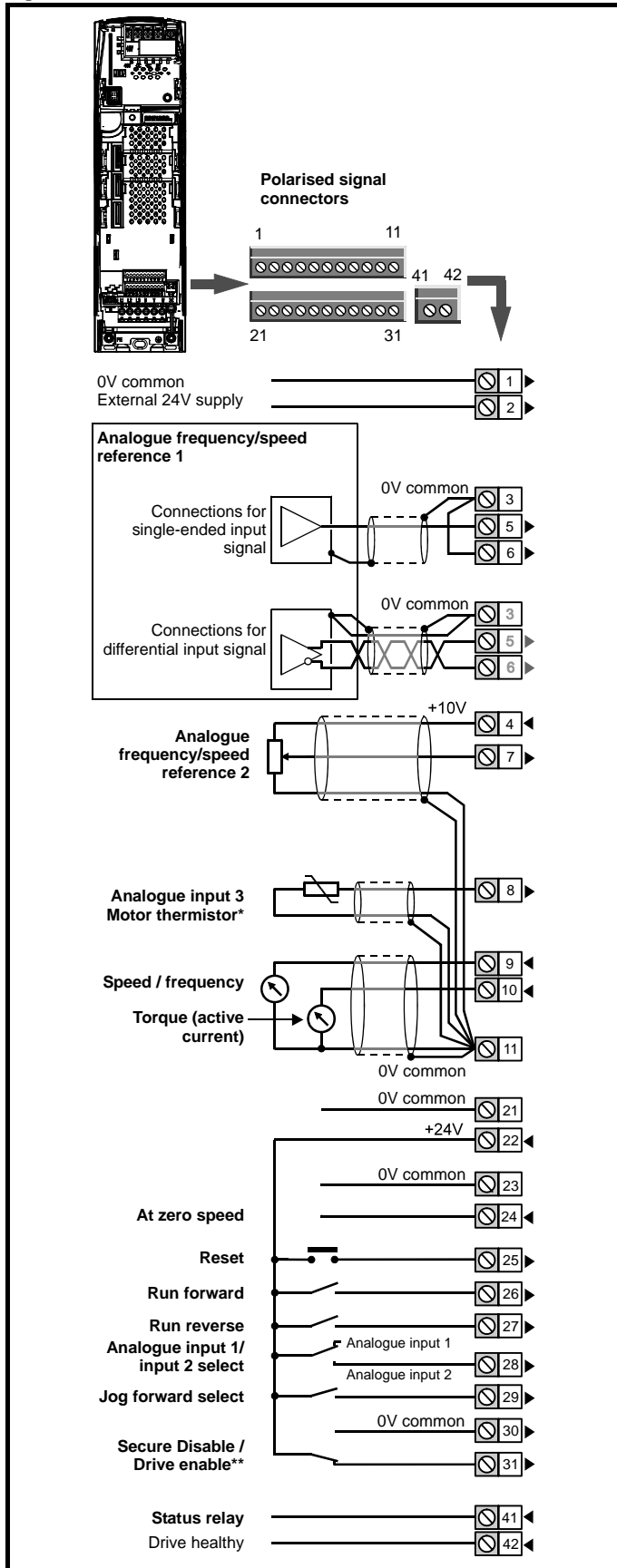
#### NOTE

The Secure Disable / drive enable terminal is a positive logic input only. It is not affected by the setting of Pr 8.29 *Positive logic select*.

#### NOTE

The common 0V from analogue signals should, wherever possible, not be connected to the same 0V terminal as the common 0V from digital signals. Terminals 3 and 11 should be used for connecting the 0V common of analogue signals and terminals 21, 23 and 30 for digital signals. This is to prevent small voltage drops in the terminal connections causing inaccuracies in the analogue signals.

Figure 4-42 Default terminal functions



\* With software V01.07.00 and later, Analogue input 3 is configured as a motor thermistor input. With software V01.06.02 and earlier, Analogue input 3 has no default function. Refer to *Analogue input 3* on page 94.

\*\*The Secure Disable / Drive enable terminal is a positive logic input only.

### 4.13.2 Control terminal specification

| 1 0V common |  |
|-------------|--|
| Function    | Common connection for all external devices |

| 2 +24V external input                |   |
|--------------------------------------|---|
| Function                             | To supply the control circuit without providing a supply to the power stage |
| Nominal voltage                      | +24.0Vdc  |
| Minimum continuous operating voltage | +19.2Vdc  |
| Maximum continuous operating voltage | +30.0Vdc  |
| Minimum start-up voltage             | 21.6Vdc   |
| Recommended power supply             | 60W 24Vdc nominal   |
| Recommended fuse                     | 3A, 50Vdc   |

| 3 0V common |  |
|-------------|--|
| Function    | Common connection for all external devices |

| 4 +10V user output     |                                      |
|------------------------|--------------------------------------|
| Function               | Supply for external analogue devices |
| Voltage tolerance      | ±1%                                  |
| Nominal output current | 10mA                                 |
| Protection             | Current limit and trip @ 30mA        |

| Precision reference Analogue input 1 |  |
|--------------------------------------|--|
| 5 Non-inverting input                |  |
| 6 Inverting input                    |  |
| Default function                     | Frequency/speed reference  |
| Type of input                        | Bipolar differential analogue (For single-ended use, connect terminal 6 to terminal 3)   |
| Full scale voltage range             | ±9.8V ±1%  |
| Absolute maximum voltage range       | ±36V relative to 0V  |
| Working common mode voltage range    | ±13V relative to 0V  |
| Input resistance                     | 100kΩ ±1%  |
| Resolution                           | 16-bit plus sign (as speed reference)  |
| Monotonic                            | Yes (including 0V)   |
| Dead band                            | None (including 0V)  |
| Jumps                                | None (including 0V)  |
| Maximum offset                       | 700µV  |
| Maximum non linearity                | 0.3% of input  |
| Maximum gain asymmetry               | 0.5%   |
| Input filter bandwidth single pole   | ~1kHz  |
| Sampling period                      | 250µs with destinations as Pr 1.36, Pr 1.37 or Pr 3.22 in closed loop vector or servo mode. 4ms for open loop mode and all other destinations in closed loop vector or servo mode. |

| 7 Analogue input 2                      |  |
|---|--|
| <b>Default function</b>                 | <b>Frequency/speed reference</b>   |
| Type of input                           | Bipolar single-ended analogue voltage or unipolar current  |
| Mode controlled by...                   | Pr 7.11  |
| <b>Operating in Voltage mode</b>        |  |
| Full scale voltage range                | ±9.8V ±3%  |
| Maximum offset                          | ±30mV  |
| Absolute maximum voltage range          | ±36V relative to 0V  |
| Input resistance                        | >100kΩ   |
| <b>Operating in current mode</b>        |  |
| Current ranges                          | 0 to 20mA ±5%, 20 to 0mA ±5%, 4 to 20mA ±5%, 20 to 4mA ±5%   |
| Maximum offset                          | 250µA  |
| Absolute maximum voltage (reverse bias) | -36V max   |
| Absolute maximum current                | +70mA  |
| Equivalent input resistance             | ≤200Ω at 20mA  |
| <b>Common to all modes</b>              |  |
| Resolution                              | 10 bit + sign  |
| Sample period                           | 250µs when configured as voltage input with destinations as Pr 1.36, Pr 1.37, Pr 3.22 or Pr 4.08 in closed loop vector or servo mode. 4ms for open loop mode, all other destinations in closed loop vector or servo mode, or any destination when configured as a current input. |

| 8 Analogue input 3                         |  |
|--|--|
| <b>Default function</b>                    | <b>V01.07.00 and later: Motor thermistor input (PTC)<br/>V01.06.02 and earlier: Not configured</b>   |
| Type of input                              | Bipolar single-ended analogue voltage, unipolar current or motor thermistor input  |
| Mode controlled by...                      | Pr 7.15  |
| <b>Operating in Voltage mode (default)</b> |  |
| Voltage range                              | ±9.8V ±3%  |
| Maximum offset                             | ±30mV  |
| Absolute maximum voltage range             | ±36V relative to 0V  |
| Input resistance                           | >100kΩ   |
| <b>Operating in current mode</b>           |  |
| Current ranges                             | 0 to 20mA ±5%, 20 to 0mA ±5%, 4 to 20mA ±5%, 20 to 4mA ±5%   |
| Maximum offset                             | 250µA  |
| Absolute maximum voltage (reverse bias)    | -36V max   |
| Absolute maximum current                   | +70mA  |
| Equivalent input resistance                | ≤200Ω at 20mA  |
| <b>Operating in thermistor input mode</b>  |  |
| Internal pull-up voltage                   | <5V  |
| Trip threshold resistance                  | 3.3kΩ ±10%   |
| Reset resistance                           | 1.8kΩ ±10%   |
| Short-circuit detection resistance         | 50Ω ±30%   |
| <b>Common to all modes</b>                 |  |
| Resolution                                 | 10 bit + sign  |
| Sample period                              | 250µs when configured as voltage input with destinations as Pr 1.36, Pr 1.37, Pr 3.22 or Pr 4.08 in closed loop vector or servo mode. 4ms for open loop mode, all other destinations in closed loop vector or servo mode, or any destination when configured as a current input. |

T8 analogue input 3 has a parallel connection to terminal 15 of the drive encoder connector.

| 9 Analogue output 1                        |  |
|--|--|
| 10 Analogue output 2                       |  |
| <b>Terminal 9 default function</b>         | <b>OL&gt; Motor FREQUENCY output signal<br/>CL&gt; SPEED output signal</b>   |
| <b>Terminal 10 default function</b>        | <b>Motor active current</b>  |
| Type of output                             | Bipolar single-ended analogue voltage or unipolar single ended current   |
| Mode controlled by...                      | Pr 7.21 and Pr 7.24  |
| <b>Operating in Voltage mode (default)</b> |  |
| Voltage range                              | ±9.6V ±5%  |
| Maximum offset                             | 100mV  |
| Maximum output current                     | ±10mA  |
| Load resistance                            | 1kΩ min  |
| Protection                                 | 35mA max. Short circuit protection   |
| <b>Operating in current mode</b>           |  |
| Current ranges                             | 0 to 20mA ±10%<br>4 to 20mA ±10%   |
| Maximum offset                             | 600µA  |
| Maximum open circuit voltage               | +15V   |
| Maximum load resistance                    | 500Ω   |
| <b>Common to all modes</b>                 |  |
| Resolution                                 | 10-bit (plus sign in voltage mode)   |
| Update period                              | 250µs when configured as a high speed output with sources as Pr 4.02, Pr 4.17 in all modes or Pr 3.02, Pr 5.03 in closed loop vector or servo mode. 4ms when configured as any other type of output or with all other sources. |

| 11 0V common    |   |
|-----------------|---|
| <b>Function</b> | <b>Common connection for all external devices</b> |

| 21 0V common    |   |
|-----------------|---|
| <b>Function</b> | <b>Common connection for all external devices</b> |

| 22 +24V user output (selectable)    |   |
|-------------------------------------|---|
| <b>Terminal 22 default function</b> | <b>+24V user output</b>   |
| Programmability                     | Can be switched on or off to act as a fourth digital output (positive logic only) by setting the source Pr 8.28 and source invert Pr 8.18 |
| Nominal output current              | 200mA (including all digital I/O)   |
| Maximum output current              | 240mA (including all digital I/O)   |
| Protection                          | Current limit and trip  |

| 23 0V common    |   |
|-----------------|---|
| <b>Function</b> | <b>Common connection for all external devices</b> |

information.

|  |  |
|--|--|
| <b>24</b>                              | <b>Digital I/O 1</b>   |
| <b>25</b>                              | <b>Digital I/O 2</b>   |
| <b>26</b>                              | <b>Digital I/O 3</b>   |
| <b>Terminal 24 default function</b>    | <b>AT ZERO SPEED output</b>  |
| <b>Terminal 25 default function</b>    | <b>DRIVE RESET input</b>   |
| <b>Terminal 26 default function</b>    | <b>RUN FORWARD input</b>   |
| Type                                   | Positive or negative logic digital inputs, or negative logic push-pull or open collector outputs   |
| Input / output mode controlled by...   | Pr 8.31, Pr 8.32 and Pr 8.33   |
| <b>Operating as an input</b>           |  |
| Logic mode controlled by...            | Pr 8.29  |
| Absolute maximum applied voltage range | ±30V   |
| Load                                   | <2mA @ 15Vdc   |
| Input thresholds                       | 10.0V ±0.8V  |
| <b>Operating as an output</b>          |  |
| Open collector outputs selected        | Pr 8.30  |
| Nominal maximum output current         | 200mA (total including terminal 22)  |
| Maximum output current                 | 240mA (total including terminal 22)  |
| <b>Common to all modes</b>             |  |
| Voltage range                          | 0V to +24V   |
| Sample / Update period                 | 250µs when configured as an input with destinations as Pr 6.35 or Pr 6.36. 4ms in all other cases. |

|  |  |
|--|--|
| <b>27</b>                              | <b>Digital Input 4</b>   |
| <b>28</b>                              | <b>Digital Input 5</b>   |
| <b>29</b>                              | <b>Digital Input 6</b>   |
| <b>Terminal 27 default function</b>    | <b>RUN REVERSE input</b>   |
| <b>Terminal 28 default function</b>    | <b>ANALOGUE INPUT 1 / INPUT 2 select</b>                               |
| <b>Terminal 29 default function</b>    | <b>JOG SELECT input</b>  |
| Type                                   | Negative or positive logic digital inputs                              |
| Logic mode controlled by...            | Pr 8.29  |
| Voltage range                          | 0V to +24V   |
| Absolute maximum applied voltage range | ±30V   |
| Load                                   | <2mA @ 15V   |
| Input thresholds                       | 10.0V ±0.8V  |
| Sample / Update period                 | 250µs with destinations as Pr 6.35 or Pr 6.36. 4ms in all other cases. |

|                 |   |
|-----------------|---|
| <b>30</b>       | <b>0V common</b>                                  |
| <b>Function</b> | <b>Common connection for all external devices</b> |

|   |  |
|---|--|
| <b>31</b>   | <b>Drive enable (SECURE DISABLE function)</b>                                |
| Type  | Positive logic only digital input  |
| Voltage range   | 0V to +24V   |
| Absolute maximum applied voltage  | ±30V   |
| Thresholds  | 18.5V ±0.5V  |
| Sample period   | Disabling the drive (hardware): <100µs<br>Enabling the drive (software): 4ms |
| The drive enable terminal (T31) provides a SECURE DISABLE function. The SECURE DISABLE function meets the requirements of EN954-1 category 3 for the prevention of unexpected starting of the drive. It may be used in a safety-related application in preventing the drive from generating torque in the motor to a high level of integrity. |  |

Refer to section 4.16 SECURE DISABLE on page 100 for further

|                                    |   |
|------------------------------------|---|
| <b>41</b>                          | <b>Relay contacts</b>   |
| <b>42</b>                          |   |
| <b>Default function</b>            | <b>Drive healthy indicator</b>  |
| Contact voltage rating             | 240Vac, Installation over-voltage category II                                     |
| Contact maximum current rating     | 2A AC 240V<br>4A DC 30V resistive load<br>0.5A DC 30V inductive load (L/R = 40ms) |
| Contact minimum recommended rating | 12V 100mA   |
| Contact type                       | Normally open   |
| Default contact condition          | Closed when power applied and drive healthy                                       |
| Update period                      | 4ms   |



**WARNING**

A fuse or other over-current protection should be fitted to the relay circuit.

## 4.14 Encoder connections

Figure 4-43 Location of encoder connector

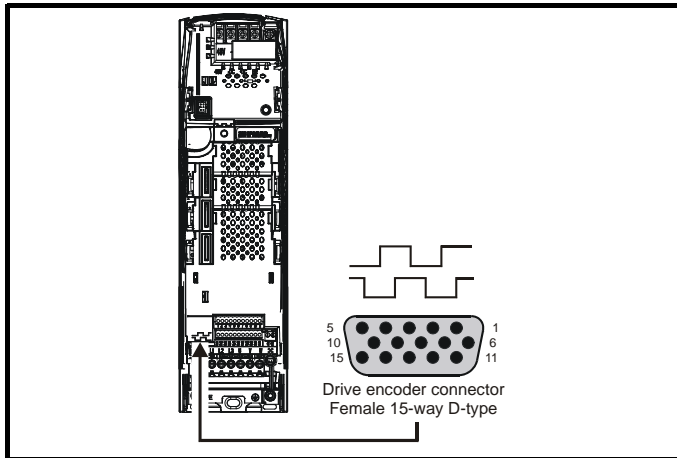


Table 4-19 Encoder types

| Setting of Pr 3.38     | Description   |
|------------------------|---|
| <b>Ab</b><br>(0)       | Quadrature incremental encoder with or without marker pulse   |
| <b>Fd</b><br>(1)       | Incremental encoder with frequency pulses and direction, with or without marker pulse   |
| <b>Fr</b><br>(2)       | Incremental encoder with forward pulses and reverse pulses, with or without marker pulse  |
| <b>Ab.SERVO</b><br>(3) | Quadrature incremental encoder with UVW commutation signals, with or without marker pulse<br>Encoder with UVW commutation signals only (Pr 3.34 set to zero)* |
| <b>Fd.SERVO</b><br>(4) | Incremental encoder with frequency pulses and direction with commutation signals**, with or without marker pulse  |
| <b>Fr.SERVO</b><br>(5) | Incremental encoder with forward pulses and reverse pulses with commutation signals**, with or without marker pulse   |
| <b>SC</b><br>(6)       | SinCos encoder without serial communications  |
| <b>SC.HiPER</b><br>(7) | Absolute SinCos encoder with HiperFace serial communications protocol (Stegmann)  |
| <b>EndAt</b><br>(8)    | Absolute EndAt serial communications encoder (Heidenhain)   |
| <b>SC.EndAt</b><br>(9) | Absolute SinCos encoder with EnDat serial communications protocol (Heidenhain)  |
| <b>SSI</b><br>(10)     | Absolute SSI only encoder   |
| <b>SC.SSI</b><br>(11)  | Absolute SinCos encoder with SSI  |

\* This feedback device provides very low resolution feedback and should not be used for applications requiring a high level of performance

\*\* The U, V & W commutation signals are required with an incremental type encoder when used with a servo motor. The UVW commutation signals are used to define the motor position during the first 120° electrical rotation after the drive is powered-up or the encoder is initialised.

**Table 4-20 Drive encoder connector details**

| Terminal | Setting of Pr 3.38              |        |        |              |              |              |                                 |                                      |           |              |          |             |
|----------|---------------------------------|--------|--------|--------------|--------------|--------------|---------------------------------|--------------------------------------|-----------|--------------|----------|-------------|
|          | Ab (0)                          | Fd (1) | Fr (2) | Ab.SErVO (3) | Fd.SErVO (4) | Fr.SErVO (5) | SC (6)                          | SC.HiPEr (7)                         | EndAt (8) | SC.EndAt (9) | SSI (10) | SC.SSI (11) |
| 1        | A                               | F      | F      | A            | F            | F            | Cos                             |                                      |           | Cos          |          | Cos         |
| 2        | A\                              | F\     | F\     | A\           | F\           | F\           | Cosref                          |                                      |           | Cosref       |          | Cosref      |
| 3        | B                               | D      | R      | B            | D            | R            | Sin                             |                                      |           | Sin          |          | Sin         |
| 4        | B\                              | D\     | R\     | B\           | D\           | R\           | Sinref                          |                                      |           | Sinref       |          | Sinref      |
| 5        | Z*                              |        |        |              |              |              |                                 | Encoder input - Data (input/output)  |           |              |          |             |
| 6        | Z\*                             |        |        |              |              |              |                                 | Encoder input - Data\ (input/output) |           |              |          |             |
| 7        | Simulated encoder Aout, Fout**  |        |        | U            |              |              | Simulated encoder Aout, Fout**  |                                      |           |              |          |             |
| 8        | Simulated encoder Aout\, Fout** |        |        | U\           |              |              | Simulated encoder Aout\, Fout** |                                      |           |              |          |             |
| 9        | Simulated encoder Bout, Dout**  |        |        | V            |              |              | Simulated encoder Bout, Dout**  |                                      |           |              |          |             |
| 10       | Simulated encoder Bout\, Dout** |        |        | V\           |              |              | Simulated encoder Bout\, Dout** |                                      |           |              |          |             |
| 11       |                                 |        |        | W            |              |              |                                 | Encoder input - Clock (output)       |           |              |          |             |
| 12       |                                 |        |        | W\           |              |              |                                 | Encoder input - Clock\ (output)      |           |              |          |             |
| 13       | +V***                           |        |        |              |              |              |                                 |                                      |           |              |          |             |
| 14       | 0V common                       |        |        |              |              |              |                                 |                                      |           |              |          |             |
| 15       | th****                          |        |        |              |              |              |                                 |                                      |           |              |          |             |

- \* Marker pulse is optional
- \*\* Simulated encoder output only available in open-loop
- \*\*\* The encoder supply is selectable through parameter configuration to 5Vdc, 8Vdc and 15Vdc
- \*\*\*\* Terminal 15 is a parallel connection to T8 analogue input 3. If this is to be used as a thermistor input, ensure that Pr 7.15 is set to 'th.sc' (7), 'th' (8) or 'th.diSP' (9).

**NOTE**

SSI encoders typically have maximum baud rate of 500kbaud. When a SSI only encoder is used for speed feedback with a closed loop vector or servo motor, a large speed feedback filter (Pr 3.42) is required due to the time taken for the position information to be transferred from the encoder into the drive. The addition of this filter means that SSI only encoders are not suitable for speed feedback in dynamic or high-speed applications.

#### 4.14.1 Specifications

##### Feedback device connections

Ab, Fd, Fr, Ab.SErVO, Fd.SErVO and Fr.SErVO encoders

|   |  |
|---|--|
| <b>1</b>  | <b>Channel A, Frequency or Forward inputs</b>                |
| <b>2</b>  | <b>Channel A, Frequency\ or Forward\ inputs</b>              |
| <b>3</b>  | <b>Channel B, Direction or Reverse inputs</b>                |
| <b>4</b>  | <b>Channel B, Direction\ or Reverse\ inputs</b>              |
| Type  | EIA 485 differential receivers                               |
| Maximum input frequency                         | V01.06.01 and later: 500kHz<br>V01.06.00 and earlier: 410kHz |
| Line loading                                    | <2 unit loads  |
| Line termination components                     | 120Ω (switchable)  |
| Working common mode range                       | +12V to -7V  |
| Absolute maximum applied voltage relative to 0V | ±25V   |
| Absolute maximum applied differential voltage   | ±25V   |

|   |   |
|---|---|
| <b>5</b>  | <b>Marker pulse channel Z</b>   |
| <b>6</b>  | <b>Marker pulse channel Z1</b>  |
| <b>7</b>  | <b>Phase channel U</b>  |
| <b>8</b>  | <b>Phase channel U1</b>   |
| <b>9</b>  | <b>Phase channel V</b>  |
| <b>10</b>                                       | <b>Phase channel V1</b>   |
| <b>11</b>                                       | <b>Phase channel W</b>  |
| <b>12</b>                                       | <b>Phase channel W1</b>   |
| Type  | EIA 485 differential receivers  |
| Maximum input frequency                         | 512kHz  |
| Line loading                                    | 32 unit loads (for terminals 5 and 6)<br>1 unit load (for terminals 7 to 12)        |
| Line termination components                     | 120Ω (switchable for terminals 5 and 6,<br>always in circuit for terminals 7 to 12) |
| Working common mode range                       | +12V to -7V   |
| Absolute maximum applied voltage relative to 0V | +14V to -9V   |
| Absolute maximum applied differential voltage   | +14V to -9V   |

##### SC, SC.HiPEr, EndAt, SC.EndAt, SSI and SC.SSI encoders

|          |                        |
|----------|------------------------|
| <b>1</b> | <b>Channel Cos*</b>    |
| <b>2</b> | <b>Channel Cosref*</b> |
| <b>3</b> | <b>Channel Sin*</b>    |
| <b>4</b> | <b>Channel Sinref*</b> |

|  |  |
|--|--|
| Type   | Differential voltage   |
| Maximum Signal level   | 1.25V peak to peak (sin with regard to sinref and cos with regard to cosref) |
| Maximum input frequency  | See Table 4-21   |
| Maximum applied differential voltage and common mode voltage range | ±4V  |

For the SinCos encoder to be compatible with Unidrive SP, the output signals from the encoder must be a 1V peak to peak differential voltage (across Sin to Sinref and Cos to Cosref).

The majority of encoders have a DC offset on all signals. Stegmann encoders typically have a 2.5Vdc offset. The Sinref and Cosref are a flat DC level at 2.5Vdc and the Cos and Sin signals have a 1V peak to peak waveform biased at 2.5Vdc.

Encoders are available which have a 1V peak to peak voltage on Sin, Sinref, Cos and Cosref. This results in a 2V peak to peak voltage seen at the drive's encoder terminals. It is not recommended that encoders of this type are used with Unidrive SP, and that the encoder feedback signals should meet the above parameters (1V peak to peak).

**Resolution:** The sinewave frequency can be up to 500kHz but the resolution is reduced at high frequency. Table 4-21 shows the number of bits of interpolated information at different frequencies and with different voltage levels at the drive encoder port. The total resolution in bits per revolution is the ELPR plus the number of bits of interpolated information. Although it is possible to obtain 11 bits of interpolation information, the nominal design value is 10 bits.

\* Not used with EndAt and SSI communications only encoders.

**Table 4-21 Feedback resolution based on frequency and voltage level**

| Volt/Freq | 1kHz | 5kHz | 50kHz | 100kHz | 200kHz | 500kHz |
|-----------|------|------|-------|--------|--------|--------|
| 1.2       | 11   | 11   | 10    | 10     | 9      | 8      |
| 1.0       | 11   | 11   | 10    | 9      | 9      | 7      |
| 0.8       | 10   | 10   | 10    | 9      | 8      | 7      |
| 0.6       | 10   | 10   | 9     | 9      | 8      | 7      |
| 0.4       | 9    | 9    | 9     | 8      | 7      | 6      |

|           |                  |
|-----------|------------------|
| <b>5</b>  | <b>Data**</b>    |
| <b>6</b>  | <b>Data1**</b>   |
| <b>11</b> | <b>Clock***</b>  |
| <b>12</b> | <b>Clock1***</b> |

|   |  |
|---|--|
| Type  | EIA 485 differential transceivers  |
| Maximum frequency                               | 2MHz   |
| Line loading                                    | 32 unit loads (for terminals 5 and 6)<br>1 unit load (for terminals 11 and 12) |
| Working common mode range                       | +12V to -7V  |
| Absolute maximum applied voltage relative to 0V | ±14V   |
| Absolute maximum applied differential voltage   | ±14V   |

\*\* Not used with SC encoders.

\*\*\* Not used with SC and SC.HiPEr encoders.

### Frequency slaving outputs (open loop only)

Ab, Fd, Fr, SC, SC.HiPEr, EndAt, SC.EndAt, SSI and SC.SSI encoders

|   |   |
|---|---|
| <b>7</b>  | <b>Frequency slaving out channel A</b>  |
| <b>8</b>  | <b>Frequency slaving out channel A\</b> |
| <b>9</b>  | <b>Frequency slaving out channel B</b>  |
| <b>10</b>                                       | <b>Frequency slaving out channel B\</b> |
| Type  | EIA 485 differential transceivers       |
| Maximum output frequency                        | 512kHz                                  |
| Absolute maximum applied voltage relative to 0V | ±14V                                    |
| Absolute maximum applied differential voltage   | ±14V                                    |

### Common to all Encoder types

|  |                                      |
|--|--------------------------------------|
| <b>13</b>  | <b>Encoder supply voltage</b>        |
| Supply voltage   | 5.15V ±2%, 8V ±5% or 15V ±5%         |
| Maximum output current   | 300mA for 5V and 8V<br>200mA for 15V |
| The voltage on terminal 13 is controlled by Pr 3.36. The default for this parameter is 5V (0) but this can be set to 8V (1) or 15V (2). Setting the encoder voltage supply too high for the encoder could result in damage to the feedback device. |                                      |
| If the 15V encoder supply is selected then the termination resistors must be disabled.   |                                      |
| The termination resistors should be disabled if the outputs from the encoder are higher than 5V.   |                                      |

|           |                  |
|-----------|------------------|
| <b>14</b> | <b>0V common</b> |
|-----------|------------------|

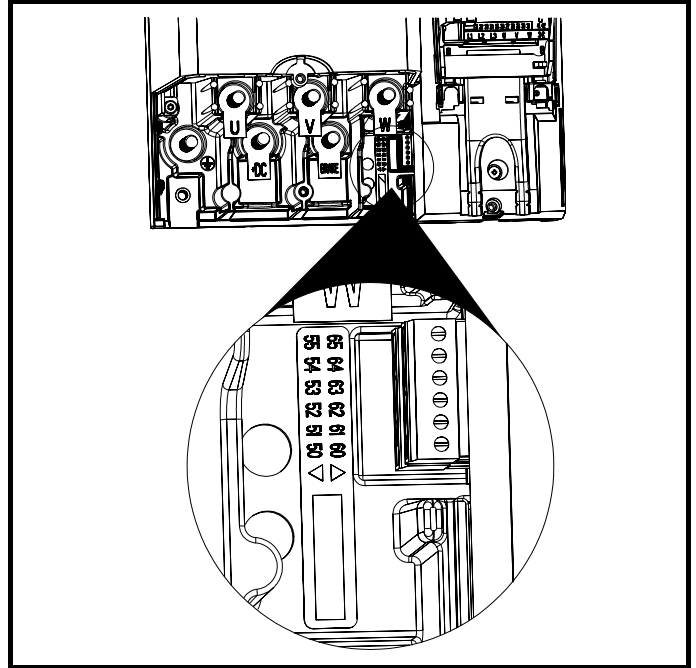
|  |                               |
|--|-------------------------------|
| <b>15</b>  | <b>Motor thermistor input</b> |
| This terminal is connected internally to terminal 8 of the signal connector. Connect only one of these terminals to a motor thermistor. Analogue input 3 must be in thermistor mode, Pr 7.15 = th.SC (7), th (8) or th.diSP (9). |                               |

## 4.15 Low voltage DC mode enable and heatsink fan supply connections (size 4 to 6)

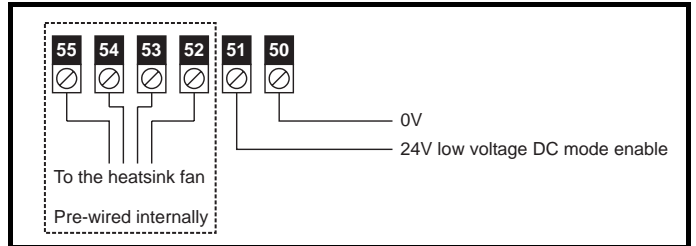
Unidrive SP sizes 4 to 6 require a 24V enable signal to terminal 50 and 51 of the lower terminal connector near the W phase output, to allow the drive to be used from a low voltage DC supply.

For more information regarding low voltage DC operation, see the *Low Voltage DC Mode Application Note*.

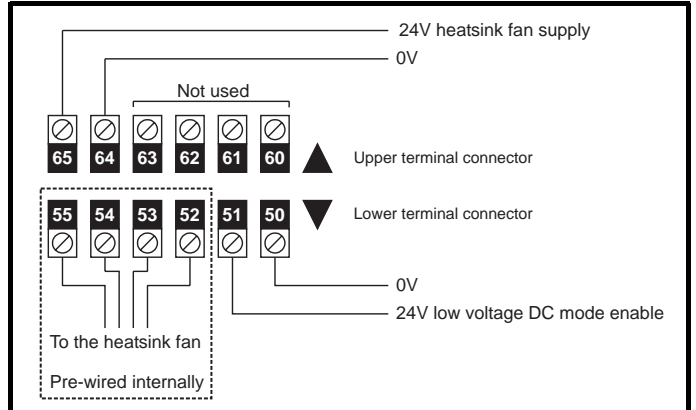
**Figure 4-44** Location of the size 4 to 6 low voltage DC mode enable connections



**Figure 4-45** Size 4 and 5 low voltage DC mode enable connections



**Figure 4-46** Size 6 low voltage DC mode enable connections



#### 4.15.1 Low voltage DC mode enable connections (sizes 4 to 6)

| 50                                   | 0V   |
|--------------------------------------|--|
| 51                                   | 24V low voltage DC mode enable                           |
| Function                             | To allow the drive it be used from low voltage DC supply |
| Nominal voltage                      | 24.0Vdc  |
| Minimum continuous operating voltage | 19.2Vdc  |
| Maximum continuous operating voltage | 30.0Vdc  |
| Nominal current consumption          | 500mA  |
| Recommended fuse                     | 8A 600V AC fast acting class CC type fuse                |

|                     |                          |
|---------------------|--------------------------|
| 52                  | Heatsink fan connections |
| 53                  |                          |
| 54                  |                          |
| 55                  |                          |
| No user connections |                          |

#### 4.15.2 Heatsink fan supply connections (size 6 only)

|                     |               |
|---------------------|---------------|
| 60                  | No connection |
| 61                  |               |
| 62                  |               |
| 63                  |               |
| No user connections |               |

| 64                                   | 0V  |
|--------------------------------------|---|
| 65                                   | 24V heatsink fan supply                                 |
| Function                             | To provide the power supply to the heatsink mounted fan |
| Nominal voltage                      | 24Vdc   |
| Minimum continuous operating voltage | 23.5V   |
| Maximum continuous operating voltage | 27V   |
| Current consumption                  | 3.3A  |
| Recommended power supply             | 24V, 100W, 4.5A   |
| Recommended fuse                     | 4A fast blow ( $I^2t$ less than $20A^2s$ )              |

#### 4.16 SECURE DISABLE

The Secure Disable (SD) function provides a means for preventing the drive from generating torque in the motor, with a very high level of integrity. It is suitable for incorporation into a safety system for a machine. It is also suitable for use as a conventional drive enable input.

The SD function makes use of the special property of an inverter drive with an induction motor, which is that torque cannot be generated without the continuous correct active behaviour of the inverter circuit. All credible faults in the inverter power circuit cause a loss of torque generation.

The SD function is fail-safe, so when the SD input is disconnected the drive will not operate the motor, even if a combination of components within the drive has failed. Most component failures are revealed by the drive failing to operate. SD is also independent of the drive firmware. This meets the requirements of EN954-1 category 3 for the prevention of operation of the motor.<sup>1</sup>


<sup>1</sup> Independent approval by BGIA has been given.


SD can be used to eliminate electro-mechanical contactors, including special safety contactors, which would otherwise be required for safety applications.


#### Note on the use of servo motors, other permanent-magnet motors, reluctance motors and salient-pole induction motors


When the drive is disabled through Secure Disable, a possible (although highly unlikely) failure mode is for two power devices in the inverter circuit to conduct incorrectly.

This fault cannot produce a steady rotating torque in any AC motor. It produces no torque in a conventional induction motor with a cage rotor. If the rotor has permanent magnets and/or saliency, then a transient alignment torque may occur. The motor may briefly try to rotate by up to 180° electrical, for a permanent magnet motor, or 90° electrical, for a salient pole induction motor or reluctance motor. This possible failure mode must be allowed for in the machine design.

|   |  |
|---|--|
| <br><b>WARNING</b> | The design of safety-related control systems must only be done by personnel with the required training and experience. The SD function will only ensure the safety of a machine if it is correctly incorporated into a complete safety system. The system must be subject to a risk assessment to confirm that the residual risk of an unsafe event is at an acceptable level for the application. |
|---|--|

|   |  |
|---|--|
| <br><b>WARNING</b> | To maintain category 3 according to EN954-1 the drive must be located inside an enclosure with degree of protection at least IP54. |
|---|--|

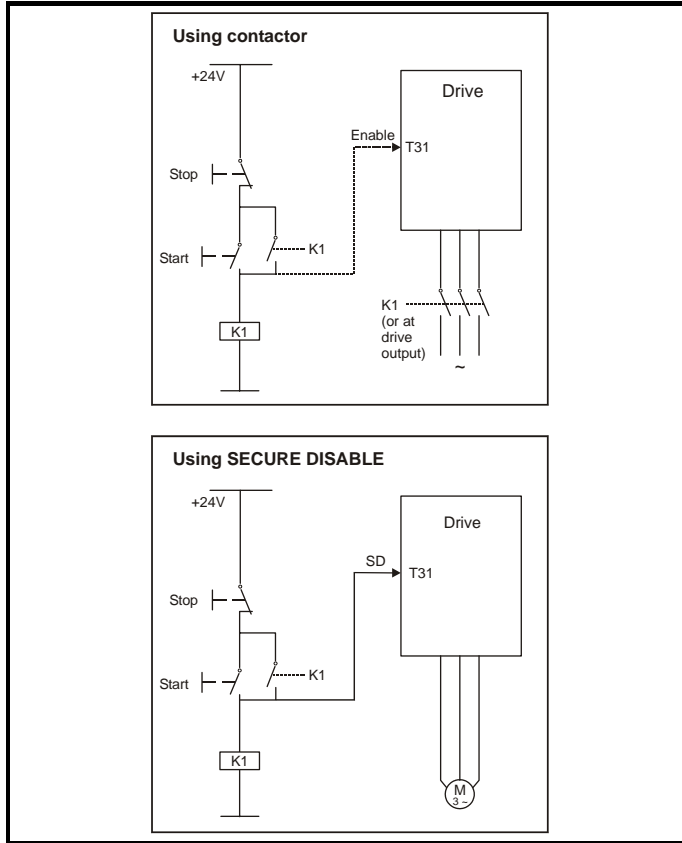
|   |  |
|---|--|
| <br><b>WARNING</b> | SD inhibits the operation of the drive, this includes inhibiting braking. If the drive is required to provide both braking and secure disable in the same operation (e.g. for emergency stop) then a safety timer relay or similar device must be used to ensure that the drive is disabled a suitable time after braking. The braking function in the drive is provided by an electronic circuit which is not fail-safe. If braking is a safety requirement, it must be supplemented by an independent fail-safe braking mechanism. |
|---|--|

|   |  |
|---|--|
| <br><b>WARNING</b> | SD does not provide electrical isolation. The supply to the drive must be disconnected by an approved isolation device before gaining access to power connections. |
|---|--|

The following diagrams illustrate how the SD input can be used to eliminate contactors and safety contactors from control systems. Please note these are provided for illustration only, every specific arrangement must be verified for suitability in the proposed application.

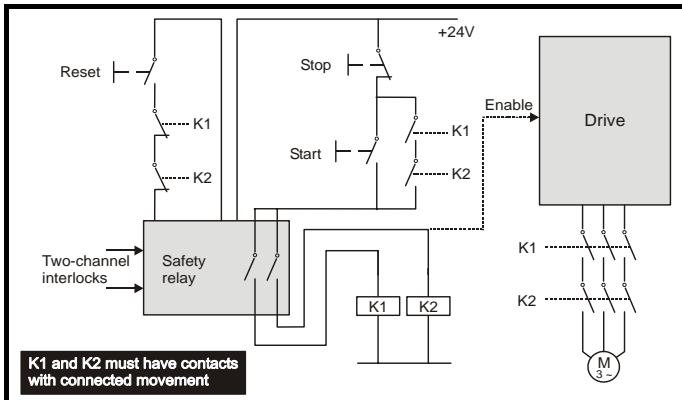
In the first example, illustrated in Figure 4-47, the SD function is used to replace a simple power contactor in applications where the risk of injury from unexpected starting is small, but it is not acceptable to rely on the complex hardware and firmware/software used by the stop/start function within the drive.

**Figure 4-47 Start / stop control EN954-1 category B - replacement of contactor**



In the second example, illustrated in Figure 4-48 and Figure 4-49, a conventional high-integrity system which uses two safety contactors with auxiliary contacts with connected movement is replaced by a single Secure Disable system. This arrangement meets EN954-1 category 3.

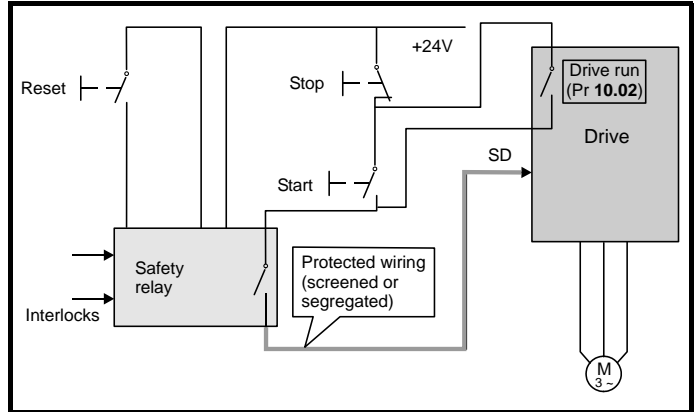
**Figure 4-48 Category 3 interlock using electromechanical safety contactors**



The safety function of the example circuit is to ensure that the motor does not operate when the interlocks are not signalling a safe state. The safety relay is used to check the two interlock channels and detect faults in those channels. The stop/start buttons are shown for completeness as part of a typical arrangement, they do not carry out a safety function and

are not necessary for the safe operation of the circuit.

**Figure 4-49 Category 3 interlock using Secure Disable with protected wiring**



In the conventional system, a contactor failure in the unsafe direction is detected the next time the safety relay is reset. Since the drive is not part of the safety system it has to be assumed that AC power is always available to drive the motor, so two contactors in series are required in order to prevent the first failure from causing an unsafe event (i.e. the motor driven).

With Secure Disable there are no single faults in the drive which can permit the motor to be driven. Therefore it is not necessary to have a second channel to interrupt the power connection, nor a fault detection circuit.

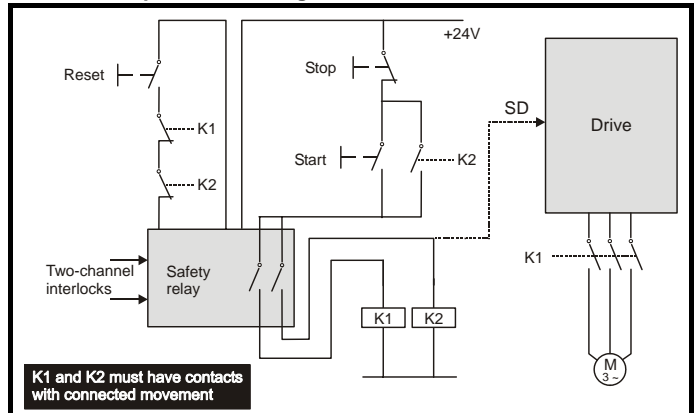
It is important to note that a single short-circuit from the Enable input (SD) to a DC supply of approximately +24V would cause the drive to be enabled. For this reason, Figure 4-49 shows the wire from the Enable input to the safety relay as "protected wiring" so that the possibility of a short circuit from this wire to the DC supply can be excluded, as specified in ISO 13849-2. The wiring can be protected by placing it in a segregated cable duct or other enclosure, or by providing it with a grounded shield. The shield is provided to avoid a hazard from an electrical fault. It may be grounded by any convenient method, no special EMC precautions are required.

If the use of protected wiring is not acceptable, so that the possibility of this short circuit must be allowed for, then a relay must be used to monitor the state of the Enable input, together with a single safety contactor to prevent operation of the motor after a fault. This is illustrated in Figure 4-50.

**NOTE**

The auxiliary relay K2 must be located in the same enclosure and close to the drive, with its coil connected as closely as possible to the drive enable (SD) input.

**Figure 4-50 Use of contactor and relay to avoid the need for protected wiring**



For further applications guidance, refer to the *Unidrive SP Advanced User Guide*.

## 5 Getting Started

This chapter introduces the user interfaces, menu structure and security level of the drive.

### 5.1 Understanding the display

There are two keypads available for the Unidrive SP. The SM-Keypad has an LED display and the SM-Keypad Plus has an LCD display. Both keypads can be fitted to the drive but the SM-Keypad Plus can also be remotely mounted on an enclosure door.

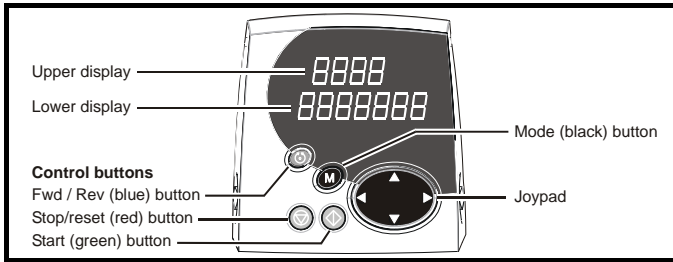
#### 5.1.1 SM-Keypad (LED)

The display consists of two horizontal rows of 7 segment LED displays.

The upper display shows the drive status or the current menu and parameter number being viewed.

The lower display shows the parameter value or the specific trip type.

Figure 5-1 SM-Keypad



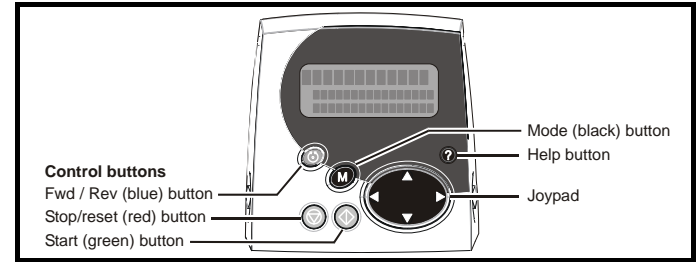
#### 5.1.2 SM-Keypad Plus (LCD)

The display consists of three lines of text.

The top line shows the drive status or the current menu and parameter number being viewed on the left, and the parameter value or the specific trip type on the right.

The lower two lines show the parameter name or the help text.

Figure 5-2 SM-Keypad Plus



**NOTE** The red stop button is also used to reset the drive.

Both the SM-Keypad and the SM-Keypad Plus can indicate when a SMARTCARD access is taking place or when the second motor map is active (menu 21). These are indicated on the displays as follows.

|                               | SM-Keypad   | SM-Keypad Plus   |
|-------------------------------|---|--|
| SMARTCARD access taking place | The decimal point after the fourth digit in the upper display will flash. | The symbol 'CC' will appear in the lower left hand corner of the display   |
| Second motor map active       | The decimal point after the third digit in the upper display will flash.  | The symbol 'Mot2' will appear in the lower left hand corner of the display |

### 5.2 Keypad operation

#### 5.2.1 Control buttons

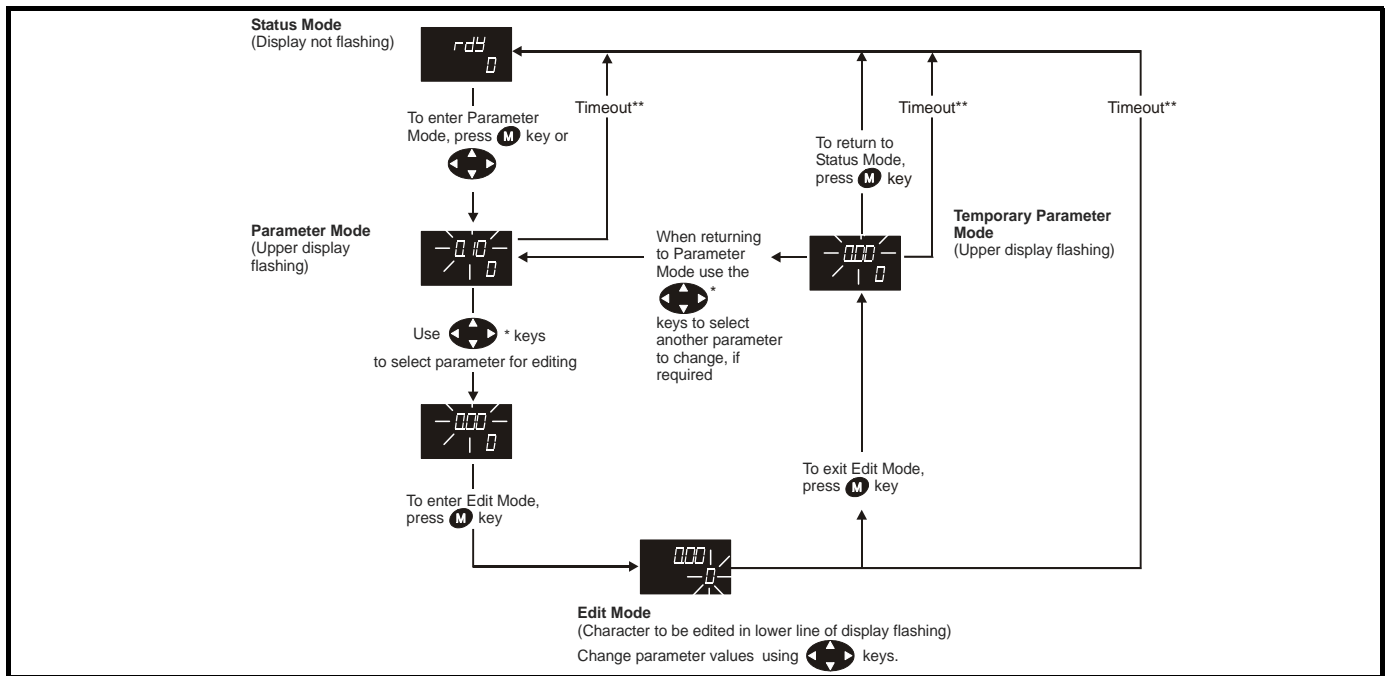
The keypad consists of:

1. Joypad - used to navigate the parameter structure and change parameter values.
2. Mode button - used to change between the display modes – parameter view, parameter edit, status.
3. Three control buttons - used to control the drive if keypad mode is selected.
4. Help button (SM-Keypad Plus only) - displays text briefly describing the selected parameter.

The Help button toggles between other display modes and parameter help mode. The up and down functions on the joypad scroll the help text to allow the whole string to be viewed. The right and left functions on the joypad have no function when help text is being viewed.

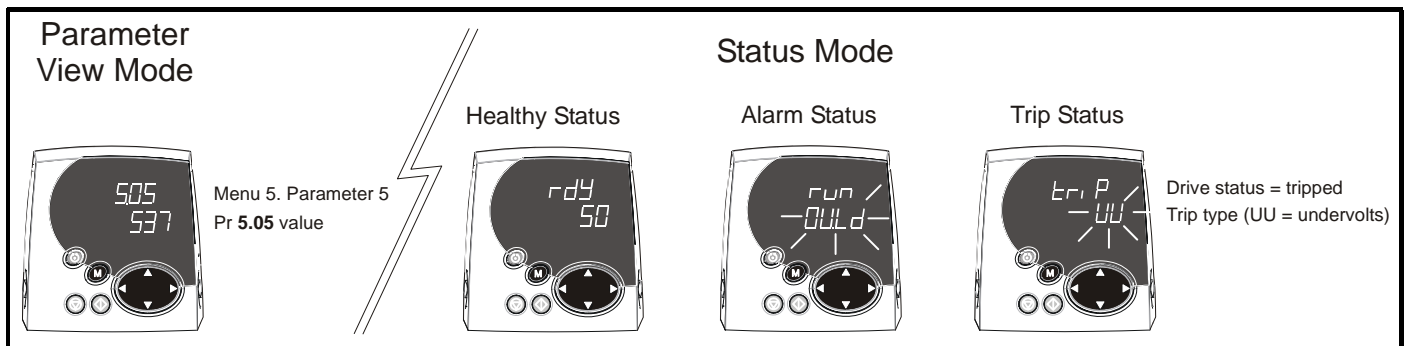
The display examples in this section show the SM-Keypad 7 segment LED display. The examples are the same for the SM-Keypad Plus except that the information displayed on the lower row on the SM-Keypad is displayed on the right hand side of the top row on the SM-Keypad Plus.

**Figure 5-3 Display modes**



\* can only be used to move between menus if L2 access has been enabled (Pr 0.49). Refer to section 5.9 on page 106.  
 \*\*Timeout defined by Pr 11.41 (default value = 240s).

**Figure 5-4 Mode examples**



**WARNING**  
Do not change parameter values without careful consideration; incorrect values may cause damage or a safety hazard.

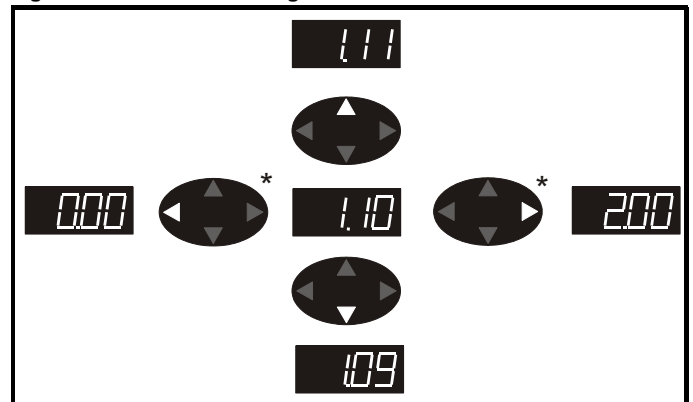
**NOTE**  
When changing the values of parameters, make a note of the new values in case they need to be entered again.

**NOTE**  
For new parameter-values to apply after the AC supply to the drive is interrupted, new values must be saved. Refer to section 5.7 *Saving parameters* on page 106.

### 5.3 Menu structure

The drive parameter structure consists of menus and parameters. The drive initially powers up so that only menu 0 can be viewed. The up and down arrow buttons are used to navigate between parameters and once level 2 access (L2) has been enabled (see Pr 0.49) the left and right buttons are used to navigate between menus. For further information, refer to section 5.9 *Parameter access level and security* on page 106.

**Figure 5-5 Parameter navigation**

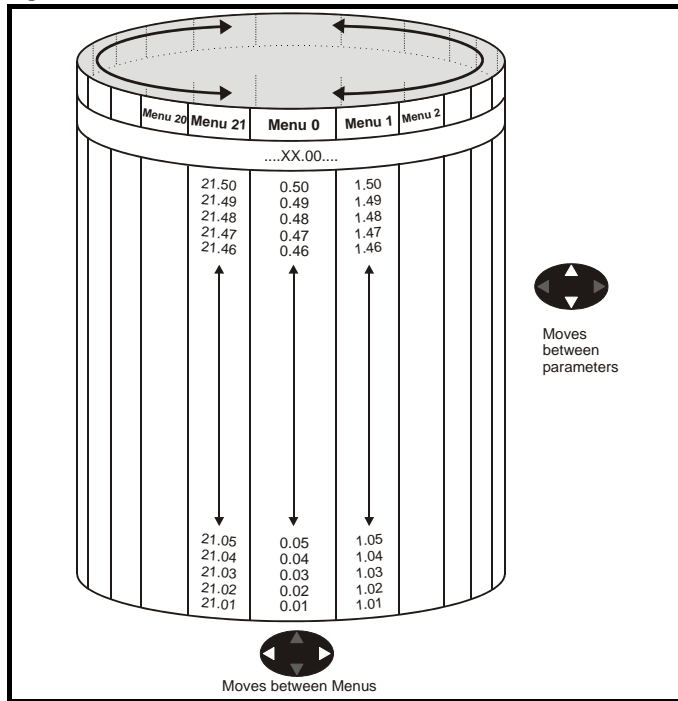


\* can only be used to move between menus if L2 access has been enabled (Pr 0.49). Refer to section 5.9 *Parameter access level and security* on page 106.

The menus and parameters roll over in both directions. i.e. if the last parameter is displayed, a further press will cause the display to rollover and show the first parameter.

When changing between menus the drive remembers which parameter was last viewed in a particular menu and thus displays that parameter.

Figure 5-6 Menu structure

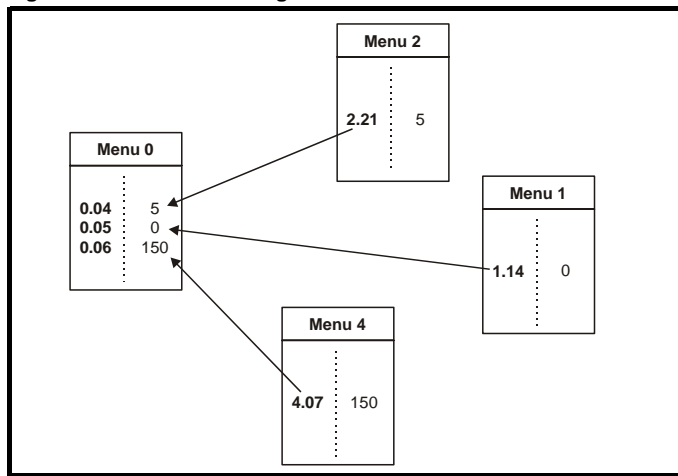


## 5.4 Menu 0

Menu 0 is used to bring together various commonly used parameters for basic easy set up of the drive. Appropriate parameters are cloned from the advanced menus into menu 0 and thus exist in both locations.

For further information, refer to Chapter 6 *Basic parameters (Menu 0)* on page 109.

Figure 5-7 Menu 0 Cloning



## 5.5 Advanced menus

The advanced menus consist of groups or parameters appropriate to a specific function or feature of the drive. Menus 0 to 22 can be viewed on both keypads. Menus 40 and 41 are specific to the SM-Keypad Plus (LCD). Menus 70 to 91 can be viewed with an SM-Keypad Plus (LCD) only when an SM-Applications is fitted.

| Menu       | Description  | LED | LCD |
|------------|--|-----|-----|
| 0          | Commonly used basic set up parameters for quick / easy programming | ✓   | ✓   |
| 1          | Frequency / speed reference  | ✓   | ✓   |
| 2          | Ramps  | ✓   | ✓   |
| 3          | Slave frequency, speed feedback and speed control                  | ✓   | ✓   |
| 4          | Torque and current control   | ✓   | ✓   |
| 5          | Motor control  | ✓   | ✓   |
| 6          | Sequencer and clock  | ✓   | ✓   |
| 7          | Analogue I/O   | ✓   | ✓   |
| 8          | Digital I/O  | ✓   | ✓   |
| 9          | Programmable logic, motorised pot and binary sum                   | ✓   | ✓   |
| 10         | Status and trips   | ✓   | ✓   |
| 11         | General drive set-up   | ✓   | ✓   |
| 12         | Threshold detectors and variable selectors                         | ✓   | ✓   |
| 13         | Position control   | ✓   | ✓   |
| 14         | User PID controller  | ✓   | ✓   |
| 15, 16, 17 | Solutions Module set-up  | ✓   | ✓   |
| 18         | Application menu 1   | ✓   | ✓   |
| 19         | Application menu 2   | ✓   | ✓   |
| 20         | Application menu 3   | ✓   | ✓   |
| 21         | Second motor parameters  | ✓   | ✓   |
| 22         | Additional Menu 0 set-up   | ✓   | ✓   |
| 40         | Keypad configuration menu  | X   | ✓   |
| 41         | User filter menu   | X   | ✓   |
| 70         | PLC registers  | X   | ✓   |
| 71         | PLC registers  | X   | ✓   |
| 72         | PLC registers  | X   | ✓   |
| 73         | PLC registers  | X   | ✓   |
| 74         | PLC registers  | X   | ✓   |
| 75         | PLC registers  | X   | ✓   |
| 85         | Timer function parameters  | X   | ✓   |
| 86         | Digital I/O parameters   | X   | ✓   |
| 88         | Status parameters  | X   | ✓   |
| 90         | General parameters   | X   | ✓   |
| 91         | Fast access parameters   | X   | ✓   |

### 5.5.1 SM-Keypad Plus set-up menus

| Pr    | Title                       | Description   |
|-------|-----------------------------|---|
| 40.00 | Zero parameter              | Same as every other zero parameter                              |
| 40.01 | Language select             | English, Custom, French, German, Spanish, Italian               |
| 40.02 | Keypad software revision    | Firmware revision (e.g. 40102 is revision 04.01.02) (read-only) |
| 40.03 | Save configuration to flash | Idle, Save, Restore, Defaults                                   |
| 40.04 | LCD contrast                | xxx = Contrast Setting (0 = minimum, 31 = maximum)              |
| 40.05 | SMARTCARD save/restore      | Idle, Save, Restore (not implemented)                           |
| 40.06 | Browsing filter             | Normal, Filter  |
| 40.07 | Keypad security code        | xxx = PIN number to enable/disable keypad security              |
| 40.08 | Enable string DB upload     | Disable, Enable   |
| 40.09 | Hardware key security code  | Range = 0 to 999 to match drive security code                   |
| 40.10 | Keypad serial address       | Needs to match drive serial address                             |
| 40.11 | Keypad memory size          | 4Mbit, 8Mbit (read-only)  |

| Pr             | Title                          | Description                                  |
|----------------|--------------------------------|--|
| 41.00          | Zero parameter                 | Same as every other zero parameter           |
| 41.01 to 41.20 | Browsing filter F01 to F20     | smmp = any parameter (slot, menu, parameter) |
| 41.21          | Browsing filter exit parameter | "Normal", "Filter"                           |

### 5.5.2 Display messages

The following tables indicate the various possible mnemonics which can be displayed by the drive and their meaning.

Trip types are not listed here but can be found in Chapter 6 *Basic parameters (Menu 0)* on page 109 if required.

**Table 5-1 Alarm indications**

| Lower display | Description   |
|---------------|---|
| <b>br.rS</b>  | Braking resistor overload   |
|               | Braking resistor I <sup>2</sup> t accumulator (Pr 10.37) in the drive has reached 75.0% of the value at which the drive will trip and the braking IGBT is active.   |
| <b>Hot</b>    | Heatsink or control board or inverter IGBT over temperature alarms are active   |
|               | <ul style="list-style-type: none"> <li>The drive heatsink temperature has reached a threshold and the drive will trip 'Oh2' if the temperature continues to rise (see the 'Oh2' trip).</li> </ul> or <ul style="list-style-type: none"> <li>The ambient temperature around the control PCB is approaching the over temperature threshold (see the 'O.Ctl' trip).</li> </ul> |
| <b>OVLd</b>   | Motor overload  |
|               | The motor I <sup>2</sup> t accumulator in the drive has reached 75% of the value at which the drive will be tripped and the load on the drive is >100%  |

**Table 5-2 Status indications**

| Upper display     | Description   | Drive output stage |
|-------------------|---|--------------------|
| <b>ACt</b>        | Regeneration mode active  | Enabled            |
|                   | The regen unit is enabled and synchronised to the supply.   |                    |
| <b>ACUU</b>       | AC Supply loss  | Enabled            |
|                   | The drive has detected that the AC supply has been lost and is attempting to maintain the DC bus voltage by decelerating the motor.                         |                    |
| <b>*Auto tunE</b> | Autotune in progress  | Enabled            |
|                   | The autotune procedure has been initialised. **Auto' and 'tunE' will flash alternatively on the display.  |                    |
| <b>dc</b>         | DC applied to the motor   | Enabled            |
|                   | The drive is applying DC injection braking.   |                    |
| <b>dEC</b>        | Decelerating  | Enabled            |
|                   | The drive is decelerating the motor.  |                    |
| <b>inh</b>        | Inhibit   | Disabled           |
|                   | The drive is inhibited and cannot be run. The drive enable signal is not applied to terminal 31 or Pr 6.15 is set to 0.                                     |                    |
| <b>PLC</b>        | Onboard PLC program is running  | Not applicable     |
|                   | An Onboard PLC program is fitted and running. The lower display will flash 'PLC' once every 10s.  |                    |
| <b>POS</b>        | Positioning   | Enabled            |
|                   | The drive is positioning/orientating the motor shaft.   |                    |
| <b>rdY</b>        | Ready   | Disabled           |
|                   | The drive is ready to be run.   |                    |
| <b>run</b>        | Running   | Enabled            |
|                   | The drive is running.   |                    |
| <b>SCAN</b>       | Scanning  | Enabled            |
|                   | OL> The drive is searching for the motor frequency when synchronising to a spinning motor.<br>Regen> The drive is enabled and is synchronising to the line. |                    |
| <b>StoP</b>       | Stop or holding zero speed  | Enabled            |
|                   | The drive is holding zero speed.<br>Regen> The drive is enabled but the AC voltage is too low, or the DC bus voltage is still rising or falling.            |                    |
| <b>triP</b>       | Trip condition  | Disabled           |
|                   | The drive has tripped and is no longer controlling the motor. The trip code appears on the lower display.   |                    |

**Table 5-3 Solutions Module and SMARTCARD status indications on power-up**

| Lower display  | Description  |
|----------------|--|
| <b>boot</b>    | A parameter set is being transferred from the SMARTCARD to the drive during power-up. For further information, please refer to section 9.2.4 <i>Booting up from the SMARTCARD on every power up (Pr 11.42 = boot (4))</i> on page 153. |
| <b>cArD</b>    | The drive is writing a parameter set to the SMARTCARD during power-up. For further information, please refer to section 9.2.3 <i>Auto saving parameter changes (Pr 11.42 = Auto (3))</i> on page 153.                                  |
| <b>loAding</b> | The drive is writing information to a Solutions Module.  |

## 5.6 Changing the operating mode

Changing the operating mode returns all parameters to their default value, including the motor parameters. (Pr 0.49 *Security status* and Pr 0.34 *User security code* are not affected by this procedure.)

### Procedure

Use the following procedure only if a different operating mode is required:

1. Ensure the drive is not enabled, i.e. terminal 31 is open or Pr 6.15 is Off (0)
2. Enter either of the following values in Pr 0.00, as appropriate: 1253 (Europe, 50Hz AC supply frequency) 1254 (USA, 60Hz AC supply frequency)
3. Change the setting of Pr 0.48 as follows:

| 0.48 setting | Operating mode   |
|--------------|--|
|              | 1 Open-loop  |
|              | 2 Closed-loop Vector   |
|              | 3 Closed-loop Servo  |
|              | 4 Regen (See the Unidrive SP Regen Installation Guide for more information about operating in this mode) |

The figures in the second column apply when serial communications are used.

4. Either:
  - Press the red reset button
  - Toggle the reset digital input
  - Carry out a drive reset through serial communications by setting Pr 10.38 to 100 (ensure that Pr. xx.00 returns to 0).

## 5.7 Saving parameters

When changing a parameter in Menu 0, the new value is saved when pressing the Mode button to return to parameter view mode from parameter edit mode.

If parameters have been changed in the advanced menus, then the change will not be saved automatically. A save function must be carried out.

### Procedure

Enter 1000\* in Pr. xx.00

Either:

- Press the red reset button
- Toggle the reset digital input
- Carry out a drive reset through serial communications by setting Pr 10.38 to 100 (ensure that Pr. xx.00 returns to 0).

\*If the drive is in the under voltage trip state or is being supplied from a low voltage DC supply, a value of 1001 must be entered into Pr xx.00 to perform a save function.

## 5.8 Restoring parameter defaults

Restoring parameter defaults by this method saves the default values in the drive's memory. (Pr 0.49 and Pr 0.34 are not affected by this procedure.)

### Procedure

1. Ensure the drive is not enabled, i.e. terminal 31 is open or Pr 6.15 is Off (0)
2. Enter 1233 (EUR 50Hz settings) or 1244 (USA 60Hz settings) in Pr xx.00.
3. Either:
  - Press the red reset button
  - Toggle the reset digital input
  - Carry out a drive reset through serial communications by setting Pr 10.38 to 100 (ensure that Pr. xx.00 returns to 0).

## 5.9 Parameter access level and security

The parameter access level determines whether the user has access to menu 0 only or to all the advanced menus (menus 1 to 21) in addition to menu 0.

The User Security determines whether the access to the user is read only or read write.

Both the User Security and Parameter Access Level can operate independently of each other as shown in the table below:

| Parameter Access Level | User Security | Menu 0 status | Advanced menus status |
|------------------------|---------------|---------------|-----------------------|
| L1                     | Open          | RW            | Not visible           |
| L1                     | Closed        | RO            | Not visible           |
| L2                     | Open          | RW            | RW                    |
| L2                     | Closed        | RO            | RO                    |

RW = Read / write access RO = Read only access

The default settings of the drive are Parameter Access Level L1 and user Security Open, i.e. read / write access to Menu 0 with the advanced menus not visible.

### 5.9.1 Access Level

The access level is set in Pr 0.49 and allows or prevents access to the advanced menu parameters.

**L1 access selected** - Menu 0 only visible

|         |  |  |  |
|---------|--|--|--|
| Pr 0.00 |  |  |  |
| Pr 0.01 |  |  |  |
| Pr 0.02 |  |  |  |
| Pr 0.03 |  |  |  |
|         |  |  |  |
|         |  |  |  |
| Pr 0.49 |  |  |  |
| Pr 0.50 |  |  |  |

**L2 access selected** - All parameters visible

|         |         |       |          |          |
|---------|---------|-------|----------|----------|
|         |         |       |          |          |
|         |         |       |          |          |
|         |         |       |          |          |
|         |         |       |          |          |
|         |         |       |          |          |
|         |         |       |          |          |
|         |         |       |          |          |
|         |         |       |          |          |
| Pr 0.00 | Pr 1.00 | ..... | Pr 20.00 | Pr 21.00 |
| Pr 0.01 | Pr 1.01 | ..... | Pr 20.01 | Pr 21.01 |
| Pr 0.02 | Pr 1.02 | ..... | Pr 20.02 | Pr 21.02 |
| Pr 0.03 | Pr 1.03 | ..... | Pr 20.03 | Pr 21.03 |
|         |         | ..... |          |          |
|         |         | ..... |          |          |
| Pr 0.49 | Pr 1.49 | ..... | Pr 20.49 | Pr 21.49 |
| Pr 0.50 | Pr 1.50 | ..... | Pr 20.50 | Pr 21.50 |

### 5.9.2 Changing the Access Level

The Access Level is determined by the setting of Pr 0.49 as follows:

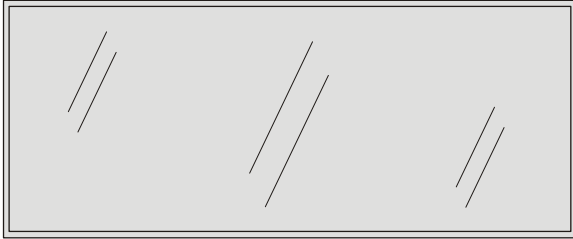
| String | Value | Effect                                  |
|--------|-------|---|
| L1     | 0     | Access to menu 0 only                   |
| L2     | 1     | Access to all menus (menu 0 to menu 21) |

The Access Level can be changed through the keypad even if the User Security has been set.

### 5.9.3 User Security

The User Security, when set, prevents write access to any of the parameters (other than Pr. 0.49 and Pr 11.44 Access Level) in any menu.

**User security open** - All parameters: Read / Write access



|         |         |       |          |          |
|---------|---------|-------|----------|----------|
| Pr 0.00 | Pr 1.00 | ..... | Pr 20.00 | Pr 21.00 |
| Pr 0.01 | Pr 1.01 | ..... | Pr 20.01 | Pr 21.01 |
| Pr 0.02 | Pr 1.02 | ..... | Pr 20.02 | Pr 21.02 |
| Pr 0.03 | Pr 1.03 | ..... | Pr 20.03 | Pr 21.03 |
|         |         | ..... |          |          |
|         |         | ..... |          |          |
| Pr 0.49 | Pr 1.49 | ..... | Pr 20.49 | Pr 21.49 |
| Pr 0.50 | Pr 1.50 | ..... | Pr 20.50 | Pr 21.50 |

**User security closed** - All parameters: Read Only access (except Pr 0.49 and Pr 11.44)

|         |         |       |          |          |
|---------|---------|-------|----------|----------|
| Pr 0.00 | Pr 1.00 | ..... | Pr 20.00 | Pr 21.00 |
| Pr 0.01 | Pr 1.01 | ..... | Pr 20.01 | Pr 21.01 |
| Pr 0.02 | Pr 1.02 | ..... | Pr 20.02 | Pr 21.02 |
| Pr 0.03 | Pr 1.03 | ..... | Pr 20.03 | Pr 21.03 |
|         |         | ..... |          |          |
|         |         | ..... |          |          |
| Pr 0.49 | Pr 1.49 | ..... | Pr 20.49 | Pr 21.49 |
| Pr 0.50 | Pr 1.50 | ..... | Pr 20.50 | Pr 21.50 |

### Setting User Security

Enter a value between 1 and 999 in Pr 0.34 and press the **M** button; the security code has now been set to this value. In order to activate the security, the Access level must be set to Loc in Pr 0.49. When the drive is reset, the security code will have been activated and the drive returns to Access Level L1. The value of Pr 0.34 will return to 0 in order to hide the security code. At this point, the only parameter that can be changed by the user is the Access Level Pr 0.49.

### Unlocking User Security

Select a read write parameter to be edited and press the **M** button, the upper display will now show CodE. Use the arrow buttons to set the security code and press the **M** button.

With the correct security code entered, the display will revert to the parameter selected in edit mode.

If an incorrect security code is entered the display will revert to parameter view mode.

To lock the User Security again, set Pr 0.49 to Loc and press the **↻** reset button.

### Disabling User Security.

Unlock the previously set security code as detailed above. Set Pr 0.34 to 0 and press the **M** button. The User Security has now been disabled, and will not have to be unlocked each time the drive is powered up to allow read / write access to the parameters.

### 5.10 Displaying parameters with non-default values only

By entering 12000 in Pr xx.00, the only parameters that will be visible to the user will be those containing a non-default value. This function does not require a drive reset to become active. In order to deactivate this function, return to Pr xx.00 and enter a value of 0.

Please note that this function can be affected by the access level enabled, refer to section 5.9 *Parameter access level and security* for further information regarding access level.

### 5.11 Displaying destination parameters only

By entering 12001 in Pr xx.00, the only parameters that will be visible to the user will be destination parameters. This function does not require a drive reset to become active. In order to deactivate this function, return to Pr xx.00 and enter a value of 0.

Please note that this function can be affected by the access level enabled, refer to section 5.9 *Parameter access level and security* for further information regarding access level.

### 5.12 Serial communications

#### 5.12.1 Introduction

The Unidrive SP has a standard 2-wire EIA485 interface (serial communications interface) which enables all drive set-up, operation and monitoring to be carried out with a PC or PLC if required. Therefore, it is possible to control the drive entirely by serial communications without the need for a SM-keypad or other control cabling. The drive supports two protocols selected by parameter configuration:

- Modbus RTU
- CT ANSI

Modbus RTU has been set as the default protocol, as it is used with the PC-tools commissioning software as provided on the CD ROM.

The serial communications port of the drive is a RJ45 socket, which is isolated from the power stage and the other control terminals (see section 4.12 *Serial communications connections* on page 91 for connection and isolation details).

The communications port applies a 2 unit load to the communications network.

#### 5.12.2 Serial communications set-up parameters

An external EIA232 hardware interface such as a PC cannot be used directly with the 2-wire EIA485 interface of the drive. Therefore a suitable converter is required.

A suitable EIA232 to EIA485 converter is the Control Techniques isolated CT Comms cable (CT Part No. 4500-0087)

When using the above converter or any other suitable converter with the Unidrive SP, it is recommended that no terminating resistors be connected on the network. It may be necessary to 'link out' the terminating resistor within the converter depending on which type is used. The information on how to link out the terminating resistor will normally be contained in the user information supplied with the converter.

#### 5.12.2 Serial communications set-up parameters

The following parameters need to be set according to the system requirements.

|                     |     |                     |           |
|---------------------|-----|---------------------|-----------|
| <b>0.35 {11.24}</b> |     | <b>Serial mode</b>  |           |
| RW                  | Txt |                     | US        |
| ↕                   |     | AnSI (0)<br>rtU (1) | ⇒ rtU (1) |

This parameter defines the communications protocol used by the 485 comms port on the drive. This parameter can be changed via the drive keypad, via a Solutions Module or via the comms interface itself. If it is changed via the comms interface, the response to the command uses

the original protocol. The master should wait at least 20ms before send a new message using the new protocol. (Note: ANSI uses 7 data bits, 1 stop bit and even parity; Modbus RTU uses 8 data bits, 2 stops bits and no parity.)

| Comms value | String | Communications mode                                  |
|-------------|--------|--|
| 0           | AnSI   | ANSI   |
| 1           | rTU    | Modbus RTU protocol                                  |
| 2           | Lcd    | Modbus RTU protocol, but with an SM-Keypad Plus only |

#### ANSI3.28 protocol

Full details of the CT ANSI communications protocol are the *Unidrive SP Advanced User Guide*.

#### Modbus RTU protocol

Full details of the CT implementation of Modbus RTU are given in the *Unidrive SP Advanced User Guide*.

#### Modbus RTU protocol, but with an SM-Keypad Plus only

This setting is used for disabling communications access when the SM-Keypad Plus is used as a hardware key. See the *Unidrive SP Advanced User Guide* for more details.

| 0.36 {11.25} Serial communications baud rate |   |
|--|---|
| RW   | Txt   |
| ↕  | 300 (0), 600 (1), 1200 (2), 2400 (3), 4800 (4), 9600 (5), 19200 (6), 38400 (7), 57600 (8)*, 115200 (9)* ⇒ 19200 (6) |

\* only applicable to Modbus RTU mode

This parameter can be changed via the drive keypad, via a Solutions Module or via the comms interface itself. If it is changed via the comms interface, the response to the command uses the original baud rate. The master should wait at least 20ms before send a new message using the new baud rate.

#### NOTE

When using the CT Comms cable the available baud rate is limited to 19.2k baud.

| 0.37 {11.23} Serial communications address |              |
|--|--------------|
| RW   | Txt          |
| ↕  | 0 to 247 ⇒ 1 |

Used to define the unique address for the drive for the serial interface. The drive is always a slave.

#### Modbus RTU

When the Modbus RTU protocol is used addresses between 0 and 247 are permitted. Address 0 is used to globally address all slaves, and so this address should not be set in this parameter

#### ANSI

When the ANSI protocol is used the first digit is the group and the second digit is the address within a group. The maximum permitted group number is 9 and the maximum permitted address within a group is 9. Therefore, Pr **0.37** is limited to 99 in this mode. The value 00 is used to globally address all slaves on the system, and x0 is used to address all slaves of group x, therefore these addresses should not be set in this parameter.

## 6 Basic parameters (Menu 0)

Menu 0 is used to bring together various commonly used parameters for basic easy set up of the drive. All the parameters in menu 0 appear in other menus in the drive (denoted by {...}).

Menus 11 and 22 can be used to change most of the parameters in menu 0. Menu 0 can also contain up to 59 parameters by setting up menu 22.

### 6.1 Single line descriptions

| Parameter                                | Range(⇅)                                   |  |  | Default(⇔) |  |                             | Type    |    |     |    |    |    |    |
|--|--|--|--|------------|--|-----------------------------|---------|----|-----|----|----|----|----|
|  | OL   | VT   | SV   | OL         | VT   | SV                          |         |    |     |    |    |    |    |
| <b>0.00</b> xx.00                        | {x.00}                                     | 0 to 32,767  |  |            | 0  |                             |         | RW | Uni |    |    |    |    |
| <b>0.01</b> Minimum reference clamp      | {1.07}                                     | ±3,000.0Hz   | ±SPEED_LIMIT_MAX Hz/rpm  |            | 0.0  |                             |         | RW | Bi  |    |    | PT | US |
| <b>0.02</b> Maximum reference clamp      | {1.06}                                     | 0 to 3,000.0Hz   | SPEED_LIMIT_MAX Hz/rpm   |            | EUR> 50.0<br>USA> 60.0                             | EUR> 1,500.0<br>USA> 1800.0 | 3,000.0 | RW | Uni |    |    |    | US |
| <b>0.03</b> Acceleration rate            | {2.11}                                     | 0.0 to 3,200.0<br>s/100Hz  | 0.000 to 3,200.000<br>s/1,000rpm                                     |            | 5.0  | 2.000                       | 0.200   | RW | Uni |    |    |    | US |
| <b>0.04</b> Deceleration rate            | {2.21}                                     | 0.0 to 3,200.0<br>s/100Hz  | 0.000 to 3,200.000<br>s/1,000rpm                                     |            | 10.0   | 2.000                       | 0.200   | RW | Uni |    |    |    | US |
| <b>0.05</b> Reference select             | {1.14}                                     | A1.A2 (0), A1.Pr (1), A2.Pr (2), Pr (3), PAd (4), Prc (5)  |  |            | A1.A2 (0)  |                             |         | RW | Txt |    | NC |    | US |
| <b>0.06</b> Current limit                | {4.07}                                     | 0 to Current_limit_max %   |  |            | 165.0  | 175.0                       |         | RW | Uni |    | RA |    | US |
| <b>0.07</b>                              | OL> Voltage mode select                    | {5.14}   | Ur_S (0),<br>Ur (1), Fd (2),<br>Ur_Auto (3),<br>Ur_I (4),<br>SrE (5) |            | Ur_I (4)   |                             |         | RW | Txt |    |    |    | US |
|  | CL> Speed controller P gain                | {3.10}   |  |            | 0.0100   |                             |         | RW | Uni |    |    |    | US |
| <b>0.08</b>                              | OL> Voltage boost                          | {5.15}   | 0.0 to 25.0%<br>of motor rated<br>voltage                            |            | Size 1 to 3: 3.0<br>Size 4 & 5: 2.0<br>Size 6: 1.0 |                             |         | RW | Uni |    |    |    | US |
|  | CL> Speed controller I gain                | {3.11}   | 0.00 to 655.35 1/rad   |            | 1.00   |                             |         | RW | Uni |    |    |    | US |
| <b>0.09</b>                              | OL> Dynamic V/F                            | {5.13}   | OFF (0) or On<br>(1)   |            | 0  |                             |         | RW | Bit |    |    |    | US |
|  | CL> Speed controller D gain                | {3.12}   | 0.00000 to 0.65535 (s)   |            | 0.00000  |                             |         | RW | Uni |    |    |    | US |
| <b>0.10</b>                              | OL> Estimated motor speed                  | {5.04}   | ±180,000 rpm   |            |  |                             |         | RO | Bi  | FI | NC | PT |    |
|  | CL> Motor speed                            | {3.02}   | ±Speed_max rpm   |            |  |                             |         | RO | Bi  | FI | NC | PT |    |
| <b>0.11</b>                              | OL & VT> Drive output<br>frequency         | {5.01}   | ±Speed_freq_max Hz   |            |  |                             |         | RO | Bi  | FI | NC | PT |    |
|  | SV> Drive encoder position                 | {3.29}   | 0 to 65,535<br>1/2 <sup>16</sup> ths of a<br>revolution              |            |  |                             |         | RO | Uni | FI | NC | PT |    |
| <b>0.12</b> Total motor current          | {4.01}                                     | 0 to Drive_current_max A   |  |            |  |                             |         | RO | Uni | FI | NC | PT |    |
| <b>0.13</b>                              | OL & VT> Motor active<br>current           | {4.02}   | ±Drive_current_max A   |            |  |                             |         | RO | Bi  | FI | NC | PT |    |
|  | SV> Analogue input 1 offset trim           | {7.07}   | ±10.000 %  |            | 0.000  |                             |         | RW | Bi  |    |    |    | US |
| <b>0.14</b> Torque mode selector         | {4.11}                                     | 0 to 1   | 0 to 4   |            | Speed control mode (0)                             |                             |         | RW | Uni |    |    |    | US |
| <b>0.15</b> Ramp mode select             | {2.04}                                     | FASt (0)<br>Std (1)<br>Std.hV (2)  | FASt (0)<br>Std (1)  |            | Std (1)  |                             |         | RW | Txt |    |    |    | US |
| <b>0.16</b>                              | OL> T28 and T29 auto-<br>selection disable | {8.39}   | OFF (0) or On<br>(1)   |            | 0  |                             |         | RW | Bit |    |    |    | US |
|  | CL> Ramp enable                            | {2.02}   | OFF (0) or On (1)  |            | On (1)   |                             |         | RW | Bit |    |    |    | US |
| <b>0.17</b>                              | OL> T29 digital input<br>destination       | {8.26}   | Pr 0.00 to<br>Pr 21.51   |            | Pr 6.31  |                             |         | RW | Uni | DE |    | PT | US |
|  | CL> Current demand filter<br>time constant | {4.12}   | 0.0 to 25.0 ms   |            | 0.0  |                             |         | RW | Uni |    |    |    | US |
| <b>0.18</b> Positive logic select        | {8.29}                                     | OFF (0) or On (1)  |  |            | On (1)   |                             |         | RW | Bit |    |    | PT | US |
| <b>0.19</b> Analogue input 2 mode        | {7.11}                                     | 0-20 (0), 20-0 (1), 4-20tr (2), 20-4tr (3),<br>4-20 (4), 20-4 (5), VOLt (6)                                    |  |            | VOLt (6)   |                             |         | RW | Txt |    |    |    | US |
| <b>0.20</b> Analogue input 2 destination | {7.14}                                     | Pr 0.00 to Pr 21.51  |  |            | Pr 1.37  |                             |         | RW | Uni | DE |    | PT | US |
| <b>0.21</b> Analogue input 3 mode        | {7.15}                                     | 0-20 (0), 20-0 (1), 4-20tr (2), 20-4tr (3),<br>4-20 (4), 20-4 (5), VOLt (6), th.SC (7),<br>th (8), th.diSp (9) |  |            | th (8)   |                             |         | RW | Txt |    |    | PT | US |
| <b>0.22</b> Bipolar reference select     | {1.10}                                     | OFF (0) or On (1)  |  |            | OFF (0)  |                             |         | RW | Bit |    |    |    | US |
| <b>0.23</b> Jog reference                | {1.05}                                     | 0 to 400.0 Hz  | 0 to 4000.0 rpm  |            | 0.0  |                             |         | RW | Uni |    |    |    | US |
| <b>0.24</b> Pre-set reference 1          | {1.21}                                     | ±Speed_limit_max rpm   |  |            | 0.0  |                             |         | RW | Bi  |    |    |    | US |
| <b>0.25</b> Pre-set reference 2          | {1.22}                                     | ±Speed_limit_max rpm   |  |            | 0.0  |                             |         | RW | Bi  |    |    |    | US |
| <b>0.26</b>                              | OL> Pre-set reference 3                    | {1.23}   | ±Speed_freq_max Hz/rpm   |            | 0.0  |                             |         | RW | Bi  |    |    |    | US |
|  | CL> Overspeed threshold                    | {3.08}   | 0 to 40,000 rpm  |            | 0  |                             |         | RW | Uni |    |    |    | US |
| <b>0.27</b>                              | OL> Pre-set reference 4                    | {1.24}   | ±Speed_freq_max Hz/rpm   |            | 0.0  |                             |         | RW | Bi  |    |    |    | US |
|  | CL> Drive encoder lines per<br>revolution  | {3.34}   | 0 to 50,000  |            | 1024 4096  |                             |         | RW | Uni |    |    |    | US |
| <b>0.28</b> Keypad fwd/rev key enable    | {6.13}                                     | OFF (0) or On (1)  |  |            | OFF (0)  |                             |         | RW | Bit |    |    |    | US |

| Parameter |  |         | Range(⇅)  |                       |               | Default(⇨)  |                                |  | Type |     |  |    |    |    |
|-----------|--|---------|---|-----------------------|---------------|---|--------------------------------|--|------|-----|--|----|----|----|
|           |  |         | OL  | VT                    | SV            | OL  | VT                             | SV   |      |     |  |    |    |    |
| 0.29      | SMARTCARD parameter data                   | {11.36} | 0 to 999  |                       |               | 0   |                                |  | RO   | Uni |  | NC | PT | US |
| 0.30      | Parameter cloning                          | {11.42} | nonE (0), rEAd (1), Prog (2), AuTO (3), boot (4)  |                       |               | nonE (0)  |                                |  | RW   | Txt |  | NC |    | *  |
| 0.31      | Drive rated voltage                        | {11.33} | 200 (0), 400 (1), 575 (2), 690 (3) V  |                       |               |   |                                |  | RO   | Txt |  | NC | PT |    |
| 0.32      | Drive rated current                        | {11.32} | 0.00 to 9999.99A  |                       |               |   |                                |  | RO   | Uni |  | NC | PT |    |
| 0.33      | OL> Catch a spinning motor                 | {6.09}  | 0 to 3  |                       |               | 0   |                                |  | RW   | Uni |  |    |    | US |
|           | VT> Rated rpm autotune                     | {5.16}  |   |                       | 0 to 2        | 0   |                                |  | RW   | Uni |  |    |    | US |
| 0.34      | User security code                         | {11.30} | 0 to 999  |                       |               | 0   |                                |  | RW   | Uni |  | NC | PT | PS |
| 0.35      | Serial comms mode                          | {11.24} | AnSI (0), rtu (1), Lcd (2)  |                       |               | rtU (1)   |                                |  | RW   | Txt |  |    |    | US |
| 0.36      | Serial comms baud rate                     | {11.25} | 300 (0), 600 (1), 1200 (2), 2400 (3), 4800 (4), 9600 (5), 19200 (6), 38400 (7), 57600 (8) Modbus RTU only, 115200 (9) Modbus RTU only |                       |               | 19200 (6)   |                                |  | RW   | Txt |  |    |    | US |
| 0.37      | Serial comms address                       | {11.23} | 0 to 247  |                       |               | 1   |                                |  | RW   | Uni |  |    |    | US |
| 0.38      | Current loop P gain                        | {4.13}  | 0 to 30,000   |                       |               | All voltage ratings: 20   |                                | 200V drive: 75<br>400V drive: 150<br>575V drive: 180<br>690V drive: 215      | RW   | Uni |  |    |    | US |
| 0.39      | Current loop I gain                        | {4.14}  | 0 to 30,000   |                       |               | All voltage ratings: 40   |                                | 200V drive: 1000<br>400V drive: 2000<br>575V drive: 2400<br>690V drive: 3000 | RW   | Uni |  |    |    | US |
| 0.40      | Autotune                                   | {5.12}  | 0 to 2  | 0 to 4                | 0 to 6        | 0   |                                |  | RW   | Uni |  |    |    |    |
| 0.41      | Maximum switching frequency                | {5.18}  | 3 (0), 4 (1), 6 (2), 8 (3), 12 (4), 16 (5) kHz  |                       |               | 3 (0)   |                                | 6 (2)  | RW   | Txt |  | RA |    | US |
| 0.42      | No. of motor poles                         | {5.11}  | 0 to 60 (Auto to 120 pole)  |                       |               | 0 (Auto)  |                                | 6 POLE (3)   | RW   | Txt |  |    |    | US |
| 0.43      | OL & VT> Motor rated power factor          | {5.10}  | 0.000 to 1.000  |                       |               | 0.850   |                                |  | RW   | Uni |  |    |    | US |
|           | SV> Encoder phase angle                    | {3.25}  |   |                       | 0.0 to 359.9° |   |                                | 0.0  | RW   | Uni |  |    |    | US |
| 0.44      | Motor rated voltage                        | {5.09}  | 0 to AC_voltage_set_max V   |                       |               | 200V drive: 230<br>400V drive: EUR> 400, USA> 460<br>575V drive: 575<br>690V drive: 690 |                                |  | RW   | Uni |  | RA |    | US |
| 0.45      | OL & VT> Motor rated full load speed (rpm) | {5.08}  | 0 to 180,000 rpm  | 0.00 to 40,000.00 rpm |               | EUR> 1,500<br>USA> 1,800  | EUR> 1,450.00<br>USA> 1,770.00 |  | RW   | Uni |  |    |    | US |
|           | SV> Motor thermal time constant            | {4.15}  |   |                       | 0.0 to 3000.0 |   |                                | 20.0   | RW   | Uni |  |    |    | US |
| 0.46      | Motor rated current                        | {5.07}  | 0 to Rated_current_max A  |                       |               | Drive rated current [11.32]   |                                |  | RW   | Uni |  | RA |    | US |
| 0.47      | Rated frequency                            | {5.06}  | 0 to 3,000.0 Hz   | 0 to 1,250.0 Hz       |               | EUR> 50.0<br>USA> 60.0  |                                |  | RW   | Uni |  |    |    | US |
| 0.48      | Operating mode selector                    | {11.31} | OPEn LP (1), CL VECt (2), SErVO (3), rEgEn (4)  |                       |               | OPEn LP (1)   | CL VECt (2)                    | SErVO (3)  | RW   | Txt |  | NC | PT |    |
| 0.49      | Security status                            | {11.44} | L1 (0), L2 (1), Loc (2)   |                       |               |   |                                |  | RW   | Txt |  |    | PT | US |
| 0.50      | Software version                           | {11.29} | 1.00 to 99.99   |                       |               |   |                                |  | RO   | Uni |  | NC | PT |    |

\* Modes 1 and 2 are not user saved, Modes 0, 3 and 4 are user saved

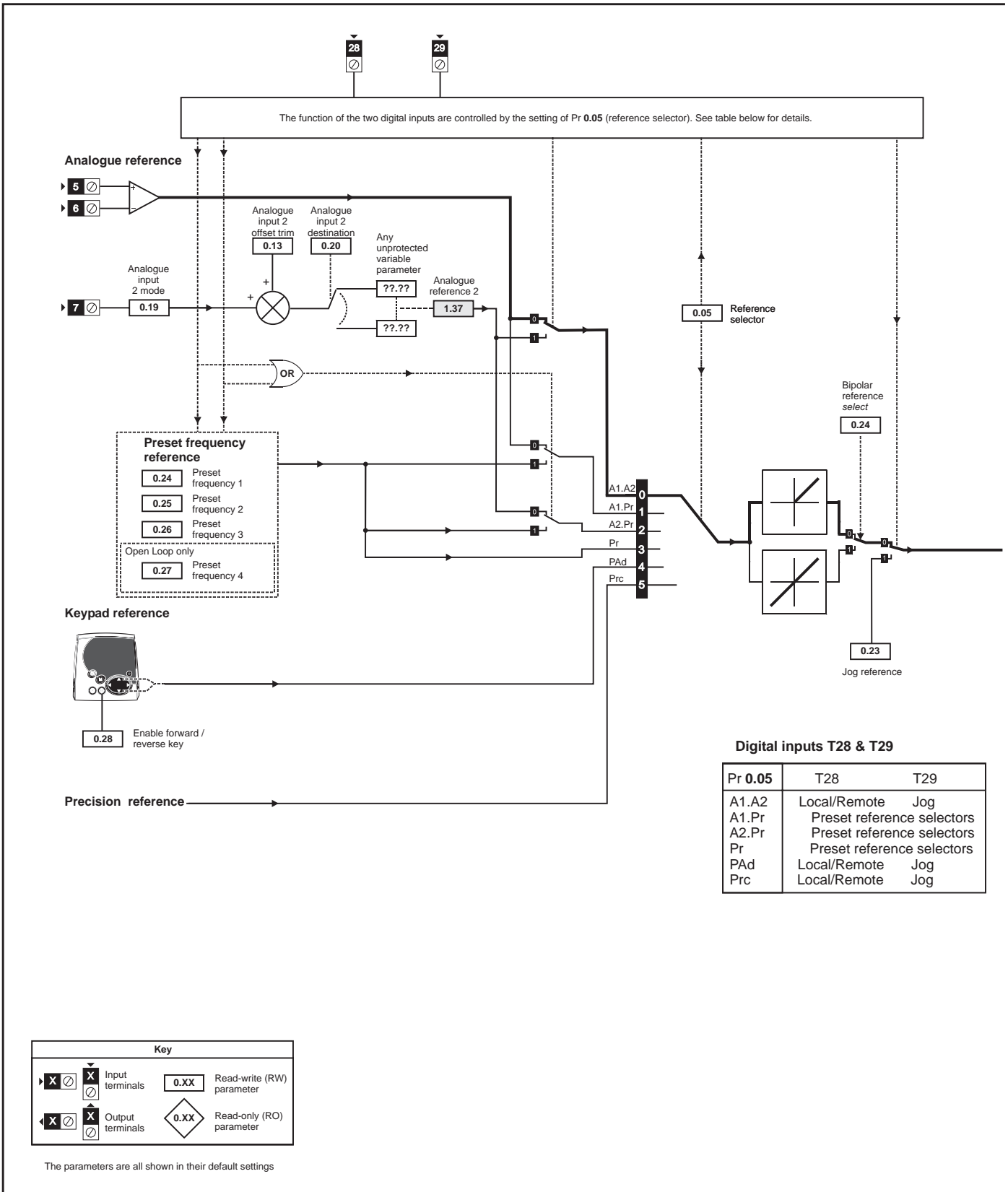
#### Key:

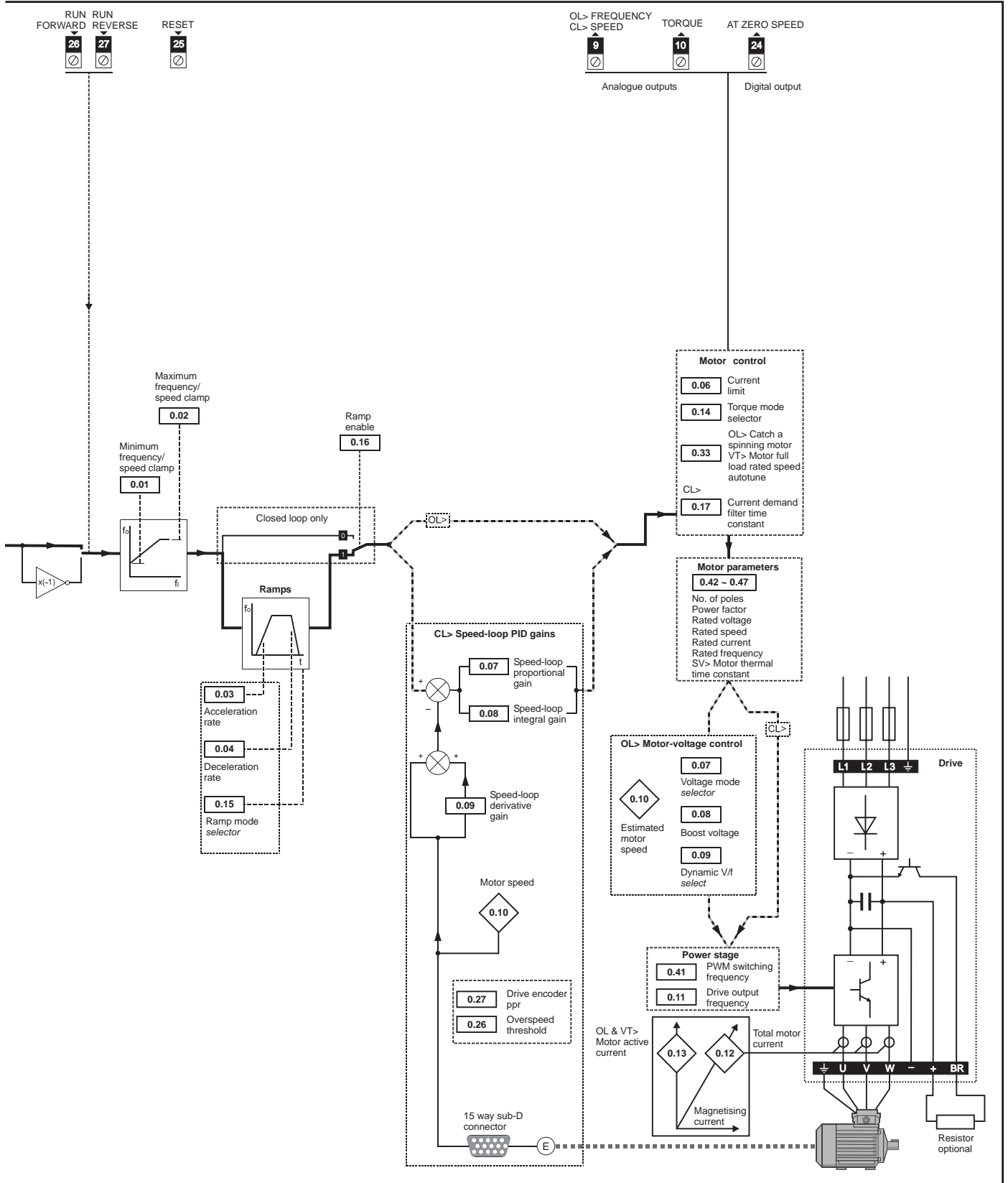
| Coding | Attribute  |
|--------|--|
| OL     | Open loop  |
| CL     | Closed loop vector and Servo   |
| VT     | Closed loop vector   |
| SV     | Servo  |
| {X.XX} | Cloned advanced parameter  |
| RW     | Read/write: can be written by the user   |
| RO     | Read only: can only be read by the user  |
| Bit    | 1 bit parameter: 'On' or 'OFF' on the display  |
| Bi     | Bipolar parameter  |
| Uni    | Unipolar parameter   |
| Txt    | Text: the parameter uses text strings instead of numbers.  |
| FI     | Filtered: some parameters which can have rapidly changing values are filtered when displayed on the drive keypad for easy viewing. |
| DE     | Destination: This parameter selects the destination of an input or logic function.   |

| Coding | Attribute  |
|--------|--|
| RA     | Rating dependant: this parameter is likely to have different values and ranges with drives of different voltage and current ratings. This parameters is not transferred by SMARTCARDS when the rating of the destination drive is different from the source drive. |
| NC     | Not cloned: not transferred to or from SMARTCARDS during cloning.  |
| PT     | Protected: cannot be used as a destination.  |
| US     | User save: parameter saved in drive EEPROM when the user initiates a parameter save.   |
| PS     | Power-down save: parameter automatically saved in drive EEPROM when the under volts (UV) trip occurs. With software version V01.08.00 and later, power-down save parameters are also saved in the drive when the user initiates a parameter save.                  |



Figure 6-1 Menu 0 logic diagram





## 6.2 Full descriptions

### 6.2.1 Parameter x.00

| 0.00 {x.00} Parameter zero |                 |
|----------------------------|-----------------|
| RW                         | Uni             |
| ↕                          | 0 to 32,767 ⇒ 0 |

Pr **x.00** is available in all menus and has the following functions.

| Value   | Action  |
|---------|---|
| 1000    | Save parameters when under voltage is not active (Pr <b>10.16</b> = 0) and low voltage DC supply is not active (Pr <b>6.44</b> = 0).                          |
| 1001    | Save parameters under all conditions  |
| 1070    | Reset all option modules  |
| 1233    | Load standard defaults  |
| 1244    | Load US defaults  |
| 1253    | Change drive mode with standard defaults  |
| 1254    | Change drive mode with US defaults  |
| 1255    | Change drive mode with standard defaults (excluding menus 15 to 20)   |
| 1256    | Change drive mode with US defaults (excluding menus 15 to 20)   |
| 3yyy*   | Transfer drive EEPROM data to a SMART Card block number yyy   |
| 4yyy*   | Transfer drive data as difference from defaults to SMART Card block number yyy  |
| 5yyy*   | Transfer drive ladder program to SMART Card block number yyy  |
| 6yyy*   | Transfer SMART Card data block number yyy to the drive  |
| 7yyy*   | Erase SMART Card data block number yyy  |
| 8yyy*   | Compare drive parameters with SMART Card data block number yyy  |
| 9555*   | Clear SMARTCARD warning suppression flag  |
| 9666*   | Set SMARTCARD warning suppression card  |
| 9777*   | Clear SMARTCARD read-only flag  |
| 9888*   | Set SMARTCARD read-only flag  |
| 9999*   | Erase SMARTCARD data block 1 to 499   |
| 110zy   | Transfer electronic nameplate parameters to/from drive from/to encoder. See the <i>Unidrive SP Advanced User Guide</i> for more information on this function. |
| 12000** | Display non-default values only   |
| 12001** | Display destination parameters only   |

\* See Chapter 9 *SMARTCARD operation* on page 151 for more information of these functions.

\*\* These functions do not require a drive reset to become active. All other functions require a drive reset to initiate the function.

### 6.2.2 Speed limits

| 0.01 {1.07} Minimum reference clamp |    |                           |     |
|-------------------------------------|----|---------------------------|-----|
| RW                                  | Bi | PT                        | US  |
| OL                                  | ↕  | ±3,000.0Hz ⇒              | 0.0 |
| CL                                  | ↕  | ±SPEED_LIMIT_MAX Hz/rpm ⇒ | 0.0 |

(When the drive is jogging, [0.01] has no effect.)

#### Open-loop

Set Pr **0.01** at the required minimum output frequency of the drive for both directions of rotation. The drive speed reference is scaled between Pr **0.01** and Pr **0.02**. [0.01] is a nominal value; slip compensation may cause the actual frequency to be higher.

#### Closed-loop

Set Pr **0.01** at the required minimum motor speed for both directions of rotation. The drive speed reference is scaled between Pr **0.01** and Pr **0.02**.

| 0.02 {1.06} Maximum reference clamp |     |  |
|-------------------------------------|-----|--|
| RW                                  | Uni | US   |
| OL                                  | ↕   | 0 to 3,000.0Hz ⇒ EUR> 50.0<br>USA> 60.0                                |
| CL                                  | ↕   | SPEED_LIMIT_MAX Hz/rpm ⇒ VT EUR> 1,500.0<br>USA> 1,800.0<br>SV 3,000.0 |

(The drive has additional over-speed protection.)

#### Open-loop

Set Pr **0.02** at the required maximum output frequency for both directions of rotation. The drive speed reference is scaled between Pr **0.01** and Pr **0.02**. [0.02] is a nominal value; slip compensation may cause the actual frequency to be higher.

#### Closed-loop

Set Pr **0.02** at the required maximum motor speed for both directions of rotation. The drive speed reference is scaled between Pr **0.01** and Pr **0.02**.

For operating at high speeds see section 8.6 *High speed operation* on page 149.

### 6.2.3 Ramps, speed reference selection, current limit

| 0.03 {2.11} Acceleration rate |     |  |
|-------------------------------|-----|--|
| RW                            | Uni | US   |
| OL                            | ↕   | 0.0 to 3,200.0 s/100Hz ⇒ 5.0                         |
| CL                            | ↕   | 0.000 to 3,200.000 s/1,000rpm ⇒ VT 2.000<br>SV 0.200 |

Set Pr **0.03** at the required rate of acceleration.

Note that larger values produce lower acceleration. The rate applies in both directions of rotation.

| 0.04 {2.21} Deceleration rate |     |  |
|-------------------------------|-----|--|
| RW                            | Uni | US   |
| OL                            | ↕   | 0.0 to 3,200.0 s/100Hz ⇒ 10.0                        |
| CL                            | ↕   | 0.000 to 3,200.000 s/1,000rpm ⇒ VT 2.000<br>SV 0.200 |

Set Pr **0.04** at the required rate of deceleration.

Note that larger values produce lower deceleration. The rate applies in both directions of rotation.

| 0.05 {1.14} Reference selector |        |    |           |
|--------------------------------|--------|----|-----------|
| RW                             | Txt    | NC | US        |
| ↕                              | 0 to 5 | ⇒  | A1.A2 (0) |

Use Pr **0.05** to select the required frequency/speed reference as follows:

| Setting |   |  |
|---------|---|--|
| A1.A2   | 0 | Analogue input 1 OR analogue input 2 selectable by digital input, terminal 28              |
| A1.Pr   | 1 | Analogue input 1 OR preset frequency/speed selectable by digital input, terminal 28 and 29 |
| A2.Pr   | 2 | Analogue input 2 OR preset frequency/speed selectable by digital input, terminal 28 and 29 |
| Pr      | 3 | Pre-set frequency/speed  |
| PAd     | 4 | Keypad reference   |
| Prc     | 5 | Precision reference  |

Setting Pr **0.05** to 1, 2 or 3 will re-configure T28 and T29. Refer to Pr **8.39** (Pr **0.16** in OL) to disable this function.

| 0.06 {4.07} Current Limit |                          | RW | Uni | RA | US    |
|---------------------------|--------------------------|----|-----|----|-------|
| ↕                         | 0 to Current_limit_max % | ⇒  |     | OL | 165.0 |
|                           |                          |    |     | CL | 175.0 |

Pr **0.06** limits the maximum output current of the drive (and hence maximum motor torque) to protect the drive and motor from overload. Set Pr **0.06** at the required maximum torque as a percentage of the rated torque of the motor, as follows:

$$[0.06] = \frac{T_R}{T_{RATED}} \times 100 (\%)$$

Where:

$T_R$  Required maximum torque  
 $T_{RATED}$  Motor rated torque

Alternatively, set 0.06 at the required maximum active (torque-producing) current as a percentage of the rated active current of the motor, as follows:

$$[0.06] = \frac{I_R}{I_{RATED}} \times 100 (\%)$$

Where:

$I_R$  Required maximum active current  
 $I_{RATED}$  Motor rated active current

### 6.2.4 Voltage boost, (open-loop), Speed-loop PID gains (closed-loop)

| 0.07 {5.14} Voltage mode selector |   | RW | Txt  | US       |
|-----------------------------------|---|----|--|----------|
| OL                                | ↕ | ⇒  | Ur_S (0), Ur (1), Fd (2),<br>Ur_Auto (3), Ur_I (4),<br>SrE (5) | Ur_I (4) |

#### Open-loop

There are six voltage modes available, which fall into two categories, vector control and fixed boost. For further details, refer to section Pr 0.07 {5.14} *Voltage mode* on page 139.

| 0.07 {3.10} Speed controller proportional gain |   | RW | Uni                                       | US     |
|--|---|----|---|--------|
| CL   | ↕ | ⇒  | 0.0000 to 6.5535<br>1/rad s <sup>-1</sup> | 0.0100 |

#### Closed-loop

Pr **0.07 (3.10)** operates in the feed-forward path of the speed-control loop in the drive. See Figure 11-4 on page 176 for a schematic of the speed controller. For information on setting up the speed controller gains, refer to Chapter 8 *Optimisation* on page 138.

| 0.08 {5.15} Low frequency voltage boost |   | RW | Uni                                 | US   |
|---|---|----|-------------------------------------|--|
| OL                                      | ↕ | ⇒  | 0.0 to 25.0% of motor rated voltage | Size 1 to 3: 3.0<br>Size 4 & 5: 2.0<br>Size 6: 1.0 |

#### Open-loop

When **0.07 Voltage mode selector** is set at **Fd** or **SrE**, set Pr **0.08 (5.15)** at the required value for the motor to run reliably at low speeds.

Excessive values of Pr **0.08** can cause the motor to be overheated.

| 0.08 {3.11} Speed controller integral gain |   | RW | Uni                     | US   |
|--|---|----|-------------------------|------|
| CL   | ↕ | ⇒  | 0.00 to 655.35<br>1/rad | 1.00 |

#### Closed-loop

Pr **0.08 (3.11)** operates in the feed-forward path of the speed-control loop in the drive. See Figure 11-4 on page 176 for a schematic of the speed controller. For information on setting up the speed controller gains, refer to Chapter 8 *Optimisation* on page 138.

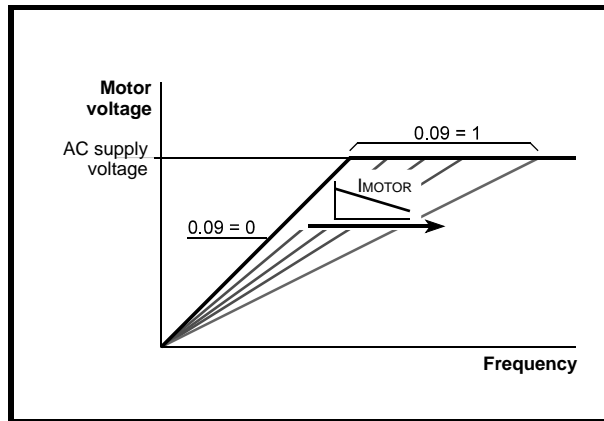
| 0.09 {5.13} Dynamic V/F / flux optimise select |   | RW | Bit               | US      |
|--|---|----|-------------------|---------|
| OL   | ↕ | ⇒  | OFF (0) or On (1) | OFF (0) |

#### Open-loop

Set Pr **0.09 (5.13)** at 0 when the V/f characteristic applied to the motor is to be fixed. It is then based on the rated voltage and frequency of the motor.

Set Pr **0.09** at 1 when reduced power dissipation is required in the motor when it is lightly loaded. The V/f characteristic is then variable resulting in the motor voltage being proportionally reduced for lower motor currents. Figure 6-2 shows the change in V/f slope when the motor current is reduced.

Figure 6-2 Fixed and variable V/f characteristics



| 0.09 {3.12} Speed controller differential feedback gain |   | RW | Uni                   | US      |
|---|---|----|-----------------------|---------|
| CL  | ↕ | ⇒  | 0.00000 to 0.65535(s) | 0.00000 |

#### Closed-loop

Pr **0.09 (3.12)** operates in the feedback path of the speed-control loop in the drive. See Figure 11-4 on page 176 for a schematic of the speed controller. For information on setting up the speed controller gains, refer to Chapter 8 *Optimisation* on page 138.

### 6.2.5 Monitoring

| 0.10 {5.04} Estimated motor speed |   | RO | Bit | FI           | NC | PT |
|-----------------------------------|---|----|-----|--------------|----|----|
| OL                                | ↕ | ⇒  |     | ±180,000 rpm |    |    |

#### Open-loop

Pr **0.10 (5.04)** indicates the value of motor speed that is estimated from the following:

- 0.12 Post-ramp frequency reference
- 0.42 Motor - no. of poles

|                                |    |                |  |  |  |    |    |  |  |  |  |  |  |
|--------------------------------|----|----------------|--|--|--|----|----|--|--|--|--|--|--|
| <b>0.10 {3.02} Motor speed</b> |    |                |  |  |  |    |    |  |  |  |  |  |  |
| RO                             | Bi | FI             |  |  |  | NC | PT |  |  |  |  |  |  |
| CL                             | ⇕  | ±Speed_max rpm |  |  |  |    | ⇒  |  |  |  |  |  |  |

#### Closed-loop

Pr **0.10 (3.02)** indicates the value of motor speed that is obtained from the speed feedback.

|   |    |                    |  |  |  |    |    |  |  |  |  |  |  |
|---|----|--------------------|--|--|--|----|----|--|--|--|--|--|--|
| <b>0.11 {5.01} Drive output frequency</b> |    |                    |  |  |  |    |    |  |  |  |  |  |  |
| RO  | Bi | FI                 |  |  |  | NC | PT |  |  |  |  |  |  |
| OL  | ⇕  | ±Speed_freq_max Hz |  |  |  |    | ⇒  |  |  |  |  |  |  |
| VT  |    |                    |  |  |  |    |    |  |  |  |  |  |  |

#### Open-loop & closed loop vector

Pr **0.11** displays the frequency at the drive output.

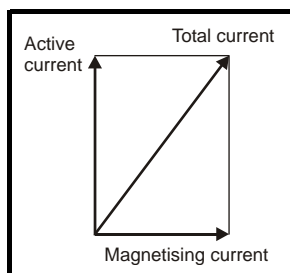
|   |     |  |  |  |  |    |    |  |  |  |  |  |  |
|---|-----|--|--|--|--|----|----|--|--|--|--|--|--|
| <b>0.11 {3.29} Drive encoder position</b> |     |  |  |  |  |    |    |  |  |  |  |  |  |
| RO  | Uni | FI   |  |  |  | NC | PT |  |  |  |  |  |  |
| SV  | ⇕   | 0 to 65,535<br>1/2 <sup>16</sup> ths of a revolution |  |  |  |    | ⇒  |  |  |  |  |  |  |

#### Servo

Pr **0.11** displays the position of the encoder in mechanical values of 0 to 65,535. There are 65,536 units to one mechanical revolution.

|  |     |                          |  |  |  |    |    |  |  |  |  |  |  |
|--|-----|--------------------------|--|--|--|----|----|--|--|--|--|--|--|
| <b>0.12 {4.01} Total motor current</b> |     |                          |  |  |  |    |    |  |  |  |  |  |  |
| RO                                     | Uni | FI                       |  |  |  | NC | PT |  |  |  |  |  |  |
| ⇕                                      |     | 0 to Drive_current_max A |  |  |  |    | ⇒  |  |  |  |  |  |  |

Pr **0.12** displays the rms value of the output current of the drive in each of the three phases. The phase currents consist of an active component and a reactive component, which can form a resultant current vector as shown in the following diagram.



The active current is the torque producing current and the reactive current is the magnetising or flux-producing current.

|   |    |                      |  |  |  |    |    |  |  |  |  |  |  |
|---|----|----------------------|--|--|--|----|----|--|--|--|--|--|--|
| <b>0.13 {4.02} Motor active current</b> |    |                      |  |  |  |    |    |  |  |  |  |  |  |
| RO                                      | Bi | FI                   |  |  |  | NC | PT |  |  |  |  |  |  |
| OL                                      | ⇕  | ±Drive_current_max A |  |  |  |    | ⇒  |  |  |  |  |  |  |
| VT                                      |    |                      |  |  |  |    |    |  |  |  |  |  |  |

#### Open-loop & closed loop vector

When the motor is being driven below its rated speed, the torque is proportional to [0.13].

|   |    |           |  |  |  |  |   |       |  |  |    |  |  |
|---|----|-----------|--|--|--|--|---|-------|--|--|----|--|--|
| <b>0.13 {7.07} Analogue input 1 offset trim</b> |    |           |  |  |  |  |   |       |  |  |    |  |  |
| RW  | Bi |           |  |  |  |  |   |       |  |  | US |  |  |
| SV  | ⇕  | ±10.000 % |  |  |  |  | ⇒ | 0.000 |  |  |    |  |  |

#### Servo

Pr **0.13** can be used to trim out any offset in the user signal to analogue input 1.

### 6.2.6 Jog reference, Ramp mode selector, Stop and torque mode selectors

|   |     |        |  |  |  |  |   |                   |  |  |    |  |  |
|---|-----|--------|--|--|--|--|---|-------------------|--|--|----|--|--|
| <b>0.14 {4.11} Torque mode selector</b> |     |        |  |  |  |  |   |                   |  |  |    |  |  |
| RW                                      | Uni |        |  |  |  |  |   |                   |  |  | US |  |  |
| OL                                      | ⇕   | 0 to 1 |  |  |  |  | ⇒ | Speed control (0) |  |  |    |  |  |
| CL                                      | ⇕   | 0 to 4 |  |  |  |  | ⇒ |                   |  |  |    |  |  |

Pr **0.14** is used to select the required control mode of the drive as follows:

| Setting | Open-Loop         | Closed-Loop                            |
|---------|-------------------|--|
| 0       | Frequency control | Speed control                          |
| 1       | Torque control    | Torque control                         |
| 2       |                   | Torque control with speed override     |
| 3       |                   | Coiler/uncoiler mode                   |
| 4       |                   | Speed control with torque feed-forward |

|                                     |     |                                   |  |  |  |  |   |         |  |  |    |  |  |
|-------------------------------------|-----|-----------------------------------|--|--|--|--|---|---------|--|--|----|--|--|
| <b>0.15 {2.04} Ramp mode select</b> |     |                                   |  |  |  |  |   |         |  |  |    |  |  |
| RW                                  | Txt |                                   |  |  |  |  |   |         |  |  | US |  |  |
| OL                                  | ⇕   | FASt (0)<br>Std (1)<br>Std.hV (2) |  |  |  |  | ⇒ | Std (1) |  |  |    |  |  |
| CL                                  | ⇕   | FASt (0)<br>Std (1)               |  |  |  |  | ⇒ |         |  |  |    |  |  |

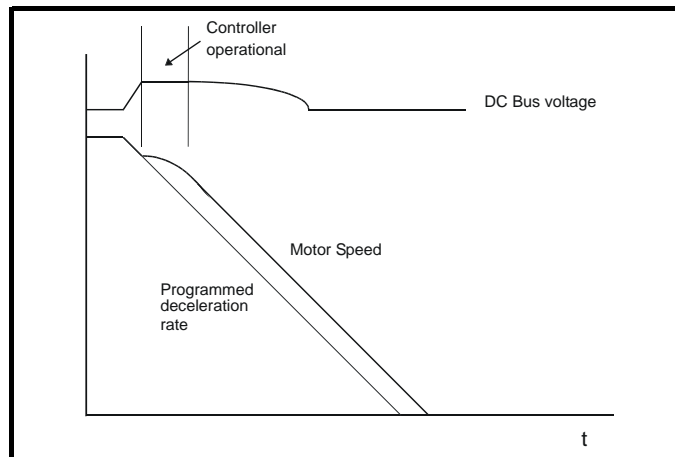
Pr **0.15** sets the ramp mode of the drive as shown below:

#### 0: Fast ramp

Fast ramp is used where the deceleration follows the programmed deceleration rate subject to current limits. This mode must be used if a braking resistor is connected to the drive.

#### 1: Standard ramp

Standard ramp is used. During deceleration, if the voltage rises to the standard ramp level (Pr **2.08**) it causes a controller to operate, the output of which changes the demanded load current in the motor. As the controller regulates the link voltage, the motor deceleration increases as the speed approaches zero speed. When the motor deceleration rate reaches the programmed deceleration rate the controller ceases to operate and the drive continues to decelerate at the programmed rate. If the standard ramp voltage (Pr **2.08**) is set lower than the nominal DC bus level the drive will not decelerate the motor, but it will coast to rest. The output of the ramp controller (when active) is a current demand that is fed to the frequency changing current controller (Open-loop modes) or the torque producing current controller (Closed-loop vector or Servo modes). The gain of these controllers can be modified with Pr **4.13** and Pr **4.14**.



## 2: Standard ramp with motor voltage boost

This mode is the same as normal standard ramp mode except that the motor voltage is boosted by 20%. This increases the losses in the motor, dissipating some of the mechanical energy as heat giving faster deceleration.

|   |                   |
|---|-------------------|
| <b>0.16 {8.39} T28 and T29 auto-selection disable</b> |                   |
| RW  | Bit               |
| OL  | ⇅                 |
|   | OFF (0) or On (1) |
|   | ⇒                 |
|   | OFF (0)           |

### Open-loop

When Pr 0.16 is set to 0, digital inputs T28 and T29 are set up automatically with destinations according to the setting of the reference select Pr 0.05.

| Reference select 0.05 | Terminal 28 function                                       | Terminal 29 function    |
|-----------------------|--|-------------------------|
| A1.A2 (0)             | Reference selection by terminal input                      | Local / remote selector |
| A1.Pr (1)             | Analogue reference 1 or presets selected by terminal input | Jog select              |
| A2.Pr (2)             | Analogue reference 2 or presets selected by terminal input | Preset select bit 0     |
| Pr (3)                | Preset reference selected by terminal input                | Preset select bit 1     |
| PAd (4)               | Keypad reference selected                                  | Local / remote selector |
| Prc (5)               | Precision reference selected                               | Jog select              |

Setting Pr 0.16 to 1 disables this automatic set-up, allowing the user to define the function of digital inputs T28 and T29.

|                                |                   |
|--------------------------------|-------------------|
| <b>0.16 {2.02} Ramp enable</b> |                   |
| RW                             | Bit               |
| CL                             | ⇅                 |
|                                | OFF (0) or On (1) |
|                                | ⇒                 |
|                                | On (1)            |

Setting Pr 0.16 to 0 allows the user to disable the ramps. This is generally used when the drive is required to closely follow a speed reference which already contains acceleration and deceleration ramps.

|  |                     |
|--|---------------------|
| <b>0.17 {8.26} T29 digital input destination</b> |                     |
| RW   | Uni                 |
| OL   | ⇅                   |
|  | Pr 0.00 to Pr 21.51 |
|  | ⇒                   |
|  | Pr 6.31             |

### Open-loop

Pr 0.17 sets the destination of digital input T29. This parameter is normally set-up automatically according to the reference selected by

Pr 0.05. In order to manually set-up this parameter, the T28 and T29 auto-selection disable (Pr 0.16) must be set.

|  |                |
|--|----------------|
| <b>0.17 {4.12} Current demand filter time constant</b> |                |
| RW   | Uni            |
| CL   | ⇅              |
|  | 0.0 to 25.0 ms |
|  | ⇒              |
|  | 0.0            |

### Closed-loop

A first order filter, with a time constant defined by Pr 0.17, is provided on the current demand to reduce acoustic noise and vibration produced as a result of position feedback quantisation noise. The filter introduces a lag in the speed loop, and so the speed loop gains may need to be reduced to maintain stability as the filter time constant is increased.

|  |                   |
|--|-------------------|
| <b>0.18 {8.29} Positive logic select</b> |                   |
| RW                                       | Bit               |
| PT                                       | US                |
| ⇅  | OFF (0) or On (1) |
|  | ⇒                 |
|  | On (1)            |

Pr 0.18 sets the logic polarity for digital inputs and digital outputs. This does not affect the drive enable input or the relay output.

|  |          |
|--|----------|
| <b>0.19 {7.11} Analogue input 2 mode</b> |          |
| RW                                       | Txt      |
| US                                       |          |
| ⇅  | 0 to 6   |
|  | ⇒        |
|  | VOLt (6) |

In modes 2 & 3 a current loop loss trip is generated if the current falls below 3mA.

In modes 2 & 4 the analogue input level goes to 0.0% if the input current falls below 4mA.

| Pr value | Pr string | Mode                          | Comments        |
|----------|-----------|-------------------------------|-----------------|
| 0        | 0-20      | 0 - 20mA                      |                 |
| 1        | 20-0      | 20 - 0mA                      |                 |
| 2        | 4-20.tr   | 4 - 20mA with trip on loss    | Trip if I < 3mA |
| 3        | 20-4.tr   | 20 - 4mA with trip on loss    | Trip if I < 3mA |
| 4        | 4-20      | 4 - 20mA with no trip on loss | 0.0% if I ≤ 4mA |
| 5        | 20-4      | 20 - 4mA with no trip on loss | 100% if I ≤ 4mA |
| 6        | VOLt      | Voltage mode                  |                 |

|   |                     |
|---|---------------------|
| <b>0.20 {7.14} Analogue input 2 destination</b> |                     |
| RW  | Uni                 |
| DE  |                     |
| PT  | US                  |
| ⇅   | Pr 0.00 to Pr 21.51 |
|   | ⇒                   |
|   | Pr 1.37             |

Pr 0.20 sets the destination of analogue input 2.

| 0.21 {7.15} Analogue input 3 mode |        |  |  |  |   |        |    |    |  |
|-----------------------------------|--------|--|--|--|---|--------|----|----|--|
| RW                                | Txt    |  |  |  |   |        | PT | US |  |
| ⇕                                 | 0 to 9 |  |  |  | ⇒ | th (8) |    |    |  |

Software V01.07.00 and later, the default is th (8)

Software V01.06.02 and earlier, the default is VOLt (6)

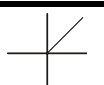
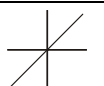
In modes 2 & 3 a current loop loss trip is generated if the current falls below 3mA.

In modes 2 & 4 the analogue input level goes to 0.0% if the input current falls below 4mA.

| Pr value | Pr string | Mode  | Comments   |
|----------|-----------|---|--|
| 0        | 0-20      | 0 - 20mA  |  |
| 1        | 20-0      | 20 - 0mA  |  |
| 2        | 4-20.tr   | 4 - 20mA with trip on loss                      | Trip if I < 3mA  |
| 3        | 20-4.tr   | 20 - 4mA with trip on loss                      | Trip if I < 3mA  |
| 4        | 4-20      | 4 - 20mA with no trip on loss                   | 0.0% if I ≤ 4mA  |
| 5        | 20-4      | 20 - 4mA with no trip on loss                   | 100% if I ≤ 4mA  |
| 6        | VOLt      | Voltage mode                                    |  |
| 7        | th.SC     | Thermistor mode with short-circuit detection    | Th trip if R > 3K3<br>Th reset if R < 1K8<br>ThS trip if R < 50R |
| 8        | th        | Thermistor mode with no short-circuit detection | Th trip if R > 3K3<br>Th reset if R < 1K8                        |
| 9        | th.diSp   | Thermistor mode with display only and no trip   |  |

| 0.22 {1.10} Bipolar reference select |                   |  |  |  |   |         |  |    |  |
|--------------------------------------|-------------------|--|--|--|---|---------|--|----|--|
| RW                                   | Bit               |  |  |  |   |         |  | US |  |
| ⇕                                    | OFF (0) or On (1) |  |  |  | ⇒ | OFF (0) |  |    |  |

Pr 0.22 determines whether the reference is uni-polar or bi-polar as follows:

| Pr 0.22 | Function                           |   |
|---------|------------------------------------|---|
| 0       | Unipolar speed/frequency reference |  |
| 1       | Bipolar speed/frequency reference  |  |

| 0.23 {1.05} Jog reference |     |                  |  |  |  |   |     |    |  |  |
|---------------------------|-----|------------------|--|--|--|---|-----|----|--|--|
| RW                        | Uni |                  |  |  |  |   |     | US |  |  |
| OL                        | ⇕   | 0 to 400.0 Hz    |  |  |  | ⇒ | 0.0 |    |  |  |
| CL                        | ⇕   | 0 to 4,000.0 rpm |  |  |  | ⇒ |     |    |  |  |

Enter the required value of jog frequency/speed.

The frequency/speed limits affect the drive when jogging as follows:

| Frequency-limit parameter       | Limit applies |
|---------------------------------|---------------|
| Pr 0.01 Minimum reference clamp | No            |
| Pr 0.02 Maximum reference clamp | Yes           |

| 0.24 {1.21} Preset reference 1 |                      |  |  |  |   |     |  |    |  |
|--------------------------------|----------------------|--|--|--|---|-----|--|----|--|
| RW                             | Bi                   |  |  |  |   |     |  | US |  |
| ⇕                              | ±Speed_limit_max rpm |  |  |  | ⇒ | 0.0 |  |    |  |

| 0.25 {1.22} Preset reference 2 |                      |  |  |  |   |     |  |    |  |
|--------------------------------|----------------------|--|--|--|---|-----|--|----|--|
| RW                             | Bi                   |  |  |  |   |     |  | US |  |
| ⇕                              | ±Speed_limit_max rpm |  |  |  | ⇒ | 0.0 |  |    |  |

| 0.26 {1.23} Preset reference 3 |    |                        |  |  |  |   |     |    |  |  |
|--------------------------------|----|------------------------|--|--|--|---|-----|----|--|--|
| RW                             | Bi |                        |  |  |  |   |     | US |  |  |
| OL                             | ⇕  | ±Speed_freq_max Hz/rpm |  |  |  | ⇒ | 0.0 |    |  |  |

#### Open-loop

If the preset reference has been selected (see Pr 0.05), the speed at which the motor runs is determined by these parameters.

| 0.26 {3.08} Overspeed threshold |     |                 |  |  |  |   |   |    |  |  |
|---------------------------------|-----|-----------------|--|--|--|---|---|----|--|--|
| RW                              | Uni |                 |  |  |  |   |   | US |  |  |
| CL                              | ⇕   | 0 to 40,000 rpm |  |  |  | ⇒ | 0 |    |  |  |

#### Closed-loop

If the speed feedback (Pr 3.02) exceeds this level in either direction, an overspeed trip is produced. If this parameter is set to zero, the overspeed threshold is automatically set to 120% x SPEED\_FREQ\_MAX.

| 0.27 {1.24} Preset reference 4 |    |                        |  |  |  |   |     |    |  |  |
|--------------------------------|----|------------------------|--|--|--|---|-----|----|--|--|
| RW                             | Bi |                        |  |  |  |   |     | US |  |  |
| OL                             | ⇕  | ±Speed_freq_max Hz/rpm |  |  |  | ⇒ | 0.0 |    |  |  |

#### Open-loop

Refer to Pr 0.24 to Pr 0.26.

| 0.27 {3.34} Drive encoder lines per revolution |     |             |  |  |  |   |      |    |  |  |
|--|-----|-------------|--|--|--|---|------|----|--|--|
| RW   | Uni |             |  |  |  |   |      | US |  |  |
| VT   | ⇕   | 0 to 50,000 |  |  |  | ⇒ | 1024 |    |  |  |
| SV   | ⇕   |             |  |  |  | ⇒ | 4096 |    |  |  |

#### Closed-loop

Enter in Pr 0.27 the number of lines per revolution of the drive encoder.

| 0.28 {6.13} Keypad fwd/rev key enable |                   |  |  |  |   |         |  |    |  |
|---------------------------------------|-------------------|--|--|--|---|---------|--|----|--|
| RW                                    | Bit               |  |  |  |   |         |  | US |  |
| ⇕                                     | OFF (0) or On (1) |  |  |  | ⇒ | OFF (0) |  |    |  |

When a keypad is fitted, this parameter enables the forward/reverse key.

| 0.29 {11.36} SMARTCARD parameter data |          |  |  |  |   |    |    |    |  |
|---------------------------------------|----------|--|--|--|---|----|----|----|--|
| RO                                    | Uni      |  |  |  |   | NC | PT | US |  |
| ⇕                                     | 0 to 999 |  |  |  | ⇒ | 0  |    |    |  |

This parameter shows the number of the data block last transferred from a SMARTCARD to the drive.

|                                       |     |        |  |  |  |    |          |   |  |  |  |  |
|---------------------------------------|-----|--------|--|--|--|----|----------|---|--|--|--|--|
| <b>0.30 {11.42} Parameter cloning</b> |     |        |  |  |  |    |          |   |  |  |  |  |
| RW                                    | Txt |        |  |  |  | NC |          | * |  |  |  |  |
| ⇅                                     |     | 0 to 4 |  |  |  | ⇒  | nonE (0) |   |  |  |  |  |

\* Modes 1 and 2 are not user saved, Modes 0, 3 and 4 are user saved.

**NOTE**

If Pr **0.30** is equal to 1 or 2 this value is not transferred to the EEPROM or the drive. If Pr **0.30** is set to a 3 or 4 the value is transferred.

| Pr String | Pr value | Comment                                      |
|-----------|----------|--|
| nonE      | 0        | Inactive                                     |
| rEAd      | 1        | Read parameter set from the SMARTCARD        |
| Prog      | 2        | Programming a parameter set to the SMARTCARD |
| Auto      | 3        | Auto save                                    |
| boot      | 4        | Boot mode                                    |

For further information, please refer to Chapter 9 *SMARTCARD operation* on page 151.

|   |     |  |  |  |  |    |    |  |  |  |  |  |
|---|-----|--|--|--|--|----|----|--|--|--|--|--|
| <b>0.31 {11.33} Drive rated voltage</b> |     |  |  |  |  |    |    |  |  |  |  |  |
| RO                                      | Txt |  |  |  |  | NC | PT |  |  |  |  |  |
| ⇅                                       |     | 200V (0), 400V (1), 575V (2), 690V (3) |  |  |  | ⇒  |    |  |  |  |  |  |

Pr **0.31** indicates the voltage rating of the drive.

|   |     |                    |  |  |  |    |    |  |  |  |  |  |
|---|-----|--------------------|--|--|--|----|----|--|--|--|--|--|
| <b>0.32 {11.32} Drive rated current</b> |     |                    |  |  |  |    |    |  |  |  |  |  |
| RO                                      | Uni |                    |  |  |  | NC | PT |  |  |  |  |  |
| ⇅                                       |     | 0.00 to 9,999.99 A |  |  |  | ⇒  |    |  |  |  |  |  |

Pr **0.32** indicates the maximum continuous Heavy Duty current rating (which will allow for an overload of 150%).

|   |     |        |  |  |  |   |   |  |  |  |    |  |
|---|-----|--------|--|--|--|---|---|--|--|--|----|--|
| <b>0.33 {6.09} Catch a spinning motor</b> |     |        |  |  |  |   |   |  |  |  |    |  |
| RW  | Uni |        |  |  |  |   |   |  |  |  | US |  |
| OL  | ⇅   | 0 to 3 |  |  |  | ⇒ | 0 |  |  |  |    |  |

**Open-loop**

When the drive is enabled with Pr **0.33** = 0, the output frequency starts at zero and ramps to the required reference. When the drive is enabled when Pr **0.33** has a non-zero value, the drive performs a start-up test to determine the motor speed and then sets the initial output frequency to the synchronous frequency of the motor. Restrictions may be placed on the frequencies detected by the drive as follows:

| Pr 0.33 | Function                         |
|---------|----------------------------------|
| 0       | Disabled                         |
| 1       | Detect all frequencies           |
| 2       | Detect positive frequencies only |
| 3       | Detect negative frequencies only |

|                                       |     |        |  |  |  |   |   |  |  |  |    |  |
|---------------------------------------|-----|--------|--|--|--|---|---|--|--|--|----|--|
| <b>0.33 {5.16} Rated rpm autotune</b> |     |        |  |  |  |   |   |  |  |  |    |  |
| RW                                    | Uni |        |  |  |  |   |   |  |  |  | US |  |
| VT                                    | ⇅   | 0 to 2 |  |  |  | ⇒ | 0 |  |  |  |    |  |

**Closed-loop vector**

The motor rated full load rpm parameter (Pr **0.45**) in conjunction with the motor rated frequency parameter (Pr **0.46**) defines the full load slip of the motor. The slip is used in the motor model for closed-loop vector control. The full load slip of the motor varies with rotor resistance which can vary significantly with motor temperature. When Pr **0.33** is set to 1 or 2, the

drive can automatically sense if the value of slip defined by Pr **0.45** and Pr **0.46** has been set incorrectly or has varied with motor temperature. If the value is incorrect parameter Pr **0.45** is automatically adjusted. The adjusted value in Pr **0.45** is not saved at power-down. If the new value is required at the next power-up it must be saved by the user.

Automatic optimisation is only enabled when the speed is above 12.5% of rated speed, and when the load on the motor load rises above 62.5% of rated load. Optimisation is disabled again if the load falls below 50% of rated load.

For best optimisation results the correct values of stator resistance (Pr **5.17**), transient inductance (Pr **5.24**), stator inductance (Pr **5.25**) and saturation breakpoints (Pr **5.29**, Pr **5.30**) should be stored in the relevant parameters. These values can be obtained by the drive during an autotune (see Pr **0.40** for further details).

Rated rpm auto-tune is not available if the drive is not using external position/speed feedback.

The gain of the optimiser, and hence the speed with which it converges, can be set at a normal low level when Pr **0.33** is set to 1. If this parameter is set to 2 the gain is increased by a factor of 16 to give faster convergence.

|  |     |          |  |  |  |    |    |  |  |  |    |  |
|--|-----|----------|--|--|--|----|----|--|--|--|----|--|
| <b>0.34 {11.30} User security code</b> |     |          |  |  |  |    |    |  |  |  |    |  |
| RW                                     | Uni |          |  |  |  | NC | PT |  |  |  | PS |  |
| ⇅                                      |     | 0 to 999 |  |  |  | ⇒  | 0  |  |  |  |    |  |

If any number other than 0 is programmed into this parameter, user security is applied so that no parameters except parameter **0.49** can be adjusted with the LED keypad. When this parameter is read via an LED keypad it appears as zero.

For further details refer to section 5.9.3 *User Security* on page 107.

|                                       |     |                            |  |  |  |   |         |  |  |  |    |  |
|---------------------------------------|-----|----------------------------|--|--|--|---|---------|--|--|--|----|--|
| <b>0.35 {11.24} Serial comms mode</b> |     |                            |  |  |  |   |         |  |  |  |    |  |
| RW                                    | Txt |                            |  |  |  |   |         |  |  |  | US |  |
| ⇅                                     |     | AnSI (0), rtu (1), Lcd (2) |  |  |  | ⇒ | rtU (1) |  |  |  |    |  |

This parameter defines the communications protocol used by the 485 comms port on the drive. This parameter can be changed via the drive keypad, via a Solutions Module or via the comms interface itself. If it is changed via the comms interface, the response to the command uses the original protocol. The master should wait at least 20ms before send a new message using the new protocol. (Note: ANSI uses 7 data bits, 1 stop bit and even parity; Modbus RTU uses 8 data bits, 2 stops bits and no parity.)

| Comms value | String | Communications mode                                  |
|-------------|--------|--|
| 0           | AnSI   | ANSI   |
| 1           | rtU    | Modbus RTU protocol                                  |
| 2           | Lcd    | Modbus RTU protocol, but with an SM-Keypad Plus only |

**ANSI3.28 protocol**

Full details of the CT ANSI communications protocol are the *Unidrive SP Advanced User Guide*.

**Modbus RTU protocol**

Full details of the CT implementation of Modbus RTU are given in the *Unidrive SP Advanced User Guide*.

**Modbus RTU protocol, but with an SM-Keypad Plus only**

This setting is used for disabling communications access when the SM-Keypad Plus is used as a hardware key. See the *Unidrive SP Advanced User Guide* for more details.

| 0.36 {11.25} Serial comms baud rate |   |
|-------------------------------------|---|
| RW                                  | Txt   |
| ↕                                   | 300 (0), 600 (1), 1200 (2), 2400 (3), 4800 (4), 9600 (5), 19200 (6), 38400 (7), 57600 (8)*, 115200 (9)* |
|                                     | 19200 (6)   |

\* only applicable to Modbus RTU mode

This parameter can be changed via the drive keypad, via a Solutions Module or via the comms interface itself. If it is changed via the comms interface, the response to the command uses the original baud rate. The master should wait at least 20ms before send a new message using the new baud rate.

| 0.37 {11.23} Serial address |          |
|-----------------------------|----------|
| RW                          | Uni      |
| ↕                           | 0 to 247 |
|                             | 1        |

Used to define the unique address for the drive for the serial interface. The drive is always a slave.

#### Modbus RTU

When the Modbus RTU protocol is used addresses between 0 and 247 are permitted. Address 0 is used to globally address all slaves, and so this address should not be set in this parameter

#### ANSI

When the ANSI protocol is used the first digit is the group and the second digit is the address within a group. The maximum permitted group number is 9 and the maximum permitted address within a group is 9. Therefore, Pr **0.37** is limited to 99 in this mode. The value 00 is used to globally address all slaves on the system, and x0 is used to address all slaves of group x, therefore these addresses should not be set in this parameter.

| 0.38 {4.13} Current loop P gain |                         |
|---------------------------------|-------------------------|
| RW                              | Uni                     |
| OL ↕                            | 0 to 30,000             |
| CL ↕                            |                         |
|                                 | All voltage ratings: 20 |
|                                 | 200V drive: 75          |
|                                 | 400V drive: 150         |
|                                 | 575V drive: 180         |
|                                 | 690V drive: 215         |

| 0.39 {4.14} Current loop I gain |                         |
|---------------------------------|-------------------------|
| RW                              | Uni                     |
| OL ↕                            | 0 to 30,000             |
| CL ↕                            |                         |
|                                 | All voltage ratings: 40 |
|                                 | 200V drive: 1,000       |
|                                 | 400V drive: 2,000       |
|                                 | 575V drive: 2,400       |
|                                 | 690V drive: 3,000       |

These parameters control the proportional and integral gains of the current controller used in the open loop drive. The current controller either provides current limits or closed loop torque control by modifying the drive output frequency. The control loop is also used in its torque mode during mains loss, or when the controlled mode standard ramp is active and the drive is decelerating, to regulate the flow of current into the drive.

| 0.40 {5.12} Autotune |        |
|----------------------|--------|
| RW                   | Uni    |
| OL ↕                 | 0 to 2 |
| VT ↕                 | 0 to 4 |
| SV ↕                 | 0 to 6 |

#### Open-Loop

There are two autotune tests available in open loop mode, a stationary and a rotating test. A rotating autotune should be used whenever possible, so the measured value of power factor of the motor is used by the drive.

- The stationary autotune can be used when the motor is loaded and it is not possible to remove the load from the motor shaft.
- A rotating autotune first performs a stationary autotune, before rotating the motor at  $\frac{2}{3}$  base speed in the forward direction for several seconds. The motor must be free from load for the rotating autotune.

To perform an autotune, set Pr **0.40** to 1 for a stationary test or 2 for a rotating test, and provide the drive with both an enable signal (on terminal 31) and a run signal (on terminal 26 or 27).

Following the completion of an autotune test the drive will go into the inhibit state. The drive must be placed into a controlled disable condition before the drive can be made to run at the required reference. The drive can be put in to a controlled disable condition by removing the Secure Disable signal from terminal 31, setting the drive enable parameter Pr **6.15** to OFF (0) or disabling the drive via the control word (Pr **6.42** & Pr **6.43**).

For further information refer to section *Pr 0.40 {5.12} Autotune* on page 138.

#### Closed-loop

There are three autotune tests available in closed loop vector mode, a stationary test, a rotating test and an inertia measurement test. A stationary autotune will give moderate performance whereas a rotating autotune will give improved performance as it measures the actual values of the motor parameters required by the drive. An inertia measurement test should be performed separately to a stationary or rotating autotune.

- The stationary autotune can be used when the motor is loaded and it is not possible to remove the load from the motor shaft.
- A rotating autotune first performs a stationary autotune, before rotating the motor at  $\frac{2}{3}$  base speed in the forward direction for approximately 30 seconds. The motor must be free from load for the rotating autotune.
- The inertia measurement test can measure the total inertia of the load and the motor. This is used to set the speed loop gains (see *Speed loop gains*, below) and to provide torque feed forwards when required during acceleration. During the inertia measurement test the motor speed changes from  $\frac{1}{3}$  to  $\frac{2}{3}$  rated speed in the forward direction several times. The motor can be loaded with a constant torque load and still give an accurate result, however, non-linear loads and loads that change with speed will cause measurement errors.

To perform an autotune, set Pr **0.40** to 1 for a stationary test, 2 for a rotating test, or 3 for an inertia measurement test and provide the drive with both an enable signal (on terminal 31) and a run signal (on terminal 26 or 27).

Following the completion of an autotune test the drive will go into the inhibit state. The drive must be placed into a controlled disable condition before the drive can be made to run at the required reference. The drive can be put in to a controlled disable condition by removing the Secure Disable signal from terminal 31, setting the drive enable parameter Pr **6.15** to OFF (0) or disabling the drive via the control word (Pr **6.42** & Pr **6.43**).

Setting Pr **0.40** to 4 will cause the drive to calculate the current loop gains based on the previously measured values of motor resistance and inductance. The drive does not apply any voltage to the motor during this test. The drive will change Pr **0.40** back to 0 as soon as the calculations are complete (approximately 500ms).

For further information refer to section *Pr 0.40 {5.12} Autotune* on page 144.

### Servo

There are five autotune tests available in servo mode, a short low speed test, a normal low speed test, an inertia measurement test, a stationary test and a minimal movement test. A normal low speed should be done where possible as the drive measures the stator resistance and inductance of the motor, and from these calculates the current loop gains. An inertia measurement test should be performed separately to a short low speed or normal low speed autotune.

- A short low speed test will rotate the motor by 2 electrical revolutions (i.e. up to 2 mechanical revolutions) in the forward direction, and measure the encoder phase angle. The motor must be free from load for this test.
- A normal low speed test will rotate the motor by 2 electrical revolutions (i.e. up to 2 mechanical revolutions) in the forward direction. This test measures the encoder phase angle and updates other parameters including the current loop gains. The motor must be free from load for this test.
- The inertia measurement test can measure the total inertia of the load and the motor. This is used to set the speed loop gains and to provide torque feed forwards when required during acceleration. During the inertia measurement test the motor speed changes from  $\frac{1}{3}$  to  $\frac{2}{3}$  rated speed in the forward direction several times. The motor can be loaded with a constant torque load and still give an accurate result, however, non-linear loads and loads that change with speed will cause measurement errors.
- The stationary test only measures the motor resistance and inductance, and updates the current loop gain parameters. This test does not measure the encoder phase angle so this test needs to be done in conjunction with either the short low speed or minimal movement tests.
- The minimal movement test will move the motor through a small angle to measure the encoder phase angle. This test will operate correctly when the load is an inertia, and although a small amount of cogging and stiction is acceptable, this test cannot be used for a loaded motor.

To perform an autotune, set Pr **0.40** to 1 for a short low speed test, 2 for a normal low speed test, 3 for an inertia measurement test, 4 for a stationary test or 5 for a minimal movement test, and provide the drive with both an enable signal (on terminal 31) and a run signal (on terminal 26 or 27).

Following the completion of an autotune test the drive will go into the inhibit state. The drive must be placed into a controlled disable condition before the drive can be made to run at the required reference. The drive can be put in to a controlled disable condition by removing the Secure Disable signal from terminal 31, setting the drive enable parameter Pr **6.15** to OFF (0) or disabling the drive via the control word (Pr **6.42** & Pr **6.43**).

Setting Pr **0.40** to 6 will cause the drive to calculate the current loop gains based on the previously measured values of motor resistance and inductance. The drive does not apply any voltage to the motor during this test. The drive will change Pr **0.40** back to 0 as soon as the calculations are complete (approximately 500ms).

For further information refer to section *Pr 0.40 {5.12} Autotune* on page 146.

| 0.41 {5.18} Maximum switching frequency |   | RW | Txt  | RA | US                   |
|---|---|----|--|----|----------------------|
| OL                                      | ↕ |    |  | ⇒  | 3 (0)                |
| CL                                      | ↕ |    | 3 (0), 4 (1), 6 (2), 8 (3), 12 (4), 16 (5) kHz | ⇒  | VT 3 (0)<br>SV 6 (2) |

This parameter defines the required switching frequency. The drive may automatically reduce the actual switching frequency (without changing this parameter) if the power stage becomes too hot. A thermal model of the IGBT junction temperature is used based on the heatsink temperature and an instantaneous temperature drop using the drive output current and switching frequency. The estimated IGBT junction temperature is displayed in Pr **7.34**. If the temperature exceeds 145°C the switching frequency is reduced if this is possible (i.e. >3kHz). Reducing the switching frequency reduces the drive losses and the junction temperature displayed in Pr **7.34** also reduces. If the load condition persists the junction temperature may continue to rise again above 145°C and the drive cannot reduce the switching frequency further the drive will initiate an 'O.ht1' trip. Every second the drive will attempt to restore the switching frequency to the level set in Pr **0.41**.

The full range of switching frequencies is not available on all ratings of Unidrive SP. See section 8.5 *Switching frequency* on page 149, for the maximum available switching frequency for each drive rating.

### 6.2.7 Motor parameters

| 0.42 {5.11} No. of motor poles |   | RW | Txt                        | US                             |
|--------------------------------|---|----|----------------------------|--------------------------------|
| OL                             | ↕ |    |                            | ⇒ Auto (0)                     |
| CL                             | ↕ |    | 0 to 60 (Auto to 120 Pole) | ⇒ VT Auto (0)<br>SV 6 POLE (3) |

#### Open-loop

This parameter is used in the calculation of motor speed, and in applying the correct slip compensation. When auto is selected, the number of motor poles is automatically calculated from the rated frequency (Pr **0.47**) and the rated full load rpm (Pr **0.45**). The number of poles =  $120 * \text{rated frequency} / \text{rpm}$  rounded to the nearest even number.

#### Closed-loop vector

This parameter must be set correctly for the vector control algorithms to operate correctly. When auto is selected, the number of motor poles is automatically calculated from the rated frequency (Pr **0.47**) and the rated full load rpm (Pr **0.45**). The number of poles =  $120 * \text{rated frequency} / \text{rpm}$  rounded to the nearest even number.

#### Servo

This parameter must be set correctly for the vector control algorithms to operate correctly. When auto is selected the number of poles is set to 6.

| 0.43 {5.10} Motor rated power factor |   | RW | Uni            | US      |
|--------------------------------------|---|----|----------------|---------|
| OL                                   | ↕ |    |                | ⇒ 0.850 |
| VT                                   | ↕ |    | 0.000 to 1.000 | ⇒       |

The power factor is the true power factor of the motor, i.e. the angle between the motor voltage and current.

#### Open-loop vector

The power factor is used in conjunction with the motor rated current (Pr **0.46**) to calculate the rated active current and magnetising current of the motor. The rated active current is used extensively to control the drive, and the magnetising current is used in vector mode Rs compensation. It is important that this parameter is set up correctly.

This parameter is obtained by the drive during a rotational autotune. If a stationary autotune is carried out, then the nameplate value should be entered in Pr **0.43**.

#### Closed-loop vector

If the stator inductance (Pr **5.25**) contains a non-zero value, the power factor used by the drive is continuously calculated and used in the vector control algorithms (this will not update Pr **0.43**).

If the stator inductance is set to zero (Pr **5.25**) then the power factor written in Pr **0.43** is used in conjunction with the motor rated current and other motor parameters to calculate the rated active and magnetising currents which are used in the vector control algorithm.

This parameter is obtained by the drive during a rotational autotune. If a stationary autotune is carried out, then the nameplate value should be entered in Pr **0.43**.

|  |       |
|--|-------|
| <b>0.43 {3.25} Encoder phase angle</b> |       |
| RW                                     | Uni   |
| SV                                     | ⇕     |
| 0.0 to 359.9°                          | ⇒ 0.0 |

The phase angle between the rotor flux in a servo motor and the encoder position is required for the motor to operate correctly. If the phase angle is known it can be set in this parameter by the user. Alternatively the drive can automatically measure the phase angle by performing a phasing test (see autotune in servo mode Pr **0.40**). When the test is complete the new value is written to this parameter. The encoder phase angle can be modified at any time and becomes effective immediately. This parameter has a factory default value of 0.0, but is not affected when defaults are loaded by the user.

|  |   |
|--|---|
| <b>0.44 {5.09} Motor rated voltage</b> |   |
| RW                                     | Uni   |
| ⇕                                      | ⇒   |
| 0 to AC_voltage_set_max V              | ⇒ 200V drive: 230<br>400V drive: EUR> 400<br>USA> 460<br>575V drive: 575<br>690V drive: 690 |

#### Open-loop & Closed-loop Vector

Enter the value from the rating plate of the motor.

|  |                                  |
|--|----------------------------------|
| <b>0.45 {5.08} Motor rated full load speed (rpm)</b> |                                  |
| RW   | Uni                              |
| OL   | ⇕                                |
| 0 to 180,000 rpm                                     | ⇒ EUR> 1,500<br>USA> 1,800       |
| VT   | ⇕                                |
| 0.00 to 40,000.00 rpm                                | ⇒ EUR> 1,450.00<br>USA> 1,770.00 |

#### Open-loop

This is the speed at which the motor would rotate when supplied with its base frequency at rated voltage, under rated load conditions (= synchronous speed - slip speed). Entering the correct value into this parameter allows the drive to increase the output frequency as a function of load in order to compensate for this speed drop.

Slip compensation is disabled if Pr **0.45** is set to 0 or to synchronous speed, or if Pr **5.27** is set to 0.

If slip compensation is required this parameter should be set to the value from the rating plate of the motor, which should give the correct rpm for a hot machine. Sometimes it will be necessary to adjust this when the drive is commissioned because the nameplate value may be inaccurate. Slip compensation will operate correctly both below base speed and within the field weakening region. Slip compensation is normally used to correct for the motor speed to prevent speed variation with load. The rated load rpm can be set higher than synchronous speed to deliberately introduce speed droop. This can be useful to aid load sharing with mechanically coupled motors.

#### Closed loop vector

Rated load rpm is used with motor rated frequency to determine the full load slip of the motor which is used by the vector control algorithm. Incorrect setting of this parameter can result in the following:

- Reduced efficiency of motor operation
- Reduction of maximum torque available from the motor
- Failure to reach maximum speed
- Over-current trips
- Reduced transient performance
- Inaccurate control of absolute torque in torque control modes

The nameplate value is normally the value for a hot machine, however, some adjustment may be required when the drive is commissioned if the nameplate value is inaccurate. The rated full load rpm can be optimised by the drive (For further information, refer to section 8.1.3 *Closed loop vector motor control* on page 143).

|  |        |
|--|--------|
| <b>0.45 {4.15} Motor thermal time constant</b> |        |
| RW   | Uni    |
| SV   | ⇕      |
| 0 to 3000.0                                    | ⇒ 20.0 |

#### Servo

Pr **0.45** is the motor thermal time constant of the motor, and is used (along with the motor rated current Pr **0.46**, and total motor current Pr **0.12**) in the thermal model of the motor in applying thermal protection to the motor.

Setting this parameter to 0 disables the motor thermal protection.

For further details, refer to section 8.4 *Motor thermal protection* on page 148.

|  |                               |
|--|-------------------------------|
| <b>0.46 {5.07} Motor rated current</b> |                               |
| RW                                     | Uni                           |
| ⇕                                      | ⇒                             |
| 0 to Rated_current_max A               | ⇒ Drive rated current [11.32] |

Enter the name-plate value for the motor rated current.

|                                    |                        |
|------------------------------------|------------------------|
| <b>0.47 {5.06} Rated frequency</b> |                        |
| RW                                 | Uni                    |
| OL                                 | ⇕                      |
| 0 to 3,000.0Hz                     | ⇒ EUR> 50.0, USA> 60.0 |
| VT                                 | ⇕                      |
| 0 to 1,250.0Hz                     | ⇒ EUR> 50.0, USA> 60.0 |

#### Open-loop & Closed-loop vector

Enter the value from the rating plate of the motor.

### 6.2.8 Operating-mode selection

|   |                        |
|---|------------------------|
| <b>0.48 {11.31} Operating mode selector</b> |                        |
| RW  | Txt                    |
| NC  | PT                     |
| ⇕   | ⇒                      |
| 1 to 4                                      | ⇒ OL 1<br>VT 2<br>SV 3 |

The settings for Pr **0.48** are as follows:

| Setting | Operating mode       |
|---------|----------------------|
| OPEn LP | 1 Open-loop          |
| CL VECt | 2 Closed-loop Vector |
| SerVO   | 3 Servo              |
| rEgEn   | 4 Regen              |

This parameter defines the drive operating mode. Pr **xx.00** must be set to 1253 (European defaults) or 1254 (USA defaults) before this parameter can be changed. When the drive is reset to implement any change in this parameter, the default settings of all parameters will be

set according to the drive operating mode selected and saved in memory.

### 6.2.9 Status information

|                                     |        |  |  |  |  |  |   |    |    |  |  |  |
|-------------------------------------|--------|--|--|--|--|--|---|----|----|--|--|--|
| <b>0.49 {11.44} Security status</b> |        |  |  |  |  |  |   |    |    |  |  |  |
| RW                                  | Txt    |  |  |  |  |  |   | PT | US |  |  |  |
| ⇅                                   | 0 to 2 |  |  |  |  |  | ⇒ | 0  |    |  |  |  |

This parameter controls access via the drive LED keypad as follows:

| Value | String | Action  |
|-------|--------|---|
| 0     | L1     | Only menu 0 can be accessed   |
| 1     | L2     | All menus can be accessed   |
| 2     | Loc    | Lock user security when drive is reset.<br>(This parameter is set to L1 after reset.) |

The LED keypad can adjust this parameter even when user security is set.


|   |               |  |  |  |  |  |   |    |    |  |  |  |
|---|---------------|--|--|--|--|--|---|----|----|--|--|--|
| <b>0.50 {11.29} Software version number</b> |               |  |  |  |  |  |   |    |    |  |  |  |
| RO  | Uni           |  |  |  |  |  |   | NC | PT |  |  |  |
| ⇅   | 1.00 to 99.99 |  |  |  |  |  | ⇒ |    |    |  |  |  |

The parameter displays the software version of the drive.

# 7 Running the motor


This chapter takes the new user through all the essential steps to running a motor for the first time, in each of the possible operating modes.

For information on tuning the drive for the best performance, see Chapter 8 *Optimisation*.




Ensure that no damage or safety hazard could arise from the motor starting unexpectedly.


**WARNING**




The values of the motor parameters affect the protection of the motor. The default values in the drive should not be relied upon. It is essential that the correct value is entered in Pr **0.46 Motor rated current**. This affects the thermal protection of the motor.

**CAUTION**



If the keypad mode has been used previously, ensure that the keypad reference has been set to 0 using the  buttons as if the drive is started using the keypad it will run to the speed defined by the keypad reference (Pr **0.35**).

**CAUTION**



If the intended maximum speed affects the safety of the machinery, additional independent over-speed protection must be used.

**WARNING**

## 7.1 Quick start Connections

### 7.1.1 Basic requirements

This section shows the basic connections which must be made for the drive to run in the required mode. For minimal parameter settings to run in each mode please see the relevant part of section 7.3 *Quick Start commissioning* on page 130.

**Table 7-1 Minimum control connection requirements for each control mode**

| Drive control method  | Requirements  |
|-----------------------|---|
| Terminal mode         | Drive Enable<br>Speed reference<br>Run forward or run reverse command |
| Keypad mode           | Drive Enable  |
| Serial communications | Drive Enable<br>Serial communications link                            |

**Table 7-2 Minimum control connection requirements for each mode of operation**

| Operating mode          | Requirements  |
|-------------------------|---|
| Open loop mode          | Induction motor   |
| Closed loop vector mode | Induction motor with speed feedback                     |
| Closed loop servo mode  | Permanent magnet motor with speed and position feedback |

### Speed feedback

Suitable devices are:

- Incremental encoder (A, B or F, D with or without Z)
- Incremental encoder with forward and reverse outputs (F, R with or without Z)
- SINCOS encoder (with, or without Stegmann Hiperface, EnDat or SSI communications protocols)
- EnDat absolute encoder

### Speed and position feedback

Suitable devices are:

- Incremental encoder (A, B or F, D with or without Z) with commutation signals (U, V, W)
- Incremental encoder with forward and reverse outputs (F, R with or without Z) and commutation outputs (U, V, W)
- SINCOS encoder (with Stegmann Hiperface, EnDat or SSI communications protocols)
- EnDat absolute encoder

For Solutions Module terminal information see section 11.15 *Menus 15, 16 and 17: Solutions Module set-up* on page 217 or the appropriate Solutions Module option user guide.



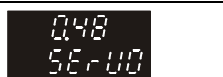
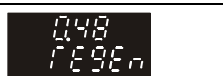
## 7.2 Changing the operating mode

Changing the operating mode returns all parameters to their default value, including the motor parameters. (Pr **0.49** and Pr **0.34** are not affected by this procedure.)

### Procedure


Use the following procedure only if a different operating mode is required:

1. Enter either of the following values in Pr **xx.00**, as appropriate:  
1253 (Europe, 50Hz AC supply frequency)  
1254 (USA, 60Hz AC supply frequency)
2. Change the setting of Pr **0.48** as follows:

| Pr 0.48 setting  | Operating mode  |
|--|---|
|    | 1 Open-loop   |
|   | 2 Closed-loop Vector  |
|  | 3 Closed-loop Servo   |
|  | 4 Regen (See the <i>Unidrive SP Regen Installation Guide</i> for more information about operating in this mode) |

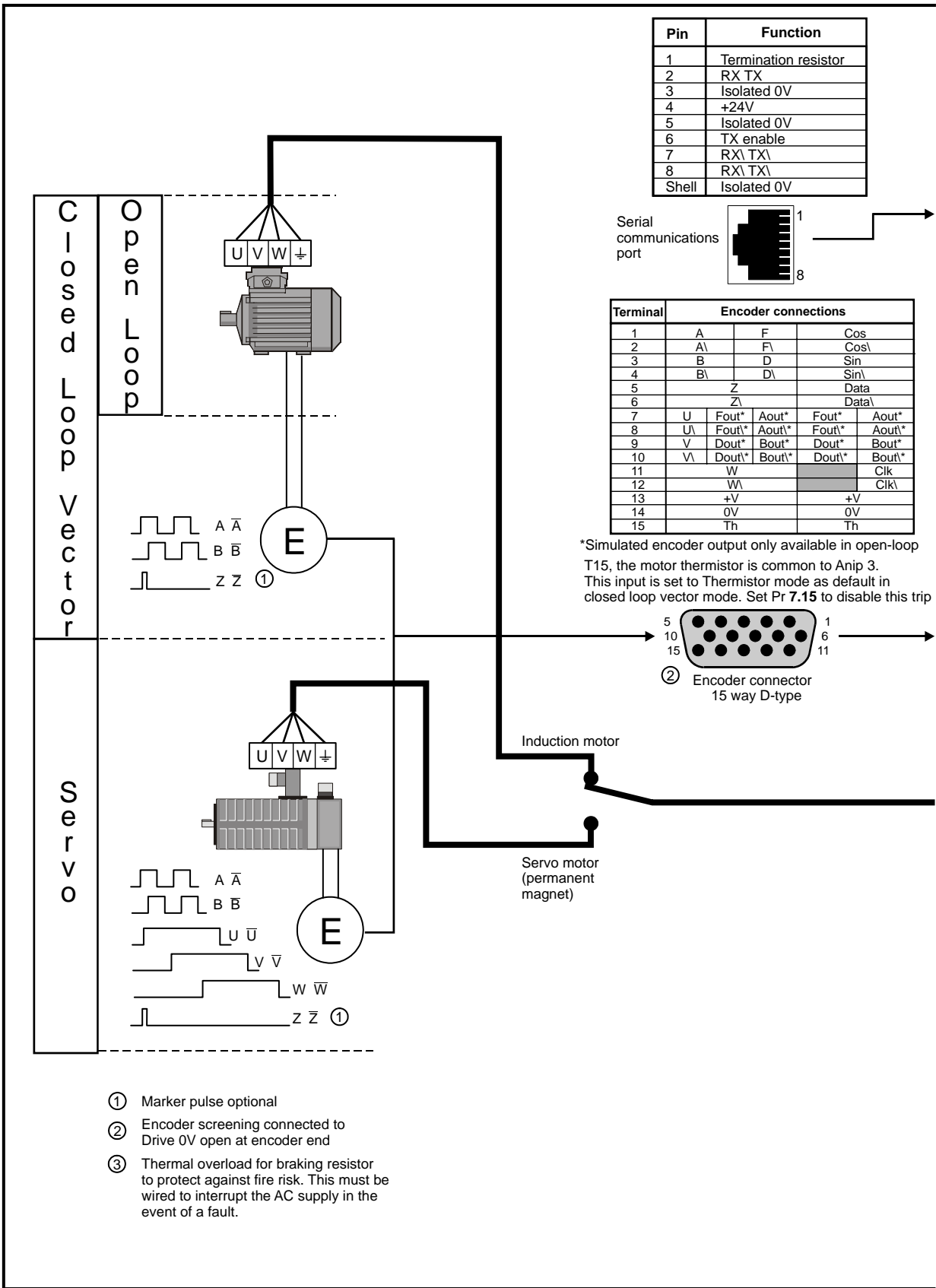
The figures in the second column apply when serial communications are used.

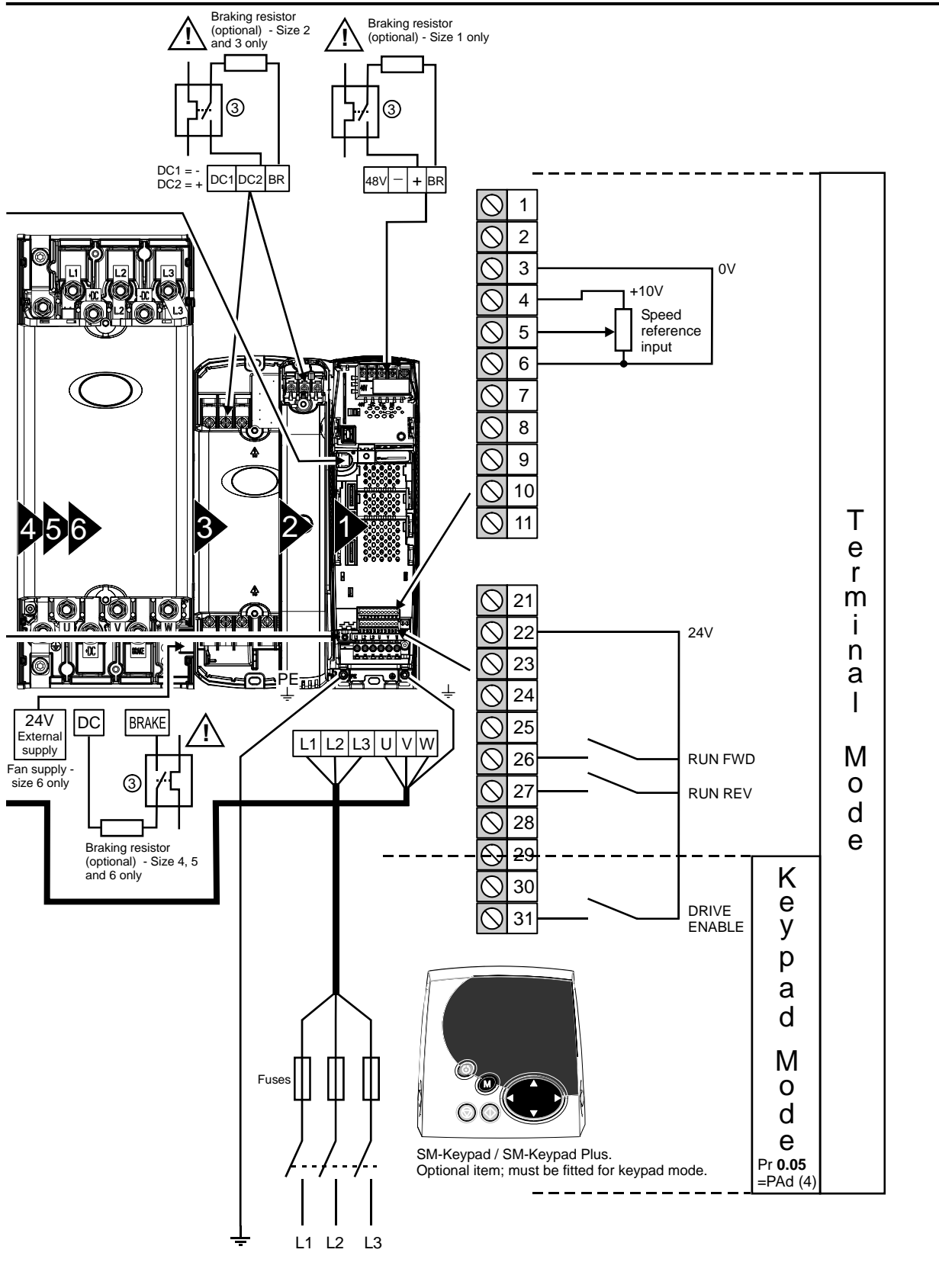
3. Either:

- Press the red  reset button
- Toggle the reset digital input
- Carry out a drive reset through serial communications by setting Pr **10.38** to 100 (ensure that Pr. **xx.00** returns to 0).

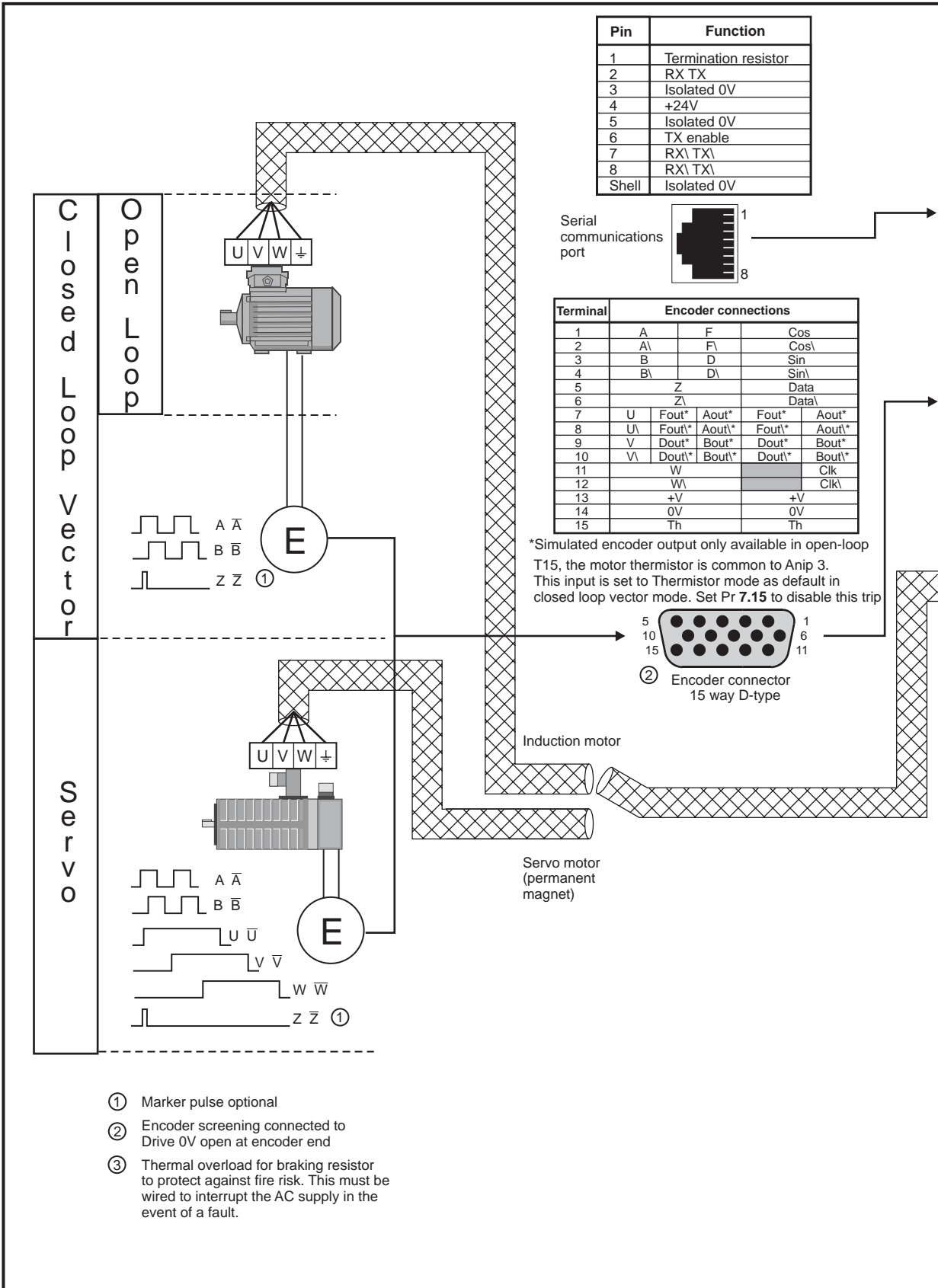


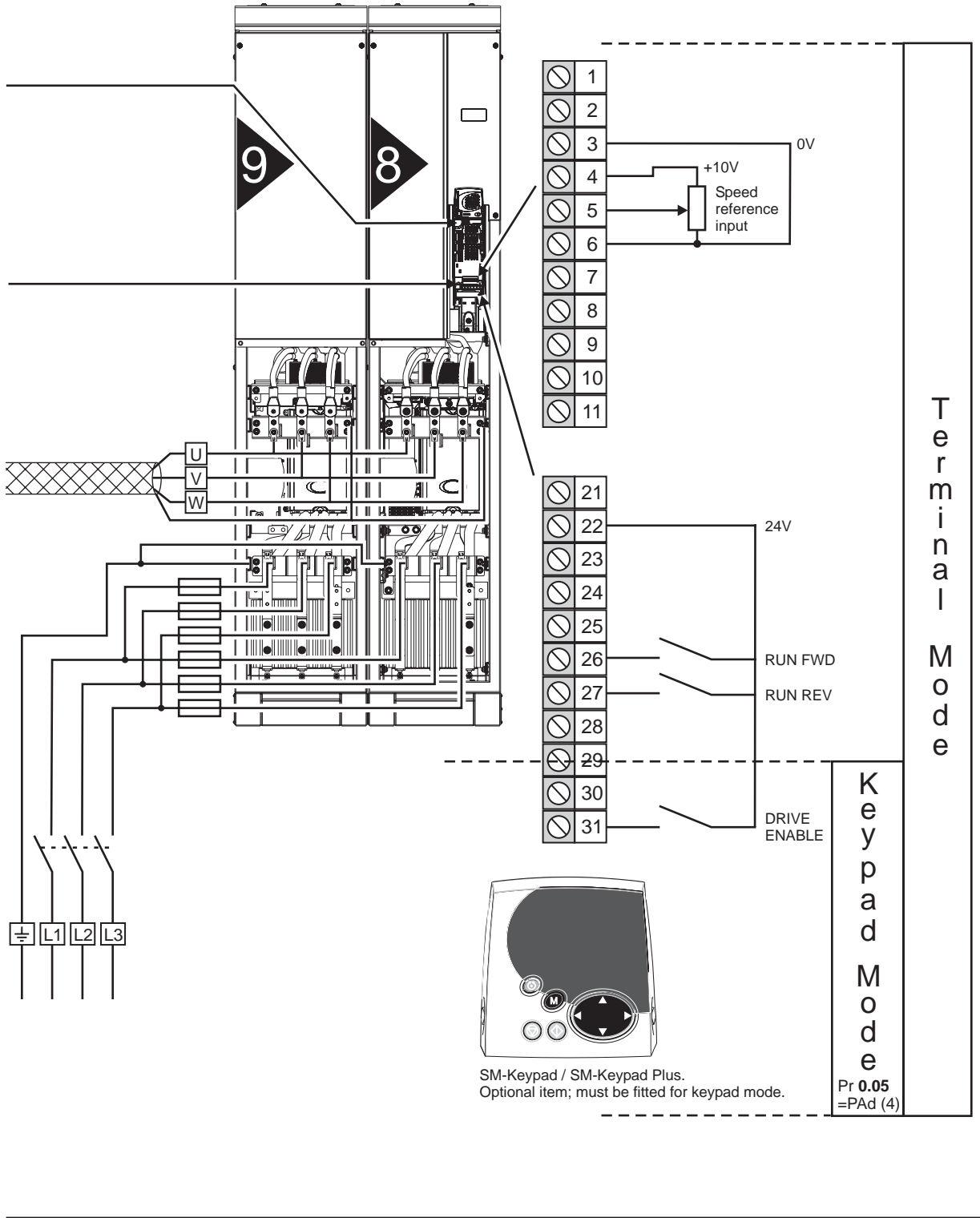
**Figure 7-1 Minimum connections to get the motor running in any operating mode for sizes 1 to 6**





**Figure 7-2 Minimum connections to get the motor running in any operating mode for free standing cubicle drives**







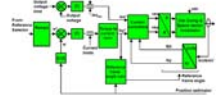
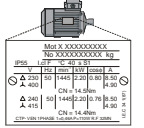

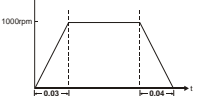

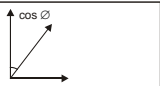
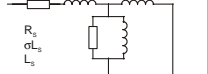
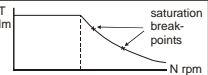


## 7.3 Quick Start commissioning

### 7.3.1 Open loop

| Action                                    | Detail   |   |                  |  |                  |  |      |       |             |          |              |    |      |                |               |  |  |      |             |  |  |  |              |    |      |                |               |  |  |      |             |  |  |  |   |  |  |  |
|---|--|---|------------------|--|------------------|--|------|-------|-------------|----------|--------------|----|------|----------------|---------------|--|--|------|-------------|--|--|--|--------------|----|------|----------------|---------------|--|--|------|-------------|--|--|--|---|--|--|--|
| Before power-up                           | <p>Ensure:</p> <ul style="list-style-type: none"> <li>The drive enable signal is not given (terminal 31)</li> <li>Run signal is not given</li> <li>Motor is connected</li> </ul>   |   |                  |  |                  |  |      |       |             |          |              |    |      |                |               |  |  |      |             |  |  |  |              |    |      |                |               |  |  |      |             |  |  |  |   |  |  |  |
| Power-up the drive                        | <p>Ensure:</p> <ul style="list-style-type: none"> <li>Drive displays 'inh'</li> </ul> <p>If the drive trips, see Chapter 13 <i>Diagnostics</i> on page 275.</p>  |   |                  |  |                  |  |      |       |             |          |              |    |      |                |               |  |  |      |             |  |  |  |              |    |      |                |               |  |  |      |             |  |  |  |   |  |  |  |
| Enter motor nameplate details             | <p>Enter:</p> <ul style="list-style-type: none"> <li>Motor rated frequency in Pr <b>0.47</b> (Hz)</li> <li>Motor rated current in Pr <b>0.46</b> (A)</li> <li>Motor rated speed in Pr <b>0.45</b> (rpm)</li> <li>Motor rated voltage in Pr <b>0.44</b> (V) - check if <math>\Delta</math> or <math>\lambda</math> connection</li> </ul>  | <table border="1"> <tr> <td colspan="2">Mot X XXXXXXXXXX</td> <td colspan="2">No XXXXXXXXXX kg</td> </tr> <tr> <td>IP55</td> <td>I.e.F</td> <td><math>\sim</math>C 40</td> <td><math>\pm</math>S1</td> </tr> <tr> <td><math>\Delta</math> 230</td> <td>50</td> <td>1445</td> <td>2.20 0.80 8.50</td> </tr> <tr> <td><math>\lambda</math> 400</td> <td></td> <td></td> <td>4.90</td> </tr> <tr> <td colspan="4">CN = 14.5Nm</td> </tr> <tr> <td><math>\Delta</math> 240</td> <td>50</td> <td>1445</td> <td>2.20 0.76 8.50</td> </tr> <tr> <td><math>\lambda</math> 415</td> <td></td> <td></td> <td>4.90</td> </tr> <tr> <td colspan="4">CN = 14.4Nm</td> </tr> <tr> <td colspan="4">CTP- VEN 1PHASE I=0.45A P=110W R.F. 32MIN</td> </tr> </table> | Mot X XXXXXXXXXX |  | No XXXXXXXXXX kg |  | IP55 | I.e.F | $\sim$ C 40 | $\pm$ S1 | $\Delta$ 230 | 50 | 1445 | 2.20 0.80 8.50 | $\lambda$ 400 |  |  | 4.90 | CN = 14.5Nm |  |  |  | $\Delta$ 240 | 50 | 1445 | 2.20 0.76 8.50 | $\lambda$ 415 |  |  | 4.90 | CN = 14.4Nm |  |  |  | CTP- VEN 1PHASE I=0.45A P=110W R.F. 32MIN |  |  |  |
| Mot X XXXXXXXXXX                          |  | No XXXXXXXXXX kg  |                  |  |                  |  |      |       |             |          |              |    |      |                |               |  |  |      |             |  |  |  |              |    |      |                |               |  |  |      |             |  |  |  |   |  |  |  |
| IP55                                      | I.e.F  | $\sim$ C 40   | $\pm$ S1         |  |                  |  |      |       |             |          |              |    |      |                |               |  |  |      |             |  |  |  |              |    |      |                |               |  |  |      |             |  |  |  |   |  |  |  |
| $\Delta$ 230                              | 50   | 1445  | 2.20 0.80 8.50   |  |                  |  |      |       |             |          |              |    |      |                |               |  |  |      |             |  |  |  |              |    |      |                |               |  |  |      |             |  |  |  |   |  |  |  |
| $\lambda$ 400                             |  |   | 4.90             |  |                  |  |      |       |             |          |              |    |      |                |               |  |  |      |             |  |  |  |              |    |      |                |               |  |  |      |             |  |  |  |   |  |  |  |
| CN = 14.5Nm                               |  |   |                  |  |                  |  |      |       |             |          |              |    |      |                |               |  |  |      |             |  |  |  |              |    |      |                |               |  |  |      |             |  |  |  |   |  |  |  |
| $\Delta$ 240                              | 50   | 1445  | 2.20 0.76 8.50   |  |                  |  |      |       |             |          |              |    |      |                |               |  |  |      |             |  |  |  |              |    |      |                |               |  |  |      |             |  |  |  |   |  |  |  |
| $\lambda$ 415                             |  |   | 4.90             |  |                  |  |      |       |             |          |              |    |      |                |               |  |  |      |             |  |  |  |              |    |      |                |               |  |  |      |             |  |  |  |   |  |  |  |
| CN = 14.4Nm                               |  |   |                  |  |                  |  |      |       |             |          |              |    |      |                |               |  |  |      |             |  |  |  |              |    |      |                |               |  |  |      |             |  |  |  |   |  |  |  |
| CTP- VEN 1PHASE I=0.45A P=110W R.F. 32MIN |  |   |                  |  |                  |  |      |       |             |          |              |    |      |                |               |  |  |      |             |  |  |  |              |    |      |                |               |  |  |      |             |  |  |  |   |  |  |  |
| Set maximum frequency                     | <p>Enter:</p> <ul style="list-style-type: none"> <li>Maximum frequency in Pr <b>0.02</b> (Hz)</li> </ul>   |   |                  |  |                  |  |      |       |             |          |              |    |      |                |               |  |  |      |             |  |  |  |              |    |      |                |               |  |  |      |             |  |  |  |   |  |  |  |
| Set acceleration / deceleration rates     | <p>Enter:</p> <ul style="list-style-type: none"> <li>Acceleration rate in Pr <b>0.03</b> (s/100Hz)</li> <li>Deceleration rate in Pr <b>0.04</b> (s/100Hz) (If braking resistor fitted, set Pr <b>0.15</b> = FAST. Also ensure Pr <b>10.30</b> and Pr <b>10.31</b> are set correctly, otherwise premature 'lt.br' trips may be seen.)</li> </ul>  |   |                  |  |                  |  |      |       |             |          |              |    |      |                |               |  |  |      |             |  |  |  |              |    |      |                |               |  |  |      |             |  |  |  |   |  |  |  |
| Autotune                                  | <p>Unidrive SP is able to perform either a stationary or a rotating autotune. The motor must be at a standstill before an autotune is enabled. A rotating autotune should be used whenever possible so the measured value of power factor of the motor is used by the drive.</p> <div style="border: 1px solid black; padding: 5px;"> <p> <b>WARNING</b></p> <p>A rotating autotune will cause the motor to accelerate up to <math>\frac{2}{3}</math> base speed in the direction selected regardless of the reference provided. Once complete the motor will coast to a stop. The run signal must be removed before the drive can be made to run at the required reference. The drive can be stopped at any time by removing the run signal or removing the drive enable.</p> </div> <ul style="list-style-type: none"> <li>A stationary autotune can be used when the motor is loaded and it is not possible to uncouple the load from the motor shaft. A stationary autotune measures the stator resistance of the motor and the voltage offset in the drive. These are required for good performance in vector control modes. A stationary autotune does not measure the power factor of the motor so the value on the motor nameplate must be entered into Pr <b>0.43</b>.</li> <li>A rotating autotune should only be used if the motor is uncoupled. A rotating autotune first performs a stationary autotune before rotating the motor at <math>\frac{2}{3}</math> base speed in the direction selected. The rotating autotune measures the power factor of the motor.</li> </ul> <p>To perform an autotune:</p> <ul style="list-style-type: none"> <li>Set Pr <b>0.40</b> = 1 for a stationary autotune or set Pr <b>0.40</b> = 2 for a rotating autotune</li> <li>Close the Drive Enable signal (terminal 31). The drive will display 'rdY'.</li> <li>Close the run signal (terminal 26 or 27). The lower display will flash 'Auto' and 'tunE' alternatively, while the drive is performing the autotune.</li> <li>Wait for the drive to display 'rdY' or 'inh' and for the motor to come to a standstill.</li> </ul> <p>If the drive trips, see Chapter 13 <i>Diagnostics</i> on page 275.<br/>Remove the drive enable and run signal from the drive.</p> |   |                  |  |                  |  |      |       |             |          |              |    |      |                |               |  |  |      |             |  |  |  |              |    |      |                |               |  |  |      |             |  |  |  |   |  |  |  |
| Save parameters                           | <p>Enter 1000 in Pr <b>xx.00</b></p> <p>Press the red  reset button or toggle the reset digital input (ensure Pr <b>xx.00</b> returns to 0)</p>  |   |                  |  |                  |  |      |       |             |          |              |    |      |                |               |  |  |      |             |  |  |  |              |    |      |                |               |  |  |      |             |  |  |  |   |  |  |  |
| Run                                       | Drive is now ready to run  |   |                  |  |                  |  |      |       |             |          |              |    |      |                |               |  |  |      |             |  |  |  |              |    |      |                |               |  |  |      |             |  |  |  |   |  |  |  |

### 7.3.2 RFC mode




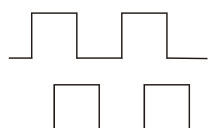
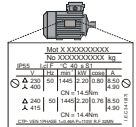
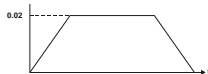
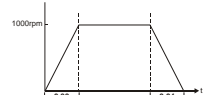

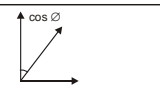
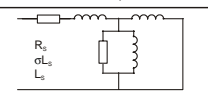
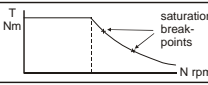


#### Induction motor

| Action  | Detail   |   |
|---|--|---|
| Before power-up                                     | <p>Ensure:</p> <ul style="list-style-type: none"> <li>Drive Enable signal is not given (terminal 31)</li> <li>Run signal is not given</li> <li>Motor and feedback device are connected</li> </ul>  |    |
| Power-up the drive                                  | <p>Ensure:</p> <ul style="list-style-type: none"> <li>Drive displays 'inh'</li> </ul> <p>If the drive trips, see Chapter 13 <i>Diagnostics</i> on page 275.</p>  |    |
| Select RFC mode and disable encoder wire-break trip | <ul style="list-style-type: none"> <li>Set Pr <b>3.24</b> = 1 to select RFC mode</li> <li>Set Pr <b>3.40</b> = 0</li> </ul>  |    |
| Enter motor nameplate details                       | <p>Enter:</p> <ul style="list-style-type: none"> <li>Motor rated frequency in Pr <b>0.47</b> (Hz)</li> <li>Motor rated current in Pr <b>0.46</b> (A)</li> <li>Motor rated speed (base speed - slip speed) in Pr <b>0.45</b> (rpm)</li> <li>Motor rated voltage in Pr <b>0.44</b> (V) - check if <math>\Delta</math> or <math>\text{Y}</math> connection</li> </ul>   |    |
| Set maximum speed                                   | <p>Enter:</p> <ul style="list-style-type: none"> <li>Maximum speed in Pr <b>0.02</b> (rpm)</li> </ul>  |    |
| Set acceleration / deceleration rates               | <p>Enter:</p> <ul style="list-style-type: none"> <li>Acceleration rate in Pr <b>0.03</b> (s/1000rpm)</li> <li>Deceleration rate in Pr <b>0.04</b> (s/1000rpm) (If braking resistor fitted, set Pr <b>0.15</b> = FAST. Also ensure Pr <b>10.30</b> and Pr <b>10.31</b> are set correctly, otherwise premature 'lt.br' trips may be seen.)</li> </ul>  |    |
| Autotune  | <p>Unidrive SP is able to perform either a stationary or a rotating autotune. The motor must be at a standstill before an autotune is enabled. A stationary autotune will give moderate performance whereas a rotating autotune will give improved performance as it measures the actual values of the motor parameters required by the drive.</p> <div style="border: 1px solid black; padding: 5px;">  <p>A rotating autotune will cause the motor to accelerate up to <math>\frac{2}{3}</math> base speed in the direction selected regardless of the reference provided. Once complete the motor will coast to a stop. The run signal must be removed before the drive can be made to run at the required reference.</p> <p><b>WARNING</b> The drive can be stopped at any time by removing the run signal or removing the drive enable.</p> </div> <ul style="list-style-type: none"> <li>A stationary autotune can be used when the motor is loaded and it is not possible to uncouple the load from the motor shaft. The stationary autotune measures the stator resistance and transient inductance of the motor. These are used to calculate the current loop gains, and at the end of the test the values in Pr <b>0.38</b> and Pr <b>0.39</b> are updated. A stationary autotune does not measure the power factor of the motor so the value on the motor nameplate must be entered into Pr <b>0.43</b>.</li> <li>A rotating autotune should only be used if the motor is uncoupled. A rotating autotune first performs a stationary autotune before rotating the motor at <math>\frac{2}{3}</math> base speed in the direction selected. The rotating autotune measures the stator inductance of the motor and calculates the power factor.</li> </ul> <p>To perform an autotune:</p> <ul style="list-style-type: none"> <li>Set Pr <b>0.40</b> = 1 for a stationary autotune or set Pr <b>0.40</b> = 2 for a rotating autotune</li> <li>Close the Drive Enable signal (terminal 31). The drive will display 'rdY'</li> <li>Close the run signal (terminal 26 or 27). The lower display will flash 'Auto' and 'tunE' alternatively, while the drive is performing the autotune.</li> <li>Wait for the drive to display 'rdY' or 'inh' and for the motor to come to a standstill</li> </ul> <p>If the drive trips, see Chapter 13 <i>Diagnostics</i> on page 275.</p> <p>Remove the drive enable and run signal from the drive.</p> |    |
| Save parameters                                     | <p>Enter 1000 in Pr <b>xx.00</b></p> <p>Press the red  reset button or toggle the reset digital input (ensure Pr <b>xx.00</b> returns to 0)</p>   |   |
| Run   | Drive is now ready to run  |    |

### 7.3.3 Closed loop vector mode

#### Induction motor with incremental encoder feedback




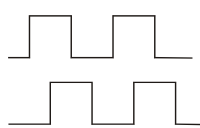
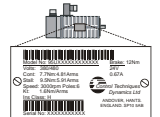
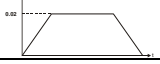
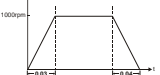

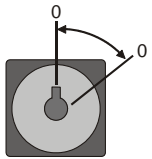


For simplicity only an incremental quadrature encoder will be considered here. For information on setting up one of the other supported speed feedback devices, refer to section 7.5 *Setting up a feedback device* on page 134.

| Action                                | Detail  |   |
|---------------------------------------|---|---|
| Before power-up                       | Ensure: <ul style="list-style-type: none"> <li>Drive Enable signal is not given (terminal 31)</li> <li>Run signal is not given</li> <li>Motor and feedback device are connected</li> </ul>  |    |
| Power-up the drive                    | Ensure: <ul style="list-style-type: none"> <li>Drive displays 'inh'</li> </ul> If the drive trips, see Chapter 13 <i>Diagnostics</i> on page 275.   |    |
| Set motor feedback parameters         | <b>Incremental encoder basic set-up</b><br>Enter: <ul style="list-style-type: none"> <li>Drive encoder type in Pr <b>3.38</b> = Ab (0): Quadrature encoder</li> <li>Encoder power supply in Pr <b>3.36</b> = 5V (0), 8V (1) or 15V (2).</li> </ul> <b>NOTE</b> If Ab encoder voltage is greater than 5V, then the termination resistors must be disabled Pr <b>3.39</b> to 0. <div style="border: 1px solid black; padding: 5px; margin: 5px 0;">            Setting the encoder voltage supply too high for the encoder could result in damage to the feedback device. </div> <b>CAUTION</b> <ul style="list-style-type: none"> <li>Drive encoder Lines Per Revolution (LPR) in Pr <b>3.34</b> (set according to encoder)</li> <li>Drive encoder termination resistor setting in Pr <b>3.39</b>: <ul style="list-style-type: none"> <li>0 = A-A\, B-B\, Z-Z\ termination resistors disabled</li> <li>1 = A-A\, B-B\, termination resistors enabled, Z-Z\ termination resistors disabled</li> <li>2 = A-A\, B-B\, Z-Z\ termination resistors enabled</li> </ul> </li> </ul>  |    |
| Enter motor nameplate details         | Enter: <ul style="list-style-type: none"> <li>Motor rated frequency in Pr <b>0.47</b> (Hz)</li> <li>Motor rated current in Pr <b>0.46</b> (A)</li> <li>Motor rated speed (base speed - slip speed) in Pr <b>0.45</b> (rpm)</li> <li>Motor rated voltage in Pr <b>0.44</b> (V) - check if <math>\Delta</math> or <math>\text{Y}</math> connection</li> </ul>   |    |
| Set maximum speed                     | Enter: <ul style="list-style-type: none"> <li>Maximum speed in Pr <b>0.02</b> (rpm)</li> </ul>  |    |
| Set acceleration / deceleration rates | Enter: <ul style="list-style-type: none"> <li>Acceleration rate in Pr <b>0.03</b> (s/1000rpm)</li> <li>Deceleration rate in Pr <b>0.04</b> (s/1000rpm) (If braking resistor fitted, set Pr <b>0.15</b> = FAST. Also ensure Pr <b>10.30</b> and Pr <b>10.31</b> are set correctly, otherwise premature 'lt.br' trips may be seen.)</li> </ul>  |    |
| Autotune                              | Unidrive SP is able to perform either a stationary or a rotating autotune. The motor must be at a standstill before an autotune is enabled. A stationary autotune will give moderate performance whereas a rotating autotune will give improved performance as it measures the actual values of the motor parameters required by the drive. <div style="border: 1px solid black; padding: 5px; margin: 5px 0;">            A rotating autotune will cause the motor to accelerate up to <math>\frac{2}{3}</math> base speed in the direction selected regardless of the reference provided. Once complete the motor will coast to a stop. The run signal must be removed before the drive can be made to run at the required reference. </div> <b>WARNING</b> The drive can be stopped at any time by removing the run signal or removing the drive enable. <ul style="list-style-type: none"> <li>A stationary autotune can be used when the motor is loaded and it is not possible to uncouple the load from the motor shaft. The stationary autotune measures the stator resistance and transient inductance of the motor. These are used to calculate the current loop gains, and at the end of the test the values in Pr <b>0.38</b> and Pr <b>0.39</b> are updated. A stationary autotune does not measure the power factor of the motor so the value on the motor nameplate must be entered into Pr <b>0.43</b>.</li> <li>A rotating autotune should only be used if the motor is uncoupled. A rotating autotune first performs a stationary autotune before rotating the motor at <math>\frac{2}{3}</math> base speed in the direction selected. The rotating autotune measures the stator inductance of the motor and calculates the power factor.</li> </ul> To perform an autotune: <ul style="list-style-type: none"> <li>Set Pr <b>0.40</b> = 1 for a stationary autotune or set Pr <b>0.40</b> = 2 for a rotating autotune</li> <li>Close the Drive Enable signal (terminal 31). The drive will display 'rdY'</li> <li>Close the run signal (terminal 26 or 27). The lower display will flash 'Auto' and 'tunE' alternatively, while the drive is performing the autotune.</li> <li>Wait for the drive to display 'rdY' or 'inh' and for the motor to come to a standstill</li> </ul> If the drive trips, see Chapter 13 <i>Diagnostics</i> on page 275.<br>Remove the drive enable and run signal from the drive. |    |
| Save parameters                       | Enter 1000 in Pr <b>xx.00</b><br>Press the red  reset button or toggle the reset digital input (ensure Pr <b>xx.00</b> returns to 0)   |   |
| Run                                   | Drive is now ready to run   |    |

### 7.3.4 Servo

#### Permanent magnet motor with a speed and position feedback device

For simplicity only an incremental quadrature encoder with commutation outputs will be considered here. For information on setting up one of the other supported speed feedback devices, refer to section 7.5 *Setting up a feedback device* on page 134.

| Action                                | Detail  |   |
|---------------------------------------|---|---|
| Before power-up                       | Ensure: <ul style="list-style-type: none"> <li>Drive Enable signal is not given (terminal 31)</li> <li>Run signal is not given</li> <li>Motor is connected</li> <li>Feedback device is connected</li> </ul>   |    |
| Power-up the drive                    | Ensure: <ul style="list-style-type: none"> <li>Drive displays 'inh'</li> </ul> If the drive trips, see Chapter 13 <i>Diagnostics</i> on page 275.   |    |
| Set motor feedback parameters         | <b>Incremental encoder basic set-up</b><br>Enter: <ul style="list-style-type: none"> <li>Drive encoder type in Pr. <b>3.38</b> = Ab.SERVO (3): Quadrature encoder with commutation outputs</li> <li>Encoder power supply in Pr. <b>3.36</b> = 5V (0), 8V (1) or 15V (2).</li> </ul> <b>NOTE</b> If Ab encoder voltage is greater than 5V, then the termination resistors must be disabled Pr <b>3.39</b> to 0. <div style="border: 1px solid black; padding: 5px; margin-top: 10px;">  Setting the encoder voltage supply too high for the encoder could result in damage to the feedback device. </div> <ul style="list-style-type: none"> <li>Drive encoder Pulses Per Revolution in Pr. <b>3.34</b> (set according to encoder)</li> <li>Drive encoder termination resistor setting in Pr. <b>3.39</b>: <ul style="list-style-type: none"> <li>0 = A-A, B-B, Z-Z termination resistors disabled</li> <li>1 = A-A, B-B, termination resistors enabled, Z-Z termination resistors disabled</li> <li>2 = A-A, B-B, Z-Z termination resistors enabled</li> </ul> </li> </ul>   |    |
| Enter motor nameplate details         | Enter: <ul style="list-style-type: none"> <li>Motor rated current in Pr <b>0.46</b> (A)</li> <li>Ensure that this equal to or less than the Heavy Duty rating of the drive otherwise It.AC trips may occur during the autotune.</li> <li>Number of poles in Pr <b>0.42</b></li> </ul>   |    |
| Set maximum speed                     | Enter: <ul style="list-style-type: none"> <li>Maximum speed in Pr <b>0.02</b> (rpm)</li> </ul>  |   |
| Set acceleration / deceleration rates | Enter: <ul style="list-style-type: none"> <li>Acceleration rate in Pr <b>0.03</b> (s/1000rpm)</li> <li>Deceleration rate in Pr <b>0.04</b> (s/1000rpm) (If braking resistor fitted, set Pr <b>0.15</b> = FAST. Also ensure Pr <b>10.30</b> and Pr <b>10.31</b> are set correctly, otherwise premature 'lt.br' trips may be seen.)</li> </ul>  |  |
| Autotune                              | Unidrive SP is able to perform a short low speed, a normal low speed or a minimal movement autotune. The motor must be at a standstill before an autotune is enabled. A normal low speed autotune will measure the encoder phase offset angle and calculate the current gains. <div style="border: 1px solid black; padding: 5px; margin-top: 10px;">  The short low speed and normal low speed tests will rotate the motor by up to 2 revolutions in the direction selected, regardless of the reference provided. The minimal movement test will move the motor through an angle defined by Pr <b>5.38</b>.<br/>           Once complete the motor will come to a standstill. The run signal must be removed before the drive can be made to run at the required reference.<br/>           The drive can be stopped at any time by removing the run signal or removing the Drive Enable. </div> <p>The motor must not be loaded when attempting an autotune.</p> <ul style="list-style-type: none"> <li>The short low speed and normal low speed tests will rotate the motor by up to 2 rotations in the direction selected and the drive measures the encoder phase angle and updates the value in Pr <b>3.25</b>. The normal low speed test also measures the stator resistance, and inductance of the motor. These are used to calculate the current loop gains, and at the end of the test the values in Pr <b>0.38</b> and Pr <b>0.39</b> are updated. The short low speed test takes approximately 2s and the normal low speed test approximately 20s to complete.</li> <li>The minimal movement autotune will move the motor through an angle defined by Pr <b>5.38</b>. The motor must not be loaded for this test although it will operate correctly when the load is an inertia.</li> </ul> <p>To perform an autotune:</p> <ul style="list-style-type: none"> <li>Set Pr <b>0.40</b> = 1 for a short low speed autotune, Pr <b>0.40</b> = 2 for a normal low speed test or Pr <b>0.40</b> = 5 for a minimal movement autotune.</li> <li>Close the run signal (terminal 26 or 27).</li> <li>Close the Drive Enable signal (terminal 31). The lower display will flash 'Auto' and 'tunE' alternatively, while the drive is performing the test.</li> <li>Wait for the drive to display 'rdy' or 'inh' and for the motor to come to a standstill.</li> </ul> <p>If the drive trips it cannot be reset until the drive enable signal (terminal 31) has been removed. See Chapter 13 <i>Diagnostics</i> on page 275.</p> <p>Remove the drive enabled and run signal from the drive.</p> |  |
| Save parameters                       | Enter 1000 in Pr <b>xx.00</b><br>Press the red  reset button or toggle the reset digital input (ensure Pr <b>xx.00</b> returns to 0)   |   |
| Run                                   | Drive is now ready to run   |  |

## 7.4 Quick start commissioning (CTSoft)

CTSoft is a Windows™ based software commissioning tool for Unidrive SP and other Control Techniques products.

CTSoft can be used for commissioning and monitoring, drive parameters can be uploaded, downloaded and compared, and simple or custom menu listings can be created. Drive menus can be displayed in standard list format or as live block diagrams. CTSoft is able to communicate with a single drive or a network.

CTSoft can be found on the CD which is supplied with the drive and is also available for download from [www.controltechniques.com](http://www.controltechniques.com) (file size approximately 60MB).

CTSoft system requirements:

- Windows 98/98SE/ME/NT4/2000/XP. **Windows 95 is NOT supported**
- Internet Explorer V5.0 or later must be installed
- Minimum of 800x600 screen resolution with 256 colours. 1024x768 is recommended.
- 128MB RAM
- Pentium II 266MHz or better recommended.
- Adobe Acrobat Reader 5.1 or later (for parameter help). See Unidrive SP CD provided
- Note that you must have administrator rights under Windows NT/2000/XP to install.

To install CTSoft from the CD, insert the CD and the auto-run facility should start up the front-end screen from which CTSoft can be selected. Any previous copy of CTSoft should be uninstalled before proceeding with the installation (existing projects will not be lost).

Included with CTSoft are the user guides for the supported drive models. When help on a particular parameter is request by the user, CTSoft links to the parameter in the relevant advanced user guide.

## 7.5 Setting up a feedback device

This section shows the parameter settings which must be made to use each of the compatible encoder types with Unidrive SP. For more information on the parameters listed here please refer to the *Unidrive SP Advanced User Guide*.

### 7.5.1 Overview

Table 7-3 Parameters required for feedback device set-up

| Parameter   | Ab, Fd, Fr, Ab.SErVO, Fd.SErVO, Fr.SErVO, or SC encoders | SC.HiPEr encoder | SC.EndAt or SC.SSI encoders | EndAt encoder | SSI encoder |
|---|--|------------------|-----------------------------|---------------|-------------|
| <b>3.33</b> Drive encoder turns   |  | ✓ x              | ✓ x                         | ✓ x           | ✓           |
| <b>3.34</b> Drive encoder lines per revolution                                  | ✓  | ✓ x              | ✓ x                         |               |             |
| <b>3.35</b> Drive encoder comms resolution                                      |  | ✓ x              | ✓ x                         | ✓ x           | ✓           |
| <b>3.36</b> Drive encoder supply voltage*                                       | ✓  | ✓                | ✓                           | ✓             | ✓           |
| <b>3.37</b> Drive encoder comms baud rate                                       |  |                  | ✓                           | ✓             | ✓           |
| <b>3.38</b> Drive encoder type  | ✓  | ✓                | ✓                           | ✓             | ✓           |
| <b>3.41</b> Drive encoder auto configuration enable or SSI binary format select |  | ✓                | ✓                           | ✓             | ✓           |

✓ Information required

x Parameter can be set-up automatically by the drive through auto-configuration

\* Pr 3.36: If A + B >5V then disable termination resistors

Table 7-3 shows a summary of the parameters required to set-up each feedback device. More detailed information follows.

## 7.5.2 Detailed feedback device commissioning information

### Standard quadrature encoder with or without commutation signals (A, B, Z or A, B, Z, U, V, W), or Sincos encoder without serial communications

|   |         |   |
|---|---------|---|
| Encoder type  | Pr 3.38 | Ab (0) for a quadrature encoder without commutation signals *<br>Ab.SERVO (3) for a quadrature encoder with commutation signals<br>SC (6) for a Sincos encoder without serial communications *  |
| Encoder power supply voltage                        | Pr 3.36 | 5V (0), 8V (1) or 15V (2)<br><b>NOTE</b><br>If Ab encoder voltage is greater than 5V, then the termination resistors must be disabled Pr 3.39 to 0  |
| Encoder number of lines per revolution              | Pr 3.34 | Set to the number of lines or sine waves per revolution of the encoder.<br>See section 7.5.3 <i>Restriction of encoder number of lines per revolution</i> on page 137 for restrictions on this parameter.   |
| Encoder termination selection (Ab or Ab.SERVO only) | Pr 3.39 | 0 = A, B, Z termination resistors disabled<br>1 = A, B termination resistors enabled and Z termination resistors disabled<br>2 = A, B, Z termination resistors enabled  |
| Encoder error detection level                       | Pr 3.40 | 0 = Error detection disable<br>1 = Wire break detection on A, B and Z inputs enabled<br>2 = Phase error detection (Ab.SERVO only)<br>3 = Wire break detection on A, B and Z inputs and phase error detection (Ab.SERVO only)<br>Termination resistors must be enabled for wire break detection to operate |

\* These settings should only be used in closed loop vector mode, otherwise a phase offset test must be performed after every power up.

### Incremental encoder with frequency and direction (F and D), or Forward and Reverse (CW and CCW) signals, with or without commutation signals

|  |         |   |
|--|---------|---|
| Encoder type                           | Pr 3.38 | Fd (1) for frequency and direction signals without commutation signals *<br>Fr (2) for forward and reverse signals without commutation signals *<br>Fd.SERVO (4) for a frequency and direction encoder with commutation signals<br>Fr.SERVO (5) for forward and reverse signals with commutation signals  |
| Encoder power supply voltage           | Pr 3.36 | 5V (0), 8V (1) or 15V (2)<br><b>NOTE</b><br>If Ab encoder voltage is greater than 5V, then the termination resistors must be disabled Pr 3.39 to 0  |
| Encoder number of lines per revolution | Pr 3.34 | Set to the number of pulses per revolution of the encoder divide by 2.<br>See section 7.5.3 <i>Restriction of encoder number of lines per revolution</i> on page 137 for restrictions on this parameter.  |
| Encoder termination selection          | Pr 3.39 | 0 = F or CW, D or CCW, Z termination resistors disabled<br>1 = F or CW, D or CCW termination resistors enabled and Z termination resistors disabled<br>2 = For CW, D or CCW, Z termination resistors enabled  |
| Encoder error detection level          | Pr 3.40 | 0 = Error detection disable<br>1 = Wire break detection on F & D or CW & CCW, and Z inputs enabled<br>2 = Phase error detection (Fd.SERVO and Fr.SERVO only)<br>3 = Wire break detection on F & D or CW & CCW, and Z inputs and Phase error detection (Fd.SERVO and Fr.SERVO only)<br>Termination resistors must be enabled for wire break detection to operate |

\* These settings should only be used in closed loop vector mode, otherwise a phase offset test must be performed after every power up.

### Absolute Sincos encoder with Hiperface or EnDat serial communications, or Absolute EnDat communications only encoder

The Unidrive SPM is compatible with the following Hiperface encoders:

SCS 60/70, SCM 60/70, SRS 50/60, SRM 50/60, SHS 170, LINCODER, SCS-KIT 101, SKS36, SKM36, SEK-53.

|  |         |   |
|--|---------|---|
| Encoder type   | Pr 3.38 | <b>SC.HiPEr</b> (7) for a Sincos encoder with Hiperface serial communications<br><b>EndAt</b> (8) for an EnDat communications only encoder<br><b>SC.EndAt</b> (9) for a Sincos encoder with EnDat serial communications   |
| Encoder power supply voltage                               | Pr 3.36 | <b>5V</b> (0), <b>8V</b> (1) or <b>15V</b> (2)  |
| Encoder auto configure enable                              | Pr 3.41 | Setting this to 1 automatically sets up the following parameters:<br>Pr 3.33 Encoder turn bits<br>Pr 3.34 Encoder number of lines of revolution (SC.HiPEr and SC.EndAt only) *<br>Pr 3.35 Encoder single turn comms resolution<br>Alternatively these parameters can be entered manually. |
| Encoder comms baud rate (EndAt and SC.EndAt only)          | Pr 3.37 | <b>100</b> = 100k, <b>200</b> = 200k, <b>300</b> = 300k, <b>500</b> = 500k, <b>1000</b> = 1M, <b>1500</b> = 1.5M, or <b>2000</b> = 2M   |
| Encoder error detection level (SC.HiPEr and SC.EndAt only) | Pr 3.40 | <b>0</b> = Error detection disabled<br><b>1</b> = Wire break detection on Sin and Cos inputs<br><b>2</b> = Phase error detection<br><b>3</b> = Wire break detection on Sin and Cos inputs and phase error detection   |

\* See section 7.5.3 *Restriction of encoder number of lines per revolution* on page 137 for restrictions on this parameter.

### Absolute SSI communications only encoder, or Absolute Sincos encoder with SSI

|   |         |  |
|---|---------|--|
| Encoder type  | Pr 3.38 | <b>SSI</b> (10) for a SSI communications only encoder<br><b>SC.SSI</b> (11) for a Sincos encoder with SSI  |
| Encoder power supply voltage                          | Pr 3.36 | <b>5V</b> (0), <b>8V</b> (1) or <b>15V</b> (2)<br><b>NOTE</b><br>If Ab encoder voltage is greater than 5V, then the termination resistors must be disabled Pr 3.39 to 0  |
| Encoder number of lines per revolution. (SC.SSI only) | Pr 3.34 | Set to the number of sine waves per revolution of the encoder.<br>See section 7.5.3 <i>Restriction of encoder number of lines per revolution</i> on page 137 for restrictions on this parameter.   |
| SSI binary format select                              | Pr 3.41 | <b>OFF</b> (0) for gray code, or <b>On</b> (1) for binary format SSI encoders  |
| Encoder turn bits                                     | Pr 3.33 | Set to the number of turn bits for the encoder (this is usually 12bits for a SSI encoder)  |
| Encoder single turn comms resolution                  | Pr 3.35 | Set to the single turn comms resolution for the encoder (this is usually 13bits for a SSI encoder)   |
| Encoder comms baud rate                               | Pr 3.37 | <b>100</b> = 100k, <b>200</b> = 200k, <b>300</b> = 300k, <b>500</b> = 500k, <b>1000</b> = 1M, <b>1500</b> = 1.5M, or <b>2000</b> = 2M  |
| Encoder error detection level                         | Pr 3.40 | <b>0</b> = Error detection disabled<br><b>1</b> = Wire break detection on Sin and Cos inputs (SC.SSI only)<br><b>2</b> = Phase error detection (SC.SSI only)<br><b>3</b> = Wire break detection and phase error detection (SC.SSI only)<br><b>4</b> = SSI power supply bit monitor<br><b>5</b> = SSI power supply bit monitor and wire break detection (SC.SSI only)<br><b>6</b> = SSI power supply bit monitor and phase error detection (SC.SSI only)<br><b>7</b> = SSI power supply bit monitor, wire break detection and phase error detection (SC.SSI only) |

### UVW commutation signal only encoders\*

|  |         |  |
|--|---------|--|
| Encoder type                           | Pr 3.38 | Ab.servo                                       |
| Encoder power supply voltage           | Pr 3.36 | <b>5V</b> (0), <b>8V</b> (1) or <b>15V</b> (2) |
| Encoder number of lines per revolution | Pr 3.34 | Set to zero                                    |
| Encoder error detection level          | Pr 3.40 | Set to zero to disable wire break detection    |

\* This feedback device provides very low resolution feedback and should not be used for applications requiring a high level of performance.

### 7.5.3 Restriction of encoder number of lines per revolution

Although Pr 3.34 can be set to any value from 0 to 50,000 there are restrictions on the values actually used by the drive. These restrictions are dependent on the software version as follows:

#### Software version V01.06.01 and later

Table 7-4 Restrictions of drive encoder lines per revolution with software version V01.06.01 and later

| Position feedback device                     | Equivalent Lines per revolution used by the drive   |
|--|---|
| Ab, Fd, Fr, Ab.SErVO, Fd.SErVO, Fr.SErVO, SC | The drive uses the value in Pr 3.34.  |
| SC.HiPEr, SC.EndAt, SC.SSI (rotary encoders) | If Pr 3.34 $\leq 1$ , the drive uses the value of 1.<br>If $1 < \text{Pr } 3.34 < 32,768$ , the drive uses the value in Pr 3.34 rounded down to nearest value that is a power of 2.<br>If Pr 3.34 $\geq 32,768$ , the drive uses the value of 32,768. |
| SC.HiPEr, SC.EndAt, SC.SSI (linear encoders) | The drive uses the value in Pr 3.34.  |

#### Software version V01.06.00 and earlier

Table 7-5 Restrictions of drive encoder lines per revolution with software version V01.06.00 and earlier

| Position feedback device       | Equivalent Lines per revolution used by the drive   |
|--------------------------------|---|
| Ab, Fd, Fr                     | If Pr 3.34 $< 2$ , the drive uses the value of 2.<br>If $2 \leq \text{Pr } 3.34 \leq 16,384$ , the drive uses the value in Pr 3.34.<br>If Pr 3.34 $> 16,384$ , the drive uses the value in Pr 3.34 rounded down to nearest value divisible by 4.      |
| Ab.SErVO, Fd.SErVO, Fr.SErVO   | If Pr 3.34 $\leq 2$ , the drive uses the value of 2.<br>If $2 < \text{Pr } 3.34 < 16,384$ , the drive uses the value in Pr 3.34 rounded down to nearest value that is a power of 2.<br>If Pr 3.34 $\geq 16,384$ , the drive uses the value of 16,384. |
| SC, SC.HiPEr, SC.EndAt, SC.SSI | If Pr 3.34 $\leq 2$ , the drive uses the value of 2.<br>If $2 < \text{Pr } 3.34 < 32,768$ , the drive uses the value in Pr 3.34 rounded down to nearest value that is a power of 2.<br>If Pr 3.34 $\geq 32,768$ , the drive uses the value of 32,768. |

At power-up Pr 3.48 is initially zero, but is set to one when the drive encoder and any encoders connected to any Solutions Modules have been initialised. The drive cannot be enabled until this parameter is one.

Encoder initialisation will occur as follows:

- At drive power-up
- When requested by the user via Pr 3.47
- When trips PS.24V, Enc1 to Enc8, or Enc11 to Enc17 trips are reset
- The encoder number of lines per revolution (Pr 3.34) or the number of motor poles (Pr 5.11 and Pr 21.11) are changed (software version V01.08.00 and later).

Initialisation causes an encoder with communications to be re-initialised and auto-configuration to be performed if selected. After initialisation Ab.SErVO, Fd.SErVO and Fr.SErVO encoders will use the UVW commutations signals to give position feedback for the first 120° (electrical) of rotation when the motor is restarted.

## 8 Optimisation

This chapter takes the user through methods of optimising the product set-up, maximising performance. The auto-tuning features of the drive simplify this task.

### 8.1 Motor map parameters

#### 8.1.1 Open loop motor control

|  |  |
|--|--|
| <b>Pr 0.46 {5.07} Motor rated current</b>  | <b>Defines the maximum continuous motor current</b>                |
| <p>The motor rated current parameter must be set to the maximum continuous current of the motor. (See section 8.2 <i>Maximum motor rated current</i> on page 148, for information about setting this parameter higher than the maximum Heavy Duty current rating.) The motor rated current is used in the following:</p> <ul style="list-style-type: none"> <li>• Current limits (see section 8.3 <i>Current limits</i> on page 148, for more information)</li> <li>• Motor thermal overload protection (see section 8.4 <i>Motor thermal protection</i> on page 148, for more information)</li> <li>• Vector mode voltage control (see Voltage mode Pr <b>0.07</b>, later in this table)</li> <li>• Slip compensation (see Slip compensation Pr <b>5.27</b>, later in this table)</li> <li>• Dynamic V/F control</li> </ul>   |  |
| <b>Pr 0.44 {5.09} Motor rated voltage</b>  | <b>Defines the voltage applied to the motor at rated frequency</b> |
| <b>Pr 0.47 {5.06} Motor rated frequency</b>  | <b>Defines the frequency at which rated voltage is applied</b>     |
| <p>The motor rated voltage Pr <b>0.44</b> and the motor rated frequency Pr <b>0.47</b> are used to define the voltage to frequency characteristic applied to the motor (see voltage mode Pr <b>0.07</b>, later in this table). The motor rated frequency is also used in conjunction with the motor rated speed to calculate the rated slip for slip compensation (see motor rated speed Pr <b>0.45</b>, later in this table).</p>   |  |
| <p>The graph shows 'Output voltage' on the y-axis and 'Output frequency' on the x-axis. A line starts at the origin, passes through the point (Pr 0.47 / 2, Pr 0.44 / 2), and ends at (Pr 0.47, Pr 0.44). After Pr 0.47, the output voltage remains constant at Pr 0.44.</p>   |  |
| <b>Pr 0.45 {5.08} Motor rated speed</b>  | <b>Defines the full load rated speed of the motor</b>              |
| <b>Pr 0.42 {5.11} Motor number of poles</b>  | <b>Defines the number of motor poles</b>                           |
| <p>The motor rated speed and the number of poles are used with the motor rated frequency to calculate the rated slip of induction machines in Hz.</p> $\text{Rated slip (Hz)} = \text{Motor rated frequency} - (\text{Number of pole pairs} \times [\text{Motor rated speed} / 60]) = 0.47 - \left( \frac{0.42}{2} \times \frac{0.45}{60} \right)$ <p>If Pr <b>0.45</b> is set to 0 or to synchronous speed, slip compensation is disabled. If slip compensation is required this parameter should be set to the nameplate value, which should give the correct rpm for a hot machine. Sometimes it will be necessary to adjust this when the drive is commissioned because the nameplate value may be inaccurate. Slip compensation will operate correctly both below base speed and within the field-weakening region. Slip compensation is normally used to correct for the motor speed to prevent speed variation with load. The rated load rpm can be set higher than synchronous speed to deliberately introduce speed droop. This can be useful to aid load sharing with mechanically coupled motors.</p> <p>Pr <b>0.42</b> is also used in the calculation of the motor speed display by the drive for a given output frequency. When Pr <b>0.42</b> is set to 'Auto', the number of motor poles is automatically calculated from the rated frequency Pr <b>0.47</b>, and the motor rated speed Pr <b>0.45</b>.</p> $\text{Number of poles} = 120 \times (\text{Motor rated frequency Pr } 0.47 / \text{Motor rated speed Pr } 0.45) \text{ rounded to the nearest even number}$   |  |
| <b>Pr 0.43 {5.10} Motor rated power factor</b>   | <b>Defines the angle between the motor voltage and current</b>     |
| <p>The power factor is the true power factor of the motor, i.e. the angle between the motor voltage and current. The power factor is used in conjunction with the motor rated current Pr <b>0.46</b>, to calculate the rated active current and magnetising current of the motor. The rated active current is used extensively to control the drive, and the magnetising current is used in vector mode stator resistance compensation. It is important that this parameter is set up correctly. The drive can measure the motor rated power factor by performing a rotating autotune (see Autotune Pr <b>0.40</b>, below).</p>  |  |
| <b>Pr 0.40 {5.12} Autotune</b>   |  |
| <p>There are two autotune tests available in open loop mode, a stationary and a rotating test. A rotating autotune should be used whenever possible so the measured value of power factor of the motor is used by the drive.</p> <ul style="list-style-type: none"> <li>• A stationary autotune can be used when the motor is loaded and it is not possible to remove the load from the motor shaft. The stationary test measures the stator resistance (Pr <b>5.17</b>) and voltage offset (Pr <b>5.23</b>), which are required for good performance in vector control modes (see Voltage mode Pr <b>0.07</b>, later in this table). The stationary autotune does not measure the power factor of the motor so the value on the motor nameplate must be entered into Pr <b>0.43</b>. To perform a Stationary autotune, set Pr <b>0.40</b> to 1, and provide the drive with both an enable signal (on terminal 31) and a run signal (on terminal 26 or 27).</li> <li>• A rotating autotune should only be used if the motor is unloaded. A rotating autotune first performs a stationary autotune, as above, before rotating the motor at <math>\frac{2}{3}</math> base speed in the direction selected for several seconds (regardless of the speed reference). In addition to the stator resistance (Pr <b>5.17</b>) and voltage offset (Pr <b>5.23</b>), the rotating autotune measures the power factor of the motor and updates Pr <b>0.43</b> with the correct value. To perform a Rotating autotune, set Pr <b>0.40</b> to 2, and provide the drive with both an enable signal (on terminal 31) and a run signal (on terminal 26 or 27).</li> </ul> <p>Following the completion of an autotune test the drive will go into the inhibit state. The drive must be placed into a controlled disable condition before the drive can be made to run at the required reference. The drive can be put in to a controlled disable condition by removing the Secure Disable signal from terminal 31, setting the drive enable parameter Pr <b>6.15</b> to OFF (0) or disabling the drive via the control word (Pr <b>6.42</b> &amp; Pr <b>6.43</b>).</p> |  |

## Pr 0.07 {5.14} Voltage mode

There are six voltage modes available which fall into two categories, vector control and fixed boost.

### Vector control

Vector control mode provides the motor with a linear voltage characteristic from 0Hz to motor rated frequency (Pr 0.47), and then a constant voltage above motor rated frequency. When the drive operates between motor rated frequency/50 and motor rated frequency/4, full vector based stator resistance compensation is applied. When the drive operates between motor rated frequency/4 and motor rated frequency/2 the stator resistance compensation is gradually reduced to zero as the frequency increases. For the vector modes to operate correctly the motor rated power factor (Pr 0.43), stator resistance (Pr 5.17) and voltage offset (Pr 5.23) are all required to be set up accurately. The drive can be made to measure these by performing an autotune (see Pr 0.40 Autotune). The drive can also be made to measure the stator resistance and voltage offset automatically every time the drive is enabled or the first time the drive is enabled after it is powered up, by selecting one of the vector control voltage modes.

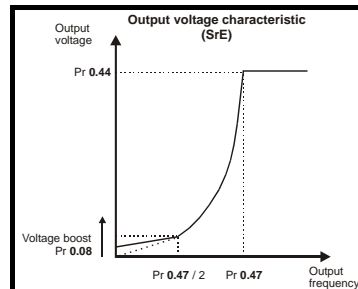
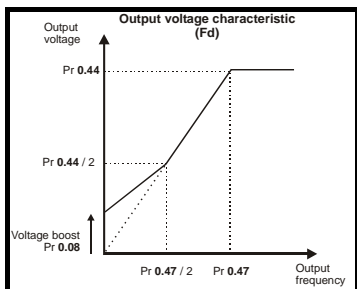
- (0) **Ur\_S** = The stator resistance and the voltage offset are measured and the parameters for the selected motor map are over-written each time the drive is made to run. This test can only be done with a stationary motor where the flux has decayed to zero. Therefore this mode should only be used if the motor is guaranteed to be stationary each time the drive is made to run. To prevent the test from being done before the flux has decayed there is a period of 1 second after the drive has been in the ready state during which the test is not done if the drive is made to run again. In this case, previously measured values are used. Ur\_s mode ensures that the drive compensates for any change in motor parameters due to changes in temperature. The new values of stator resistance and voltage offset are not automatically saved to the drive's EEPROM.
- (4) **Ur\_I** = The stator resistance and voltage offset are measured when the drive is first made to run after each power-up. This test can only be done with a stationary motor. Therefore this mode should only be used if the motor is guaranteed to be stationary the first time the drive is made to run after each power-up. The new values of stator resistance and voltage offset are not automatically saved to the drive's EEPROM.
- (1) **Ur** = The stator resistance and voltage offset are not measured. The user can enter the motor and cabling resistance into the stator resistance parameter (Pr 5.17). However this will not include resistance effects within the drive inverter. Therefore if this mode is to be used, it is best to use an autotune test initially to measure the stator resistance and voltage offset.
- (3) **Ur\_Auto** = The stator resistance and voltage offset are measured once, the first time the drive is made to run. After the test has been completed successfully the voltage mode (Pr 0.07) is changed to Ur mode. The stator resistance (Pr 5.17) and voltage offset (Pr 5.23) parameters are written to, and along with the voltage mode (Pr 0.07), are saved in the drive's EEPROM. If the test fails, the voltage mode will stay set to Ur\_Auto and the test will be repeated next time the drive is made to run.

### Fixed boost

Neither the stator resistance nor the voltage offset are used in the control of the motor, instead a fixed characteristic with low frequency voltage boost as defined by parameter Pr 0.08, is used. Fixed boost mode should be used when the drive is controlling multiple motors. There are two settings of fixed boost available:

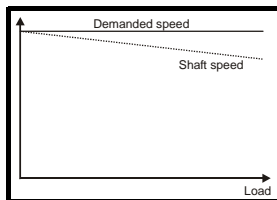
- (2) **Fd** = This mode provides the motor with a linear voltage characteristic from 0Hz to rated frequency (Pr 0.47), and then a constant voltage above rated frequency.
- (5) **SrE** = This mode provides the motor with a square law voltage characteristic from 0Hz to rated frequency (Pr 0.47), and then a constant voltage above rated frequency. This mode is suitable for variable torque applications like fans and pumps where the load is proportional to the square of the speed of the motor shaft. This mode should not be used if a high starting torque is required.

For both these modes, at low frequencies (from 0Hz to  $\frac{1}{2} \times$  Pr 0.47) a voltage boost is applied defined by Pr 0.08 as shown below:



## Pr 5.27 Slip compensation

When a motor, being controlled in open loop mode, has load applied a characteristic of the motor is that the output speed droops in proportion to the load applied as shown:



In order to prevent the speed droop shown above slip compensation should be enabled.

To enable slip compensation Pr 5.27 must be set to a 1 (this is the default setting), and the motor rated speed must be entered in Pr 0.45 (Pr 5.08). The motor rated speed parameter should be set to the synchronous speed of the motor minus the slip speed. This is normally displayed on the motor nameplate, i.e. for a typical 18.5kW, 50Hz, 4 pole motor, the motor rated speed would be approximately 1465rpm. The synchronous speed for a 50Hz, 4 pole motor is 1500rpm, so therefore the slip speed would be 35rpm.

If the synchronous speed is entered in Pr 0.45, slip compensation will be disabled. If too small a value is entered in Pr 0.45, the motor will run faster than the demanded frequency.

The synchronous speeds for 50Hz motors with different numbers of poles are as follows:

2 pole = 3000rpm, 4 pole = 1500rpm, 6pole = 1000rpm, 8 pole = 750rpm

## 8.1.2 RFC mode

|   |  |
|---|--|
| <b>Pr 0.46 {5.07} Motor rated current</b>   | <b>Defines the maximum motor continuous current</b>                |
| <p>The motor rated current parameter must be set to the maximum continuous current of the motor. (See section 8.2 <i>Maximum motor rated current</i> on page 148, for information about setting this parameter higher than the maximum Heavy Duty current rating.) The motor rated current is used in the following:</p> <ul style="list-style-type: none"> <li>• Current limits (see section 8.3 <i>Current limits</i> on page 148, for more information)</li> <li>• Motor thermal overload protection (see section 8.4 <i>Motor thermal protection</i> on page 148, for more information)</li> <li>• Vector control algorithm</li> </ul>  |  |
| <b>Pr 0.44 {5.09} Motor rated voltage</b>   | <b>Defines the voltage applied to the motor at rated frequency</b> |
| <b>Pr 0.47 {5.06} Motor rated frequency</b>   | <b>Defines the frequency at which rated voltage is applied</b>     |
| <p>The motor rated voltage Pr <b>0.44</b> and the motor rated frequency Pr <b>0.47</b> are used to define the relationship between the voltage and frequency applied to the motor, as shown.</p> <p>The motor rated voltage is used by the field controller to limit the voltage applied to the motor. Normally this is set to the nameplate value. To allow current control to be maintained, it is necessary for the drive to leave some 'headroom' between the motor terminal voltage and the maximum available drive output voltage. For good transient performance at high speed, the motor rated voltage should be set below 95% of the minimum supply voltage to the drive.</p> <p>The motor rated voltage and motor rated frequency are also used during the rotating autotune test (see Autotune Pr <b>0.40</b> later in this table) and in the calculations required for automatic optimisation of the motor rated speed (see Motor rated speed optimisation Pr <b>5.16</b>, later in this table). Therefore, it is important that the correct value for motor rated voltage is used.</p>   |  |
| <p>The graph, titled 'Output voltage characteristic', plots Output voltage on the vertical axis against Output frequency on the horizontal axis. A solid line starts at the origin and rises linearly. At a frequency of Pr 0.47, the line reaches a voltage of Pr 0.44 and then continues as a horizontal line. A dashed line from the point (Pr 0.47 / 2, Pr 0.44 / 2) meets the linear portion of the graph. Another dashed line from Pr 0.47 on the frequency axis meets the horizontal portion of the graph.</p>   |  |
| <b>Pr 0.45 {5.08} Motor rated speed</b>   | <b>Defines the full load rated speed of the motor</b>              |
| <b>Pr 0.42 {5.11} Motor number of poles</b>   | <b>Defines the number of motor poles</b>                           |
| <p>The motor rated speed and motor rated frequency are used to determine the full load slip of the motor which is used by the vector control algorithm. Incorrect setting of this parameter has the following effects:</p> <ul style="list-style-type: none"> <li>• Reduced efficiency of motor operation</li> <li>• Reduction of maximum torque available from the motor</li> <li>• Reduced transient performance</li> <li>• Inaccurate control of absolute torque in torque control modes</li> </ul> <p>The nameplate value is normally the value for a hot motor; however, some adjustment may be required when the drive is commissioned if the nameplate value is inaccurate. Either a fixed value can be entered in this parameter or an optimisation system may be used to automatically adjust this parameter (see Motor rated speed autotune Pr <b>5.16</b>, later in this table).</p> <p>When Pr <b>0.42</b> is set to 'Auto', the number of motor poles is automatically calculated from the motor rated frequency Pr <b>0.47</b>, and the motor rated speed Pr <b>0.45</b></p> $\text{Number of poles} = 120 \times (\text{Motor rated frequency Pr } 0.47 / \text{Motor rated speed Pr } 0.45) \text{ rounded to the nearest even number}$ |  |
| <b>Pr 0.43 {5.10} Motor rated power factor</b>  | <b>Defines the angle between the motor voltage and current</b>     |
| <p>The power factor is the true power factor of the motor, i.e. the angle between the motor voltage and current. If the stator inductance is set to zero (Pr <b>5.25</b>) then the power factor is used in conjunction with the motor rated current Pr <b>0.46</b> and other motor parameters to calculate the rated active and magnetising currents of the motor, which are used in the vector control algorithm. If the stator inductance has a non-zero value this parameter is not used by the drive, but is continuously written with a calculated value of power factor. The stator inductance can be measured by the drive by performing a rotating autotune (see Autotune Pr <b>0.40</b>, later in this table).</p>   |  |

### Pr 0.40 {5.12} Autotune

There are three autotune tests available in RFC mode, a stationary test, a rotating test and an inertia measurement test. A stationary autotune will give moderate performance whereas a rotating autotune will give improved performance as it measures the actual values of the motor parameters required by the drive. An inertia measurement test should be performed separately to a stationary or rotating autotune.

- A stationary autotune can be used when the motor is loaded and it is not possible to remove the load from the motor shaft. The stationary autotune measures the stator resistance (Pr 5.17) and transient inductance (Pr 5.24) of the motor. These are used to calculate the current loop gains, and at the end of the test the values in Pr 4.13 and Pr 4.14 are updated. A stationary autotune does not measure the power factor of the motor so the value on the motor nameplate must be entered into Pr 0.43. To perform a Stationary autotune, set Pr 0.40 to 1, and provide the drive with both an enable signal (on terminal 31) and a run signal (on terminal 26 or 27).
- A rotating autotune should only be used if the motor is unloaded. A rotating autotune first performs a stationary autotune before rotating the motor at  $\frac{2}{3}$  of motor rated frequency in the direction selected for approximately 30s. During the rotating autotune the stator inductance (Pr 5.25), and the motor saturation breakpoints (Pr 5.29 and Pr 5.30) are modified by the drive. The power factor is also modified for user information only, but is not used after this point as the stator inductance is used in the vector control algorithm instead. To perform a Rotating autotune, set Pr 0.40 to 2, and provide the drive with both an enable signal (on terminal 31) and a run signal (on terminal 26 or 27).
- The inertia measurement test can measure the total inertia of the load and the motor. This is used to set the speed loop gains (see *Speed loop gains*) and to provide torque feed-forwards when required during acceleration.

During the inertia measurement test the drive attempts to accelerate the motor in the direction selected up to  $\frac{3}{4}$  x rated load rpm and then back to standstill. The drive uses rated torque/16, but if the motor cannot be accelerated to the required speed the drive then increases the torque progressively to  $x\frac{1}{8}$ ,  $x\frac{1}{4}$ ,  $x\frac{1}{2}$  and  $x1$  rated torque. If the required speed is not achieved on the final attempt the test is aborted and a tunE1 trip is initiated. If the test is successful the acceleration and deceleration times are used to calculate the motor and load inertia which is then written to Pr 3.18. The motor map parameters must be set up correctly including the power factor before performing an inertia measurement test.

To perform an Inertia measurement autotune, set Pr 0.40 to 3, and provide the drive with both an enable signal (on terminal 31) and a run signal (on terminal 26 or 27).

Following the completion of an autotune test the drive will go into the inhibit state. The drive must be placed into a controlled disable condition before the drive can be made to run at the required reference. The drive can be put in to a controlled disable condition by removing the Secure Disable signal from terminal 31, setting the drive enable parameter Pr 6.15 to OFF (0) or disabling the drive via the control word (Pr 6.42 & Pr 6.43).

### Pr 5.16 Motor rated speed autotune

The motor rated speed parameter (Pr 0.45) in conjunction with the motor rated frequency parameter (Pr 0.47) defines the full load slip of the motor. The slip is used in the motor model for RFC control. The full load slip of the motor varies with rotor resistance which can vary significantly with motor temperature. When Pr 5.16 is set to 1 or 2 the drive can automatically sense if the value of slip defined by Pr 0.47 and Pr 0.45 has been set incorrectly or if it has varied with motor temperature. If the value is incorrect Pr 0.45 is automatically adjusted. Pr 0.45 is not saved at power-down, and so when the drive is powered-down and up again it will return to the last saved value. If the new value is required at the next power-up it must be saved by the user. Automatic optimisation is only enabled when the speed is above rated speed/8, and when the load on the motor load rises above  $\frac{5}{8}$  rated load. Optimisation is disabled again if the load falls below  $\frac{1}{2}$  rated load. For best optimisation results the correct values of stator resistance (Pr 5.17), transient inductance (Pr 5.24), stator inductance (Pr 5.25) and saturation breakpoints (Pr 5.29, Pr 5.30) should be stored in the relevant parameters (all these can be measured by the drive by performing a rotating autotune). Motor rated speed autotune is not available if the drive is not using external position/speed feedback.

The gain of the optimiser, and hence the speed with which it converges, can be set at a normal low level when Pr 5.16 is set to 1. If this parameter is set to 2, the gain is increased by a factor of 16 to give faster convergence.

### Pr 0.38 {4.13} / Pr 0.39 {4.14} Current loop gains

The current loop gains proportional (Kp) and integral (Ki) gains control the response of the current loop to a change in current (torque) demand. The default values give satisfactory operation with most motors. However, for optimal performance in dynamic applications it may be necessary to change the gains to improve the performance. The proportional gain (Pr 4.13) is the most critical value in controlling the performance. The values for the current loop gains can be calculated by one of the following:

- During a stationary or rotating autotune (see *Autotune Pr 0.40*, earlier in this table) the drive measures the stator resistance (Pr 5.17) and transient inductance (Pr 5.24) of the motor and calculates the current loop gains.
- By setting Pr 0.40 to 4 the drive will calculate the current loop gains from the values of stator resistance (Pr 5.17) and transient inductance (Pr 5.24) set in the drive.

This will give a step response with minimum overshoot after a step change of current reference. The proportional gain can be increased by a factor of 1.5 giving a similar increase in bandwidth; however, this gives a step response with approximately 12.5% overshoot. The equation for the integral gain gives a conservative value. In some applications where it is necessary for the reference frame used by the drive to dynamically follow the flux very closely (i.e. high speed RFC induction motor applications) the integral gain may need to have a significantly higher value.

## Speed loop gains (Pr 0.07 {3.10}, Pr 0.08 {3.11}, Pr 0.09 {3.12})

The speed loop gains control the response of the speed controller to a change in speed demand. The speed controller includes proportional ( $K_p$ ) and integral ( $K_i$ ) feed forward terms, and a differential ( $K_d$ ) feedback term. The drive holds two sets of these gains and either set may be selected for use by the speed controller with Pr 3.16. If Pr 3.16 = 0, gains  $K_{p1}$ ,  $K_{i1}$  and  $K_{d1}$  (Pr 0.07 to Pr 0.09) are used, and if Pr 3.16 = 1, gains  $K_{p2}$ ,  $K_{i2}$  and  $K_{d2}$  (Pr 3.13 to Pr 3.15) are used. Pr 3.16 may be changed when the drive is enabled or disabled. If the load is predominantly a constant inertia and constant torque, the drive can calculate the required  $K_p$  and  $K_i$  gains to give a required compliance angle or bandwidth dependant on the setting of Pr 3.17.

### Proportional gain ( $K_p$ ), Pr 0.07 {3.10} and Pr 3.13

If the proportional gain has a value and the integral gain is set to zero the controller will only have a proportional term, and there must be a speed error to produce a torque reference. Therefore as the motor load increases there will be a difference between the reference and actual speeds. This effect, called regulation, depends on the level of the proportional gain, the higher the gain the smaller the speed error for a given load. If the proportional gain is too high either the acoustic noise produced by speed feedback quantisation becomes unacceptable, or the stability limit is reached.

### Integral gain ( $K_i$ ), Pr 0.08 {3.11} and Pr 3.14

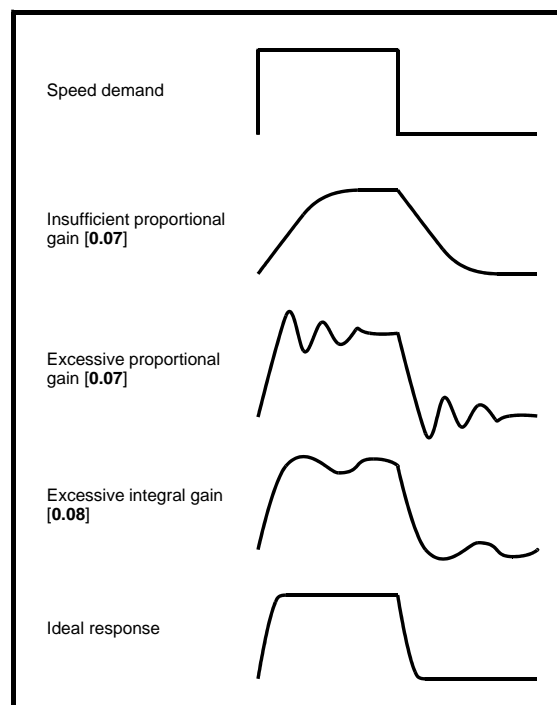
The integral gain is provided to prevent speed regulation. The error is accumulated over a period of time and used to produce the necessary torque demand without any speed error. Increasing the integral gain reduces the time taken for the speed to reach the correct level and increases the stiffness of the system, i.e. it reduces the positional displacement produced by applying a load torque to the motor. Unfortunately increasing the integral gain also reduces the system damping giving overshoot after a transient. For a given integral gain the damping can be improved by increasing the proportional gain. A compromise must be reached where the system response, stiffness and damping are all adequate for the application.

### Differential gain ( $K_d$ ), Pr 0.09 {3.12} and Pr 3.15

The differential gain is provided in the feedback of the speed controller to give additional damping. The differential term is implemented in a way that does not introduce excessive noise normally associated with this type of function. Increasing the differential term reduces the overshoot produced by under-damping, however, for most applications the proportional and integral gains alone are sufficient.

There are three methods of tuning the speed loop gains dependant on the setting of Pr 3.17:

1. Pr 3.17 = 0, User set-up.  
This involves the connecting of an oscilloscope to analogue output 1 to monitor the speed feedback.  
Give the drive a step change in speed reference and monitor the response of the drive on the oscilloscope.  
The proportional gain ( $K_p$ ) should be set up initially. The value should be increased up to the point where the speed overshoots and then reduced slightly.  
The integral gain ( $K_i$ ) should then be increased up to the point where the speed becomes unstable and then reduced slightly.  
It may now be possible to increase the proportional gain to a higher value and the process should be repeated until the system response matches the ideal response as shown.  
The diagram shows the effect of incorrect P and I gain settings as well as the ideal response.
2. Pr 3.17 = 1, Bandwidth set-up  
If bandwidth based set-up is required, the drive can calculate  $K_p$  and  $K_i$  if the following parameters are set up correctly:  
Pr 3.20 - Required bandwidth,  
Pr 3.21 - Required damping factor,  
Pr 3.18 - Motor and load inertia. The drive can be made to measure the motor and load inertia by performing an inertia measurement autotune (see Autotune Pr 0.40, earlier in this table).
3. Pr 3.17 = 2, Compliance angle set-up  
If compliance angle based set-up is required, the drive can calculate  $K_p$  and  $K_i$  if the following parameters are set up correctly:  
Pr 3.19 - Required compliance angle,  
Pr 3.21 - Required damping factor,  
Pr 3.18 - Motor and load inertia. The drive can be made to measure the motor and load inertia by performing an inertia measurement autotune (see Autotune Pr 0.40, earlier in this table).



### 8.1.3 Closed loop vector motor control

#### Pr 0.46 {5.07} Motor rated current

Defines the maximum motor continuous current

The motor rated current parameter must be set to the maximum continuous current of the motor. (See section 8.2 *Maximum motor rated current* on page 148, for information about setting this parameter higher than the maximum Heavy Duty current rating.) The motor rated current is used in the following:

- Current limits (see section 8.3 *Current limits* on page 148, for more information)
- Motor thermal overload protection (see section 8.4 *Motor thermal protection* on page 148, for more information)
- Vector control algorithm

#### Pr 0.44 {5.09} Motor rated voltage

Defines the voltage applied to the motor at rated frequency

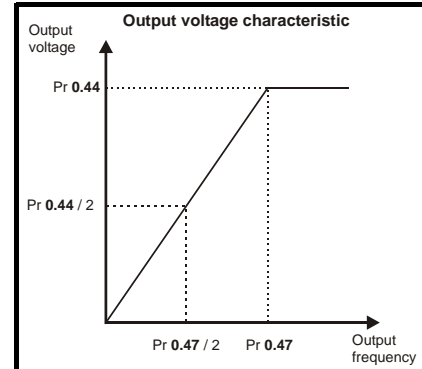
#### Pr 0.47 {5.06} Motor rated frequency

Defines the frequency at which rated voltage is applied

The motor rated voltage Pr 0.44 and the motor rated frequency Pr 0.47 are used to define the relationship between the voltage and frequency applied to the motor, as shown.

The motor rated voltage is used by the field controller to limit the voltage applied to the motor. Normally this is set to the nameplate value. To allow current control to be maintained, it is necessary for the drive to leave some 'headroom' between the motor terminal voltage and the maximum available drive output voltage. For good transient performance at high speed, the motor rated voltage should be set below 95% of the minimum supply voltage to the drive.

The motor rated voltage and motor rated frequency are also used during the rotating autotune test (see Autotune Pr 0.40 later in this table) and in the calculations required for automatic optimisation of the motor rated speed (see Motor rated speed optimisation Pr 5.16, later in this table). Therefore, it is important that the correct value for motor rated voltage is used.



#### Pr 0.45 {5.08} Motor rated speed

Defines the full load rated speed of the motor

#### Pr 0.42 {5.11} Motor number of poles

Defines the number of motor poles

The motor rated speed and motor rated frequency are used to determine the full load slip of the motor which is used by the vector control algorithm. Incorrect setting of this parameter has the following effects:

- Reduced efficiency of motor operation
- Reduction of maximum torque available from the motor
- Reduced transient performance
- Inaccurate control of absolute torque in torque control modes

The nameplate value is normally the value for a hot motor; however, some adjustment may be required when the drive is commissioned if the nameplate value is inaccurate. Either a fixed value can be entered in this parameter or an optimisation system may be used to automatically adjust this parameter (see Motor rated speed autotune Pr 5.16, later in this table).

When Pr 0.42 is set to 'Auto', the number of motor poles is automatically calculated from the motor rated frequency Pr 0.47, and the motor rated speed Pr 0.45

$$\text{Number of poles} = 120 \times (\text{Motor rated frequency Pr 0.47} / \text{Motor rated speed Pr 0.45}) \text{ rounded to the nearest even number}$$

#### Pr 0.43 {5.10} Motor rated power factor

Defines the angle between the motor voltage and current

The power factor is the true power factor of the motor, i.e. the angle between the motor voltage and current. If the stator inductance is set to zero (Pr 5.25) then the power factor is used in conjunction with the motor rated current Pr 0.46 and other motor parameters to calculate the rated active and magnetising currents of the motor, which are used in the vector control algorithm. If the stator inductance has a non-zero value this parameter is not used by the drive, but is continuously written with a calculated value of power factor. The stator inductance can be measured by the drive by performing a rotating autotune (see Autotune Pr 0.40, later in this table).

### Pr 0.40 {5.12} Autotune

There are three autotune tests available in closed loop vector mode, a stationary test, a rotating test and an inertia measurement test. A stationary autotune will give moderate performance whereas a rotating autotune will give improved performance as it measures the actual values of the motor parameters required by the drive. An inertia measurement test should be performed separately to a stationary or rotating autotune.

- A stationary autotune can be used when the motor is loaded and it is not possible to remove the load from the motor shaft. The stationary autotune measures the stator resistance (Pr 5.17) and transient inductance (Pr 5.24) of the motor. These are used to calculate the current loop gains, and at the end of the test the values in Pr 4.13 and Pr 4.14 are updated. A stationary autotune does not measure the power factor of the motor so the value on the motor nameplate must be entered into Pr 0.43. To perform a Stationary autotune, set Pr 0.40 to 1, and provide the drive with both an enable signal (on terminal 31) and a run signal (on terminal 26 or 27).
- A rotating autotune should only be used if the motor is unloaded. A rotating autotune first performs a stationary autotune before rotating the motor at  $\frac{2}{3}$  of motor rated frequency in the direction selected for approximately 30s. During the rotating autotune the stator inductance (Pr 5.25), and the motor saturation breakpoints (Pr 5.29 and Pr 5.30) are modified by the drive. The power factor is also modified for user information only, but is not used after this point as the stator inductance is used in the vector control algorithm instead. To perform a Rotating autotune, set Pr 0.40 to 2, and provide the drive with both an enable signal (on terminal 31) and a run signal (on terminal 26 or 27).
- The inertia measurement test can measure the total inertia of the load and the motor. This is used to set the speed loop gains (see *Speed loop gains*) and to provide torque feed-forwards when required during acceleration.

During the inertia measurement test the drive attempts to accelerate the motor in the direction selected up to  $\frac{3}{4}$  x rated load rpm and then back to standstill. The drive uses rated torque/16, but if the motor cannot be accelerated to the required speed the drive then increases the torque progressively to  $x\frac{1}{8}$ ,  $x\frac{1}{4}$ ,  $x\frac{1}{2}$  and  $x1$  rated torque. If the required speed is not achieved on the final attempt the test is aborted and a tunE1 trip is initiated. If the test is successful the acceleration and deceleration times are used to calculate the motor and load inertia which is then written to Pr 3.18. The motor map parameters must be set up correctly including the power factor before performing an inertia measurement test.

To perform an Inertia measurement autotune, set Pr 0.40 to 3, and provide the drive with both an enable signal (on terminal 31) and a run signal (on terminal 26 or 27).

Following the completion of an autotune test the drive will go into the inhibit state. The drive must be placed into a controlled disable condition before the drive can be made to run at the required reference. The drive can be put in to a controlled disable condition by removing the Secure Disable signal from terminal 31, setting the drive enable parameter Pr 6.15 to OFF (0) or disabling the drive via the control word (Pr 6.42 & Pr 6.43).

### Pr 5.16 Motor rated speed autotune

The motor rated speed parameter (Pr 0.45) in conjunction with the motor rated frequency parameter (Pr 0.47) defines the full load slip of the motor. The slip is used in the motor model for closed-loop vector control. The full load slip of the motor varies with rotor resistance which can vary significantly with motor temperature. When Pr 5.16 is set to 1 or 2 the drive can automatically sense if the value of slip defined by Pr 0.47 and Pr 0.45 has been set incorrectly or if it has varied with motor temperature. If the value is incorrect Pr 0.45 is automatically adjusted. Pr 0.45 is not saved at power-down, and so when the drive is powered-down and up again it will return to the last saved value. If the new value is required at the next power-up it must be saved by the user. Automatic optimisation is only enabled when the speed is above rated speed/8, and when the load on the motor load rises above  $\frac{5}{8}$  rated load. Optimisation is disabled again if the load falls below  $\frac{1}{2}$  rated load. For best optimisation results the correct values of stator resistance (Pr 5.17), transient inductance (Pr 5.24), stator inductance (Pr 5.25) and saturation breakpoints (Pr 5.29, Pr 5.30) should be stored in the relevant parameters (all these can be measured by the drive by performing a rotating autotune). Motor rated speed autotune is not available if the drive is not using external position/speed feedback.

The gain of the optimiser, and hence the speed with which it converges, can be set at a normal low level when Pr 5.16 is set to 1. If this parameter is set to 2, the gain is increased by a factor of 16 to give faster convergence.

### Pr 0.38 {4.13} / Pr 0.39 {4.14} Current loop gains

The current loop gains proportional (Kp) and integral (Ki) gains control the response of the current loop to a change in current (torque) demand. The default values give satisfactory operation with most motors. However, for optimal performance in dynamic applications it may be necessary to change the gains to improve the performance. The proportional gain (Pr 4.13) is the most critical value in controlling the performance. The values for the current loop gains can be calculated by one of the following:

- During a stationary or rotating autotune (see *Autotune Pr 0.40*, earlier in this table) the drive measures the stator resistance (Pr 5.17) and transient inductance (Pr 5.24) of the motor and calculates the current loop gains.
- By setting Pr 0.40 to 4 the drive will calculate the current loop gains from the values of stator resistance (Pr 5.17) and transient inductance (Pr 5.24) set in the drive.

This will give a step response with minimum overshoot after a step change of current reference. The proportional gain can be increased by a factor of 1.5 giving a similar increase in bandwidth; however, this gives a step response with approximately 12.5% overshoot. The equation for the integral gain gives a conservative value. In some applications where it is necessary for the reference frame used by the drive to dynamically follow the flux very closely (i.e. high speed closed-loop induction motor applications) the integral gain may need to have a significantly higher value.

## Speed loop gains (Pr 0.07 {3.10}, Pr 0.08 {3.11}, Pr 0.09 {3.12})

The speed loop gains control the response of the speed controller to a change in speed demand. The speed controller includes proportional (Kp) and integral (Ki) feed forward terms, and a differential (Kd) feedback term. The drive holds two sets of these gains and either set may be selected for use by the speed controller with Pr 3.16. If Pr 3.16 = 0, gains Kp1, Ki1 and Kd1 (Pr 0.07 to Pr 0.09) are used, and if Pr 3.16 = 1, gains Kp2, Ki2 and Kd2 (Pr 3.13 to Pr 3.15) are used. Pr 3.16 may be changed when the drive is enabled or disabled. If the load is predominantly a constant inertia and constant torque, the drive can calculate the required Kp and Ki gains to give a required compliance angle or bandwidth dependant on the setting of Pr 3.17.

### Proportional gain (Kp), Pr 0.07 {3.10} and Pr 3.13

If the proportional gain has a value and the integral gain is set to zero the controller will only have a proportional term, and there must be a speed error to produce a torque reference. Therefore as the motor load increases there will be a difference between the reference and actual speeds. This effect, called regulation, depends on the level of the proportional gain, the higher the gain the smaller the speed error for a given load. If the proportional gain is too high either the acoustic noise produced by speed feedback quantisation becomes unacceptable, or the closed-loop stability limit is reached.

### Integral gain (Ki), Pr 0.08 {3.11} and Pr 3.14

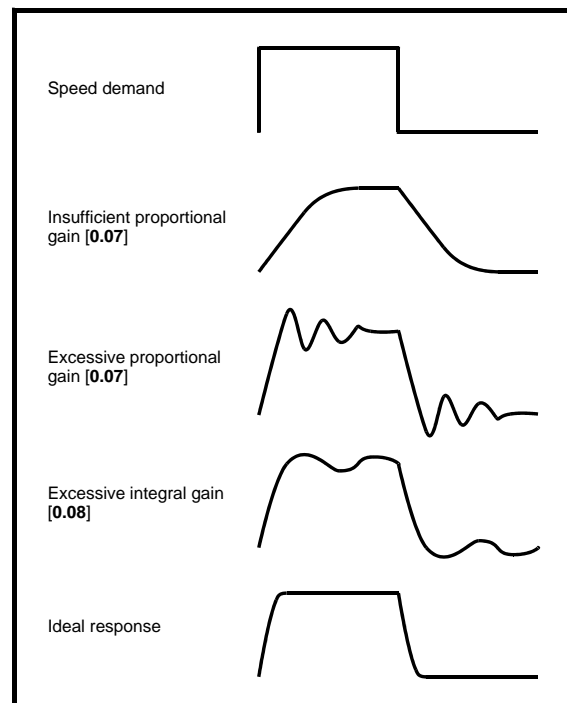
The integral gain is provided to prevent speed regulation. The error is accumulated over a period of time and used to produce the necessary torque demand without any speed error. Increasing the integral gain reduces the time taken for the speed to reach the correct level and increases the stiffness of the system, i.e. it reduces the positional displacement produced by applying a load torque to the motor. Unfortunately increasing the integral gain also reduces the system damping giving overshoot after a transient. For a given integral gain the damping can be improved by increasing the proportional gain. A compromise must be reached where the system response, stiffness and damping are all adequate for the application.

### Differential gain (Kd), Pr 0.09 {3.12} and Pr 3.15

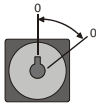
The differential gain is provided in the feedback of the speed controller to give additional damping. The differential term is implemented in a way that does not introduce excessive noise normally associated with this type of function. Increasing the differential term reduces the overshoot produced by under-damping, however, for most applications the proportional and integral gains alone are sufficient.

There are three methods of tuning the speed loop gains dependant on the setting of Pr 3.17:

- Pr 3.17 = 0, User set-up.  
This involves the connecting of an oscilloscope to analogue output 1 to monitor the speed feedback.  
Give the drive a step change in speed reference and monitor the response of the drive on the oscilloscope.  
The proportional gain (Kp) should be set up initially. The value should be increased up to the point where the speed overshoots and then reduced slightly.  
The integral gain (Ki) should then be increased up to the point where the speed becomes unstable and then reduced slightly.  
It may now be possible to increase the proportional gain to a higher value and the process should be repeated until the system response matches the ideal response as shown.  
The diagram shows the effect of incorrect P and I gain settings as well as the ideal response.
- Pr 3.17 = 1, Bandwidth set-up  
If bandwidth based set-up is required, the drive can calculate Kp and Ki if the following parameters are set up correctly:  
Pr 3.20 - Required bandwidth,  
Pr 3.21 - Required damping factor,  
Pr 3.18 - Motor and load inertia. The drive can be made to measure the motor and load inertia by performing an inertia measurement autotune (see Autotune Pr 0.40, earlier in this table).
- Pr 3.17 = 2, Compliance angle set-up  
If compliance angle based set-up is required, the drive can calculate Kp and Ki if the following parameters are set up correctly:  
Pr 3.19 - Required compliance angle,  
Pr 3.21 - Required damping factor,  
Pr 3.18 - Motor and load inertia. The drive can be made to measure the motor and load inertia by performing an inertia measurement autotune (see Autotune Pr 0.40, earlier in this table).



## 8.1.4 Servo motor control

|  |   |
|--|---|
| <b>Pr 0.46 {5.07} Motor rated current</b>  | <b>Defines the maximum motor continuous current</b> |
| <p>The motor rated current parameter must be set to the maximum continuous current of the motor. The motor rated current is used in the following:</p> <ul style="list-style-type: none"> <li>• Current limits (see section 8.3 <i>Current limits</i> on page 148, for more information)</li> <li>• Motor thermal overload protection (see section 8.4 <i>Motor thermal protection</i> on page 148, for more information)</li> </ul>   |   |
| <b>Pr 0.42 {5.11} Motor number of poles</b>  | <b>Defines the number of motor poles</b>            |
| <p>The motor number of poles parameter defines the number of electrical revolutions in one whole mechanical revolution of the motor. This parameter must be set correctly for the control algorithms to operate correctly. When Pr <b>0.42</b> is set to "Auto" the number of poles is 6.</p>  |   |
| <b>Pr 0.40 {5.12} Autotune</b>   |   |
| <p>There are five autotune tests available in servo mode, a short low speed test, a normal low speed test, an inertia measurement test, a stationary test to set up current controller gains and a minimal movement phasing test. A normal low speed should be done where possible as the drive measures the stator resistance and inductance of the motor, and from these calculates the current loop gains. An inertia measurement test should be performed separately to a short low speed or normal low speed autotune.</p> <ul style="list-style-type: none"> <li>• A short low speed test will rotate the motor by 2 electrical revolutions (i.e. up to 2 mechanical revolutions) in the direction selected. The drive applies rated current to the motor during the test and measures the encoder phase angle (Pr <b>3.25</b>). The phase angle measurement is taken when the motor has stopped at the end of the test, therefore there must be no load on the motor when it is at rest for the correct angle to be measured. This test takes approximately 2 seconds to complete and can only be used where the rotor settles to a stable position in a short time. To perform a short low speed autotune, set Pr <b>0.40</b> to 1, and provide the drive with both an enable signal (on terminal 31) and a run signal (on terminal 26 or 27).</li> <li>• A normal low speed test will rotate the motor by 2 electrical revolutions (i.e. up to 2 mechanical revolutions) in the direction selected. The drive applies rated current to the motor during the test and measures the encoder phase angle (Pr <b>3.25</b>). The phase angle measurement is taken when the motor has stopped at the end of the test, therefore there must be no load on the motor when it is at rest for the correct angle to be measured. The motor resistance (Pr <b>5.17</b>) and inductance (Pr <b>5.24</b>) are then measured, and the values are used to set up the current loop gains (Pr <b>0.38 {4.13}</b> and Pr <b>0.39 {4.14}</b>). The whole test takes approximately 20 seconds and can be used with motors that take time to settle after the rotor has moved. During the motor inductance measurement the drive applies current pulses to the motor that produces flux that opposes the flux produced by the magnets. The maximum current applied is a quarter of rated current (Pr <b>0.46</b>). This current is unlikely to affect the motor magnets, however, if this level of current could permanently de-magnetise the magnets the rated current should be set to a lower level for the tests to avoid this. To perform a normal low speed autotune, set Pr <b>0.40</b> to 2, and provide the drive with both an enable signal (on terminal 31) and a run signal (on terminal 26 or 27).</li> </ul> <div style="text-align: center;">  </div> <ul style="list-style-type: none"> <li>• The inertia measurement test can measure the total inertia of the load and the motor. This is used to set the speed loop gains (see <i>Speed loop gains</i>) and to provide torque feed-forwards when required during acceleration. During the inertia measurement test the drive attempts to accelerate the motor in the direction selected up to <math>\frac{3}{4}</math> x rated load rpm and then back to standstill. The drive uses rated torque/16, but if the motor cannot be accelerated to the required speed the drive then increases the torque progressively to <math>\frac{1}{8}</math>, <math>\frac{1}{4}</math>, <math>\frac{1}{2}</math> and x1 rated torque. If the required speed is not achieved on the final attempt the test is aborted and a tunE1 trip is initiated. If the test is successful the acceleration and deceleration times are used to calculate the motor and load inertia which is then written to Pr <b>3.18</b>. The value of the value of motor torque per amp in Pr <b>5.32</b> and the motor rated speed in Pr <b>5.08</b> must be set up correctly before performing an inertia measurement test. To perform an Inertia measurement autotune, set Pr <b>0.40</b> to 3, and provide the drive with both an enable signal (on terminal 31) and a run signal (on terminal 26 or 27).</li> <li>• The stationary test to set up current controller gains measures the stator resistance and the transient inductance of the motor, calculates the current loop gains and updates the current loop gain parameters. This test does not measure the encoder phase angle. This test should only be performed when the correct phasing angle has been set in Pr <b>0.43</b>. If the phasing angle is not correct the motor may move and the results may be incorrect. To perform a stationary test to set up current controller gains, set Pr <b>0.40</b> to 4, and provide the drive with both an enable signal (on terminal 31) and a run signal (on terminal 26 or 27).</li> <li>• A minimal movement phasing test can measure the encoder phase offset by moving the motor through a small angle. Short current pulses are applied to the motor to produce a small movement and then to move the motor back to the original position. The size and length of the pulses are gradually increased (up to a maximum of motor rated current) until the movement is approximately at the level defined by Pr <b>5.38</b> electrical degrees. The resulting movements are used to estimate the phase angle. To perform a minimal movement phasing test, set Pr <b>0.40</b> to 5, and provide the drive with both an enable signal (on terminal 31) and a run signal (on terminal 26 or 27).</li> </ul> <p>Following the completion of an autotune test the drive will go into the inhibit state. The drive must be placed into a controlled disable condition before the drive can be made to run at the required reference. The drive can be put in to a controlled disable condition by removing the Secure Disable signal from terminal 31, setting the drive enable parameter Pr <b>6.15</b> to OFF (0) or disabling the drive via the control word (Pr <b>6.42</b> &amp; Pr <b>6.43</b>).</p> |   |
| <b>Current loop gains (Pr 0.38 {4.13} / Pr 0.39 {4.14})</b>  |   |
| <p>The current loop gains proportional (Kp) and integral (Ki) gains control the response of the current loop to a change in current (torque) demand. The default values give satisfactory operation with most motors. However, for optimal performance in dynamic applications it may be necessary to change the gains to improve the performance. The proportional gain (Pr <b>4.13</b>) is the most critical value in controlling the performance. The values for the current loop gains can be calculated by one of the following:</p> <ul style="list-style-type: none"> <li>• During a stationary or rotating autotune (see <i>Autotune Pr 0.40</i>, earlier in this table) the drive measures the stator resistance (Pr <b>5.17</b>) and transient inductance (Pr <b>5.24</b>) of the motor and calculates the current loop gains.</li> <li>• By setting Pr <b>0.40</b> to 6 the drive will calculate the current loop gains from the values of stator resistance (Pr <b>5.17</b>) and transient inductance (Pr <b>5.24</b>) set in the drive.</li> </ul> <p>This will give a step response with minimum overshoot after a step change of current reference. The proportional gain can be increased by a factor of 1.5 giving a similar increase in bandwidth; however, this gives a step response with approximately 12.5% overshoot. The equation for the integral gain gives a conservative value. In some applications where it is necessary for the reference frame used by the drive to dynamically follow the flux very closely (i.e. high speed closed-loop induction motor applications) the integral gain may need to have a significantly higher value.</p>   |   |

### Speed loop gains (Pr 0.07 {3.10}, Pr 0.08 {3.11}, Pr 0.09 {3.12})

The speed loop gains control the response of the speed controller to a change in speed demand. The speed controller includes proportional (Kp) and integral (Ki) feed forward terms, and a differential (Kd) feedback term. The drive holds two sets of these gains and either set may be selected for use by the speed controller with Pr 3.16. If Pr 3.16 = 0, gains Kp1, Ki1 and Kd1 (Pr 0.07 to Pr 0.09) are used, and if Pr 3.16 = 1, gains Kp2, Ki2 and Kd2 (Pr 3.13 to Pr 3.15) are used. Pr 3.16 may be changed when the drive is enabled or disabled. If the load is predominantly a constant inertia and constant torque, the drive can calculate the required Kp and Ki gains to give a required compliance angle or bandwidth dependant on the setting of Pr 3.17.

#### Proportional gain (Kp), Pr 0.07 {3.10} and Pr 3.13

If the proportional gain has a value and the integral gain is set to zero the controller will only have a proportional term, and there must be a speed error to produce a torque reference. Therefore as the motor load increases there will be a difference between the reference and actual speeds. This effect, called regulation, depends on the level of the proportional gain, the higher the gain the smaller the speed error for a given load. If the proportional gain is too high either the acoustic noise produced by speed feedback quantisation becomes unacceptable, or the closed-loop stability limit is reached.

#### Integral gain (Ki), Pr 0.08 {3.11} and Pr 3.14

The integral gain is provided to prevent speed regulation. The error is accumulated over a period of time and used to produce the necessary torque demand without any speed error. Increasing the integral gain reduces the time taken for the speed to reach the correct level and increases the stiffness of the system, i.e. it reduces the positional displacement produced by applying a load torque to the motor. Unfortunately increasing the integral gain also reduces the system damping giving overshoot after a transient. For a given integral gain the damping can be improved by increasing the proportional gain. A compromise must be reached where the system response, stiffness and damping are all adequate for the application.

#### Differential gain (Kd), Pr 0.09 {3.12} and Pr 3.15

The differential gain is provided in the feedback of the speed controller to give additional damping. The differential term is implemented in a way that does not introduce excessive noise normally associated with this type of function. Increasing the differential term reduces the overshoot produced by under-damping, however, for most applications the proportional and integral gains alone are sufficient.

There are three methods of tuning the speed loop gains dependant on the setting of Pr 3.17:

1. Pr 3.17 = 0, User set-up.

This involves the connecting of an oscilloscope to analogue output 1 to monitor the speed feedback.

Give the drive a step change in speed reference and monitor the response of the drive on the oscilloscope.

The proportional gain (Kp) should be set up initially. The value should be increased up to the point where the speed overshoots and then reduced slightly.

The integral gain (Ki) should then be increased up to the point where the speed becomes unstable and then reduced slightly.

It may now be possible to increase the proportional gain to a higher value and the process should be repeated until the system response matches the ideal response as shown.

The diagram shows the effect of incorrect P and I gain settings as well as the ideal response.

2. Pr 3.17 = 1, Bandwidth set-up

If bandwidth based set-up is required, the drive can calculate Kp and Ki if the following parameters are set up correctly:

Pr 3.20 - Required bandwidth,

Pr 3.21 - Required damping factor,

Pr 5.32 - Motor torque per amp (Kt).

Pr 3.18 - Motor and load inertia. The drive can be made to measure the motor and load inertia by performing an inertia measurement autotune (see Autotune Pr 0.40, earlier in this table).

3. Pr 3.17 = 2, Compliance angle set-up

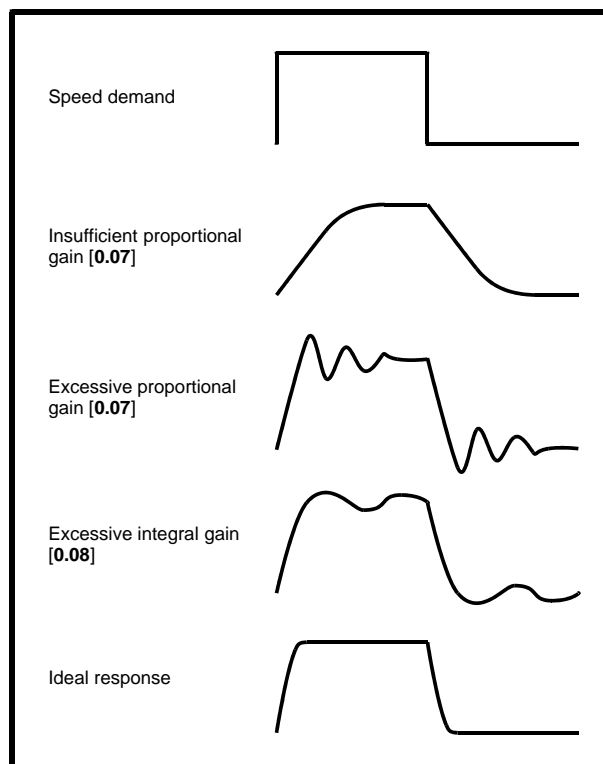
If compliance angle based set-up is required, the drive can calculate Kp and Ki if the following parameters are set up correctly:

Pr 3.19 - Required compliance angle,

Pr 3.21 - Required damping factor,

Pr 5.32 - Motor torque per amp (Kt).

Pr 3.18 - Motor and load inertia. The drive can be made to measure the motor and load inertia by performing an inertia measurement autotune (see Autotune Pr 0.40, earlier in this table).



## 8.2 Maximum motor rated current

The maximum motor rated current allowed by the drive is greater than the maximum Heavy Duty current rating in Pr 11.32. The ratio between the Normal Duty rating and the Heavy Duty rating (Pr 11.32) varies between drive sizes. The values for the Normal and Heavy Duty rating can be found in section 2.1 *Ratings* on page 11.

If the motor rated current (Pr 0.46) is set above the maximum Heavy Duty current rating (Pr 11.32), the current limits and the motor thermal protection scheme are modified (see section 8.3 *Current limits* and section 8.4 *Motor thermal protection*, for more information).

## 8.3 Current limits

The default settings for the current limit parameters for Unidrive SP sizes 1 to 5 are:

- 165% x motor rated current for open loop mode
- 175% x motor rated current for closed loop vector and servo modes (except SP2403 which is 150.1% for open loop, 175% for closed loop vector and 161.2% for servo).

The default settings for the current limit parameters for Unidrive SP size 6 are:

- 138.1% x motor rated current for open loop mode
- 165.7% x motor rated current for closed loop vector mode
- 150% x motor rated current for servo mode

There are three parameters which control the current limits:

- Motoring current limit: power flowing from the drive to the motor
- Regen current limit: power flowing from the motor to the drive
- Symmetrical current limit: current limit for both motoring and regen operation

The lowest of either the motoring and regen current limit, or the symmetrical current limit applies.

The maximum setting of these parameters depends on the values of motor rated current, drive rated current and the power factor.

Increasing the motor rated current (Pr 0.46/5.07) above the Heavy Duty rating (default value), will automatically reduce the current limits in Pr 4.05 to Pr 4.07. If the motor rated current is then set to or below the Heavy Duty rating, the current limits will be left at their reduced values.

The drive can be oversized to permit a higher current limit setting to provide higher accelerating torque as required up to a maximum of 1000%.

## 8.4 Motor thermal protection

Unidrive SP models the temperature of the motor using the motor rated current (Pr 5.07), the thermal time constant (Pr 4.15), whether low speed thermal protection mode has been enabled (Pr 4.25) and the actual current flowing at any point in time. Pr 4.19 gives the estimated motor temperature as a percentage of maximum temperature.

The temperature of the motor (Pr 4.19) as a percentage of maximum temperature, with a constant current magnitude of  $I$ , constant value of  $K$  and constant value of Motor rated current (Pr 5.07) after time  $t$  is given by:

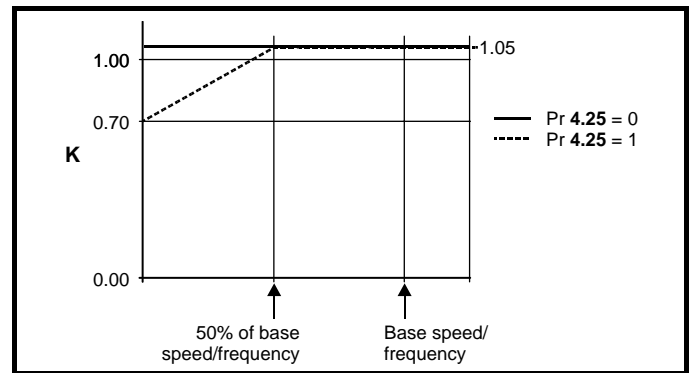
$$\text{Percentage motor temperature (Pr 4.19)} = \left[ \frac{I^2}{(K \times \text{Motor rated current})^2} \right] (1 - e^{-t/\tau}) \times 100\%$$

This assumes that the maximum allowed motor temperature is produced by  $K \times \text{Motor rated current}$  and that  $\tau$  is the thermal time constant of the point in the motor that reaches its maximum allowed temperature first.  $\tau$  is defined by Pr 4.15. If Pr 4.15 has a value between 0.0 and 1.0 the thermal time constant is taken as 1.0.

The value of  $K$  is defined as shown in Figure 8-1 and Figure 8-2.

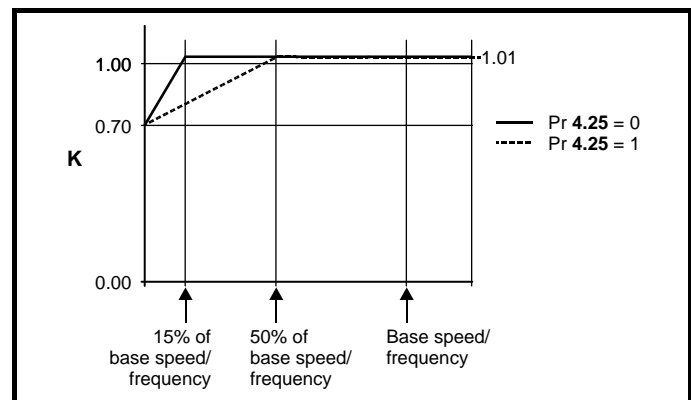
For both Heavy and Normal duty ratings, Pr 4.25 can be used to select two alternative protection characteristics.

Figure 8-1 Motor thermal protection (Heavy Duty)



If Pr 4.25 is 0 the characteristic is for a motor which can operate at rated current over the whole speed range. Induction motors with this type of characteristic normally have forced cooling. If Pr 4.25 is 1 the characteristic is intended for motors where the cooling effect of motor fan reduces with reduced motor speed below 50% of base speed/frequency. The maximum value for  $K$  is 1.05, so that above the knee of the characteristics the motor can operate continuously up to 1.05% current.

Figure 8-2 Motor thermal protection (Normal Duty)



Both settings of Pr 4.25 are intended for motors where the cooling effect of the motor fan reduces with reduced motor speed, but with different speeds below which the cooling effect is reduced. If Pr 4.25 is 0 the characteristic is intended for motors where the cooling effect reduces with motor speed below 15% of base speed/frequency. If Pr 4.25 is 1 the characteristic is intended for motors where the cooling effect reduces with motor speed below 50% of base speed/frequency. The maximum value for  $K$  is 1.01, so that above the knee of the characteristics the motor can operate continuously up to 1.01% current.

When the estimated temperature in Pr 4.19 reaches 100% the drive takes some action depending on the setting of Pr 4.16. If Pr 4.16 is 0, the drive trips when Pr 4.19 reaches 100%. If Pr 4.16 is 1, the current limit is reduced to  $(K - 0.05) \times 100\%$  when Pr 4.19 reaches 100%. The current limit is set back to the user defined level when Pr 4.19 falls below 95%. In servo mode the current magnitude and the active current controlled by the current limits should be similar, and so this system should ensure that the motor operates just below its thermal limit.

The thermal model temperature accumulator is reset to zero at power-up and accumulates the temperature of the motor whilst the drive remains powered-up. If the rated current defined by Pr 5.07 is altered, the accumulator is reset to zero.

The default setting of the thermal time constant (Pr 4.15) is 89s for an induction motor (open loop and closed loop vector), which is equivalent to an overload of 150% for 60s from cold. The default value for a servo motor is 20s, which is equivalent to an overload of 175% for 9s from cold.

The time for the drive to trip from cold with constant motor current is given by:

$$T_{trip} = -(Pr\ 4.15) \times \ln(1 - (K \times Pr\ 5.07 / Pr\ 4.01)^2)$$

Alternatively the thermal time constant can be calculated from the trip time with a given current from:

$$Pr\ 4.15 = -T_{trip} / \ln(1 - (K / Overload)^2)$$

For example, if the drive should trip after supplying 150% overload for 60s with K = 1.05 (Heavy Duty) then:

$$Pr\ 4.15 = -60 / \ln(1 - (1.05 / 1.50)^2) = 89$$

The maximum value for the thermal time constant can be increased up to a maximum value of 400s to allow an increased overload if the motor thermal characteristics permit.

For applications using CT Dynamics Unimotors the thermal time constants can be found in the Unimotor manual.

## 8.5 Switching frequency

The default switching frequency is 3kHz (6kHz in Servo mode), however this can be increased up to a maximum of 16kHz by Pr 5.18 (dependent on drive size). The available switching frequencies are shown below.

**Table 8-1 Available switching frequencies for drives**

| Drive size | Voltage rating  | 3kHz | 4kHz | 6kHz | 8kHz | 12kHz | 16kHz |
|------------|-----------------|------|------|------|------|-------|-------|
| 1          | All             | ✓    | ✓    | ✓    | ✓    | ✓     | ✓     |
| 2          | All             | ✓    | ✓    | ✓    | ✓    | ✓     | ✓     |
| 3          | SP320X          | ✓    | ✓    | ✓    | ✓    | ✓     |       |
|            | SP3401 & SP3402 | ✓    | ✓    | ✓    | ✓    | ✓     | ✓     |
|            | SP3403          | ✓    | ✓    | ✓    | ✓    | ✓     |       |
|            | SP350X          | ✓    | ✓    | ✓    | ✓    |       |       |
| 4          | All             | ✓    | ✓    | ✓    | ✓    |       |       |
| 5          | All             | ✓    | ✓    | ✓    | ✓    |       |       |
| 6          | All             | ✓    | ✓    | ✓    |      |       |       |

**Table 8-2 Available switching frequencies for free standing cubicle drives**

| Drive size | Voltage rating | 3kHz | 4kHz | 6kHz | 8kHz | 12kHz | 16kHz |
|------------|----------------|------|------|------|------|-------|-------|
| 6          | All            | ✓    | ✓    | ✓    |      |       |       |
| 7          | All            | ✓    | ✓    | ✓    |      |       |       |
| 8          | All            | ✓    | ✓    | ✓    |      |       |       |
| 9          | All            | ✓    | ✓    | ✓    |      |       |       |

If switching frequency is increased from 3kHz the following apply:

1. Increased heat loss in the drive, which means that derating to the output current must be applied.  
See the derating tables for switching frequency and ambient temperature in section 12.1.1 *Power and current ratings (Derating for switching frequency and temperature)* on page 257.
2. Reduced heating of the motor - due to improved output waveform quality.
3. Reduced acoustic noise generated by the motor.
4. Increased sample rate on the speed and current controllers. A trade off must be made between motor heating, drive heating and the demands of the application with respect to the sample time required.

**Table 8-3 Sample rates for various control tasks at each switching frequency**

|            | 3, 6, 12 kHz                                | 4, 8, 16 kHz | Open loop                        | Closed loop vector and Servo |
|------------|---|--------------|----------------------------------|------------------------------|
| Level 1    | 3kHz = 167µs<br>6kHz = 83µs<br>12kHz = 83µs | 125µs        | Peak limit                       | Current controllers          |
| Level 2    | 250µs                                       |              | Current limit and ramps          | Speed controller and ramps   |
| Level 3    | 1ms   |              | Voltage controller               |                              |
| Level 4    | 4ms   |              | Time critical user interface     |                              |
| Background |   |              | Non-time critical user interface |                              |

## 8.6 High speed operation

### 8.6.1 Encoder feedback limits

The maximum encoder frequency should be prevented from exceeding 500kHz (or 410kHz for software V01.06.00 and earlier). In closed loop and servo modes the maximum speed that can be entered in to the speed reference clamps (Pr 1.06 and Pr 1.07) can be limited by the drive. This is defined by the following (subject to an absolute maximum of 40,000rpm):

$$\begin{aligned} \text{Maximum speed limit (rpm)} &= \frac{500\text{kHz} \times 60}{\text{ELPR}} \\ &= \frac{3.0 \times 10^7}{\text{ELPR}} \end{aligned}$$

Where:

ELPR is the equivalent encoder lines per revolution and is the number of lines that would be produced by a quadrature encoder.

- Quadrature encoder ELPR = number of lines per revolution
- F and D encoder ELPR = number of lines per revolution / 2
- SINCOS encoder ELPR = number of sine waves per revolution

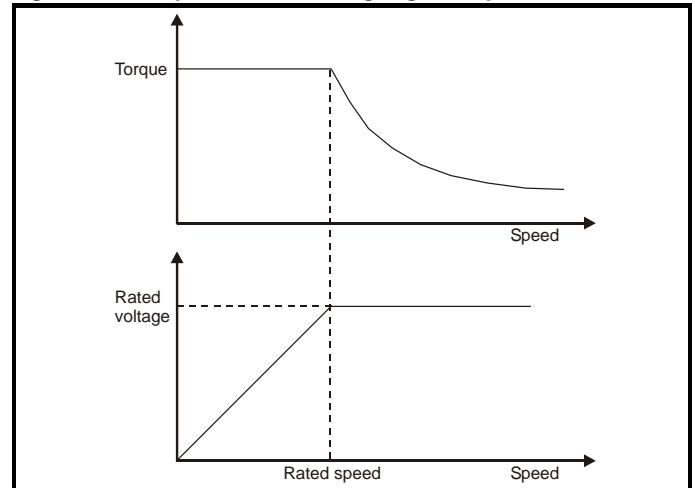
This maximum speed limit is defined by the device selected with the speed feedback selector (Pr 3.26), and the ELPR set for the position feedback device. In closed-loop vector mode it is possible to disable this limit via Pr 3.24, so that the drive can be switched between operation with and without feedback when the speed becomes too high for the feedback device. The maximum speed limit is defined as above when Pr 3.24 = 0 or 1, and is 40,000rpm when Pr 3.24 = 2 or 3.

### 8.6.2 Field weakening (constant power) operation

(Open loop and closed loop vector mode only)

Unidrive SP can be used to run an induction machine above synchronous speed into the constant power region. The speed continues to increase and the available shaft torque reduces. The characteristics below show the torque and output voltage characteristics as the speed is increased above the rated value.

**Figure 8-3 Torque and rated voltage against speed**



Care must be taken to ensure the torque available above base speed is sufficient for the application to run satisfactorily.

The saturation breakpoint parameters (Pr 5.29 and Pr 5.30) found during the autotune in closed loop vector mode ensure the magnetising current is reduced in the correct proportion for the specific motor. (In open loop mode the magnetising current is not actively controlled.)

### 8.6.3 Servo high speed operation

High speed servo mode is enabled by setting Pr 5.22 =1. Care must be taken when using this mode with servo motors to avoid damaging the drive. The voltage produced by the servo motor magnets is proportional to speed. For high speed operation the drive must apply currents to the motor to counter-act the flux produced by the magnets. It is possible to operate the motor at very high speeds that would give a very high motor terminal voltage, but this voltage is prevented by the action of the drive. If however, the drive is disabled (or tripped) when the motor voltages would be higher than the rating of the drive without the currents to counter-act the flux from the magnets, it is possible to damage the drive. If high speed mode is enabled the motor speed must be limited to the levels given in the table below unless an additional hardware protection system is used to limit the voltages applied to the drive output terminals to a safe level.

| Drive voltage rating | Maximum motor speed (rpm)      | Maximum safe line to line voltage at the motor terminals (V rms) |
|----------------------|--------------------------------|--|
| 200                  | $400 / (K_e \times \sqrt{2})$  | $400 / \sqrt{2}$   |
| 400                  | $800 / (K_e \times \sqrt{2})$  | $800 / \sqrt{2}$   |
| 575                  | $955 / (K_e \times \sqrt{2})$  | $955 / \sqrt{2}$   |
| 690                  | $1145 / (K_e \times \sqrt{2})$ | $1145 / \sqrt{2}$  |

$K_e$  is the ratio between r.m.s. line to line voltage produced by the motor and the speed in V/rpm. Care must also be taken not to de-magnetise the motor. The motor manufacturer should always be consulted before using this mode.

### 8.6.4 Switching frequency

With a default switching frequency of 3 kHz the maximum output frequency should be limited to 250 Hz. Ideally a minimum ratio of 12:1 should be maintained between the output frequency and the switching frequency. This ensures the number of switchings per cycle is sufficient to ensure the output waveform quality is maintained at a minimum level. If this is not possible, quasi-square switching should be enabled (Pr 5.20 =1). The output waveform will be quasi square above base speed ensuring a symmetrical output waveform, which results in a better quality output than would otherwise result.

### 8.6.5 Maximum speed / frequency

In open loop mode the maximum frequency is 3,000 Hz.

In closed loop vector mode the maximum output frequency is 600 Hz.

In servo mode the maximum output frequency is 1250Hz, however the speed is limited by the voltage constant ( $K_e$ ) of the motor.  $K_e$  is a specific constant for the servo motor being used. It can normally be found on the motor data sheet in V/krpm (volts per 1,000rpm).

### 8.6.6 Quasi-Square wave (open-loop only)

The maximum output voltage level of the drive is normally limited to an equivalent of the drive input voltage minus voltage drops within the drive (the drive will also retain a few percent of the voltage in order to maintain current control). If the motor rated voltage is set at the same level as the supply voltage, some pulse deletion will occur as the drive output voltage approaches the rated voltage level. If Pr 5.20 (Quasi-square wave enable) is set to 1 the modulator will allow over modulation, so that as the output frequency increases beyond the rated frequency the voltage continues to increase above the rated voltage. The modulation depth will increase beyond unity; first producing trapezoidal and then quasi-square waveforms.

This can be used for example:

- To obtain high output frequencies with a low switching frequency which would not be possible with space vector modulation limited to unity modulation depth,
- or
- In order to maintain a higher output voltage with a low supply voltage.

The disadvantage is that the machine current will be distorted as the modulation depth increases above unity, and will contain a significant amount of low order odd harmonics of the fundamental output frequency. The additional low order harmonics cause increased losses and heating in the motor.

# 9 SMARTCARD operation

## 9.1 Introduction

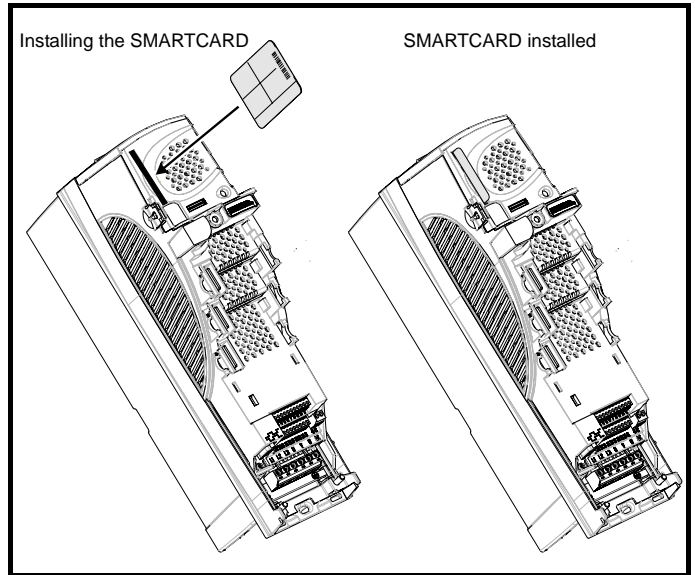
This is a standard feature that enables simple configuration of parameters in a variety of ways. The SMARTCARD can be used for:

- Parameter cloning between drives
- Saving whole drive parameter sets
- Saving 'differences from default' parameter sets
- Storing Onboard PLC programs
- Automatically saving all user parameter changes for maintenance purposes
- Loading complete motor map parameters

The SMARTCARD is located at the top of the module under the drive display (if fitted) on the left-hand side. Ensure the SMARTCARD is inserted with the contacts facing the right-hand side of the drive.

The drive only communicates with the SMARTCARD when commanded to read or write, meaning the card may be "hot swapped".

Figure 9-1 Installation of the SMARTCARD



### Encoder phase angle (servo mode only)

With drive software version V01.08.00 onwards, the encoder phase angles in Pr 3.25 and Pr 21.20 are cloned to the SMARTCARD when using any of the SMARTCARD transfer methods.

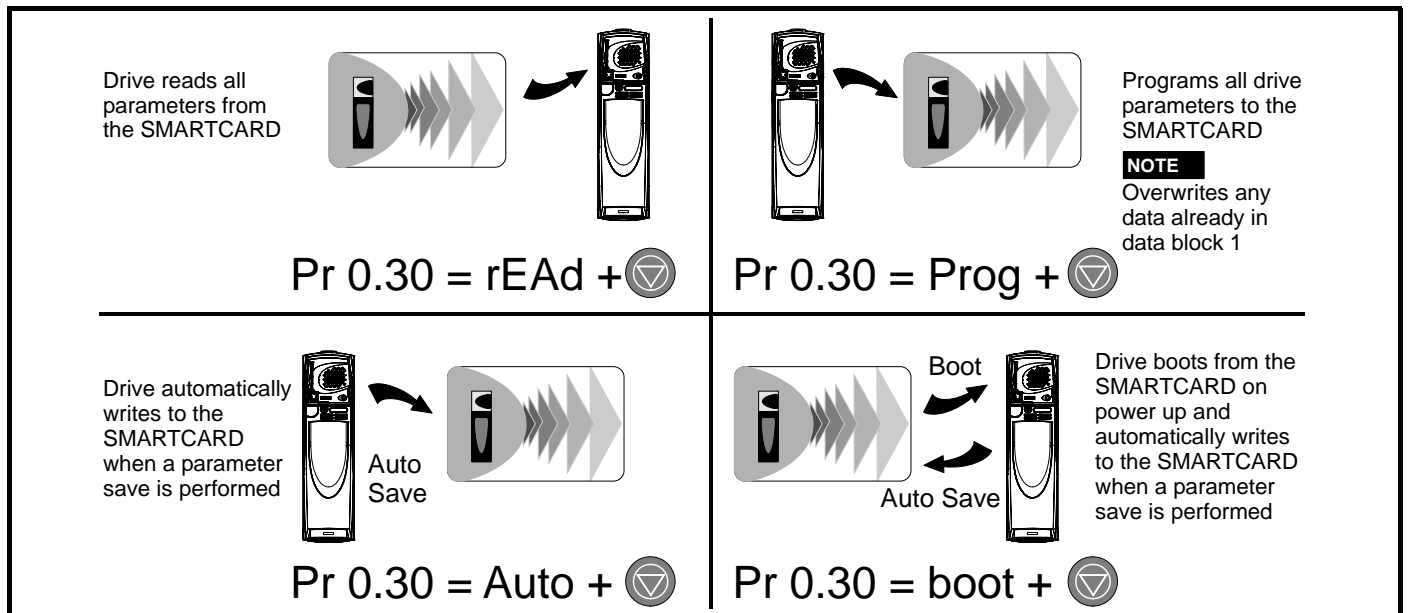
With drive software version V01.05.00 to V01.07.01, the encoder phase angles in Pr 3.25 and Pr 21.20 are only cloned to the SMARTCARD when using either Pr 0.30 set to Prog (2) or Pr xx.00 set to 3yyy.

This is useful when the SMARTCARD is used to back-up the parameter set of a drive but caution should be used if the SMARTCARD is used to transfer parameter sets between drives. Unless the encoder phase angle of the servo motor connected to the destination drive is known to be the same as the servo motor connected to the source drive, an autotune should be performed or the encoder phase angle should be entered manually into Pr 3.25 (or Pr 21.20). If the encoder phase angle is incorrect the drive may lose control of the motor resulting in an O.SPd or Enc10 trip when the drive is enabled.

With drive software version V01.04.00 and earlier, or when using software version V01.05.00 to V01.07.01 and Pr xx.00 set to 4yyy is used, then the encoder phase angles in Pr 3.25 and Pr 21.20 are not cloned to the SMARTCARD. Therefore, Pr 3.25 and Pr 21.20 in the destination would not be changed during a transfer of this data block from the SMARTCARD.

### Easy saving and reading

Figure 9-2 Basic SMARTCARD operation



The SMARTCARD has 999 individual data block locations. Each individual location from 1 to 499 can be used to store data until the capacity of the SMARTCARD is used. With software V01.07.00 and later the drive can support SMARTCARDS with a capacity of between 4kB and 512kB. With software V01.06.02 and earlier the drive can support SMARTCARDS with a capacity of 4kB.

The data block locations of the SMARTCARD are arranged to have the following usage:

**Table 9-1 SMARTCARD data blocks**

| Data Block | Type         | Example Use         |
|------------|--------------|---------------------|
| 1 to 499   | Read / Write | Application set ups |
| 500 to 999 | Read Only    | Macros              |

'Differences from default' parameter sets will be much smaller than whole parameter sets and thus take up a lot less memory as most applications only require a few parameters to be changed from the default setting.

The whole card may be protected from writing or erasing by setting the read-only flag as detailed section 9.2.9 9888 / 9777 - *Setting and clearing the SMARTCARD read only flag* on page 153.

Data transfer to or from the SMARTCARD is indicated by one the following:

- SM-Keypad: The decimal point after the fourth digit in the upper display will flash.
- SM-Keypad Plus: The symbol 'CC' will appear in the lower left hand corner of the display

The card should not be removed during data transfer, as the drive will produce a trip. If this occurs then either the transfer should be reattempted or in the case of a card to drive transfer, default parameters should be loaded.

## 9.2 Transferring data

Data transfer, erasing and protecting the information is performed by entering a code in Pr **xx.00** and then resetting the drive as shown in Table 9-2.

**Table 9-2 SMARTCARD codes**

| Code | Action   |
|------|--|
| 2001 | Transfer drive parameters as difference from defaults to a bootable SMARTCARD block in data block number 001 |
| 3yyy | Transfer drive parameters to a SMARTCARD block number yyy  |
| 4yyy | Transfer drive data as difference from defaults to SMARTCARD block number yyy                                |
| 5yyy | Transfer drive Onboard PLC program to SMARTCARD block number yyy   |
| 6yyy | Transfer SMARTCARD data block yyy to the drive   |
| 7yyy | Erase SMARTCARD data block yyy   |
| 8yyy | Compare drive parameters with block yyy  |
| 9555 | Clear SMARTCARD warning suppression flag (V01.07.00 and later)   |
| 9666 | Set SMARTCARD warning suppression flag (V01.07.00 and later)   |
| 9777 | Clear SMARTCARD read-only flag   |
| 9888 | Set SMARTCARD read-only flag   |
| 9999 | Erase SMARTCARD  |

Where yyy indicates the block number 001 to 999. See Table 9-1 for restrictions on block numbers.

### NOTE

If the read only flag is set then only codes 6yyy or 9777 are effective.

### 9.2.1 Writing to the SMARTCARD

#### 3yyy - Transfer data to the SMARTCARD

The data block contains the complete parameter data from the drive, i.e. all user save (US) parameters except parameters with the NC coding bit set. Power-down save (PS) parameters are not transferred to the SMARTCARD.

With software V01.06.02 and earlier, a save must have been performed on the drive to transfer the parameters from the drive RAM to the EEPROM before the transfer to the SMARTCARD is carried out.

#### 4yyy - Write default differences to a SMARTCARD

The data block only contains the parameter differences from the last time default settings were loaded.

Six bytes are required for each parameter difference. The data density is not as high as when using the 3yyy transfer method as described in the previous section, but in most cases the number of differences from default is small and the data blocks are therefore smaller. This method can be used for creating drive macros. Power-down save (PS) parameters are not transferred to the SMARTCARD.

The data block format is different depending on the software version. The data block holds the following parameters:

#### Software V01.06.02 and earlier

All user save (US) parameters, except those with the NC (Not Cloned) coding bit set or those that do not have a default value, can be transferred to the SMARTCARD.

#### Software V01.07.xx

All user save (US) parameters, except those with the NC (Not Cloned) coding bit set or those that do not have a default value, can be transferred to the SMARTCARD. In addition to these parameters all menu 20 parameters (except Pr **20.00**), can be transferred to the SMARTCARD even though they are not user save parameters and have the NC coding bit set.

#### Software V01.08.00 onwards

All user save (US) parameters including those that do not have a default value (i.e. Pr **3.25** or Pr **21.20 Encoder phase angle**), but not including those with the NC (Not Cloned) coding bit set can be transferred to the SMARTCARD. In addition to these parameters all menu 20 parameters (except Pr **20.00**), can be transferred to the SMARTCARD even though they are not user save parameters and have the NC coding bit set.

It is possible to transfer parameters between drive with each of the different formats, however, the data block compare function does not work with data produced by different formats.

#### Writing a parameter set to the SMARTCARD (Pr 11.42 = Prog (2))

Setting Pr **11.42** to Prog (2) and resetting the drive will save the parameters to the SMARTCARD, i.e. this is equivalent to writing 3001 to Pr **xx.00**. All SMARTCARD trips apply except 'C.Chg'. If the data block already exists it is automatically overwritten. When the action is complete this parameter is automatically reset to nonE (0).

### 9.2.2 Reading from the SMARTCARD

#### 6yyy - Read default differences from a SMARTCARD

When the data is transferred back to a drive, using 6yyy in Pr **xx.00**, it is transferred to the drive RAM and the drive EEPROM. A parameter save is not required to retain the data after power-down. Set up data for any Solutions Modules fitted are stored on the card and are transferred to the destination drive. If the Solutions Modules are different between the source and destination drive, the menus for the slots where the Solutions Module categories are different are not updated from the card and will contain their default values after the cloning action. The drive will produce a 'C.Optn' trip if the Solutions Modules fitted to the source and destination drive are different or are in different slots. If the data is being transferred to a drive of a different voltage or current rating a 'C.rtg' trip will occur.

The following rating dependent parameters (RA coding bit set) will not be written to the destination drive and will contain their default values after the cloning action:

- Pr 2.08 Standard ramp voltage
- Pr 4.05 to Pr 4.07 and Pr 21.27 to Pr 21.29 Current limits
- Pr 4.24, User current maximum scaling
- Pr 5.07, Pr 21.07 Motor rated current
- Pr 5.09, Pr 21.09 Motor rated voltage
- Pr 5.10, Pr 21.10 Rated power factor
- Pr 5.17, Pr 21.12 Stator resistance
- Pr 5.18 Switching frequency
- Pr 5.23, Pr 21.13 Voltage offset
- Pr 5.24, Pr 21.14 Transient inductance
- Pr 5.25, Pr 21.24 Stator inductance
- Pr 6.06 DC injection braking current
- Pr 6.48 Mains loss ride through detection level

### Reading a parameter set from the SMARTCARD (Pr 11.42 = rEAd (1))

Setting Pr 11.42 to rEAd (1) and resetting the drive will transfer the parameters from the card into the drive parameter set and the drive EEPROM, i.e. this is equivalent to writing 6001 to Pr xx.00. All SMARTCARD trips apply. Once the parameters are successfully copied this parameter is automatically reset to nonE (0). Parameters are saved to the drive EEPROM after this action is complete.

#### NOTE

This operation is only performed if data block 1 on the card is a full parameter set (3yyy transfer) and not a default difference file (4yyy transfer). If block 1 does not exist a 'C.dAt' trip occurs.

### 9.2.3 Auto saving parameter changes (Pr 11.42 = Auto (3))

This setting causes the drive to automatically save any changes made to menu 0 parameters on the drive to the SMARTCARD. The latest menu 0 parameter set in the drive is therefore always backed up on the SMARTCARD. Changing Pr 11.42 to Auto (3) and resetting the drive will immediately save the complete parameter set from the drive to the card, i.e. all user save (US) parameters except parameters with the NC coding bit set. Once the whole parameter set is stored only the individual modified menu 0 parameter setting is updated.

Advanced parameter changes are only saved to the card when Pr xx.00 is set to a 1000 and the drive reset.

All SMARTCARD trips apply, except 'C.Chg'. If the data block already contains information it is automatically overwritten.

If the card is removed when Pr 11.42 is set to 3 Pr 11.42 is then automatically set to nonE (0).

When a new SMARTCARD is fitted Pr 11.42 must be set back to Auto (3) by the user and the drive reset so the complete parameter set is rewritten to the new SMARTCARD if auto mode is still required.

When Pr 11.42 is set to Auto (3) and the parameters in the drive are saved, the SMARTCARD is also updated, therefore the SMARTCARD becomes a copy of the drives stored configuration.

At power up, if Pr 11.42 is set to Auto (3), the drive will save the complete parameter set to the SMARTCARD. The drive will display 'cArd' during this operation. This is done to ensure that if a user puts a new SMARTCARD in during power down the new SMARTCARD will have the correct data.

#### NOTE

When Pr 11.42 is set to Auto (3) the setting of Pr 11.42 itself is saved to the drive EEPROM but NOT to the SMARTCARD.

### 9.2.4 Booting up from the SMARTCARD on every power up (Pr 11.42 = boot (4))

When Pr 11.42 is set to boot (4) the drive operates the same as Auto mode except when the drive is powered-up. The parameters on the SMARTCARD will be automatically transferred to the drive at power up if the following are true:

- A card is inserted in the drive
- Parameter data block 1 exists on the card
- The data in block 1 is type 1 to 5 (as defined in Pr 11.38)
- Pr 11.42 on the card set to boot (4)

The drive will display 'boot' during this operation. If the drive mode is

different from that on the card, the drive gives a 'C.Typ'. trip and the data is not transferred.

If 'boot' mode is stored on the cloning SMARTCARD this makes the cloning SMARTCARD the master device. This provides a very fast and efficient way of re-programming a number of drives.

If data block 1 contains a bootable parameter set and data block 2 contains an Onboard PLC program (type 17 as defined in Pr 11.38), then if the drive software version is V01.07.00 and later, the onboard PLC program will be transferred to the drive at power up along with the parameter set in data block 1.

#### NOTE

'Boot' mode is saved to the card, but when the card is read, the value of Pr 11.42 is not transferred to the drive.

### 9.2.5 Booting up from the SMARTCARD on every power up (Pr xx.00 = 2001), software V01.08.00 and later

It is possible to create a difference from default bootable file by setting Pr xx.00 to 2001 and resetting the drive. This type of file causes the drive to behave in the same way at power-up as a file created with boot mode set up with Pr 11.42. The difference from the default file is that it has the added advantage of including menu 20 parameters.

Setting Pr xx.00 to 2001 will overwrite data block 1 on the card if it already exists.

If a data block 2 exists and contains an Onboard PLC program (type 17 as defined in Pr 11.38), this will also be loaded after the parameters have been transferred

A bootable difference from default file can only be created in one operation and parameters cannot be added as they are save via menu 0.

### 9.2.6 8yyy - Comparing the drive full parameter set with the SMARTCARD values

Setting 8yyy in Pr xx.00, will compare the SMARTCARD file with the data in the drive. If the compare is successful Pr xx.00 is simply set to 0. If the compare fails a 'C.cpr' trip is initiated.

### 9.2.7 7yyy / 9999 - Erasing data from the SMARTCARD

Data can be erased from the SMART CARD either one block at a time or blocks 1 to 499 in one go.

- Setting 7yyy in Pr xx.00 will erase SMART CARD data block yyy.
- Setting 9999 in Pr xx.00 will erase SMART CARD data blocks 1 to 499

### 9.2.8 9666 / 9555 - Setting and clearing the SMARTCARD warning suppression flag (V01.07.00 and later)

If the Solutions Modules fitted to the source and destination drive are different or are in different slots the drive will produce a 'C.Optn' trip. If the data is being transferred to a drive of a different voltage or current rating a 'C.rtg' trip will occur. It is possible to suppress these trips by setting the warning suppression flag. If this flag is set the drive will not trip if the Solutions Module(s) or drive ratings are different between the source and destination drives. The Solutions Module or rating dependent parameters will not be transferred.

- Setting 9666 in Pr xx.00 will set the warning suppression flag
- Setting 9555 in Pr xx.00 will clear the warning suppression flag

### 9.2.9 9888 / 9777 - Setting and clearing the SMARTCARD read only flag

The SMART CARD may be protected from writing or erasing by setting the read only flag. If an attempt is made to write or erase a data block when the read only flag is set, a 'C.rdo' trip is initiated. When the read only flag is set only codes 6yyy or 9777 are effective.

- Setting 9888 in Pr xx.00 will set the read only flag
- Setting 9777 in Pr xx.00 will clear the read only flag.

### 9.3 Data block header information

Each data block stored on a SMARTCARD has header information detailing the following:

- A number which identifies the block (Pr 11.37)
- The type of data stored in the block (Pr 11.38)
- The drive mode if the data is parameter data (Pr 11.38)
- The version number (Pr 11.39)
- The checksum (Pr 11.40)
- The read-only flag
- The warning suppression flag (V01.07.00 and later)

The header information for each data block which has been used can be viewed in Pr 11.38 to Pr 11.40 by increasing or decreasing the data block number set in Pr 11.37.

#### Software V01.07.00 and later

If Pr 11.37 is set to 1000 the checksum parameter (Pr 11.40) shows the number of bytes left on the card in 16 byte pages.

If Pr 11.37 is set to 1001 the checksum parameter (Pr 11.40) shows the total capacity of the card in 16 byte pages. Therefore, for a 4kB card this parameter would show 254.

If Pr 11.37 is set to 1002 the checksum parameter (Pr 11.40) shows the state of the read-only (bit 0) and warning suppression flags (bit 1).

If there is no data on the card Pr 11.37 can only have values of 0 or 1,000 to 1,002.

#### Software V01.06.02 and earlier

If Pr 11.37 is set to 1000 the checksum parameter (Pr 11.40) shows the number of bytes left on the card. If there is no data on the card Pr 11.37 can only have values of 0 or 1,000.

The version number is intended to be used when data blocks are used as drive macros. If a version number is to be stored with a data block, Pr 11.39 should be set to the required version number before the data is transferred. Each time Pr 11.37 is changed by the user the drive puts the version number of the currently viewed data block in Pr 11.39.

If the destination drive has a different drive mode to the parameters on the card, the drive mode will be changed by the action of transferring parameters from the card to the drive.

The actions of erasing a card, erasing a file, changing a menu 0 parameter, or inserting a new card will effectively set Pr 11.37 to 0 or the lowest file number in the card.

### 9.4 SMARTCARD parameters

Table 9-3 Key to parameter table coding

| RW | Read / Write     | RO  | Read only     | Uni | Unipolar    |
|----|------------------|-----|---------------|-----|-------------|
| Bi | Bi-polar         | Bit | Bit parameter | Txt | Text string |
| FI | Filtered         | DE  | Destination   | NC  | Not cloned  |
| RA | Rating dependent | PT  | Protected     | US  | User save   |
| PS | Power down save  |     |               |     |             |

| 11.36 {0.29} SMARTCARD parameter data previously loaded |          |
|---|----------|
| RO  | Uni      |
| ↕   | 0 to 999 |
| ⇒   | 0        |

This parameter shows the number of the data block last transferred from a SMARTCARD to the drive.

| 11.37 SMARTCARD data number |            |
|-----------------------------|------------|
| RW                          | Uni        |
| ↕                           | 0 to 1,002 |
| ⇒                           | 0          |

This parameter should have the data block number entered for which the user would like information displayed in Pr 11.38, Pr 11.39 and Pr 11.40.

| 11.38 SMARTCARD data type/mode |         |
|--------------------------------|---------|
| RO                             | Txt     |
| ↕                              | 0 to 18 |
| ⇒                              |         |

Gives the type/mode of the data block selected with Pr 11.37:

| Pr 11.38 | String   | Type/mode                                      | Data stored                          |
|----------|----------|--|--------------------------------------|
| 0        | FrEE     | Value when Pr 11.37 = 0, 1,000, 1,001 or 1,002 | Data from EEPROM                     |
| 1        |          | Reserved                                       |                                      |
| 2        | 3OpEn.LP | Open-loop mode parameters                      |                                      |
| 3        | 3CL.VECt | Closed-loop vector mode parameters             |                                      |
| 4        | 3SErVO   | Servo mode parameters                          |                                      |
| 5        | 3rEgEn   | Regen mode parameters                          | Defaults last loaded and differences |
| 6 to 8   | 3Un      | Unused   |                                      |
| 9        |          | Reserved                                       |                                      |
| 10       | 4OpEn.LP | Open-loop mode parameters                      |                                      |
| 11       | 4CL.VECt | Closed-loop vector mode parameters             |                                      |
| 12       | 4SErVO   | Servo mode parameters                          |                                      |
| 13       | 4rEgEn   | Regen mode parameters                          |                                      |
| 14 to 16 | 4Un      | Unused   |                                      |
| 17       | LAddEr   | Onboard PLC program                            |                                      |
| 18       | Option   | A Solutions Module file                        |                                      |

| 11.39 SMARTCARD data version |            |
|------------------------------|------------|
| RW                           | Uni        |
| ↕                            | 0 to 9,999 |
| ⇒                            | 0          |

Gives the version number of the data block selected in Pr 11.37.

| 11.40 SMARTCARD data checksum |             |
|-------------------------------|-------------|
| RO                            | Uni         |
| ↕                             | 0 to 65,335 |
| ⇒                             |             |

Gives the checksum of the data block selected in Pr 11.37.

| 11.42 {0.30} Parameter cloning |          |
|--------------------------------|----------|
| RW                             | Txt      |
| ↕                              | 0 to 4   |
| ⇒                              | nonE (0) |

#### NOTE





If Pr 11.42 is equal to 1 or 2, this value is not transferred to the drive or saved to the EEPROM. If Pr 11.42 is set to a 3 or 4 the value is transferred.

- nonE (0) = Inactive
- rEAd (1) = Read parameter set from the SMARTCARD
- Prog (2) = Programming a parameter set to the SMARTCARD
- Auto (3) = Auto save
- boot (4) = Boot mode

## 9.5 SMARTCARD trips

After an attempt to read, write or erase data to or from a SMARTCARD a trip may occur if there has been a problem with the command. The following trips indicate various problems as detailed in Table 9-4.

**Table 9-4 Trip conditions**

| Trip                | Diagnosis   |           |          |      |                       |                     |                |      |                              |             |                     |             |                     |             |                    |             |                   |      |                     |             |                |             |                      |             |                   |      |                              |      |   |
|---------------------|---|-----------|----------|------|-----------------------|---------------------|----------------|------|------------------------------|-------------|---------------------|-------------|---------------------|-------------|--------------------|-------------|-------------------|------|---------------------|-------------|----------------|-------------|----------------------|-------------|-------------------|------|------------------------------|------|---|
| <b>C.Acc</b>        | <b>SMARTCARD trip: SMARTCARD Read / Write fail</b>  |           |          |      |                       |                     |                |      |                              |             |                     |             |                     |             |                    |             |                   |      |                     |             |                |             |                      |             |                   |      |                              |      |   |
| 185                 | Check SMARTCARD is fitted / located correctly<br>Replace SMARTCARD  |           |          |      |                       |                     |                |      |                              |             |                     |             |                     |             |                    |             |                   |      |                     |             |                |             |                      |             |                   |      |                              |      |   |
| <b>C.boot</b>       | <b>SMARTCARD trip: The menu 0 parameter modification cannot be saved to the SMARTCARD because the necessary file has not been created on the SMARTCARD</b>  |           |          |      |                       |                     |                |      |                              |             |                     |             |                     |             |                    |             |                   |      |                     |             |                |             |                      |             |                   |      |                              |      |   |
| 177                 | A write to a menu 0 parameter has been initiated via the keypad with Pr 11.42 set to auto(3) or boot(4), but the necessary file on the SMARTCARD has not been created<br>Ensure that Pr 11.42 is correctly set and reset the drive to create the necessary file on the SMARTCARD<br>Re-attempt the parameter write to the menu 0 parameter  |           |          |      |                       |                     |                |      |                              |             |                     |             |                     |             |                    |             |                   |      |                     |             |                |             |                      |             |                   |      |                              |      |   |
| <b>C.bUSY</b>       | <b>SMARTCARD trip: SMARTCARD can not perform the required function as it is being accessed by a Solutions Module</b>  |           |          |      |                       |                     |                |      |                              |             |                     |             |                     |             |                    |             |                   |      |                     |             |                |             |                      |             |                   |      |                              |      |   |
| 178                 | Wait for the Solutions Module to finish accessing the SMARTCARD and then re-attempt the required function   |           |          |      |                       |                     |                |      |                              |             |                     |             |                     |             |                    |             |                   |      |                     |             |                |             |                      |             |                   |      |                              |      |   |
| <b>C.Chg</b>        | <b>SMARTCARD trip: Data location already contains data</b>  |           |          |      |                       |                     |                |      |                              |             |                     |             |                     |             |                    |             |                   |      |                     |             |                |             |                      |             |                   |      |                              |      |   |
| 179                 | Erase data in data location<br>Write data to an alternative data location   |           |          |      |                       |                     |                |      |                              |             |                     |             |                     |             |                    |             |                   |      |                     |             |                |             |                      |             |                   |      |                              |      |   |
| <b>C.Cpr</b>        | <b>SMARTCARD trip: The values stored in the drive and the values in the data block on the SMARTCARD are different</b>   |           |          |      |                       |                     |                |      |                              |             |                     |             |                     |             |                    |             |                   |      |                     |             |                |             |                      |             |                   |      |                              |      |   |
| 188                 | Press the red  reset button  |           |          |      |                       |                     |                |      |                              |             |                     |             |                     |             |                    |             |                   |      |                     |             |                |             |                      |             |                   |      |                              |      |   |
| <b>C.dat</b>        | <b>SMARTCARD trip: Data location specified does not contain any data</b>  |           |          |      |                       |                     |                |      |                              |             |                     |             |                     |             |                    |             |                   |      |                     |             |                |             |                      |             |                   |      |                              |      |   |
| 183                 | Ensure data block number is correct   |           |          |      |                       |                     |                |      |                              |             |                     |             |                     |             |                    |             |                   |      |                     |             |                |             |                      |             |                   |      |                              |      |   |
| <b>C.Err</b>        | <b>SMARTCARD trip: SMARTCARD data is corrupted</b>  |           |          |      |                       |                     |                |      |                              |             |                     |             |                     |             |                    |             |                   |      |                     |             |                |             |                      |             |                   |      |                              |      |   |
| 182                 | Ensure the card is located correctly<br>Erase data and retry<br>Replace SMARTCARD   |           |          |      |                       |                     |                |      |                              |             |                     |             |                     |             |                    |             |                   |      |                     |             |                |             |                      |             |                   |      |                              |      |   |
| <b>C.Full</b>       | <b>SMARTCARD trip: SMARTCARD full</b>   |           |          |      |                       |                     |                |      |                              |             |                     |             |                     |             |                    |             |                   |      |                     |             |                |             |                      |             |                   |      |                              |      |   |
| 184                 | Delete a data block or use a different SMARTCARD  |           |          |      |                       |                     |                |      |                              |             |                     |             |                     |             |                    |             |                   |      |                     |             |                |             |                      |             |                   |      |                              |      |   |
| <b>C.Optn</b>       | <b>SMARTCARD trip: Solutions Modules fitted are different between source drive and destination drive</b>  |           |          |      |                       |                     |                |      |                              |             |                     |             |                     |             |                    |             |                   |      |                     |             |                |             |                      |             |                   |      |                              |      |   |
| 180                 | Ensure correct Solutions Modules are fitted<br>Ensure Solutions Modules are in the same Solutions Module slot<br>Press the red  reset button   |           |          |      |                       |                     |                |      |                              |             |                     |             |                     |             |                    |             |                   |      |                     |             |                |             |                      |             |                   |      |                              |      |   |
| <b>C.rdo</b>        | <b>SMARTCARD trip: SMARTCARD has the Read only bit set</b>  |           |          |      |                       |                     |                |      |                              |             |                     |             |                     |             |                    |             |                   |      |                     |             |                |             |                      |             |                   |      |                              |      |   |
| 181                 | Enter 9777 in Pr xx.00 to allow SMARTCARD Read / Write access<br>Ensure card is not writing to data locations 500 to 999  |           |          |      |                       |                     |                |      |                              |             |                     |             |                     |             |                    |             |                   |      |                     |             |                |             |                      |             |                   |      |                              |      |   |
| <b>C.rtg</b>        | <b>SMARTCARD trip: SMARTCARD attempting to change the destination drive ratings<br/>No drive rating parameters have been transferred</b>  |           |          |      |                       |                     |                |      |                              |             |                     |             |                     |             |                    |             |                   |      |                     |             |                |             |                      |             |                   |      |                              |      |   |
| 186                 | Press the red  reset button<br>Drive rating parameters are: <table border="1" data-bbox="300 1381 976 1797"> <thead> <tr> <th>Parameter</th> <th>Function</th> </tr> </thead> <tbody> <tr> <td>2.08</td> <td>Standard ramp voltage</td> </tr> <tr> <td>4.05/6/7, 21.27/8/9</td> <td>Current limits</td> </tr> <tr> <td>4.24</td> <td>User current maximum scaling</td> </tr> <tr> <td>5.07, 21.07</td> <td>Motor rated current</td> </tr> <tr> <td>5.09, 21.09</td> <td>Motor rated voltage</td> </tr> <tr> <td>5.10, 21.10</td> <td>Rated power factor</td> </tr> <tr> <td>5.17, 21.12</td> <td>Stator resistance</td> </tr> <tr> <td>5.18</td> <td>Switching frequency</td> </tr> <tr> <td>5.23, 21.13</td> <td>Voltage offset</td> </tr> <tr> <td>5.24, 21.14</td> <td>Transient inductance</td> </tr> <tr> <td>5.25, 21.24</td> <td>Stator inductance</td> </tr> <tr> <td>6.06</td> <td>DC injection braking current</td> </tr> <tr> <td>6.48</td> <td>Mains loss ride through detection level</td> </tr> </tbody> </table> <p>The above parameters will be set to their default values.</p> | Parameter | Function | 2.08 | Standard ramp voltage | 4.05/6/7, 21.27/8/9 | Current limits | 4.24 | User current maximum scaling | 5.07, 21.07 | Motor rated current | 5.09, 21.09 | Motor rated voltage | 5.10, 21.10 | Rated power factor | 5.17, 21.12 | Stator resistance | 5.18 | Switching frequency | 5.23, 21.13 | Voltage offset | 5.24, 21.14 | Transient inductance | 5.25, 21.24 | Stator inductance | 6.06 | DC injection braking current | 6.48 | Mains loss ride through detection level |
| Parameter           | Function  |           |          |      |                       |                     |                |      |                              |             |                     |             |                     |             |                    |             |                   |      |                     |             |                |             |                      |             |                   |      |                              |      |   |
| 2.08                | Standard ramp voltage   |           |          |      |                       |                     |                |      |                              |             |                     |             |                     |             |                    |             |                   |      |                     |             |                |             |                      |             |                   |      |                              |      |   |
| 4.05/6/7, 21.27/8/9 | Current limits  |           |          |      |                       |                     |                |      |                              |             |                     |             |                     |             |                    |             |                   |      |                     |             |                |             |                      |             |                   |      |                              |      |   |
| 4.24                | User current maximum scaling  |           |          |      |                       |                     |                |      |                              |             |                     |             |                     |             |                    |             |                   |      |                     |             |                |             |                      |             |                   |      |                              |      |   |
| 5.07, 21.07         | Motor rated current   |           |          |      |                       |                     |                |      |                              |             |                     |             |                     |             |                    |             |                   |      |                     |             |                |             |                      |             |                   |      |                              |      |   |
| 5.09, 21.09         | Motor rated voltage   |           |          |      |                       |                     |                |      |                              |             |                     |             |                     |             |                    |             |                   |      |                     |             |                |             |                      |             |                   |      |                              |      |   |
| 5.10, 21.10         | Rated power factor  |           |          |      |                       |                     |                |      |                              |             |                     |             |                     |             |                    |             |                   |      |                     |             |                |             |                      |             |                   |      |                              |      |   |
| 5.17, 21.12         | Stator resistance   |           |          |      |                       |                     |                |      |                              |             |                     |             |                     |             |                    |             |                   |      |                     |             |                |             |                      |             |                   |      |                              |      |   |
| 5.18                | Switching frequency   |           |          |      |                       |                     |                |      |                              |             |                     |             |                     |             |                    |             |                   |      |                     |             |                |             |                      |             |                   |      |                              |      |   |
| 5.23, 21.13         | Voltage offset  |           |          |      |                       |                     |                |      |                              |             |                     |             |                     |             |                    |             |                   |      |                     |             |                |             |                      |             |                   |      |                              |      |   |
| 5.24, 21.14         | Transient inductance  |           |          |      |                       |                     |                |      |                              |             |                     |             |                     |             |                    |             |                   |      |                     |             |                |             |                      |             |                   |      |                              |      |   |
| 5.25, 21.24         | Stator inductance   |           |          |      |                       |                     |                |      |                              |             |                     |             |                     |             |                    |             |                   |      |                     |             |                |             |                      |             |                   |      |                              |      |   |
| 6.06                | DC injection braking current  |           |          |      |                       |                     |                |      |                              |             |                     |             |                     |             |                    |             |                   |      |                     |             |                |             |                      |             |                   |      |                              |      |   |
| 6.48                | Mains loss ride through detection level   |           |          |      |                       |                     |                |      |                              |             |                     |             |                     |             |                    |             |                   |      |                     |             |                |             |                      |             |                   |      |                              |      |   |
| <b>C.Typ</b>        | <b>SMARTCARD trip: SMARTCARD parameter set not compatible with drive</b>  |           |          |      |                       |                     |                |      |                              |             |                     |             |                     |             |                    |             |                   |      |                     |             |                |             |                      |             |                   |      |                              |      |   |
| 187                 | Press the red  reset button<br>Ensure destination drive type is the same as the source parameter file drive type   |           |          |      |                       |                     |                |      |                              |             |                     |             |                     |             |                    |             |                   |      |                     |             |                |             |                      |             |                   |      |                              |      |   |

**Table 9-5 SMARTCARD status indications**

| Lower display | Description   | Lower display | Description  |
|---------------|---|---------------|--|
| <b>boot</b>   | A parameter set is being transferred from the SMARTCARD to the drive during power-up. For further information, please refer to section 9.2.4 <i>Booting up from the SMARTCARD on every power up (Pr 11.42 = boot (4))</i> . | <b>cArd</b>   | The drive is writing a parameter set to the SMARTCARD during power-up. For further information, please refer to section 9.2.3 <i>Auto saving parameter changes (Pr 11.42 = Auto (3))</i> . |

## 10 Onboard PLC

### 10.1 Onboard PLC and SYPTLite

The Unidrive SP has the ability to store and execute a 4KB Onboard PLC ladder logic program without the need for additional hardware in the form of a Solutions Module.

The ladder logic program is written using SYPTLite, a Windows™ based ladder diagram editor allowing the development of programs for execution in Unidrive SP or SM-Applications Lite.

SYPTLite is designed to be easy to use and to make program development as simple as possible. The features provided are a sub-set of those in the SYPT program editor. SYPTLite programs are developed using ladder logic, a graphical language widely used to program PLCs (IEC61131-3). SYPTLite allows the user to "draw" a ladder diagram representing a program.

SYPTLite provides a complete environment for the development of ladder diagrams. Ladder diagrams can be created, compiled into user programs and downloaded to a Unidrive SP or SM-Applications Lite for execution, via the RJ45 serial communications port on the front of the drive. The run-time operation of the compiled ladder diagram on the target can also be monitored using SYPTLite and facilities are provided to interact with the program on the target by setting new values for target parameters.

SYPTLite is available on the CD which is supplied with the drive.

### 10.2 Benefits

The combination of the Onboard PLC and SYPTLite, means that Unidrive SP can replace nano and some micro PLCs in many applications. The Onboard PLC programs can consist of up to a maximum of 50 ladder logic rungs (up to 7 function blocks and 10 contacts per rung). The Onboard PLC program can also be transferred to and from a SMARTCARD for backup or quick commissioning

In addition to the basic ladder symbols, SYPTLite contains a sub-set of the function from the full version of SYPT. These include,

- Arithmetic blocks
- Comparison blocks
- Timers
- Counters
- Multiplexers
- Latches
- Bit manipulation

Typical applications for the Onboard PLC include,

- Ancillary pumps
- Fans and control valves
- Interlocking logic
- Sequences routines
- Custom control words.

### 10.3 Limitations

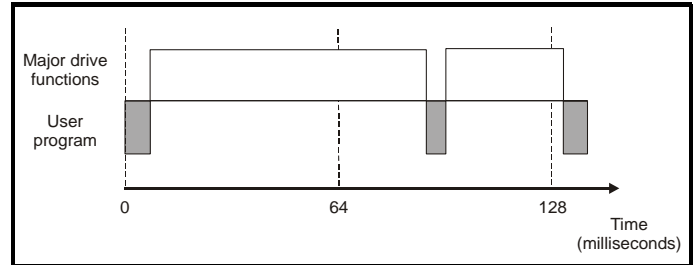
Compared with the SM-Applications or SM-Application Lite modules when programmed with SYPT, the Onboard PLC program has the following limitations:

- The maximum program size is 4032 bytes including header and optional source code.
- The Unidrive SP is rated for 100 program downloads. This limitation is imposed by the flash memory used to store the program within the drive.
- The user cannot create user variables. The user is only able to manipulate the drive parameter set.
- The program cannot be downloaded or monitored over CNet. The program is only accessible via the drives RJ45 serial communications port.
- There are no real-time tasks, i.e. the scheduling rate of the program cannot be guaranteed. SM-Applications tasks such as Clock, Event, Pos0 or Speed are not available. The Onboard PLC should not be

used for time-critical applications. For time-critical applications either the SM-Applications or SM-Applications Lite solutions modules should be used.

- The program runs at a low priority. The Unidrive SP provides a single background task in which to run a ladder diagram. The drive is prioritised to perform its major functions first, e.g. motor control, and will use any remaining processing time to execute the ladder diagram as a background activity. As the drive's processor becomes more heavily loaded, less time is spent executing the program.

**Figure 10-1 Unidrive SP Onboard PLC program scheduling**

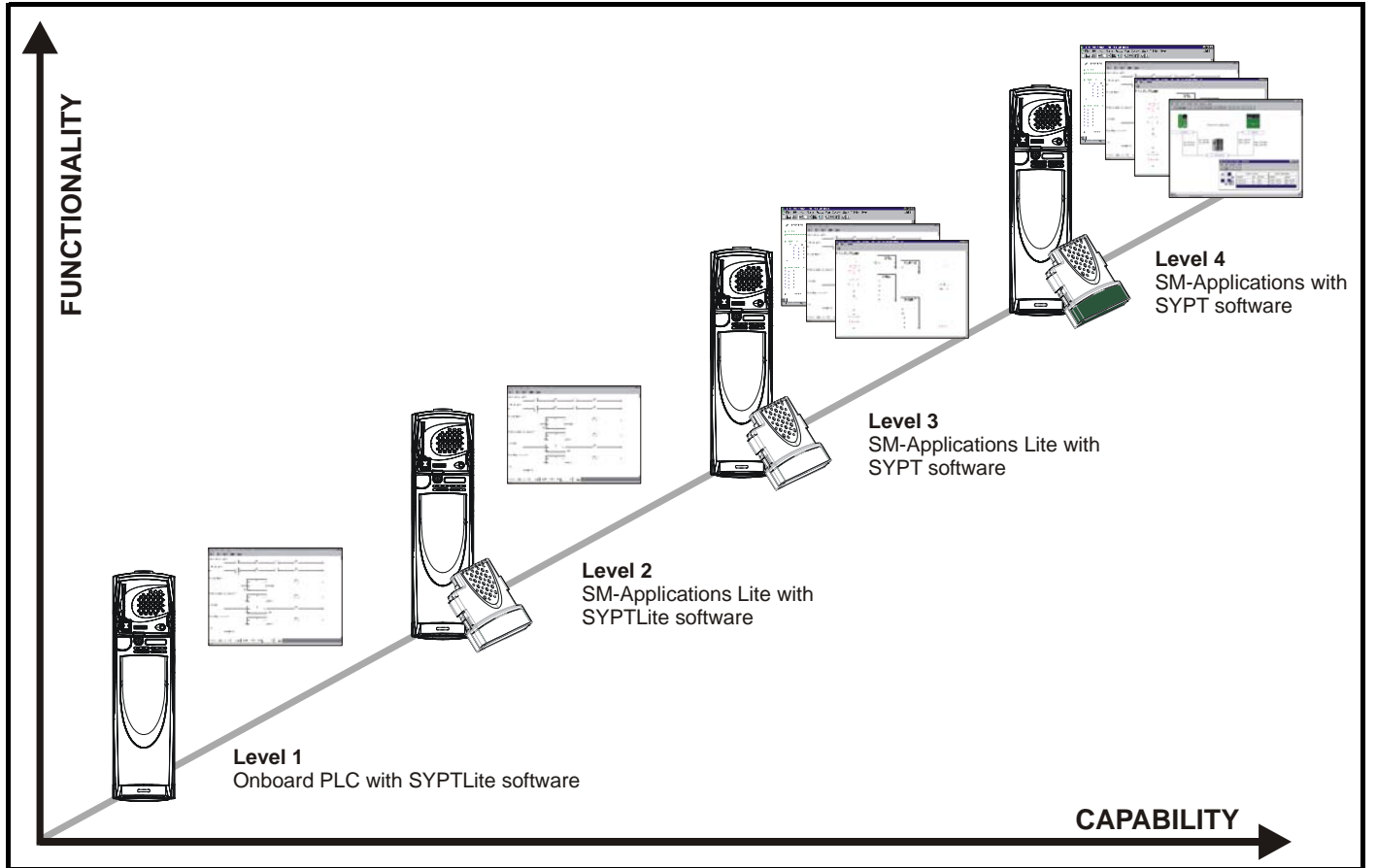


The user program is scheduled for a short period approximately once every 64ms. The time for which the program is scheduled will vary between 0.2ms and 2ms depending on the loading of the drive's processor.

When scheduled, several scans of the user program may be performed. Some scans may execute in microseconds. However, when the main drive functions are scheduled there will be a pause in the execution of the program causing some scans to take many milliseconds. SYPTLite displays the average execution time calculated over the last 10 scans of the user program.

The Onboard PLC and SYPTLite form the first level of functionality in a range of programmable options for Unidrive SP.

**Figure 10-2 Programming options for Unidrive SP**



SYPTLite can be used with either the Onboard PLC in the Unidrive SP or with SM-Applications Lite to create ladder logic programs.

SYPT can be used with either the SM-Applications Lite or SM-Applications to create fully flexible programs using ladder logic, function blocks or DPL script.

## 10.4 Getting started

SYPTLite can be found on the CD which is supplied with the drive.

### SYPTLite system requirements

- Windows 98/98SE/Me/NT4/2000/XP. **Windows 95 is not supported**
- Pentium III 500MHz or better recommended
- 128MB RAM
- Minimum of 800x600 screen resolution. 1024x768 is recommended
- Adobe Acrobat 5.10 or later (for viewing User Guides)
- Microsoft Internet Explorer V5.0 or later
- RS232 to RS485, RJ45 communications lead to connect the PC to a Unidrive SP
- Administrator rights under Windows NT/2000/XP are required to install the software

To install SYPTLite, insert the CD and the auto-run facility should start up the front-end screen, from which SYPTLite can be selected.

See the SYPTLite help file for more information regarding using SYPTLite, creating ladder diagrams and the available function blocks.

## 10.5 Onboard PLC parameters

The following parameters are associated with the Onboard PLC program.

| 11.47 |     | Drive Onboard PLC program enable |  |  |  |  |   |    |  |  |
|-------|-----|----------------------------------|--|--|--|--|---|----|--|--|
| RW    | Uni |                                  |  |  |  |  |   | US |  |  |
| ↕     |     | 0 to 2                           |  |  |  |  | ⇒ | 2  |  |  |

This parameter is used to start and stop the drive Onboard PLC program.

| Value | Description   |
|-------|---|
| 0     | Halt the drive Onboard PLC program.   |
| 1     | Run the drive Onboard PLC program (if fitted). Any out-of-range parameter writes attempted will be clipped to the maximum / minimum values valid for that parameter before being written. |
| 2     | Run the drive Onboard PLC program (if fitted). Any out-of-range parameter writes attempted will cause a 'UP ovr' trip.  |

| 11.48 |    | Drive Onboard PLC program status |  |  |  |  |    |    |  |  |
|-------|----|----------------------------------|--|--|--|--|----|----|--|--|
| RO    | Bi |                                  |  |  |  |  | NC | PT |  |  |
| ↕     |    | -128 to +127                     |  |  |  |  | ⇒  |    |  |  |

The drive Onboard PLC program status parameter indicates to the user the actual state of the drive Onboard PLC program.

| Value | Description   |
|-------|---|
| -n    | Onboard PLC program caused a drive trip due to an error condition while running rung n. Note that the rung number is shown on the display as a negative number. |
| 0     | Onboard PLC program is not fitted.  |
| 1     | Onboard PLC program is fitted but stopped.  |
| 2     | Onboard PLC program is fitted and running.  |

When an Onboard PLC program is fitted and running, the lower display of the drive flashes 'PLC' once every 10s.

| 11.49 |     | Drive Onboard PLC programming events |  |  |  |  |    |    |  |  |  |    |  |
|-------|-----|--------------------------------------|--|--|--|--|----|----|--|--|--|----|--|
| RO    | Uni |                                      |  |  |  |  | NC | PT |  |  |  | PS |  |
| ⇅     |     | 0 to 65,535                          |  |  |  |  | ⇒  |    |  |  |  |    |  |

The drive Onboard PLC programming events parameter holds the number of times an Onboard PLC program download has taken place and is 0 on dispatch from the factory. The Unidrive SP is rated for one hundred ladder program downloads. This parameter is not altered when defaults are loaded.

| 11.50 |     | Drive Onboard PLC program maximum scan time |  |  |  |  |    |    |  |  |  |  |  |
|-------|-----|---|--|--|--|--|----|----|--|--|--|--|--|
| RO    | Uni |   |  |  |  |  | NC | PT |  |  |  |  |  |
| ⇅     |     | 0 to 65,535 ms                              |  |  |  |  | ⇒  |    |  |  |  |  |  |

The Onboard PLC program maximum scan time parameter gives the longest scan time within the last ten scans of the drive Onboard PLC program. If the scan time is greater than the maximum value which can be represented by this parameter, the value will be clipped to the maximum value.

| 11.51 |     | Drive Onboard PLC program first run |  |  |  |  |    |    |  |  |  |  |  |
|-------|-----|-------------------------------------|--|--|--|--|----|----|--|--|--|--|--|
| RO    | Bit |                                     |  |  |  |  | NC | PT |  |  |  |  |  |
| ⇅     |     | OFF (0) or On (1)                   |  |  |  |  | ⇒  |    |  |  |  |  |  |

The Drive Onboard PLC program first run parameter is set for the duration of program scan from the stopped state. This enables the user to perform any required initialisation every time the program is run. This parameter is set every time the program is stopped.

## 10.6 Onboard PLC trips

The following trips are associated with the Onboard PLC program.

| Trip           | Diagnosis  |
|----------------|--|
| <b>UP ACC</b>  | <b>Onboard PLC program: Cannot access Onboard PLC program file on drive</b>  |
| <b>98</b>      | Disable drive - write access is not allowed when the drive is enabled.<br>Another source is already accessing Onboard PLC program - retry once the other action is complete. |
| <b>UP div0</b> | <b>Onboard PLC program attempted divide by zero</b>  |
| <b>90</b>      | Check program  |
| <b>UP OFL</b>  | <b>Onboard PLC program variables and function block calls using more than the allowed RAM space (stack overflow)</b>   |
| <b>95</b>      | Check program  |
| <b>UP ovr</b>  | <b>Onboard PLC program attempted out of range parameter write</b>  |
| <b>94</b>      | Check program  |
| <b>UP PAr</b>  | <b>Onboard PLC program attempted access to a non-existent parameter</b>  |
| <b>91</b>      | Check program  |
| <b>UP ro</b>   | <b>Onboard PLC program attempted write to a read-only parameter</b>  |
| <b>92</b>      | Check program  |
| <b>UP So</b>   | <b>Onboard PLC program attempted read of a write-only parameter</b>  |
| <b>93</b>      | Check program  |
| <b>UP udF</b>  | <b>Onboard PLC program undefined trip</b>  |
| <b>97</b>      | Check program  |
| <b>UP uSEr</b> | <b>Onboard PLC program requested a trip</b>  |
| <b>96</b>      | Check program  |

## 10.7 Onboard PLC and the SMARTCARD

The Onboard PLC program in a drive may be transferred from the drive to a SMARTCARD and vice versa.

- To transfer an Onboard PLC program from the drive to a SMARTCARD, set Pr **xx.00** to 5yyy and reset the drive
- To transfer an Onboard PLC program from the SMARTCARD to a drive, set Pr **xx.00** to 6yyy and reset the drive.


(Where yyy is the data block location, see Table 9-1 *SMARTCARD data blocks* on page 152 for restrictions on block numbers).

If an attempt is made to transfer an Onboard PLC program from a drive to the SMARTCARD when the drive contains no program, the block is still created on the SMARTCARD but it will contain no data. If this data block is then transferred to a drive, the destination drive will then have no Onboard PLC program.

The smallest SMARTCARD compatible with Unidrive SP has a capacity of 4064 bytes and each block can be up to 4064 bytes in size. The maximum size of a user program is 4032 bytes so it is guaranteed that any Onboard PLC program downloaded to a Unidrive SP will fit on to an empty SMARTCARD. A SMARTCARD can contain a number of Onboard PLC programs until the capacity of the card is used.

# 11 Advanced parameters

This is a quick reference to all parameters in the drive showing units, ranges limits etc, with block diagrams to illustrate their function. Full descriptions of the parameters can be found in the *Unidrive SP Advanced User Guide* on the supplied CD ROM.

|  |  |
|--|--|
| <br><b>WARNING</b> | <p>These advanced parameters are listed for reference purposes only. The lists in this chapter do not include sufficient information for adjusting these parameters. Incorrect adjustment can affect the safety of the system, and damage the drive and or external equipment. Before attempting to adjust any of these parameters, refer to the <i>Unidrive SP Advanced User Guide</i>.</p> |
|--|--|

**Table 11-1 Menu descriptions**

| Menu number | Description  |
|-------------|--|
| 0           | Commonly used basic set up parameters for quick / easy programming |
| 1           | Frequency / speed reference  |
| 2           | Ramps  |
| 3           | Frequency slaving, speed feedback and speed control                |
| 4           | Torque and current control   |
| 5           | Motor control  |
| 6           | Sequencer and clock  |
| 7           | Analogue I/O   |
| 8           | Digital I/O  |
| 9           | Programmable logic, motorised pot and binary sum                   |
| 10          | Status and trips   |
| 11          | General drive set-up   |
| 12          | Threshold detectors and variable selectors                         |
| 13          | Position control   |
| 14          | User PID controller  |
| 15, 16, 17  | Solutions Module slots   |
| 18          | Application menu 1   |
| 19          | Application menu 2   |
| 20          | Application menu 3   |
| 21          | Second motor parameters  |
| 22          | Additional Menu 0 set-up   |

**Operation mode abbreviations:**

- OL> Open loop
- CL> Closed loop (which incorporates closed loop vector and servo mode)
- VT> Closed loop vector mode
- SV> Servo

**Default abbreviations:**

- EUR> European default value
- USA> USA default value

**NOTE**

Parameter numbers shown in brackets {...} are the equivalent Menu 0 parameters. Some Menu 0 parameters appear twice since their function depends on the operating mode.

The Range - CL column applies to both Closed-loop Vector and Closed-loop Servo. For some parameters, this column applies only to one of these modes; this is indicated accordingly in the Default columns.

In some cases, the function or range of a parameter is affected by the setting of another parameter; the information in the lists relates to the default condition of such parameters.

**Table 11-2 Key to parameter table coding**

| Coding | Attribute  |
|--------|--|
| RW     | Read/write: can be written by the user   |
| RO     | Read only: can only be read by the user  |
| Bit    | 1 bit parameter. 'On' or 'OFF' on the display  |
| Bi     | Bipolar parameter  |
| Uni    | Unipolar parameter   |
| Txt    | Text: the parameter uses text strings instead of numbers.  |
| FI     | Filtered: some parameters which can have rapidly changing values are filtered when displayed on the drive keypad for easy viewing.   |
| DE     | Destination: This parameter selects the destination of an input or logic function.   |
| RA     | Rating dependant: this parameter is likely to have different values and ranges with drives of different voltage and current ratings. This parameters is not transferred by SMARTCARDS when the rating of the destination drive is different from the source drive. |
| NC     | Not cloned: not transferred to or from SMARTCARDS during cloning.  |
| PT     | Protected: cannot be used as a destination.  |
| US     | User save: parameter saved in drive EEPROM when the user initiates a parameter save.   |
| PS     | Power-down save: parameter automatically saved in drive EEPROM when the under volts (UV) trip occurs. With software version V01.08.00 and later, power-down save parameters are also saved in the drive when the user initiates a parameter save.                  |

**Table 11-3 Feature look-up table**

| Feature                    | Parameter number (Pr) |                |         |       |              |       |      |       |                |       |       |       |       |
|----------------------------|-----------------------|----------------|---------|-------|--------------|-------|------|-------|----------------|-------|-------|-------|-------|
|                            | 2.10                  | 2.11 to 2.19   | 2.32    | 2.33  | 2.34         | 2.02  |      |       |                |       |       |       |       |
| Acceleration rates         | 2.10                  | 2.11 to 2.19   | 2.32    | 2.33  | 2.34         | 2.02  |      |       |                |       |       |       |       |
| Analog speed reference 1   | 1.36                  | 7.1            | 7.01    | 7.07  | 7.08         | 7.09  | 7.25 | 7.26  | 7.30           |       |       |       |       |
| Analog speed reference 2   | 1.37                  | 7.14           | 1.41    | 7.02  | 7.11         | 7.12  | 7.13 | 7.28  | 7.31           |       |       |       |       |
| Analog I/O                 | Menu 7                |                |         |       |              |       |      |       |                |       |       |       |       |
| Analog input 1             | 7.01                  | 7.07           | 7.08    | 7.09  | 7.1          | 7.25  | 7.26 | 7.30  |                |       |       |       |       |
| Analog input 2             | 7.02                  | 7.11           | 7.12    | 7.13  | 7.14         | 7.28  | 7.31 |       |                |       |       |       |       |
| Analog input 3             | 7.03                  | 7.15           | 7.16    | 7.17  | 7.18         | 7.29  | 7.32 |       |                |       |       |       |       |
| Analog output 1            | 7.19                  | 7.20           | 7.21    | 7.33  |              |       |      |       |                |       |       |       |       |
| Analog output 2            | 7.22                  | 7.23           | 7.24    |       |              |       |      |       |                |       |       |       |       |
| Application menu           | Menu 18               |                | Menu 19 |       | Menu 20      |       |      |       |                |       |       |       |       |
| At speed indicator bit     | 3.06                  | 3.07           | 3.09    | 10.06 | 10.05        | 10.07 |      |       |                |       |       |       |       |
| Auto reset                 | 10.34                 | 10.35          | 10.36   | 10.01 |              |       |      |       |                |       |       |       |       |
| Autotune                   | 5.12                  | 5.16           | 5.17    | 5.23  | 5.24         | 5.25  | 5.10 | 5.29  | 5.30           |       |       |       |       |
| Binary sum                 | 9.29                  | 9.30           | 9.31    | 9.32  | 9.33         | 9.34  |      |       |                |       |       |       |       |
| Bipolar speed              | 1.10                  |                |         |       |              |       |      |       |                |       |       |       |       |
| Brake control              | 12.40 to 12.49        |                |         |       |              |       |      |       |                |       |       |       |       |
| Braking                    | 10.11                 | 10.10          | 10.30   | 10.31 | 6.01         | 2.04  | 2.02 | 10.12 | 10.39          | 10.40 |       |       |       |
| Catch a spinning motor     | 6.09                  |                |         |       |              |       |      |       |                |       |       |       |       |
| Cloning                    | 11.42                 | 11.36 to 11.40 |         |       |              |       |      |       |                |       |       |       |       |
| Coast to stop              | 6.01                  |                |         |       |              |       |      |       |                |       |       |       |       |
| Comms                      | 11.23 to 11.26        |                |         |       |              |       |      |       |                |       |       |       |       |
| Cost - per kWh electricity | 6.16                  | 6.17           | 6.24    | 6.25  | 6.26         | 6.40  |      |       |                |       |       |       |       |
| Current controller         | 4.13                  | 4.14           |         |       |              |       |      |       |                |       |       |       |       |
| Current feedback           | 4.01                  | 4.02           | 4.17    | 4.04  | 4.12         | 4.20  | 4.23 | 4.24  | 4.26           | 10.08 | 10.09 | 10.17 |       |
| Current limits             | 4.05                  | 4.06           | 4.07    | 4.18  | 4.15         | 4.19  | 4.16 | 5.07  | 5.10           | 10.08 | 10.09 | 10.17 |       |
| DC bus voltage             | 5.05                  | 2.08           |         |       |              |       |      |       |                |       |       |       |       |
| DC injection braking       | 6.06                  | 6.07           | 6.01    |       |              |       |      |       |                |       |       |       |       |
| Deceleration rates         | 2.20                  | 2.21 to 2.29   |         | 2.04  | 2.35 to 2.37 |       | 2.02 | 2.04  | 2.08           | 6.01  | 10.30 | 10.31 | 10.39 |
| Defaults                   | 11.43                 | 11.46          |         |       |              |       |      |       |                |       |       |       |       |
| Digital I/O                | Menu 8                |                |         |       |              |       |      |       |                |       |       |       |       |
| Digital I/O read word      | 8.20                  |                |         |       |              |       |      |       |                |       |       |       |       |
| Digital I/O T24            | 8.01                  | 8.11           | 8.21    | 8.31  |              |       |      |       |                |       |       |       |       |
| Digital I/O T25            | 8.02                  | 8.12           | 8.22    | 8.32  |              |       |      |       |                |       |       |       |       |
| Digital I/O T26            | 8.03                  | 8.13           | 8.23    | 8.33  |              |       |      |       |                |       |       |       |       |
| Digital input T27          | 8.04                  | 8.14           | 8.24    |       |              |       |      |       |                |       |       |       |       |
| Digital input T28          | 8.05                  | 8.15           | 8.25    | 8.39  |              |       |      |       |                |       |       |       |       |
| Digital input T29          | 8.06                  | 8.16           | 8.26    | 8.39  |              |       |      |       |                |       |       |       |       |
| Digital lock               | 13.10                 | 13.01 to 13.09 |         | 13.11 | 13.12        | 13.16 | 3.22 | 3.23  | 13.19 to 13.23 |       |       |       |       |
| Digital output T22         | 8.08                  | 8.18           | 8.28    |       |              |       |      |       |                |       |       |       |       |
| Direction                  | 10.13                 | 6.30           | 6.31    | 1.03  | 10.14        | 2.01  | 3.02 | 8.03  | 8.04           | 10.40 |       |       |       |
| Display timeout            | 11.41                 |                |         |       |              |       |      |       |                |       |       |       |       |
| Drive active               | 10.02                 | 10.40          |         |       |              |       |      |       |                |       |       |       |       |
| Drive derivative           | 11.28                 |                |         |       |              |       |      |       |                |       |       |       |       |
| Drive healthy              | 10.01                 | 8.27           | 8.07    | 8.17  | 10.36        | 10.40 |      |       |                |       |       |       |       |
| Dynamic performance        | 5.26                  |                |         |       |              |       |      |       |                |       |       |       |       |
| Dynamic V/F                | 5.13                  |                |         |       |              |       |      |       |                |       |       |       |       |
| Electronic nameplate       | 3.49                  |                |         |       |              |       |      |       |                |       |       |       |       |
| Enable                     | 6.15                  | 8.09           | 8.10    |       |              |       |      |       |                |       |       |       |       |
| Encoder less CLV mode      | 3.24                  |                |         |       |              |       |      |       |                |       |       |       |       |

| Feature                                | Parameter number (Pr) |                |         |      |      |      |              |      |      |  |  |  |  |
|--|-----------------------|----------------|---------|------|------|------|--------------|------|------|--|--|--|--|
| Encoder reference                      | 3.43                  | 3.44           | 3.45    | 3.46 |      |      |              |      |      |  |  |  |  |
| Encoder set up                         | 3.33                  | 3.34 to 3.42   |         | 3.47 | 3.48 |      |              |      |      |  |  |  |  |
| External trip                          | 10.32                 | 8.10           | 8.07    |      |      |      |              |      |      |  |  |  |  |
| Fan speed                              | 6.45                  |                |         |      |      |      |              |      |      |  |  |  |  |
| Field weakening - induction motor      | 5.29                  | 5.30           | 1.06    | 5.28 |      |      |              |      |      |  |  |  |  |
| Field weakening - servo                | 5.22                  | 1.06           |         |      |      |      |              |      |      |  |  |  |  |
| Filter change                          | 6.19                  | 6.18           |         |      |      |      |              |      |      |  |  |  |  |
| Frequency reference selection          | 1.14                  | 1.15           |         |      |      |      |              |      |      |  |  |  |  |
| Frequency slaving                      | 3.01                  | 3.13           | 3.14    | 3.15 | 3.16 | 3.17 | 3.18         |      |      |  |  |  |  |
| Hard speed reference                   | 3.22                  | 3.23           |         |      |      |      |              |      |      |  |  |  |  |
| Heavy duty rating                      | 5.07                  | 11.32          |         |      |      |      |              |      |      |  |  |  |  |
| High stability space vector modulation | 5.19                  |                |         |      |      |      |              |      |      |  |  |  |  |
| I/O sequencer                          | 6.04                  | 6.30           | 6.31    | 6.32 | 6.33 | 6.34 | 6.42         | 6.43 | 6.41 |  |  |  |  |
| Inertia compensation                   | 2.38                  | 5.12           | 4.22    | 3.18 |      |      |              |      |      |  |  |  |  |
| Jog reference                          | 1.05                  | 2.19           | 2.29    |      |      |      |              |      |      |  |  |  |  |
| Ke                                     | 5.33                  |                |         |      |      |      |              |      |      |  |  |  |  |
| Keypad reference                       | 1.17                  | 1.14           | 1.43    | 1.51 | 6.12 | 6.13 |              |      |      |  |  |  |  |
| Kt                                     | 5.32                  |                |         |      |      |      |              |      |      |  |  |  |  |
| Limit switches                         | 6.35                  | 6.36           |         |      |      |      |              |      |      |  |  |  |  |
| Local position reference               | 13.20 to 13.23        |                |         |      |      |      |              |      |      |  |  |  |  |
| Logic function 1                       | 9.01                  | 9.04           | 9.05    | 9.06 | 9.07 | 9.08 | 9.09         | 9.10 |      |  |  |  |  |
| Logic function 2                       | 9.02                  | 9.14           | 9.15    | 9.16 | 9.17 | 9.18 | 9.19         | 9.20 |      |  |  |  |  |
| Low voltage supply                     | 6.44                  | 6.46           |         |      |      |      |              |      |      |  |  |  |  |
| Mains loss                             | 6.03                  | 10.15          | 10.16   | 5.05 |      |      |              |      |      |  |  |  |  |
| Marker pulse                           | 3.32                  | 3.31           |         |      |      |      |              |      |      |  |  |  |  |
| Maximum speed                          | 1.06                  |                |         |      |      |      |              |      |      |  |  |  |  |
| Menu 0 set up                          | 11.01 to 11.22        |                | Menu 22 |      |      |      |              |      |      |  |  |  |  |
| Minimum speed                          | 1.07                  | 10.04          |         |      |      |      |              |      |      |  |  |  |  |
| Modules - number of                    | 11.35                 |                |         |      |      |      |              |      |      |  |  |  |  |
| Motor map                              | 5.06                  | 5.07           | 5.08    | 5.09 | 5.10 | 5.11 |              |      |      |  |  |  |  |
| Motor map 2                            | Menu 21               |                | 11.45   |      |      |      |              |      |      |  |  |  |  |
| Motorised potentiometer                | 9.21                  | 9.22           | 9.23    | 9.24 | 9.25 | 9.26 | 9.27         | 9.28 |      |  |  |  |  |
| Offset speed reference                 | 1.04                  | 1.38           | 1.09    |      |      |      |              |      |      |  |  |  |  |
| Onboard PLC                            | 11.47 to 11.51        |                |         |      |      |      |              |      |      |  |  |  |  |
| Open collector digital outputs         | 8.30                  |                |         |      |      |      |              |      |      |  |  |  |  |
| Open loop vector mode                  | 5.14                  | 5.17           | 5.23    |      |      |      |              |      |      |  |  |  |  |
| Operating mode                         | 0.48                  | 3.24           | 5.14    |      |      |      |              |      |      |  |  |  |  |
| Operating mode                         | 11.31                 |                |         |      |      |      |              |      |      |  |  |  |  |
| Orientation                            | 13.10                 | 13.13 to 13.15 |         |      |      |      |              |      |      |  |  |  |  |
| Output                                 | 5.01                  | 5.02           | 5.03    | 5.04 |      |      |              |      |      |  |  |  |  |
| Overspeed threshold                    | 3.08                  |                |         |      |      |      |              |      |      |  |  |  |  |
| Phase angle                            | 3.25                  | 5.12           |         |      |      |      |              |      |      |  |  |  |  |
| PID controller                         | Menu 14               |                |         |      |      |      |              |      |      |  |  |  |  |
| Position feedback - drive              | 3.28                  | 3.29           | 3.30    | 3.50 |      |      |              |      |      |  |  |  |  |
| Positive logic                         | 8.29                  |                |         |      |      |      |              |      |      |  |  |  |  |
| Power up parameter                     | 11.22                 | 11.21          |         |      |      |      |              |      |      |  |  |  |  |
| Precision reference                    | 1.18                  | 1.19           | 1.20    | 1.44 |      |      |              |      |      |  |  |  |  |
| Preset speeds                          | 1.15                  | 1.21 to 1.28   |         | 1.16 | 1.14 | 1.42 | 1.45 to 1.48 |      | 1.50 |  |  |  |  |
| Programmable logic                     | Menu 9                |                |         |      |      |      |              |      |      |  |  |  |  |

| Feature                    | Parameter number (Pr) |                |                |       |       |       |       |       |       |       |  |  |  |
|----------------------------|-----------------------|----------------|----------------|-------|-------|-------|-------|-------|-------|-------|--|--|--|
| Quasi square operation     | 5.20                  |                |                |       |       |       |       |       |       |       |  |  |  |
| Ramp (accel / decel) mode  | 2.04                  | 2.08           | 6.01           | 2.02  | 2.03  | 10.30 | 10.31 | 10.39 |       |       |  |  |  |
| Rated speed autotune       | 5.16                  | 5.08           |                |       |       |       |       |       |       |       |  |  |  |
| Regenerating               | 10.10                 | 10.11          | 10.30          | 10.31 | 6.01  | 2.04  | 2.02  | 10.12 | 10.39 | 10.40 |  |  |  |
| Relative jog               | 13.17 to 13.19        |                |                |       |       |       |       |       |       |       |  |  |  |
| Relay output               | 8.07                  | 8.17           | 8.27           |       |       |       |       |       |       |       |  |  |  |
| Reset                      | 10.33                 | 8.02           | 8.22           | 10.34 | 10.35 | 10.36 | 10.01 |       |       |       |  |  |  |
| S ramp                     | 2.06                  | 2.07           |                |       |       |       |       |       |       |       |  |  |  |
| Sample rates               | 5.18                  |                |                |       |       |       |       |       |       |       |  |  |  |
| Secure disable input       | 8.09                  | 8.10           |                |       |       |       |       |       |       |       |  |  |  |
| Security code              | 11.3                  | 11.44          |                |       |       |       |       |       |       |       |  |  |  |
| Serial comms               | 11.23 to 11.26        |                |                |       |       |       |       |       |       |       |  |  |  |
| Skip speeds                | 1.29                  | 1.30           | 1.31           | 1.32  | 1.33  | 1.34  | 1.35  |       |       |       |  |  |  |
| Slip compensation          | 5.27                  | 5.08           |                |       |       |       |       |       |       |       |  |  |  |
| Smartcard                  | 11.36 to 11.40        |                | 11.42          |       |       |       |       |       |       |       |  |  |  |
| Software version           | 11.29                 | 11.34          |                |       |       |       |       |       |       |       |  |  |  |
| Speed controller           | 3.10 to 3.17          |                | 3.19           | 3.20  | 3.21  |       |       |       |       |       |  |  |  |
| Speed feedback             | 3.02                  | 3.03           | 3.04           |       |       |       |       |       |       |       |  |  |  |
| Speed feedback - drive     | 3.26                  | 3.27           | 3.28           | 3.29  | 3.30  | 3.31  | 3.42  |       |       |       |  |  |  |
| Speed reference selection  | 1.14                  | 1.15           | 1.49           | 1.50  | 1.01  |       |       |       |       |       |  |  |  |
| Status word                | 10.40                 |                |                |       |       |       |       |       |       |       |  |  |  |
| Supply                     | 6.44                  | 5.05           | 6.46           |       |       |       |       |       |       |       |  |  |  |
| Switching frequency        | 5.18                  | 5.35           | 7.34           | 7.35  |       |       |       |       |       |       |  |  |  |
| Thermal protection - drive | 5.18                  | 5.35           | 7.04           | 7.05  | 7.06  | 7.32  | 7.35  | 10.18 |       |       |  |  |  |
| Thermal protection - motor | 4.15                  | 5.07           | 4.19           | 4.16  | 4.25  | 7.15  |       |       |       |       |  |  |  |
| Thermistor input           | 7.15                  | 7.03           |                |       |       |       |       |       |       |       |  |  |  |
| Threshold detector 1       | 12.01                 | 12.03 to 12.07 |                |       |       |       |       |       |       |       |  |  |  |
| Threshold detector 2       | 12.02                 | 12.23 to 12.27 |                |       |       |       |       |       |       |       |  |  |  |
| Time - filter change       | 6.19                  | 6.18           |                |       |       |       |       |       |       |       |  |  |  |
| Time - powered up log      | 6.20                  | 6.21           | 6.28           |       |       |       |       |       |       |       |  |  |  |
| Time - run log             | 6.22                  | 6.23           | 6.28           |       |       |       |       |       |       |       |  |  |  |
| Torque                     | 4.03                  | 4.26           | 5.32           |       |       |       |       |       |       |       |  |  |  |
| Torque mode                | 4.08                  | 4.11           | 4.09           | 4.10  |       |       |       |       |       |       |  |  |  |
| Trip detection             | 10.37                 | 10.38          | 10.20 to 10.29 |       |       |       |       |       |       |       |  |  |  |
| Trip log                   | 10.20 to 10.29        |                | 6.28           |       |       |       |       |       |       |       |  |  |  |
| Trip log                   | 10.20 to 10.29        |                | 10.41 to 10.51 |       | 6.28  |       |       |       |       |       |  |  |  |
| Under voltage              | 5.05                  | 10.16          | 10.15          |       |       |       |       |       |       |       |  |  |  |
| V/F mode                   | 5.15                  | 5.14           |                |       |       |       |       |       |       |       |  |  |  |
| Variable selector 1        | 12.08 to 12.15        |                |                |       |       |       |       |       |       |       |  |  |  |
| Variable selector 2        | 12.28 to 12.35        |                |                |       |       |       |       |       |       |       |  |  |  |
| Velocity feed forward      | 1.39                  | 1.40           |                |       |       |       |       |       |       |       |  |  |  |
| Voltage controller         | 5.31                  |                |                |       |       |       |       |       |       |       |  |  |  |
| Voltage mode               | 5.14                  | 5.17           | 5.23           | 5.15  |       |       |       |       |       |       |  |  |  |
| Voltage rating             | 11.33                 | 5.09           | 5.05           |       |       |       |       |       |       |       |  |  |  |
| Voltage supply             | 6.44                  | 6.46           | 5.05           |       |       |       |       |       |       |       |  |  |  |
| Warning                    | 10.19                 | 10.12          | 10.17          | 10.18 | 10.40 |       |       |       |       |       |  |  |  |
| Zero speed indicator bit   | 3.05                  | 10.03          |                |       |       |       |       |       |       |       |  |  |  |

### Parameter ranges and variable maximums:

The two values provided define the minimum and maximum values for the given parameter. In some cases the parameter range is variable and dependant on either:

- other parameters
- the drive rating
- drive mode
- or a combination of these

The values given in Table 11-4 are the variable maximums used in the drive.

**Table 11-4 Definition of parameter ranges & variable maximums**

| Maximum   | Definition  |
|---|---|
| SPEED_FREQ_MAX<br>[Open-loop 3000.0Hz,<br>Closed-loop vector and Servo<br>40000.0rpm] | <b>Maximum speed (closed-loop mode) reference or frequency (open-loop mode) reference</b><br>If Pr 1.08 = 0: SPEED_FREQ_MAX = Pr 1.06<br>If Pr 1.08 = 1: SPEED_FREQ_MAX is Pr 1.06 or – Pr 1.07 whichever is the largest<br>(If the second motor map is selected Pr 21.01 is used instead of Pr 1.06 and Pr 21.02 instead of Pr 1.07)   |
| SPEED_LIMIT_MAX<br>[40000.0rpm]   | <b>Maximum applied to speed reference limits</b><br>A maximum limit may be applied to the speed reference to prevent the nominal encoder frequency from exceeding 500kHz (410kHz for software version V01.06.00 and earlier). The maximum is defined by<br>SPEED_LIMIT_MAX (in rpm) = 500kHz x 60 / ELPR = 3.0 x 10 <sup>7</sup> / ELPR subject to an absolute maximum of 40,000 rpm.<br>ELPR is equivalent encoder lines per revolution and is the number of lines that would be produced by a quadrature encoder.<br>Quadrature encoder ELPR = number of lines per revolution<br>F and D encoder ELPR = number of lines per revolution / 2<br>Resolver ELPR = resolution / 4<br>SINCOS encoder ELPR = number of sine waves per revolution<br>Serial comms encoder ELPR = resolution / 4<br>This maximum is defined by the device selected with the speed feedback selector (Pr 3.26) and the ELPR set for the position feedback device. |
| SPEED_MAX<br>[40000.0rpm]   | <b>Maximum speed</b><br>This maximum is used for some speed related parameters in menu 3. To allow headroom for overshoot etc. the maximum speed is twice the maximum speed reference.<br>SPEED_MAX = 2 x SPEED_FREQ_MAX  |
| RATED_CURRENT_MAX<br>[9999.99A]   | <b>Maximum motor rated current</b><br>RATED_CURRENT_MAX = 1.36 x K <sub>C</sub> .<br>The motor rated current can be increased above K <sub>C</sub> up to a level not exceeding 1.36 x K <sub>C</sub> . (Maximum motor rated current is the maximum normal duty current rating.)<br>The actual level varies from one drive size to another, refer to Table 11-5.   |
| DRIVE_CURRENT_MAX<br>[9999.99A]   | <b>Maximum drive current</b><br>The maximum drive current is the current at the over current trip level and is given by:<br>DRIVE_CURRENT_MAX = K <sub>C</sub> / 0.45   |

| Maximum                               | Definition   |
|---------------------------------------|--|
| MOTOR1_CURRENT_LIMIT_MAX<br>[1000.0%] | <p><b>Maximum current limit settings for motor map 1</b><br/>This maximum current limit setting is the maximum applied to the current limit parameters in motor map 1.</p> <p><b>Open Loop</b></p> $\text{Maximum current limit} = \frac{\sqrt{\left[\left[\frac{\text{Maximum current}}{\text{Motor rated current}}\right]^2 + \text{PF}^2 - 1\right]}}{\text{PF}} \times 100\%$ <p>Where:<br/>The Maximum current is either (1.5 x K<sub>C</sub>) when the motor rated current set in Pr <b>5.07</b> is less than or equal to the maximum Heavy Duty current rating given by Pr <b>11.32</b>, otherwise it is (1.1 x Normal Duty rating).<br/>Motor rated current is given by Pr <b>5.07</b><br/>PF is motor rated power factor given by Pr <b>5.10</b></p> <p><b>Closed Loop Vector</b></p> $\text{Maximum current limit} = \frac{\sqrt{\left[\left[\frac{\text{Maximum current}}{\text{Motor rated current}}\right]^2 + \cos(\varphi_1)^2 - 1\right]}}{\cos(\varphi_1)} \times 100\%$ <p>Where:<br/>The Maximum current is either (1.75 x K<sub>C</sub>) when the motor rated current set in Pr <b>5.07</b> is less than or equal to the maximum Heavy Duty current rating given by Pr <b>11.32</b>, otherwise it is (1.1 x Normal Duty rating).<br/>Motor rated current is given by Pr <b>5.07</b><br/>φ<sub>1</sub> = cos<sup>-1</sup>(PF) - φ<sub>2</sub>. This is measured by the drive during an autotune. See Menu 4 in the <i>Unidrive SP Advanced User Guide</i> for more information regarding φ<sub>2</sub>.<br/>PF is motor rated power factor given by Pr <b>5.10</b></p> <p><b>Servo</b></p> $\text{Maximum current limit} = \left[\frac{\text{Maximum current}}{\text{Motor rated current}}\right] \times 100\%$ <p>Where:<br/>The Maximum current is either (1.75 x K<sub>C</sub>) when the motor rated current set in Pr <b>5.07</b> is less than or equal to the maximum Heavy Duty current rating given by Pr <b>11.32</b>, otherwise it is (1.1 x Normal Duty rating).<br/>Motor rated current is given by Pr <b>5.07</b></p> |
| MOTOR2_CURRENT_LIMIT_MAX<br>[1000.0%] | <p><b>Maximum current limit settings for motor map 2</b><br/>This maximum current limit setting is the maximum applied to the current limit parameters in motor map 2.<br/>The formulae for MOTOR2_CURRENT_LIMIT_MAX are the same for MOTOR1_CURRENT_LIMIT_MAX except that Pr <b>5.07</b> is replaced with Pr <b>21.07</b> and Pr <b>5.10</b> is replaced with Pr <b>21.10</b>.</p>  |
| TORQUE_PROD_CURRENT_MAX<br>[1000.0%]  | <p><b>Maximum torque producing current</b><br/>This is used as a maximum for torque and torque producing current parameters. It is MOTOR1_CURRENT_LIMIT_MAX or MOTOR2_CURRENT_LIMIT_MAX depending on which motor map is currently active.</p>  |
| USER_CURRENT_MAX<br>[1000.0%]         | <p><b>Current parameter limit selected by the user</b><br/>The user can select a maximum for Pr <b>4.08</b> (torque reference) and Pr <b>4.20</b> (percentage load) to give suitable scaling for analogue I/O with Pr <b>4.24</b>. This maximum is subject to a limit of MOTOR1_CURRENT_LIMIT_MAX or MOTOR2_CURRENT_LIMIT_MAX depending on which motor map is currently active.<br/>USER_CURRENT_MAX = Pr <b>4.24</b></p>  |
| AC_VOLTAGE_SET_MAX<br>[690V]          | <p><b>Maximum output voltage set-point</b><br/>Defines the maximum motor voltage that can be selected.<br/>200V drives: 240V, 400V drives: 480V<br/>575V drives: 575V, 690V drives: 690V</p>   |
| AC_VOLTAGE_MAX<br>[930V]              | <p><b>Maximum AC output voltage</b><br/>This maximum has been chosen to allow for maximum AC voltage that can be produced by the drive including quasi-square wave operation as follows:<br/>AC_VOLTAGE_MAX = 0.78 x DC_VOLTAGE_MAX<br/>200V drives: 325V, 400V drives: 650V, 575V drives: 780V, 690V drives: 930V</p>   |
| DC_VOLTAGE_SET_MAX<br>[1150V]         | <p><b>Maximum DC voltage set-point</b><br/>200V rating drive: 0 to 400V, 400V rating drive: 0 to 800V<br/>575V rating drive: 0 to 955V, 690V rating drive: 0 to 1150V</p>  |
| DC_VOLTAGE_MAX<br>[1190V]             | <p><b>Maximum DC bus voltage</b><br/>The maximum measurable DC bus voltage.<br/>200V drives: 415V, 400V drives: 830V, 575V drives: 990V, 690V drives: 1190V</p>  |

| Maximum                  | Definition   |
|--------------------------|--|
| POWER_MAX<br>[9999.99kW] | <p><b>Maximum power in kW</b></p> <p>The maximum power has been chosen to allow for the maximum power that can be output by the drive with maximum AC output voltage, maximum controlled current and unity power factor. Therefore:</p> <p>Software V01.07.01 and earlier: <math>POWER\_MAX = \sqrt{3} \times AC\_VOLTAGE\_MAX \times RATED\_CURRENT \times 1.75</math></p> <p>Software V01.08.00 and later: <math>POWER\_MAX = \sqrt{3} \times AC\_VOLTAGE\_MAX \times DRIVE\_CURRENT\_MAX</math></p> |

The values given in square brackets indicate the absolute maximum value allowed for the variable maximum.

**Table 11-5 Maximum motor rated current for drives**

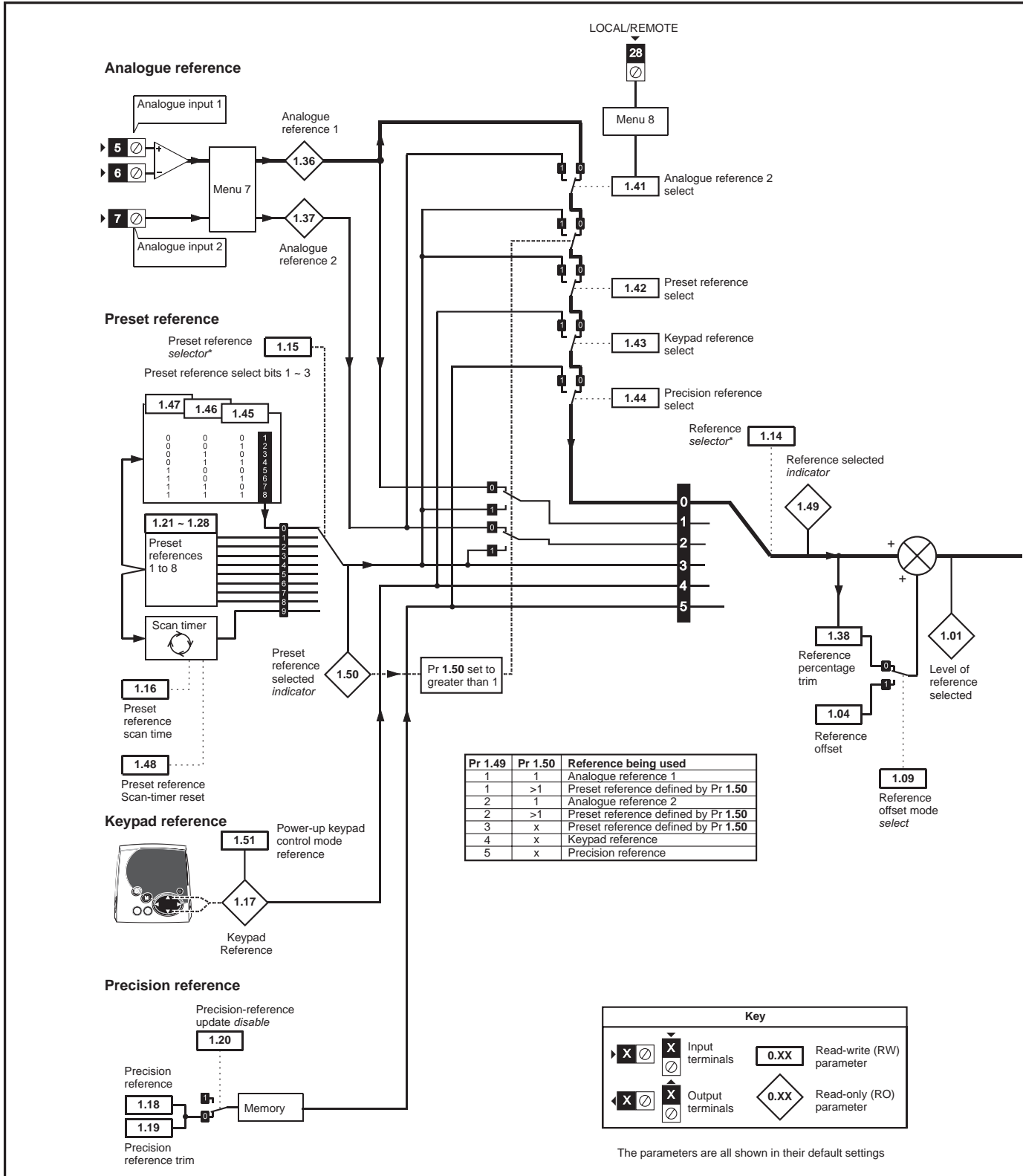
| Model  | K <sub>C</sub> | Maximum Heavy Duty current rating (Pr 11.32)<br>A | Maximum Normal Duty current rating<br>A |
|--------|----------------|---|---|
| SP1201 | 4.3            | 4.3   | 5.2                                     |
| SP1202 | 5.8            | 5.8   | 6.8                                     |
| SP1203 | 7.5            | 7.5   | 9.6                                     |
| SP1204 | 10.6           | 10.6  | 11                                      |
| SP2201 | 12.6           | 12.6  | 15.5                                    |
| SP2202 | 17.0           | 17.0  | 22.0                                    |
| SP2203 | 25.0           | 25.0  | 28.0                                    |
| SP3201 | 31.0           | 31.0  | 42.0                                    |
| SP3202 | 42.0           | 42.0  | 54.0                                    |
| SP4201 | 56.0           | 56.0  | 68.0                                    |
| SP4202 | 68.0           | 68.0  | 80.0                                    |
| SP4203 | 80.0           | 80.0  | 104.0                                   |
| SP1401 | 2.1            | 2.1   | 2.8                                     |
| SP1402 | 3.0            | 3.0   | 3.8                                     |
| SP1403 | 4.2            | 4.2   | 5.0                                     |
| SP1404 | 5.8            | 5.8   | 6.9                                     |
| SP1405 | 7.6            | 7.6   | 8.8                                     |
| SP1406 | 9.5            | 9.5   | 11.0                                    |
| SP2401 | 13.0           | 13.0  | 15.3                                    |
| SP2402 | 16.5           | 16.5  | 21.0                                    |
| SP2403 | 23.0           | 25.0  | 29.0                                    |
| SP2404 | 29.0           | 29.0  | 29.0                                    |
| SP3401 | 32.0           | 32.0  | 35.0                                    |
| SP3402 | 40.0           | 40.0  | 43.0                                    |
| SP3403 | 46.0           | 46.0  | 56.0                                    |
| SP4401 | 60.0           | 60.0  | 68.0                                    |
| SP4402 | 74.0           | 74.0  | 83.0                                    |
| SP4403 | 96.0           | 96.0  | 104.0                                   |
| SP5401 | 124.0          | 124.0   | 138.0                                   |
| SP5402 | 156.0          | 156.0   | 168.0                                   |
| SP6401 | 154.2          | 180.0   | 202.0                                   |
| SP6402 | 180.0          | 210.0   | 236.0                                   |
| SP3501 | 4.1            | 4.1   | 5.4                                     |
| SP3502 | 5.4            | 5.4   | 6.1                                     |
| SP3503 | 6.1            | 6.1   | 8.4                                     |
| SP3504 | 9.5            | 9.5   | 11.0                                    |
| SP3505 | 12.0           | 12.0  | 16.0                                    |
| SP3506 | 18.0           | 18.0  | 22.0                                    |
| SP3507 | 22.0           | 22.0  | 27.0                                    |
| SP4601 | 19.0           | 19.0  | 22.0                                    |
| SP4602 | 22.0           | 22.0  | 27.0                                    |
| SP4603 | 27.0           | 27.0  | 36.0                                    |
| SP4604 | 36.0           | 36.0  | 43.0                                    |
| SP4605 | 43.0           | 43.0  | 52.0                                    |
| SP4606 | 52.0           | 52.0  | 62.0                                    |
| SP5601 | 63.0           | 63.0  | 84.0                                    |
| SP5602 | 85.0           | 85.0  | 99.0                                    |
| SP6601 | 85.7           | 100.0   | 125.0                                   |
| SP6602 | 107.1          | 125.0   | 144.0                                   |

**Table 11-6 Maximum motor rated current for free standing cubicle drives**

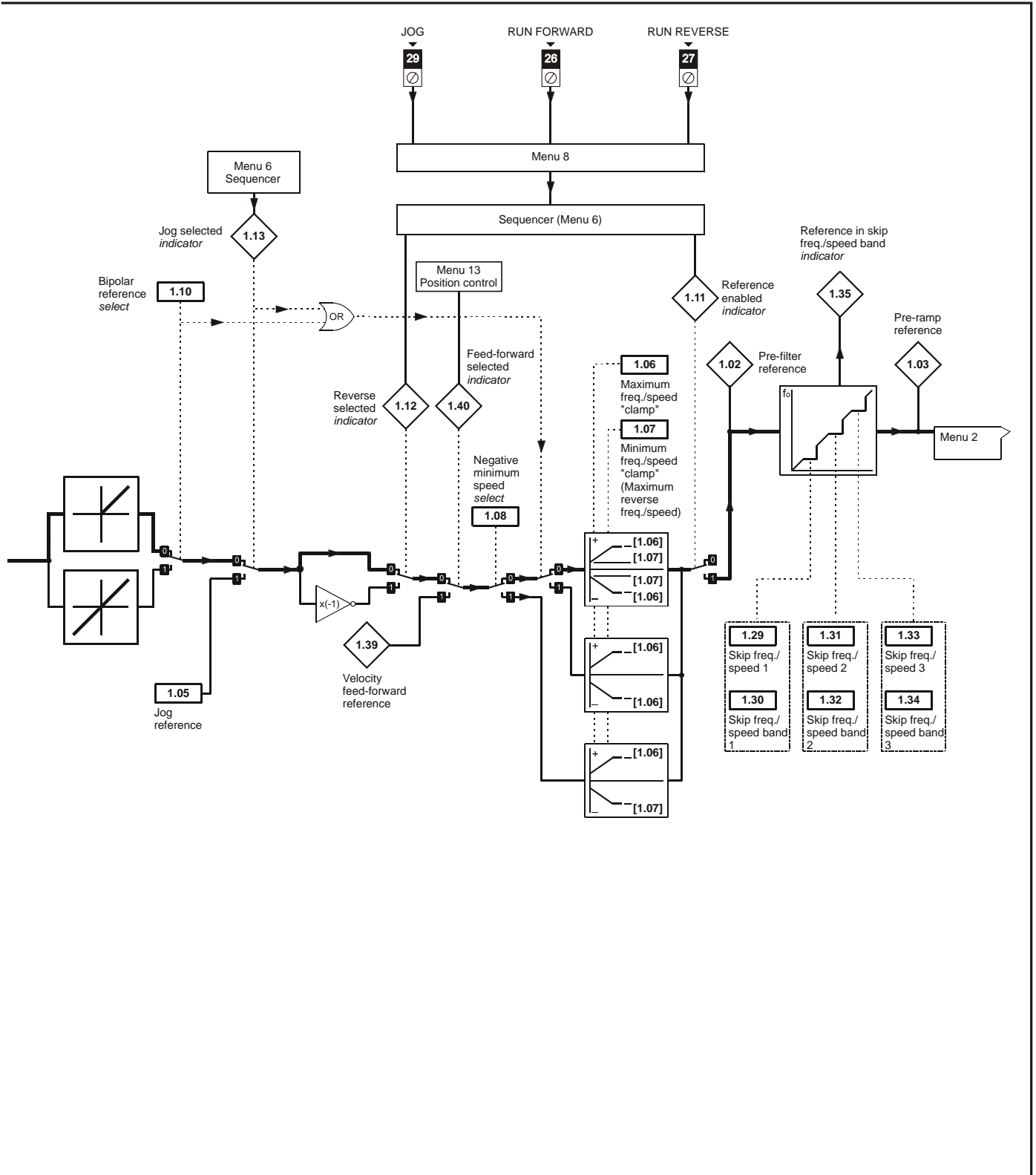
| Model  | $K_C$ | Maximum Heavy Duty current rating (Pr 11.32)<br>A | Maximum Normal Duty current rating<br>A |
|--------|-------|---|---|
| SP8411 | 293   | 333   | 389                                     |
| SP8412 | 342   | 389   | 437                                     |
| SP8413 | 391   | 440   | 545                                     |
| SP8414 | 472   | 545   | 620                                     |
| SP9411 | 586   | 620   | 690                                     |
| SP9412 | 586   | 690   | 770                                     |
| SP9413 | 684   | 770   | 864                                     |
| SP9414 | 782   | 864   | 990                                     |
| SP9415 | 944   | 990   | 1164                                    |

# 11.1 Menu 1: Frequency / speed reference

Figure 11-1 Menu 1 logic diagram



\*For more information, refer to section 11.21.1 Reference modes on page 248.



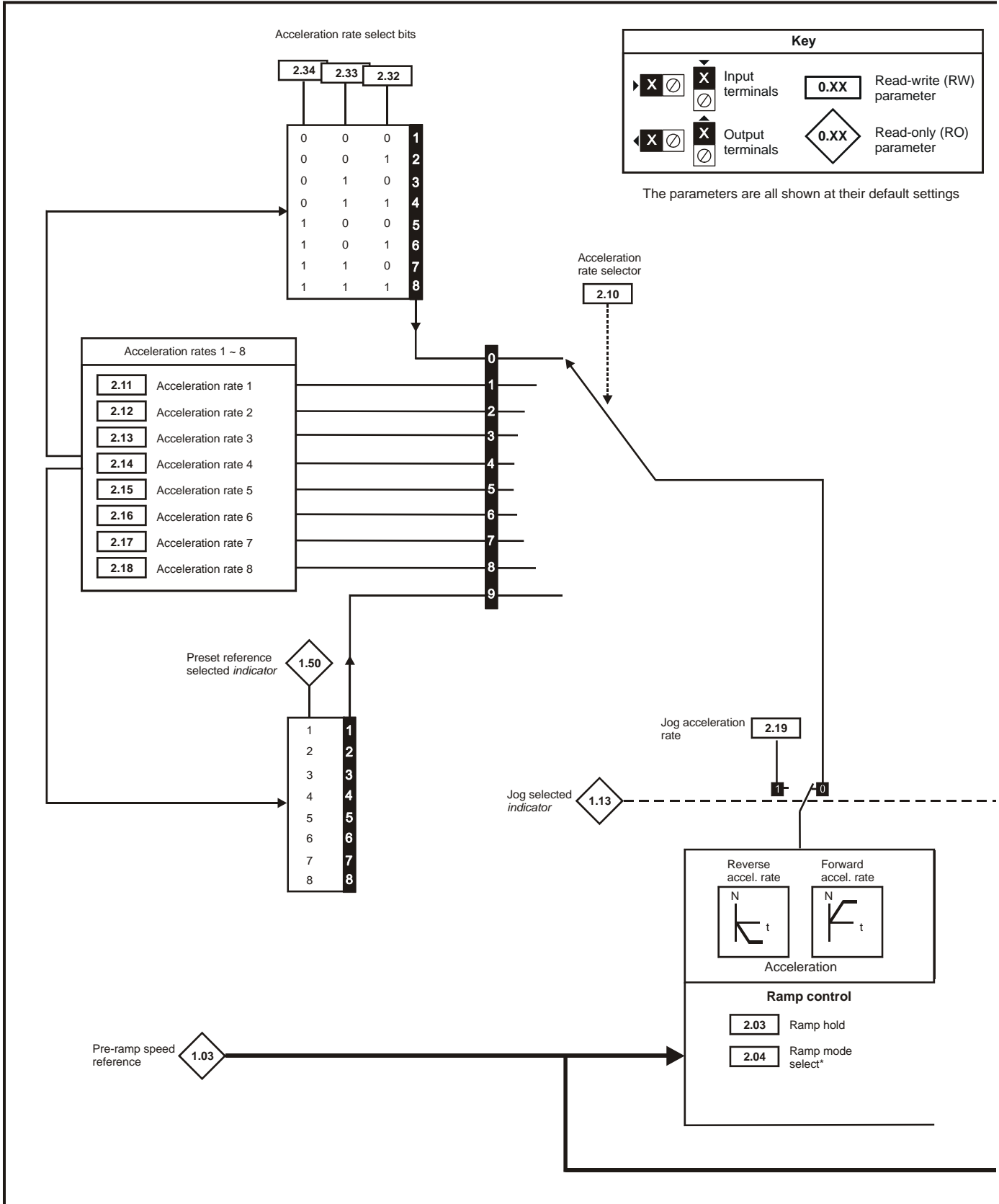
| Parameter |  | Range(⇅)  |                      | Default(⇒)             |                              |         | Type |     |    |    |    |    |
|-----------|--|---|----------------------|------------------------|------------------------------|---------|------|-----|----|----|----|----|
|           |  | OL  | CL                   | OL                     | VT                           | SV      | RO   | Bi  | NC | PT |    |    |
| 1.01      | Frequency / speed reference selected     | ±SPEED_FREQ_MAX Hz/rpm                                    |                      |                        |                              |         | RO   | Bi  | NC | PT |    |    |
| 1.02      | Pre-skip filter reference                | ±SPEED_FREQ_MAX Hz/rpm                                    |                      |                        |                              |         | RO   | Bi  | NC | PT |    |    |
| 1.03      | Pre-ramp reference                       | ±SPEED_FREQ_MAX Hz/rpm                                    |                      |                        |                              |         | RO   | Bi  | NC | PT |    |    |
| 1.04      | Reference offset                         | ±3,000.0Hz  | ±40,000.0 rpm        | 0.0                    |                              |         | RW   | Bi  |    |    |    | US |
| 1.05      | Jog reference {0.23}                     | 0 to 400.0 Hz   | 0 to 4,000.0 rpm     | 0.0                    |                              |         | RW   | Uni |    |    |    | US |
| 1.06      | Maximum reference clamp {0.02}           | 0 to 3,000.0 Hz   | SPEED_LIMIT_MAX rpm  | EUR> 50.0<br>USA> 60.0 | EUR> 1,500.0<br>USA> 1,800.0 | 3,000.0 | RW   | Uni |    |    |    | US |
| 1.07      | Minimum reference clamp {0.01}           | ±3,000.0 Hz   | ±SPEED_LIMIT_MAX rpm | 0.0                    |                              |         | RW   | Bi  |    |    | PT | US |
| 1.08      | Negative minimum reference clamp enable  | OFF (0) or On (1)   |                      | OFF (0)                |                              |         | RW   | Bit |    |    |    | US |
| 1.09      | Reference offset select                  | OFF (0) or On (1)   |                      | OFF (0)                |                              |         | RW   | Bit |    |    |    | US |
| 1.10      | Bipolar reference enable {0.22}          | OFF (0) or On (1)   |                      | OFF (0)                |                              |         | RW   | Bit |    |    |    | US |
| 1.11      | Reference enabled indicator              | OFF (0) or On (1)   |                      |                        |                              |         | RO   | Bit | NC | PT |    |    |
| 1.12      | Reverse selected indicator               | OFF (0) or On (1)   |                      |                        |                              |         | RO   | Bit | NC | PT |    |    |
| 1.13      | Jog selected indicator                   | OFF (0) or On (1)   |                      |                        |                              |         | RO   | Bit | NC | PT |    |    |
| 1.14      | Reference selector {0.05}                | A1.A2 (0), A1.Pr (1), A2.Pr (2), Pr (3), PAd (4), Prc (5) |                      | A1.A2 (0)              |                              |         | RW   | Txt |    |    |    | US |
| 1.15      | Preset reference selector                | 0 to 9  |                      | 0                      |                              |         | RW   | Uni |    |    |    | US |
| 1.16      | Preset reference selector timer          | 0 to 400.0s   |                      | 10.0                   |                              |         | RW   | Uni |    |    |    | US |
| 1.17      | Keypad control mode reference            | ±SPEED_FREQ_MAX Hz/rpm                                    |                      | 0.0                    |                              |         | RO   | Bi  | NC | PT | PS |    |
| 1.18      | Precision reference coarse               | ±SPEED_FREQ_MAX Hz/rpm                                    |                      | 0.0                    |                              |         | RW   | Bi  |    |    |    | US |
| 1.19      | Precision reference fine                 | 0.000 to 0.099 Hz   | 0.000 to 0.099 rpm   | 0.000                  |                              |         | RW   | Uni |    |    |    | US |
| 1.20      | Precision reference update disable       | OFF (0) or On (1)   |                      | OFF (0)                |                              |         | RW   | Bit | NC |    |    |    |
| 1.21      | Preset reference 1 {0.24}                | ±SPEED_FREQ_MAX Hz/rpm                                    |                      | 0.0                    |                              |         | RW   | Bi  |    |    |    | US |
| 1.22      | Preset reference 2 {0.25}                | ±SPEED_FREQ_MAX Hz/rpm                                    |                      | 0.0                    |                              |         | RW   | Bi  |    |    |    | US |
| 1.23      | Preset reference 3 {0.26}                | ±SPEED_FREQ_MAX Hz/rpm                                    |                      | 0.0                    |                              |         | RW   | Bi  |    |    |    | US |
| 1.24      | Preset reference 4 {0.27}                | ±SPEED_FREQ_MAX Hz/rpm                                    |                      | 0.0                    |                              |         | RW   | Bi  |    |    |    | US |
| 1.25      | Preset reference 5                       | ±SPEED_FREQ_MAX Hz/rpm                                    |                      | 0.0                    |                              |         | RW   | Bi  |    |    |    | US |
| 1.26      | Preset reference 6                       | ±SPEED_FREQ_MAX Hz/rpm                                    |                      | 0.0                    |                              |         | RW   | Bi  |    |    |    | US |
| 1.27      | Preset reference 7                       | ±SPEED_FREQ_MAX Hz/rpm                                    |                      | 0.0                    |                              |         | RW   | Bi  |    |    |    | US |
| 1.28      | Preset reference 8                       | ±SPEED_FREQ_MAX Hz/rpm                                    |                      | 0.0                    |                              |         | RW   | Bi  |    |    |    | US |
| 1.29      | Skip reference 1                         | 0.0 to 3,000.0 Hz   | 0 to 40,000 rpm      | 0.0                    | 0                            |         | RW   | Uni |    |    |    | US |
| 1.30      | Skip reference band 1                    | 0.0 to 25.0 Hz  | 0 to 250 rpm         | 0.5                    | 5                            |         | RW   | Uni |    |    |    | US |
| 1.31      | Skip reference 2                         | 0.0 to 3,000.0 Hz   | 0 to 40,000 rpm      | 0.0                    | 0                            |         | RW   | Uni |    |    |    | US |
| 1.32      | Skip reference band 2                    | 0.0 to 25.0 Hz  | 0 to 250 rpm         | 0.5                    | 5                            |         | RW   | Uni |    |    |    | US |
| 1.33      | Skip reference 3                         | 0.0 to 3,000.0 Hz   | 0 to 40,000 rpm      | 0.0                    | 0                            |         | RW   | Uni |    |    |    | US |
| 1.34      | Skip reference band 3                    | 0.0 to 25.0Hz   | 0 to 250 rpm         | 0.5                    | 5                            |         | RW   | Uni |    |    |    | US |
| 1.35      | Reference in rejection zone              | OFF (0) or On (1)   |                      |                        |                              |         | RO   | Bit | NC | PT |    |    |
| 1.36      | Analogue reference 1                     | ±SPEED_FREQ_MAX Hz/rpm                                    |                      |                        |                              |         | RO   | Bi  | NC |    |    |    |
| 1.37      | Analogue reference 2                     | ±SPEED_FREQ_MAX Hz/rpm                                    |                      |                        |                              |         | RO   | Bi  | NC |    |    |    |
| 1.38      | Percentage trim                          | ±100.00%  |                      | 0.00                   |                              |         | RW   | Bi  | NC |    |    |    |
| 1.39      | Velocity feed-forward                    | ±3,000.0 Hz   | ±40,000.0 rpm        |                        |                              |         | RO   | Bi  | NC | PT |    |    |
| 1.40      | Velocity feed-forward select             | OFF (0) or On (1)   |                      |                        |                              |         | RO   | Bit | NC | PT |    |    |
| 1.41      | Analogue reference 2 select              | OFF (0) or On (1)   |                      | OFF (0)                |                              |         | RW   | Bit | NC |    |    |    |
| 1.42      | Preset reference select                  | OFF (0) or On (1)   |                      | OFF (0)                |                              |         | RW   | Bit | NC |    |    |    |
| 1.43      | Keypad reference select                  | OFF (0) or On (1)   |                      | OFF (0)                |                              |         | RW   | Bit | NC |    |    |    |
| 1.44      | Precision reference select               | OFF (0) or On (1)   |                      | OFF (0)                |                              |         | RW   | Bit | NC |    |    |    |
| 1.45      | Preset reference 1 select                | OFF (0) or On (1)   |                      | OFF (0)                |                              |         | RW   | Bit | NC |    |    |    |
| 1.46      | Preset reference 2 select                | OFF (0) or On (1)   |                      | OFF (0)                |                              |         | RW   | Bit | NC |    |    |    |
| 1.47      | Preset reference 3 select                | OFF (0) or On (1)   |                      | OFF (0)                |                              |         | RW   | Bit | NC |    |    |    |
| 1.48      | Reference timer reset flag               | OFF (0) or On (1)   |                      | OFF (0)                |                              |         | RW   | Bit | NC |    |    |    |
| 1.49      | Reference selected indicator             | 1 to 5  |                      |                        |                              |         | RO   | Uni | NC | PT |    |    |
| 1.50      | Preset reference selected indicator      | 1 to 8  |                      |                        |                              |         | RO   | Uni | NC | PT |    |    |
| 1.51      | Power-up keyboard control mode reference | rESET (0), LAsT (1), PrS1 (2)                             |                      | rESET (0)              |                              |         | RW   | Txt |    |    |    | US |

|    |              |    |             |     |            |    |                  |     |               |     |             |    |                 |
|----|--------------|----|-------------|-----|------------|----|------------------|-----|---------------|-----|-------------|----|-----------------|
| RW | Read / Write | RO | Read only   | Uni | Unipolar   | Bi | Bi-polar         | Bit | Bit parameter | Txt | Text string |    |                 |
| FI | Filtered     | DE | Destination | NC  | Not cloned | RA | Rating dependent | PT  | Protected     | US  | User save   | PS | Power down save |



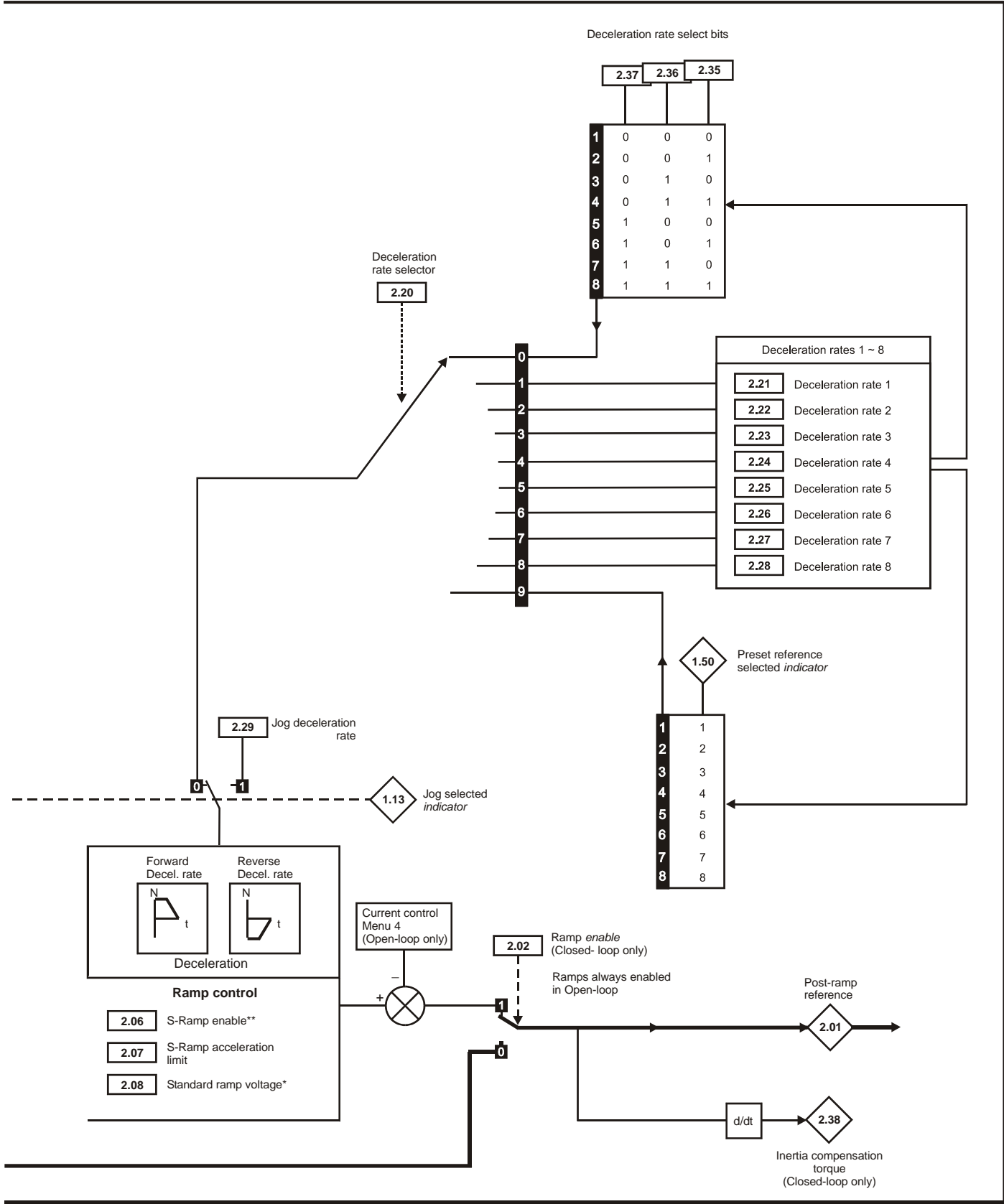
## 11.2 Menu 2: Ramps

Figure 11-2 Menu 2 logic diagram



\*For more information, refer to section 11.21.2 *Braking Modes* on page 249.

\*\*For more information, refer to section 11.21.3 *S ramps* on page 249.

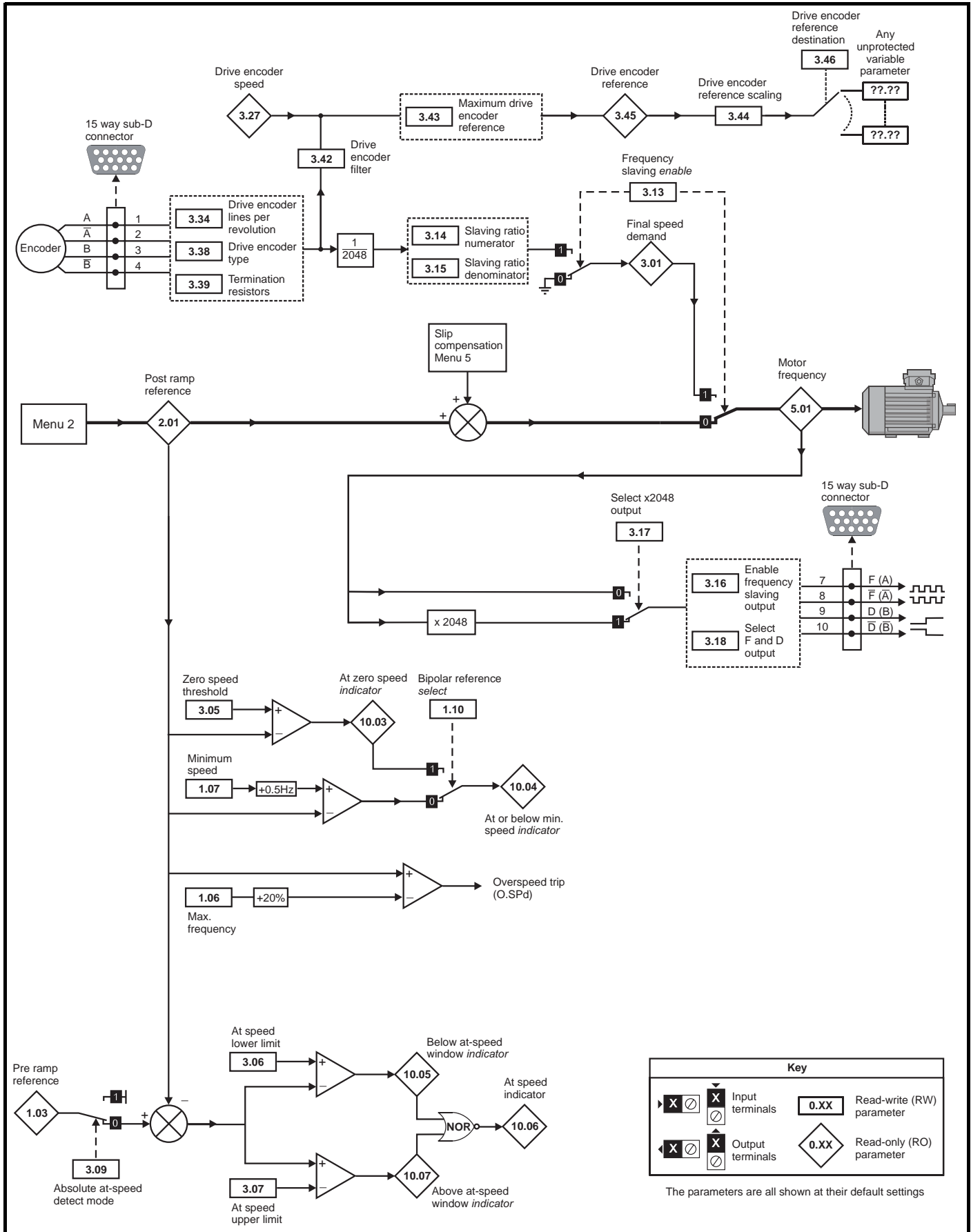


| Parameter                        | Range(⇅)                              |   | Default(⇨)   |       |       | Type |     |    |    |
|----------------------------------|---------------------------------------|---|--|-------|-------|------|-----|----|----|
|                                  | OL                                    | CL  | OL   | VT    | SV    | RO   | Bi  | NC | PT |
| 2.01 Post ramp reference         | ±SPEED_FREQ_MAX Hz/rpm                |   |  |       |       | RO   | Bi  | NC | PT |
| 2.02 Ramp enable {0.16}          | OFF (0) or On (1)                     |   | On (1)   |       |       | RW   | Bit |    | US |
| 2.03 Ramp hold                   | OFF (0) or On (1)                     |   | OFF (0)  |       |       | RW   | Bit |    | US |
| 2.04 Ramp mode select {0.15}     | FAST (0)<br>Std (1)<br>Std.hV (2)     | FAST (0)<br>Std (1)                         | Std (1)  |       |       | RW   | Txt |    | US |
| 2.06 S ramp enable               | OFF (0) or On (1)                     |   | OFF (0)  |       |       | RW   | Bit |    | US |
| 2.07 S ramp acceleration limit   | 0.0 to 300.0<br>s <sup>2</sup> /100Hz | 0.000 to 100.000<br>s <sup>2</sup> /1000rpm | 3.1  | 1.500 | 0.030 | RW   | Uni |    | US |
| 2.08 Standard ramp voltage       | 0 to DC_VOLTAGE_SET_MAX V             |   | 200V drive: 375<br>400V drive: EUR> 750<br>USA> 775<br>575V drive: 895<br>690V drive: 1075 |       |       | RW   | Uni | RA | US |
| 2.10 Acceleration rate selector  | 0 to 9                                |   | 0  |       |       | RW   | Uni |    | US |
| 2.11 Acceleration rate 1 {0.03}  | 0.0 to 3,200.0<br>s/100Hz             | 0.000 to 3,200.000<br>s/1,000rpm            | 5.0  | 2.000 | 0.200 | RW   | Uni |    | US |
| 2.12 Acceleration rate 2         | 0.0 to 3,200.0<br>s/100Hz             | 0.000 to 3,200.000<br>s/1,000rpm            | 5.0  | 2.000 | 0.200 | RW   | Uni |    | US |
| 2.13 Acceleration rate 3         | 0.0 to 3,200.0<br>s/100Hz             | 0.000 to 3,200.000<br>s/1,000rpm            | 5.0  | 2.000 | 0.200 | RW   | Uni |    | US |
| 2.14 Acceleration rate 4         | 0.0 to 3,200.0<br>s/100Hz             | 0.000 to 3,200.000<br>s/1,000rpm            | 5.0  | 2.000 | 0.200 | RW   | Uni |    | US |
| 2.15 Acceleration rate 5         | 0.0 to 3,200.0<br>s/100Hz             | 0.000 to 3,200.000<br>s/1,000rpm            | 5.0  | 2.000 | 0.200 | RW   | Uni |    | US |
| 2.16 Acceleration rate 6         | 0.0 to 3,200.0<br>s/100Hz             | 0.000 to 3,200.000<br>s/1,000rpm            | 5.0  | 2.000 | 0.200 | RW   | Uni |    | US |
| 2.17 Acceleration rate 7         | 0.0 to 3,200.0<br>s/100Hz             | 0.000 to 3,200.000<br>s/1,000rpm            | 5.0  | 2.000 | 0.200 | RW   | Uni |    | US |
| 2.18 Acceleration rate 8         | 0.0 to 3,200.0<br>s/100Hz             | 0.000 to 3,200.000<br>s/1,000rpm            | 5.0  | 2.000 | 0.200 | RW   | Uni |    | US |
| 2.19 Jog acceleration rate       | 0.0 to 3,200.0<br>s/100Hz             | 0.000 to 3,200.000<br>s/1,000rpm            | 0.2  | 0.000 |       | RW   | Uni |    | US |
| 2.20 Deceleration rate selector  | 0 to 9                                |   | 0  |       |       | RW   | Uni |    | US |
| 2.21 Deceleration rate 1 {0.04}  | 0.0 to 3,200.0<br>s/100Hz             | 0.000 to 3,200.000<br>s/1,000rpm            | 10.0   | 2.000 | 0.200 | RW   | Uni |    | US |
| 2.22 Deceleration rate 2         | 0.0 to 3,200.0<br>s/100Hz             | 0.000 to 3,200.000<br>s/1,000rpm            | 10.0   | 2.000 | 0.200 | RW   | Uni |    | US |
| 2.23 Deceleration rate 3         | 0.0 to 3,200.0<br>s/100Hz             | 0.000 to 3,200.000<br>s/1,000rpm            | 10.0   | 2.000 | 0.200 | RW   | Uni |    | US |
| 2.24 Deceleration rate 4         | 0.0 to 3,200.0<br>s/100Hz             | 0.000 to 3,200.000<br>s/1,000rpm            | 10.0   | 2.000 | 0.200 | RW   | Uni |    | US |
| 2.25 Deceleration rate 5         | 0.0 to 3,200.0<br>s/100Hz             | 0.000 to 3,200.000<br>s/1,000rpm            | 10.0   | 2.000 | 0.200 | RW   | Uni |    | US |
| 2.26 Deceleration rate 6         | 0.0 to 3,200.0<br>s/100Hz             | 0.000 to 3,200.000<br>s/1,000rpm            | 10.0   | 2.000 | 0.200 | RW   | Uni |    | US |
| 2.27 Deceleration rate 7         | 0.0 to 3,200.0<br>s/100Hz             | 0.000 to 3,200.000<br>s/1,000rpm            | 10.0   | 2.000 | 0.200 | RW   | Uni |    | US |
| 2.28 Deceleration rate 8         | 0.0 to 3,200.0<br>s/100Hz             | 0.000 to 3,200.000<br>s/1,000rpm            | 10.0   | 2.000 | 0.200 | RW   | Uni |    | US |
| 2.29 Jog deceleration rate       | 0.0 to 3,200.0<br>s/100Hz             | 0.000 to 3,200.000<br>s/1,000rpm            | 0.2  | 0.000 |       | RW   | Uni |    | US |
| 2.32 Acceleration select bit 0   | OFF (0) or On (1)                     |   | OFF (0)  |       |       | RW   | Bit | NC |    |
| 2.33 Acceleration select bit 1   | OFF (0) or On (1)                     |   | OFF (0)  |       |       | RW   | Bit | NC |    |
| 2.34 Acceleration select bit 2   | OFF (0) or On (1)                     |   | OFF (0)  |       |       | RW   | Bit | NC |    |
| 2.35 Deceleration select bit 0   | OFF (0) or On (1)                     |   | OFF (0)  |       |       | RW   | Bit | NC |    |
| 2.36 Deceleration select bit 1   | OFF (0) or On (1)                     |   | OFF (0)  |       |       | RW   | Bit | NC |    |
| 2.37 Deceleration select bit 2   | OFF (0) or On (1)                     |   | OFF (0)  |       |       | RW   | Bit | NC |    |
| 2.38 Inertia compensation torque | ± 1,000.0 %                           |   |  |       |       | RO   | Bi  | NC | PT |

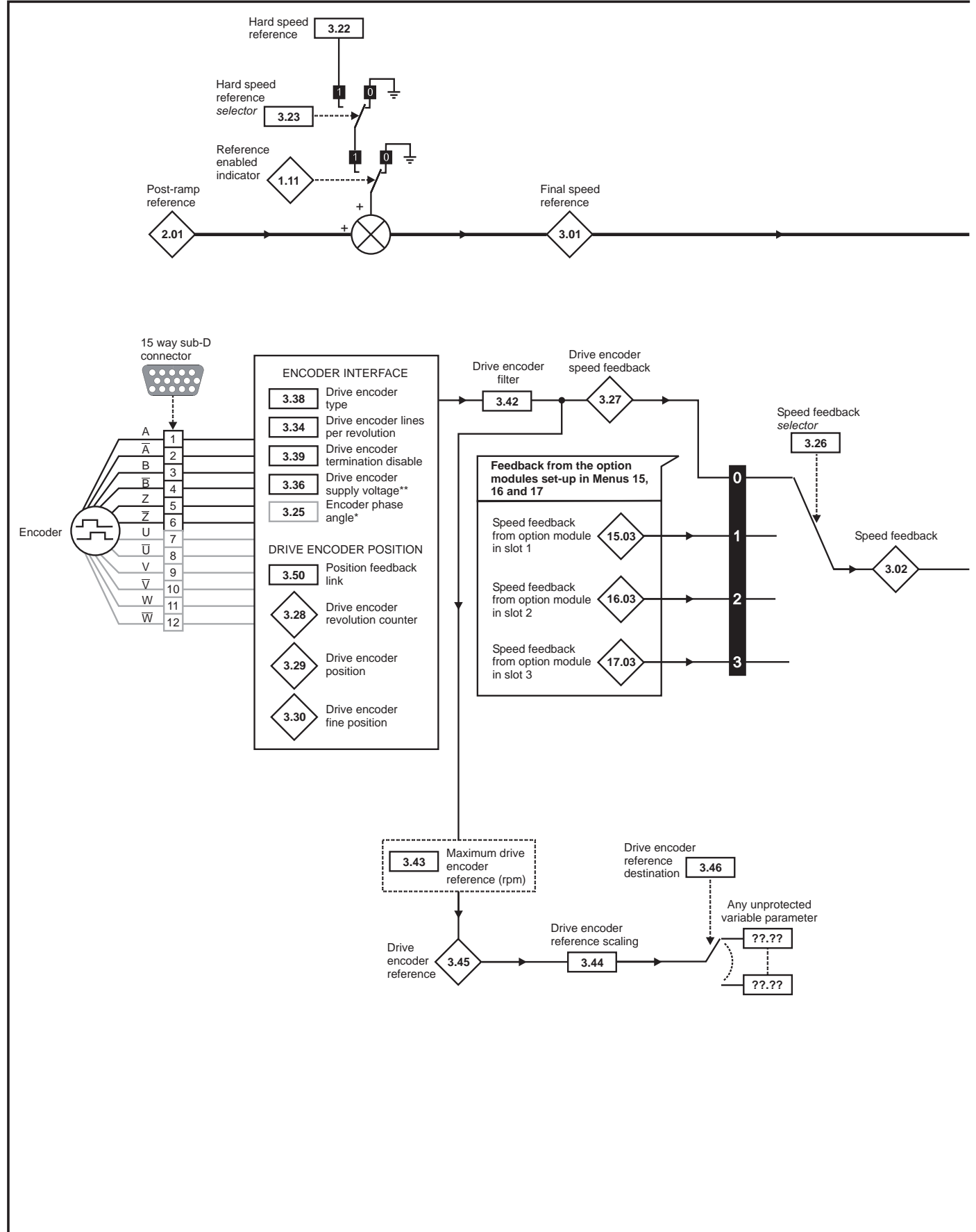
|    |              |    |             |     |            |    |                  |     |               |     |             |    |                 |
|----|--------------|----|-------------|-----|------------|----|------------------|-----|---------------|-----|-------------|----|-----------------|
| RW | Read / Write | RO | Read only   | Uni | Unipolar   | Bi | Bi-polar         | Bit | Bit parameter | Txt | Text string |    |                 |
| FI | Filtered     | DE | Destination | NC  | Not cloned | RA | Rating dependent | PT  | Protected     | US  | User save   | PS | Power down save |

### 11.3 Menu 3: Frequency slaving, speed feedback and speed control

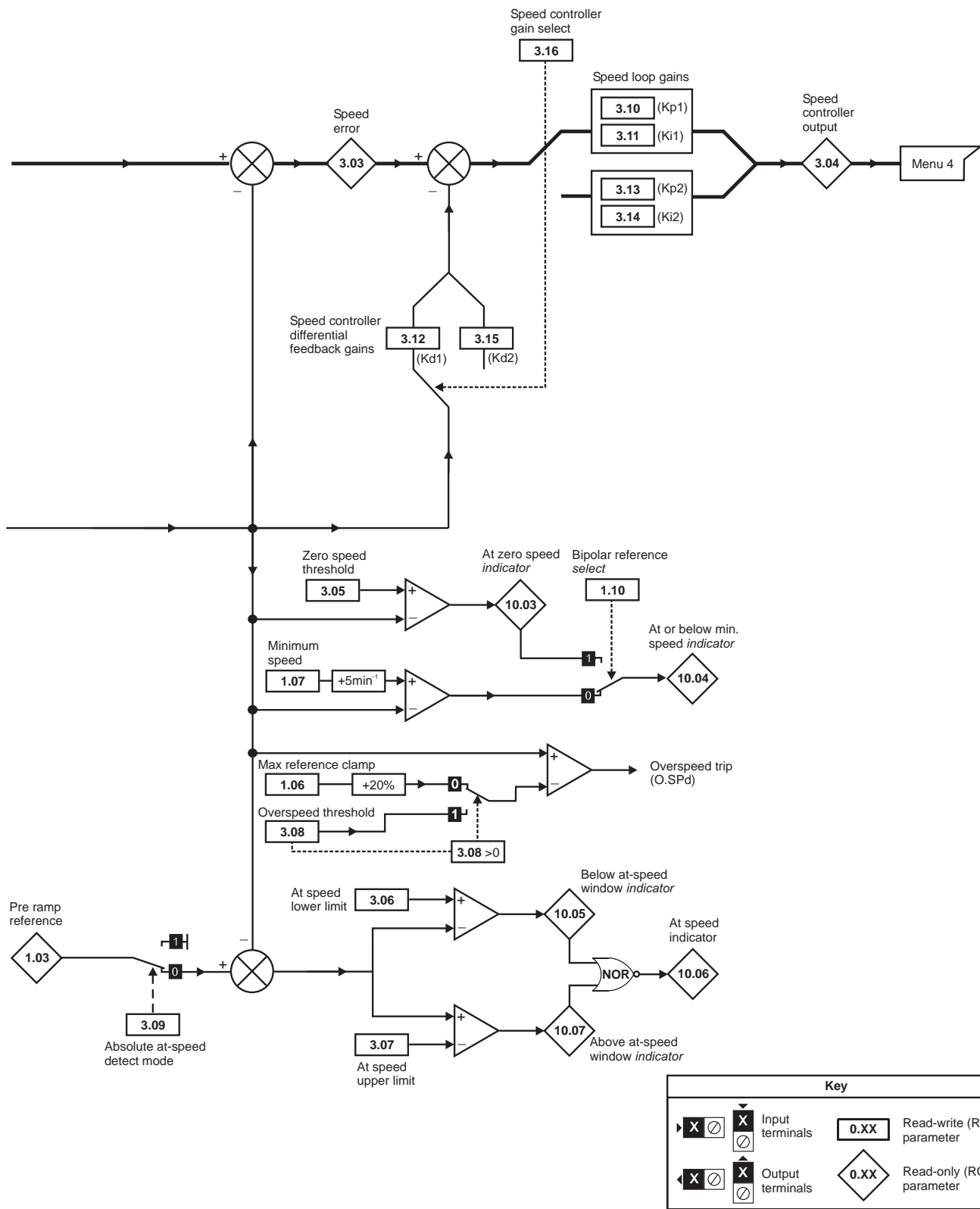
Figure 11-3 Menu 3 Open-loop logic diagram



**Figure 11-4 Menu 3 Closed loop logic diagram**



**NOTE** \*\*If Ab encoder voltage is greater than 5V, then the termination resistors must be disabled Pr 3.39 to 0.




The parameters are all shown at their default settings

| Parameter |  | Range(↕)   |   | Default(↔) |    |              | Type |     |    |    |    |  |    |
|-----------|--|--|---|------------|----|--------------|------|-----|----|----|----|--|----|
|           |  | OL   | CL  | OL         | VT | SV           |      |     |    |    |    |  |    |
| 3.01      | OL> Frequency slaving demand   | ±1,000.0 Hz  |   |            |    |              | RO   | Bi  | FI | NC | PT |  |    |
|           | CL> Final speed reference  |  | ±SPEED_MAX rpm  |            |    |              | RO   | Bi  | FI | NC | PT |  |    |
| 3.02      | Speed feedback {0.10}  |  | ±SPEED_MAX rpm  |            |    |              | RO   | Bi  | FI | NC | PT |  |    |
| 3.03      | Speed error  |  | ±SPEED_MAX rpm  |            |    |              | RO   | Bi  | FI | NC | PT |  |    |
| 3.04      | Speed controller output  |  | ±Torque_prod_current_max %                              |            |    |              | RO   | Bi  | FI | NC | PT |  |    |
| 3.05      | Zero speed threshold   | 0.0 to 20.0 Hz   | 0 to 200 rpm  | 1.0        |    | 5            | RW   | Uni |    |    |    |  | US |
| 3.06      | At speed lower limit   | 0.0 to 3,000.0 Hz  | 0 to 40,000 rpm   | 1.0        |    | 5            | RW   | Uni |    |    |    |  | US |
| 3.07      | At speed upper limit   | 0.0 to 3,000.0 Hz  | 0 to 40,000 rpm   | 1.0        |    | 5            | RW   | Uni |    |    |    |  | US |
| 3.08      | Overspeed threshold {0.26}   |  | 0 to 40,000 rpm   |            |    | 0            | RW   | Uni |    |    |    |  | US |
| 3.09      | Absolute 'at speed' detect   | OFF (0) or On (1)  |   | OFF (0)    |    |              | RW   | Bit |    |    |    |  | US |
| 3.10      | Speed controller proportional gain (Kp1) {0.07}                                    |  | 0.0000 to 6.5535 1/rad s <sup>-1</sup>                  |            |    | 0.0100       | RW   | Uni |    |    |    |  | US |
| 3.11      | Speed controller integral gain (Ki1) {0.08}  |  | 0.00 to 655.35 s/rad s <sup>-1</sup>                    |            |    | 1.00         | RW   | Uni |    |    |    |  | US |
| 3.12      | Speed controller differential feedback gain (Kd1) {0.09}                           |  | 0.00000 to 0.65535 s <sup>-1</sup> /rad s <sup>-1</sup> |            |    | 0.00000      | RW   | Uni |    |    |    |  | US |
| 3.13      | OL> Enable frequency slaving   | OFF (0) or On (1)  |   | OFF (0)    |    |              | RW   | Bit |    |    |    |  | US |
|           | CL> Speed controller proportional gain (Kp2)                                       |  | 0.0000 to 6.5535 1/rad s <sup>-1</sup>                  |            |    | 0.0100       | RW   | Uni |    |    |    |  | US |
| 3.14      | OL> Slaving ratio numerator  | 0.000 to 1.000   |   | 1.000      |    |              | RW   | Uni |    |    |    |  | US |
|           | CL> Speed controller integral gain (Ki2)   |  | 0.00 to 655.35 1/rad                                    |            |    | 1.00         | RW   | Uni |    |    |    |  | US |
| 3.15      | OL> Slaving ratio denominator  | 0.001 to 1.000   |   | 1.000      |    |              | RW   | Uni |    |    |    |  | US |
|           | CL> Speed controller differential feedback gain (Kd2)                              |  | 0.00000 to 0.65535 s                                    |            |    | 0.00000      | RW   | Uni |    |    |    |  | US |
| 3.16      | OL> Enable frequency slaving output  | OFF (0) or On (1)  |   | OFF (0)    |    |              | RW   | Bit |    |    |    |  | US |
|           | CL> Speed controller gain select   |  | OFF (0) or On (1)                                       |            |    | OFF (0)      | RW   | Bit |    |    |    |  | US |
| 3.17      | OL> Select x2048 output  | OFF (0) or On (1)  |   | On (1)     |    |              | RW   | Bit |    |    |    |  | US |
|           | CL> Speed controller set-up method   |  | 0 to 3  |            |    | 0            | RW   | Uni |    |    |    |  | US |
| 3.18      | OL> Select F and D frequency slaving output  | OFF (0) or On (1)  |   | OFF (0)    |    |              | RW   | Bit |    |    |    |  | US |
|           | CL> Motor and load inertia   |  | 0.00010 to 90.00000 kg m <sup>2</sup>                   |            |    | 0.00000      | RW   | Uni |    |    |    |  | US |
| 3.19      | Compliance angle   |  | 0.0 to 359.9 °  |            |    | 4.0          | RW   | Uni |    |    |    |  | US |
| 3.20      | Bandwidth  |  | 0 to 255 Hz   |            |    | 10           | RW   | Uni |    |    |    |  | US |
| 3.21      | Damping factor   |  | 0.0 to 10.0   |            |    | 1.0          | RW   | Uni |    |    |    |  | US |
| 3.22      | Hard speed reference   |  | ±SPEED_FREQ_MAX rpm                                     |            |    | 0.0          | RW   | Bi  |    |    |    |  | US |
| 3.23      | Hard speed reference selector  |  | OFF (0) or On (1)                                       |            |    | OFF (0)      | RW   | Bit |    |    |    |  | US |
| 3.24      | Closed-loop vector mode  |  | VT> 0 to 3  |            |    | 0            | RW   | Uni |    |    |    |  | US |
| 3.25      | Encoder phase angle* {0.43}  |  | SV> 0.0 to 359.9 °                                      |            |    | 0.0          | RW   | Uni |    |    |    |  | US |
| 3.26      | Speed feedback selector  |  | drv (0), SSlot1 (1), SSlot2 (2), SSlot3 (3)             |            |    | drv (0)      | RW   | Txt |    |    |    |  | US |
| 3.27      | Drive encoder speed feedback   | ±40,000.0 rpm  |   |            |    |              | RO   | Bi  | FI | NC | PT |  |    |
| 3.28      | Drive encoder revolution counter   | 0 to 65,535 revolutions  |   |            |    |              | RO   | Uni | FI | NC | PT |  |    |
| 3.29      | Drive encoder position {0.11}  | 0 to 65,535 1/2 <sup>16</sup> ths of a revolution  |   |            |    |              | RO   | Uni | FI | NC | PT |  |    |
| 3.30      | Drive encoder fine position  | 0 to 65,535 1/2 <sup>32</sup> nds of a revolution  |   |            |    |              | RO   | Uni | FI | NC | PT |  |    |
| 3.31      | Drive encoder marker position reset disable  | OFF (0) or On (1)  |   | OFF (0)    |    |              | RW   | Bit |    |    |    |  | US |
| 3.32      | Drive encoder marker flag  | OFF (0) or On (1)  |   | OFF (0)    |    |              | RW   | Bit |    | NC |    |  |    |
| 3.33      | Drive encoder turn bits / Linear encoder comms to sine wave ratio                  | 0 to 255   |   | 16         |    |              | RW   | Uni |    |    |    |  | US |
| 3.34      | Drive encoder lines per revolution {0.27}  | 0 to 50,000  |   | 1024       |    | 4096         | RW   | Uni |    |    |    |  | US |
| 3.35      | Drive encoder single turn comms bits / Linear encoder comms bits / Marker mode     | 0 to 32 bits   |   | 0          |    |              | RW   | Uni |    |    |    |  | US |
| 3.36      | Drive encoder supply voltage**   | 5V (0), 8V (1), 15V (2)  |   | 5V (0)     |    |              | RW   | Txt |    |    |    |  | US |
| 3.37      | Drive encoder comms baud rate  | 100 (0), 200 (1), 300 (2), 400 (3), 500 (4), 1000 (5), 1500 (6), 2000 (7) kBaud  |   | 300 (2)    |    |              | RW   | Txt |    |    |    |  | US |
| 3.38      | Drive encoder type   | Ab (0), Fd (1), Fr (2), Ab.SErvo (3), Fd.SErvo (4), Fr.SErvo (5), SC (6), SC.Hiper (7), EndAt (8), SC.EndAt (9), SSI (10), SC.SSI (11) |   | Ab (0)     |    | Ab.SErvo (3) | RW   | Txt |    |    |    |  | US |
| 3.39      | Drive encoder termination select / Rotary encoder select / Comms only encoder mode | 0 to 2   |   | 1          |    |              | RW   | Uni |    |    |    |  | US |
| 3.40      | Drive encoder error detection level  | Bit 0 (LSB) = Wire break detect<br>Bit 1 = Phase error detect<br>Bit 2 (MSB) = SSI power supply bit monitor<br>Value is binary sum     |   | 0          |    | 1            | RW   | Uni |    |    |    |  | US |
| 3.41      | Drive encoder auto-configuration / SSI binary format select                        | OFF (0) or On (1)  |   | OFF (0)    |    |              | RW   | Bit |    |    |    |  | US |

| Parameter  | Range(⇅)                                     |    | Default(⇔)     |    |    | Type |     |    |    |    |  |    |
|--|--|----|----------------|----|----|------|-----|----|----|----|--|----|
|  | OL   | CL | OL             | VT | SV | RW   | Txt |    |    |    |  |    |
| 3.42 Drive encoder filter                            | 0 (0), 1 (1), 2 (2), 4 (3), 8 (4), 16 (5) ms |    | 0              |    |    | RW   | Txt |    |    |    |  | US |
| 3.43 Maximum drive encoder reference                 | 0 to 40,000 rpm                              |    | 1500      3000 |    |    | RW   | Uni |    |    |    |  | US |
| 3.44 Drive encoder reference scaling                 | 0.000 to 4.000                               |    | 1.000          |    |    | RW   | Uni |    |    |    |  | US |
| 3.45 Drive encoder reference                         | ±100.0%                                      |    |                |    |    | RO   | Bi  | FI | NC | PT |  |    |
| 3.46 Drive encoder reference destination             | Pr <b>0.00</b> to <b>21.50</b>               |    | Pr <b>0.00</b> |    |    | RW   | Uni |    | DE | PT |  | US |
| 3.47 Re-initialise position feedback                 | OFF (0) or On (1)                            |    | OFF (0)        |    |    | RW   | Bit |    | NC |    |  |    |
| 3.48 Position feedback initialised                   | OFF (0) or On (1)                            |    |                |    |    | RO   | Bit |    | NC | PT |  |    |
| 3.49 Full motor object electronic nameplate transfer | OFF (0) or On (1)                            |    | OFF (0)        |    |    | RW   | Bit |    |    |    |  | US |
| 3.50 Position feedback lock                          | OFF (0) or On (1)                            |    | OFF (0)        |    |    | RW   | Bit |    | NC |    |  |    |

|    |              |    |             |     |            |    |                  |     |               |     |             |    |                 |
|----|--------------|----|-------------|-----|------------|----|------------------|-----|---------------|-----|-------------|----|-----------------|
| RW | Read / Write | RO | Read only   | Uni | Unipolar   | Bi | Bi-polar         | Bit | Bit parameter | Txt | Text string |    |                 |
| FI | Filtered     | DE | Destination | NC  | Not cloned | RA | Rating dependent | PT  | Protected     | US  | User save   | PS | Power down save |



**\*Encoder phase angle (servo mode only)**

With drive software version V01.08.00 onwards, the encoder phase angles in Pr **3.25** and Pr **21.20** are cloned to the SMARTCARD when using any of the SMARTCARD transfer methods.

With drive software version V01.05.00 to V01.07.01, the encoder phase angles in Pr **3.25** and Pr **21.20** are only cloned to the SMARTCARD when using either Pr **0.30** set to Prog (2) or Pr **xx.00** set to 3yyy.

This is useful when the SMARTCARD is used to back-up the parameter set of a drive but caution should be used if the SMARTCARD is used to transfer parameter sets between drives. Unless the encoder phase angle of the servo motor connected to the destination drive is known to be the same as the servo motor connected to the source drive, an autotune should be performed or the encoder phase angle should be entered manually into Pr **3.25** (or Pr **21.20**). If the encoder phase angle is incorrect the drive may lose control of the motor resulting in an O.SPd or Enc10 trip when the drive is enabled.

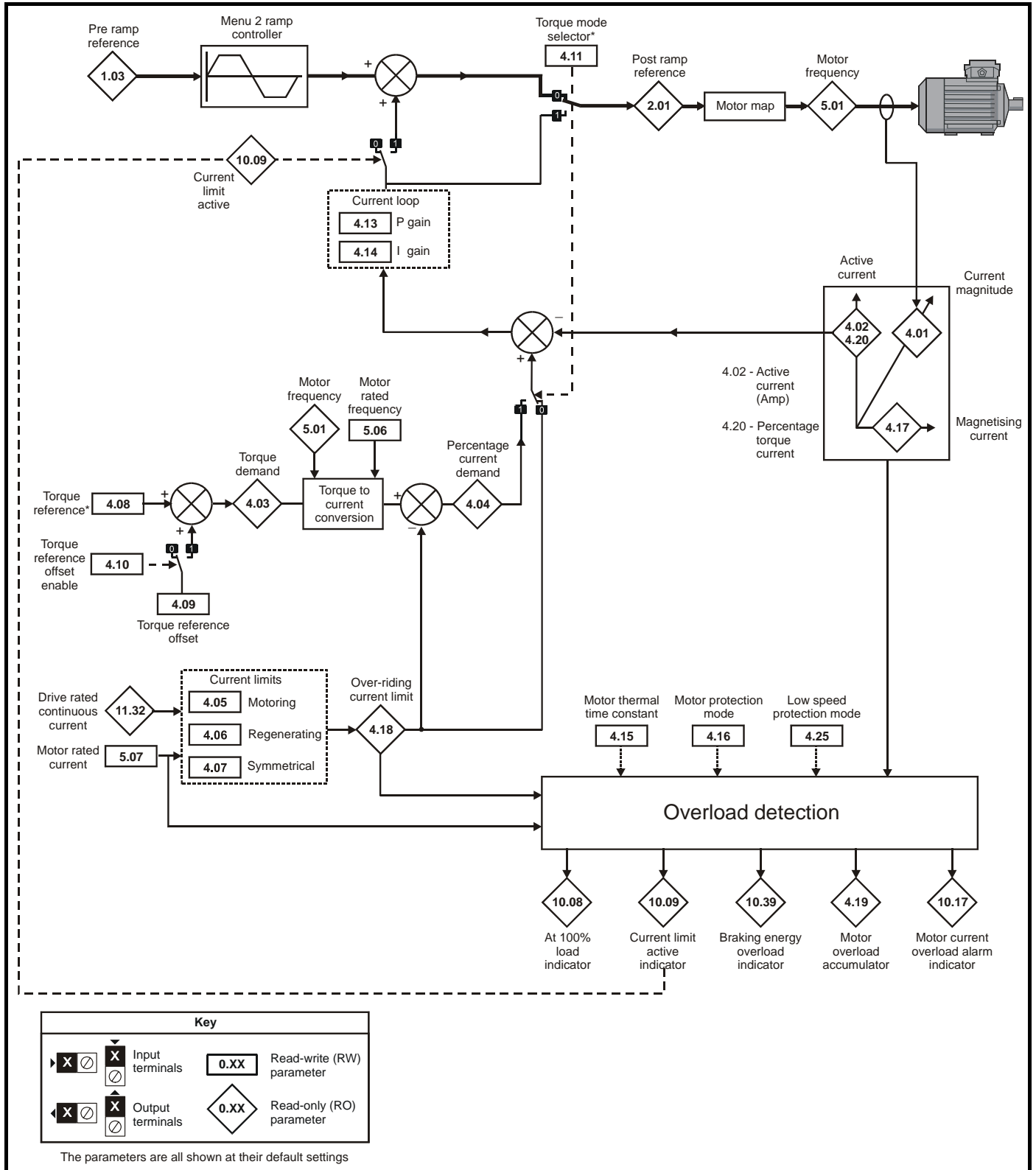
With drive software version V01.04.00 and earlier, or when using software version V01.05.00 to V01.07.01 and Pr **xx.00** set to 4yyy is used, then the encoder phase angles in Pr **3.25** and Pr **21.20** are not cloned to the SMARTCARD. Therefore, Pr **3.25** and Pr **21.20** in the destination would not be changed during a transfer of this data block from the SMARTCARD.

**NOTE**

\*\*If Ab encoder voltage is greater than 5V, then the termination resistors must be disabled Pr **3.39** to 0.

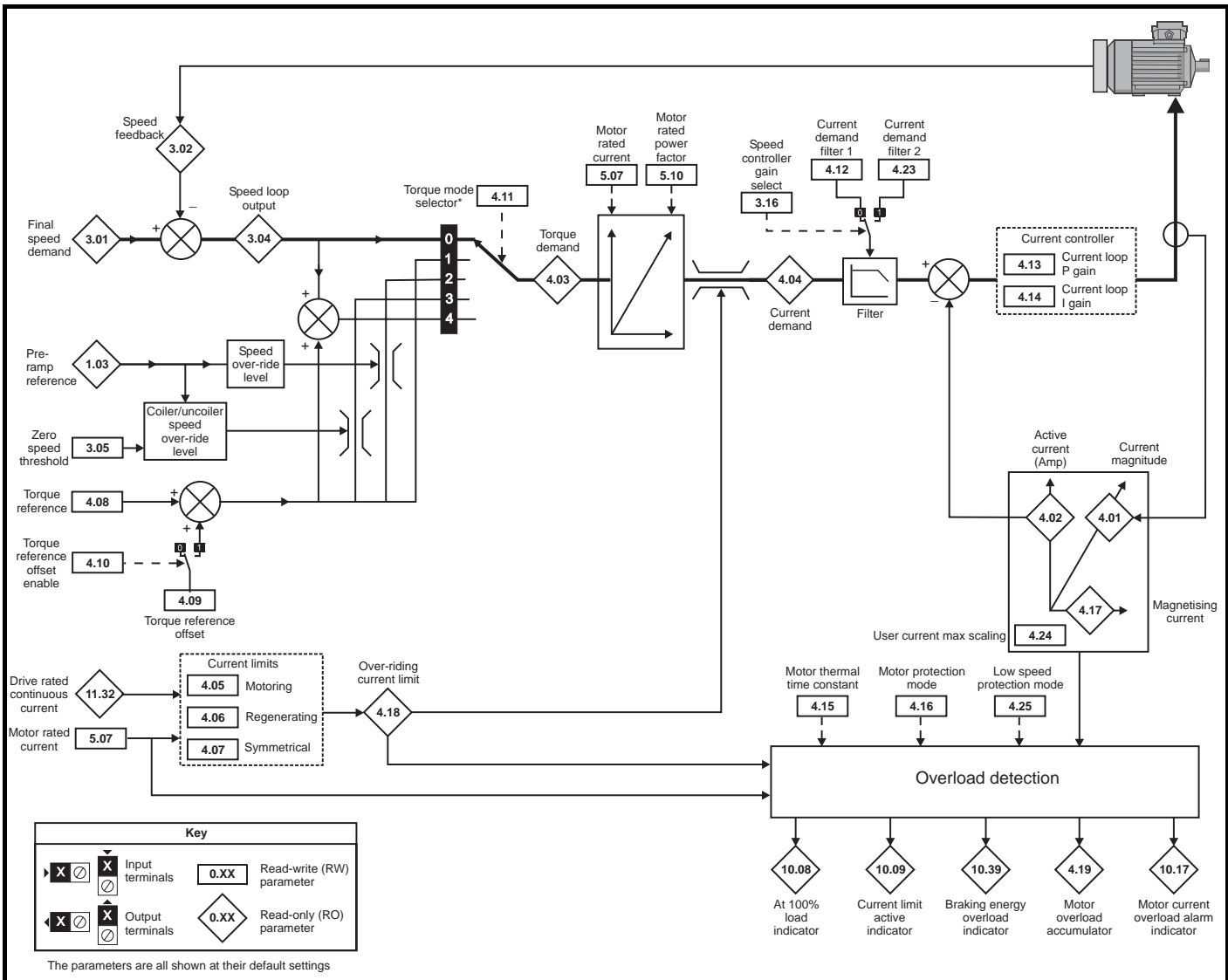
## 11.4 Menu 4: Torque and current control

Figure 11-5 Menu 4 Open loop logic diagram



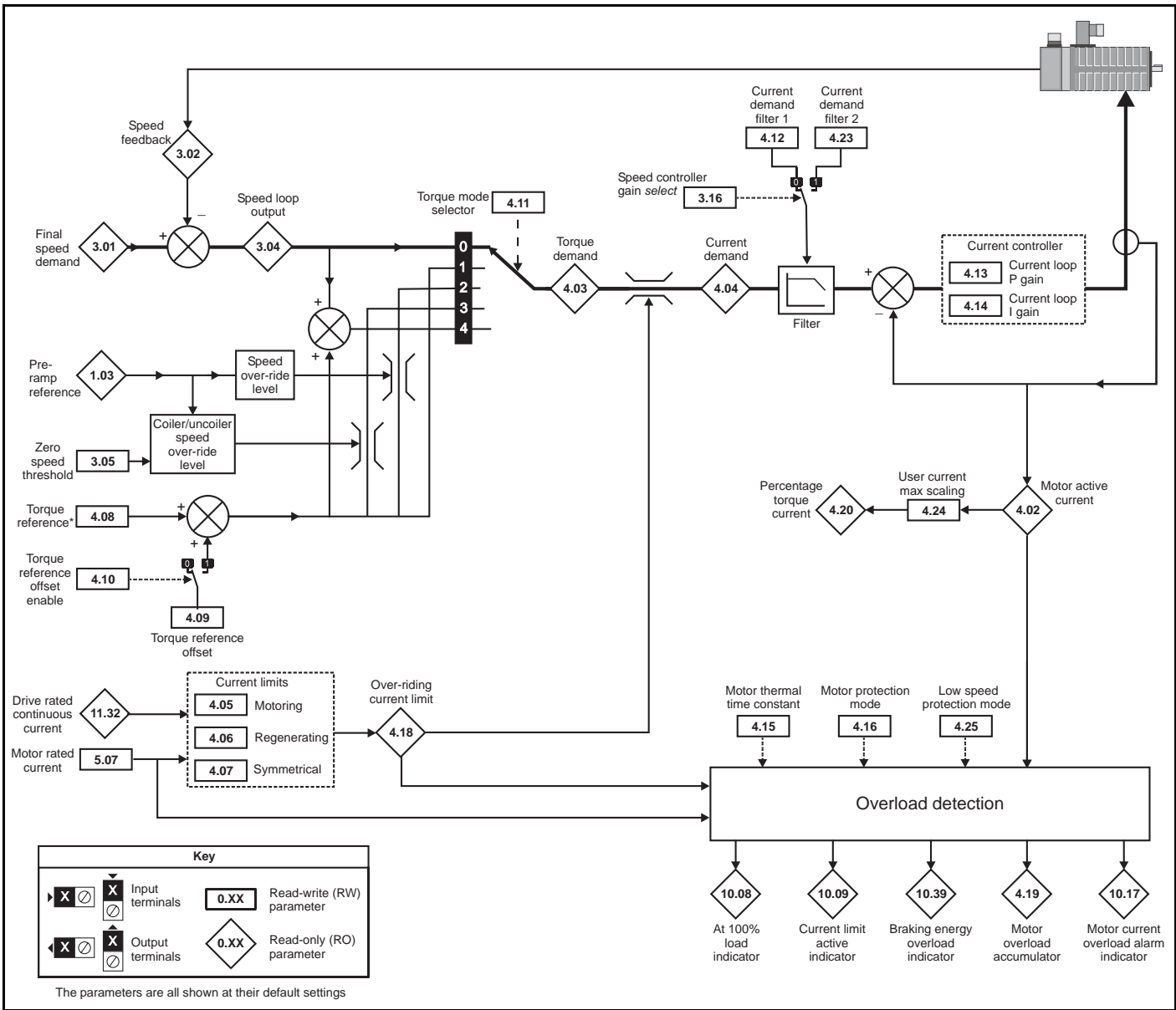
For more information, refer to section 11.21.4 *Torque modes* on page 250.

**Figure 11-6 Menu 4 Closed-loop vector logic diagram**



\*For more information, refer to section 11.21.4 Torque modes on page 250.

**Figure 11-7 Menu 4 Servo logic diagram**



\*For more information, refer to section 11.21.4 *Torque modes* on page 250.

| Parameter | Range(⇅)                          |        | Default(⇄)                       |                   |       | Type |  |      |  |    |     |    |    |    |
|-----------|-----------------------------------|--------|----------------------------------|-------------------|-------|------|--|------|--|----|-----|----|----|----|
|           | OL                                | CL     | OL                               | VT                | SV    |      |  |      |  |    |     |    |    |    |
| 4.01      | Current magnitude                 | {0.12} | 0 to DRIVE_CURRENT_MAX A         |                   |       |      |  |      |  | RO | Uni | FI | NC | PT |
| 4.02      | Active current                    | {0.13} | ±DRIVE_CURRENT_MAX A             |                   |       |      |  |      |  | RO | Bi  | FI | NC | PT |
| 4.03      | Torque demand                     |        | ±TORQUE_PROD_CURRENT_MAX %       |                   |       |      |  |      |  | RO | Bi  | FI | NC | PT |
| 4.04      | Current demand                    |        | ±TORQUE_PROD_CURRENT_MAX %       |                   |       |      |  |      |  | RO | Bi  | FI | NC | PT |
| 4.05      | Motoring current limit            |        | 0 to MOTOR1_CURRENT_LIMIT_MAX %  |                   | 165.0 |      | 175.0  |      |  | RW | Uni |    | RA | US |
| 4.06      | Regen current limit               |        | 0 to MOTOR1_CURRENT_LIMIT_MAX %  |                   | 165.0 |      | 175.0  |      |  | RW | Uni |    | RA | US |
| 4.07      | Symmetrical current limit         | {0.06} | 0 to MOTOR1_CURRENT_LIMIT_MAX %  |                   | 165.0 |      | 175.0  |      |  | RW | Uni |    | RA | US |
| 4.08      | Torque reference                  |        | ±USER_CURRENT_MAX %              |                   |       |      | 0.00   |      |  | RW | Bi  |    |    | US |
| 4.09      | Torque offset                     |        | ±USER_CURRENT_MAX %              |                   |       |      | 0.0  |      |  | RW | Bi  |    |    | US |
| 4.10      | Torque offset select              |        | OFF (0) or On (1)                |                   |       |      | OFF (0)  |      |  | RW | Bit |    |    | US |
| 4.11      | Torque mode selector              | {0.14} | 0 to 1                           | 0 to 4            |       |      | 0  |      |  | RW | Uni |    |    | US |
| 4.12      | Current demand filter 1           | {0.17} |                                  | 0.0 to 25.0 ms    |       |      | 0.0  |      |  | RW | Uni |    |    | US |
| 4.13      | Current controller Kp gain        | {0.38} | 0 to 30,000                      |                   | 20    |      | 200V drive: 75<br>400V drive: 150<br>575V drive: 180<br>690V drive: 215      |      |  | RW | Uni |    |    | US |
| 4.14      | Current controller Ki gain        | {0.39} | 0 to 30,000                      |                   | 40    |      | 200V drive: 1000<br>400V drive: 2000<br>575V drive: 2400<br>690V drive: 3000 |      |  | RW | Uni |    |    | US |
| 4.15      | Thermal time constant             | {0.45} | 0.0 to 3000.0                    |                   | 89.0  |      | 89.0   | 20.0 |  | RW | Uni |    |    | US |
| 4.16      | Thermal protection mode           |        | 0 to 1                           |                   |       |      | 0  |      |  | RW | Bit |    |    | US |
| 4.17      | Reactive current                  |        | ±DRIVE_CURRENT_MAX A             |                   |       |      |  |      |  | RO | Bi  | FI | NC | PT |
| 4.18      | Overriding current limit          |        | ±TORQUE_PROD_CURRENT_MAX %       |                   |       |      |  |      |  | RO | Uni |    | NC | PT |
| 4.19      | Overload accumulator              |        | 0 to 100.0 %                     |                   |       |      |  |      |  | RO | Uni |    | NC | PT |
| 4.20      | Percentage load                   |        | ±USER_CURRENT_MAX %              |                   |       |      |  |      |  | RO | Bi  | FI | NC | PT |
| 4.22      | Inertia compensation enable       |        |                                  | OFF (0) or On (1) |       |      | OFF (0)  |      |  | RW | Bit |    |    | US |
| 4.23      | Current demand filter 2           |        |                                  | 0.0 to 25.0 ms    |       |      | 0.0  |      |  | RW | Uni |    |    | US |
| 4.24      | User current maximum scaling      |        | 0.0 to TORQUE_PROD_CURRENT_MAX % |                   | 165.0 |      | 175.0  |      |  | RW | Uni |    | RA | US |
| 4.25      | Low speed thermal protection mode |        | OFF (0) or On (1)                |                   |       |      | OFF (0)  |      |  | RW | Bit |    |    | US |
| 4.26      | Percentage torque                 |        | ±USER_CURRENT_MAX %              |                   |       |      |  |      |  | RO | Bi  | FI | NC | PT |

|    |              |    |             |     |            |    |                  |     |               |     |             |    |                 |
|----|--------------|----|-------------|-----|------------|----|------------------|-----|---------------|-----|-------------|----|-----------------|
| RW | Read / Write | RO | Read only   | Uni | Unipolar   | Bi | Bi-polar         | Bit | Bit parameter | Txt | Text string |    |                 |
| FI | Filtered     | DE | Destination | NC  | Not cloned | RA | Rating dependent | PT  | Protected     | US  | User save   | PS | Power down save |

## 11.5 Menu 5: Motor control

Figure 11-8 Menu 5 Open-loop logic diagram

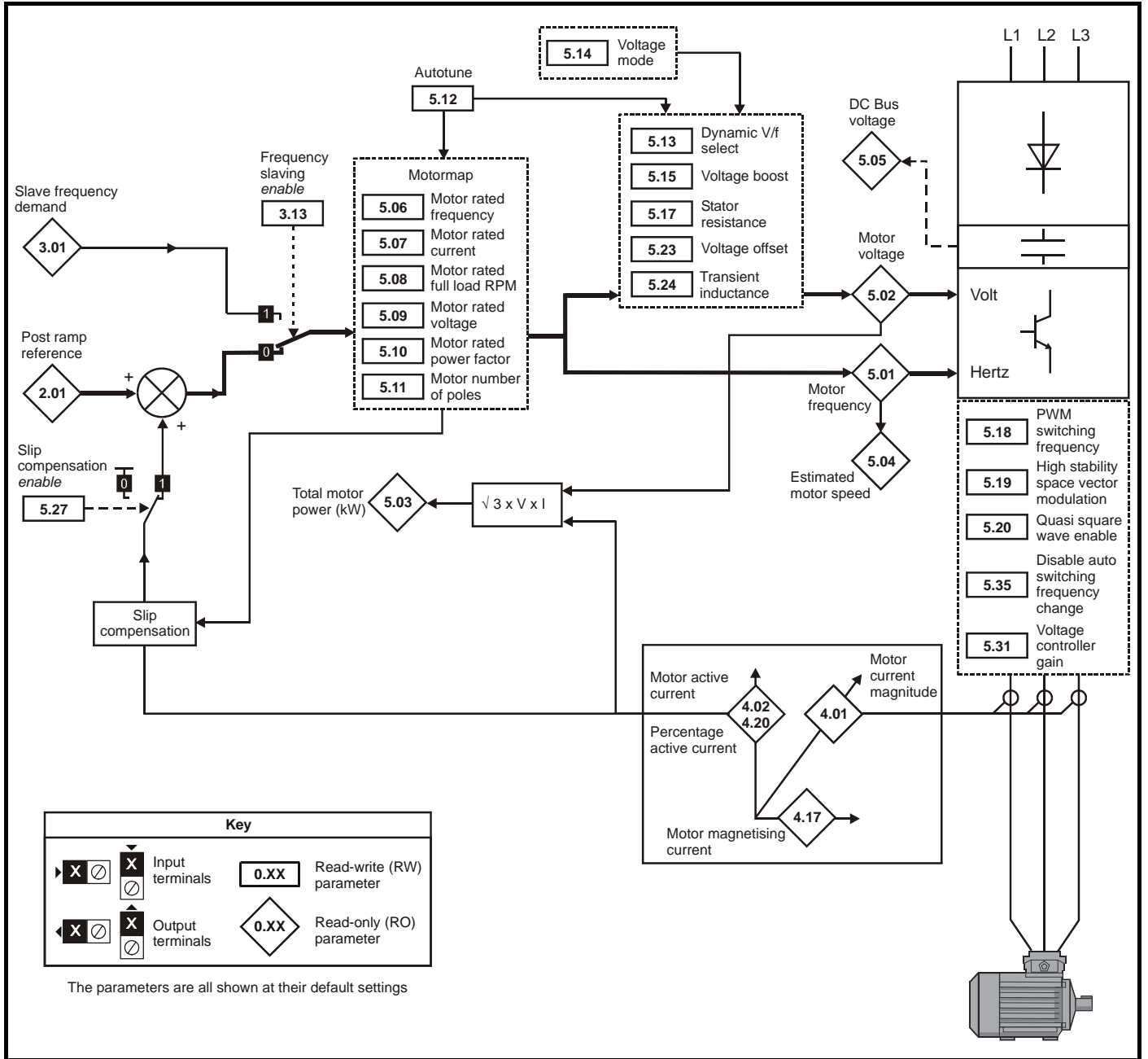
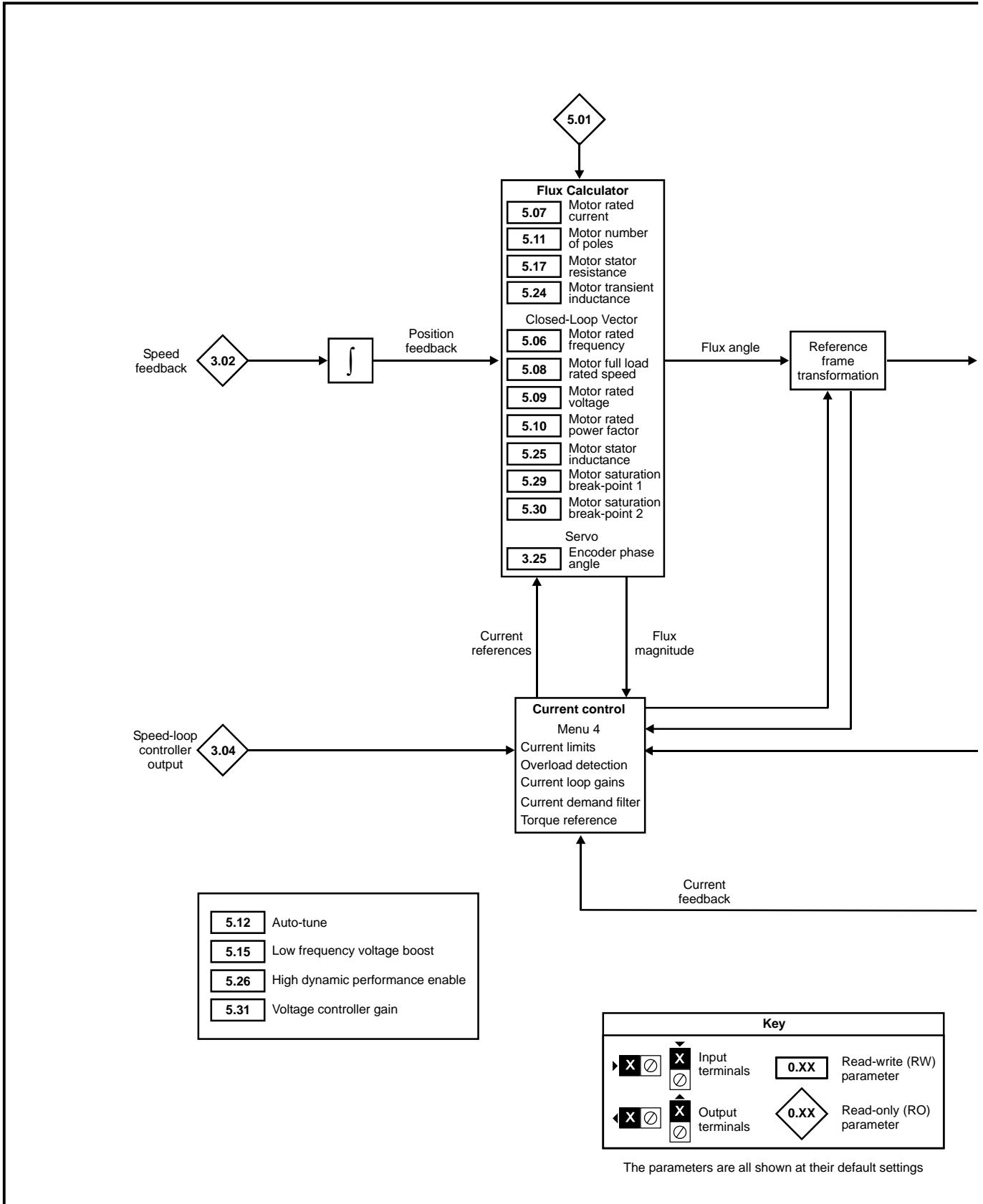
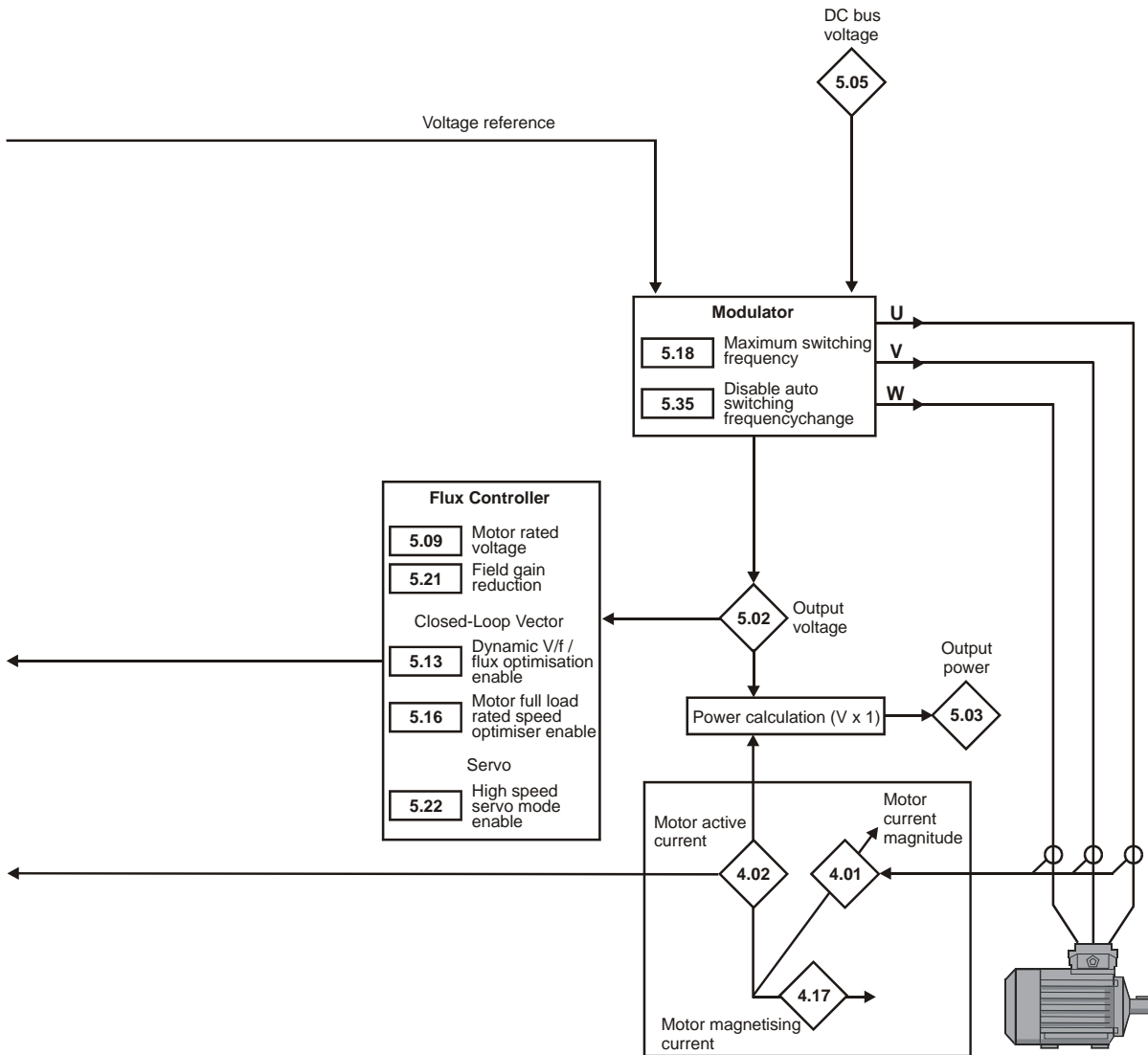




Figure 11-9 Menu 5 Closed-loop logic diagram



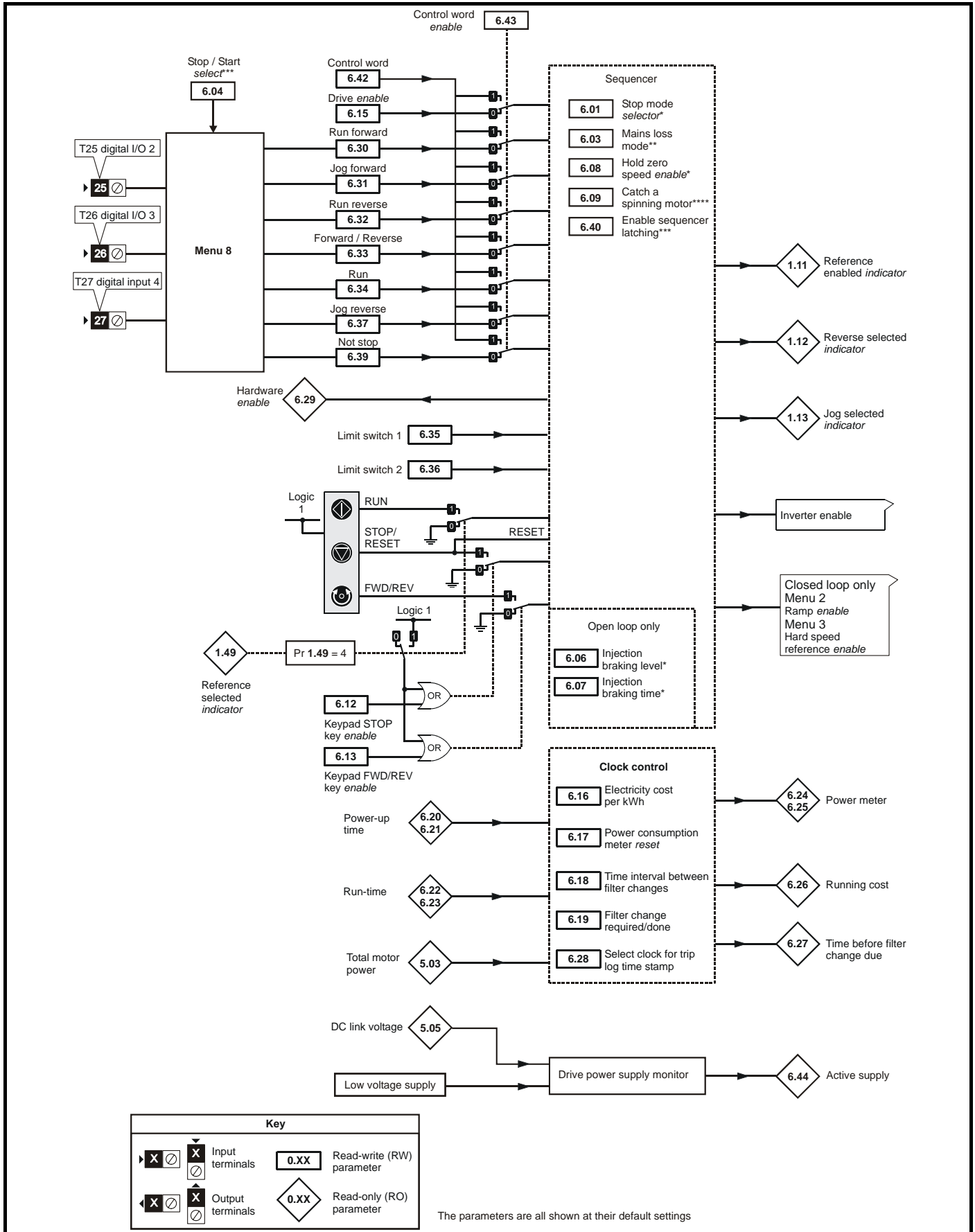


| Parameter |  | Range( $\hat{\uparrow}$ )  |  | Default( $\Rightarrow$ )  |                                |          | Type       |     |     |    |    |  |    |
|-----------|--|--|--|---|--------------------------------|----------|------------|-----|-----|----|----|--|----|
|           |  | OL   | CL                                       | OL  | VT                             | SV       | RO         | Bi  | FI  | NC | PT |  |    |
| 5.01      | Output frequency {0.11}                    | $\pm$ SPEED_FREQ_ MAX Hz   |  | $\pm$ 1,250.0 Hz  |                                |          | RO         | Bi  | FI  | NC | PT |  |    |
| 5.02      | Output voltage                             | 0 to AC_voltage_max V  |  |   |                                |          | RO         | Uni | FI  | NC | PT |  |    |
| 5.03      | Output power                               | $\pm$ Power_max kW   |  |   |                                |          | RO         | Bi  | FI  | NC | PT |  |    |
| 5.04      | Motor rpm {0.10}                           | $\pm$ 180,000 rpm  |  |   |                                |          | RO         | Bi  | FI  | NC | PT |  |    |
| 5.05      | D.C bus voltage                            | 0 to +DC_voltage_max V   |  |   |                                |          | RO         | Uni | FI  | NC | PT |  |    |
| 5.06      | Rated frequency {0.47}                     | 0 to 3,000 Hz  | VT> 0 to 1,250.0 Hz                      | EUR> 50.0, USA> 60.0  |                                |          | RW         | Uni |     |    |    |  | US |
| 5.07      | Motor rated current {0.46}                 | 0 to Rated_current_max A   |  | Drive rated current [11.32]   |                                |          | RW         | Uni |     | RA |    |  | US |
| 5.08      | Rated load rpm / rated speed {0.45}        | 0 to 180,000 rpm   | 0.00 to 40,000.00 rpm                    | EUR> 1,500<br>USA> 1,800  | EUR> 1,450.00<br>USA> 1,770.00 | 3,000.00 | RW         | Uni |     |    |    |  | US |
| 5.09      | Rated voltage {0.44}                       | 0 to AC_VOLTAGE_SET_MAX V  |  | 200V drive: 230<br>400V drive: EUR> 400<br>USA> 460<br>575V drive: 575<br>690V drive: 690 |                                |          | RW         | Uni |     | RA |    |  | US |
| 5.10      | Rated power factor {0.43}                  | OL & VT> 0.000 to 1.000  |  | 0.850   |                                |          | RW         | Uni |     | RA |    |  | US |
| 5.11      | Number of motor poles {0.42}               | Auto to 120 Pole (0 to 60)   |  | Auto (0)  |                                |          | 6 POLE (3) | RW  | Txt |    |    |  | US |
| 5.12      | Autotune {0.40}                            | 0 to 2   | VT> 0 to 4<br>SV> 0 to 6                 | 0   |                                |          | RW         | Uni |     | NC |    |  |    |
| 5.13      | Dynamic V/F / flux optimise select {0.09}  | OFF (0) or On (1)  | VT> OFF (0) or On (1)                    | OFF (0)   |                                |          | RW         | Bit |     |    |    |  | US |
| 5.14      | Voltage mode select {0.07}                 | Ur_S (0), Ur (1),<br>Fd (2), Ur_Auto (3),<br>Ur_I (4), SrE (5)                   |  | Ur_I (4)  |                                |          | RW         | Txt |     |    |    |  | US |
|           | Action on enable                           |  | SV> nonE (0),<br>Ph EnL (1), Ph Init (2) |   |                                | nonE(0)  | RW         | Txt |     |    |    |  | US |
| 5.15      | Low frequency voltage boost {0.08}         | 0.0 to 25.0 % of motor rated voltage   |  | 3.0   | 1.0                            |          | RW         | Uni |     |    |    |  | US |
| 5.16      | Rated rpm autotune {0.33}                  |  | VT> 0 to 2                               | 0   |                                |          | RW         | Uni |     |    |    |  | US |
| 5.17      | Stator resistance                          | Size 1 to 5: 0.000 to 65.000 $\Omega$<br>Size 6: 0.000 to 65.000 x 10 m $\Omega$ |  | 0.0   |                                |          | RW         | Uni |     | RA |    |  | US |
| 5.18      | Maximum switching frequency {0.41}         | 3 (0), 4 (1), 6 (2), 8 (3), 12 (4), 16 (5) kHz                                   |  | 3 (0)   |                                |          | 6 (2)      | RW  | Txt |    | RA |  | US |
| 5.19      | High stability space vector modulation     | OFF (0) or On (1)  |  | OFF (0)   |                                |          | RW         | Bit |     |    |    |  | US |
| 5.20      | Quasi-square enable                        | OFF (0) or On (1)  |  | OFF (0)   |                                |          | RW         | Bit |     |    |    |  | US |
| 5.21      | Field gain reduction                       |  |  | OFF (0)   |                                |          | RW         | Bit |     |    |    |  | US |
| 5.22      | High speed servo mode enable               |  |  | SV> OFF (0) or On (1)   |                                |          | 0          | RW  | Bit |    |    |  | US |
| 5.23      | Voltage offset                             | 0.0 to 25.0 V  |  | 0.0   |                                |          | RW         | Uni |     | RA |    |  | US |
| 5.24      | Transient inductance ( $\sigma_{L_s}$ )    | 0.000 to 500.000 mH  |  | 0.000   |                                |          | RW         | Uni |     | RA |    |  | US |
| 5.25      | Stator inductance ( $L_s$ )                |  |  | VT> 0.00 to 5,000.00 mH   | 0.00                           |          | RW         | Uni |     | RA |    |  | US |
| 5.26      | High dynamic performance enable            |  |  | OFF (0) or On (1)   |                                |          | OFF (0)    | RW  | Bit |    |    |  | US |
| 5.27      | Enable slip compensation                   | OFF (0) or On (1)  |  | On (1)  |                                |          | RW         | Bit |     |    |    |  | US |
| 5.28      | Field weakening compensation disable       |  |  | VT> OFF (0) or On (1)   |                                |          | OFF (0)    | RW  | Bit |    |    |  | US |
| 5.29      | Motor saturation breakpoint 1              |  |  | VT> 0 to 100% of rated flux   |                                |          | 50         | RW  | Uni |    |    |  | US |
| 5.30      | Motor saturation breakpoint 2              |  |  | VT> 0 to 100% of rated flux   |                                |          | 75         | RW  | Uni |    |    |  | US |
| 5.31      | Voltage controller gain                    | 0 to 30  |  | 1   |                                |          | RW         | Uni |     |    |    |  | US |
| 5.32      | Motor torque per amp, $K_t$                |  |  | VT> 0.00 to 500.00 N m A <sup>-1</sup>  |                                |          | RO         | Uni |     |    |    |  | US |
|           |  |  |  | SV> 0.00 to 500.00 N m A <sup>-1</sup>  | 1.60                           |          | RW         | Uni |     |    |    |  | US |
| 5.33      | Motor volts per 1,000 rpm, $K_e$           |  |  | SV> 0 to 10,000 V   |                                |          | 98         | RW  | Uni |    |    |  | US |
| 5.35      | Disable auto switching frequency change    | OFF (0) or On (1)  |  | OFF (0)   |                                |          | RW         | Bit |     |    |    |  | US |
| 5.36      | Motor pole pitch                           | 0 to 655.35 mm   |  | 0.00  |                                |          | RW         | Uni |     |    |    |  | US |
| 5.37      | Actual switching frequency                 | 3 (0), 4 (1), 6 (2), 8 (3), 12 (4), 16 (5), 6 rEd (6), 12 rEd (7)                |  |   |                                |          | RO         | Txt |     | NC | PT |  |    |
| 5.38      | Minimal movement phasing test angle        |  |  | SV> 0.0 to 25.5°  |                                |          | 5.0        | RW  | Uni |    |    |  | US |
| 5.39      | Minimal movement phasing test pulse length |  |  | SV> 0 to 3  |                                |          | 0          | RW  | Uni |    |    |  | US |
| 5.40      | Spin start boost                           | 0.0 to 10.0  |  | VT> 0.0 to 10.0   |                                |          | 1.0        | RW  | Uni |    |    |  | US |

|    |              |    |             |     |            |    |                  |     |               |     |             |    |                 |
|----|--------------|----|-------------|-----|------------|----|------------------|-----|---------------|-----|-------------|----|-----------------|
| RW | Read / Write | RO | Read only   | Uni | Unipolar   | Bi | Bi-polar         | Bit | Bit parameter | Txt | Text string |    |                 |
| FI | Filtered     | DE | Destination | NC  | Not cloned | RA | Rating dependent | PT  | Protected     | US  | User save   | PS | Power down save |

## 11.6 Menu 6: Sequencer and clock

Figure 11-10 Menu 6 logic diagram



| Parameter |  | Range( $\hat{\uparrow}$ )                                       |    | Default( $\Rightarrow$ )   |    |        | Type |           |    |     |     |     |    |    |    |
|-----------|--|---|----|--|----|--------|------|-----------|----|-----|-----|-----|----|----|----|
|           |  | OL  | CL | OL   | VT | SV     | RW   | Txt       |    |     | US  |     |    |    |    |
| 6.01      | Stop mode  | COASt (0), rP (1), rP.dcl (2), dcl (3), td.dcl (4), dISABLe (5) |    | COASt (0), rP (1), no.rP (2)                                       |    | rP (1) |      | no.rP (2) |    |     | RW  | Txt |    |    | US |
| 6.03      | Mains loss mode  | diS (0), StoP (1), ridE.th (2)                                  |    | diS (0)  |    |        | RW   | Txt       |    |     |     |     |    | US |    |
| 6.04      | Start / stop logic select                                | 0 to 4  |    | 4  |    |        | RW   | Uni       |    |     |     |     |    | US |    |
| 6.06      | Injection braking level                                  | 0 to 150.0%   |    | 100.0%   |    |        | RW   | Uni       |    | RA  |     |     |    | US |    |
| 6.07      | Injection braking time                                   | 0.0 to 25.0s  |    | 1.0  |    |        | RW   | Uni       |    |     |     |     |    | US |    |
| 6.08      | Hold zero speed  | OFF (0) or On (1)   |    | OFF (0)  |    | On (1) |      |           | RW | Bit |     |     |    | US |    |
| 6.09      | Catch a spinning motor {0.33}                            | 0 to 3  |    | 0  |    |        | 1    |           |    | RW  | Uni |     |    | US |    |
| 6.12      | Enable stop key  | OFF (0) or On (1)   |    | OFF (0)  |    |        | RW   | Bit       |    |     |     |     |    | US |    |
| 6.13      | Enable forward / reverse key {0.28}                      | OFF (0) or On (1)   |    | OFF (0)  |    |        | RW   | Bit       |    |     |     |     |    | US |    |
| 6.15      | Drive enable   | OFF (0) or On (1)   |    | On (1)   |    |        | RW   | Bit       |    |     |     |     |    | US |    |
| 6.16      | Electricity cost per kWh                                 | 0.0 to 600.0 currency units per kWh                             |    | 0  |    |        | RW   | Uni       |    |     |     |     |    | US |    |
| 6.17      | Reset energy meter                                       | OFF (0) or On (1)   |    | OFF (0)  |    |        | RW   | Bit       |    | NC  |     |     |    |    |    |
| 6.18      | Time between filter changes                              | 0 to 30,000 hrs   |    | 0  |    |        | RW   | Uni       |    |     |     |     |    | US |    |
| 6.19      | Filter change required / change done                     | OFF (0) or On (1)   |    | OFF (0)  |    |        | RW   | Bit       |    |     |     |     | PT |    |    |
| 6.20      | Powered-up time: years.days                              | 0 to 9.364 years.days   |    |  |    |        | RW   | Uni       |    | NC  | PT  |     |    |    |    |
| 6.21      | Powered-up time: hours.minutes                           | 0 to 23.59 hours.minutes  |    |  |    |        | RW   | Uni       |    | NC  | PT  |     |    |    |    |
| 6.22      | Run time: years.days                                     | 0 to 9.364 years.days   |    |  |    |        | RO   | Uni       |    | NC  | PT  | PS  |    |    |    |
| 6.23      | Run time: hours.minutes                                  | 0 to 23.59 hours.minutes  |    |  |    |        | RO   | Uni       |    | NC  | PT  | PS  |    |    |    |
| 6.24      | Energy meter: MWh  | $\pm$ 999.9 MWh   |    |  |    |        | RO   | Bi        |    | NC  | PT  | PS  |    |    |    |
| 6.25      | Energy meter: kWh  | $\pm$ 99.99 kWh   |    |  |    |        | RO   | Bi        |    | NC  | PT  | PS  |    |    |    |
| 6.26      | Running cost   | $\pm$ 32,000  |    |  |    |        | RO   | Bi        |    | NC  | PT  | PS  |    |    |    |
| 6.27      | Time before filter change due                            | 0 to 30,000 hrs   |    |  |    |        | RO   | Uni       |    | NC  | PT  | PS  |    |    |    |
| 6.28      | Select clock for trip log time sampling                  | OFF (0) or On (1)   |    | OFF (0)  |    |        | RW   | Bit       |    |     |     |     |    | US |    |
| 6.29      | Hardware enable  | OFF (0) or On (1)   |    |  |    |        | RO   | Bit       |    | NC  | PT  |     |    |    |    |
| 6.30      | Sequencing bit: Run forward                              | OFF (0) or On (1)   |    | OFF (0)  |    |        | RW   | Bit       |    | NC  |     |     |    |    |    |
| 6.31      | Sequencing bit: Jog forward                              | OFF (0) or On (1)   |    | OFF (0)  |    |        | RW   | Bit       |    | NC  |     |     |    |    |    |
| 6.32      | Sequencing bit: Run reverse                              | OFF (0) or On (1)   |    | OFF (0)  |    |        | RW   | Bit       |    | NC  |     |     |    |    |    |
| 6.33      | Sequencing bit: Forward / reverse                        | OFF (0) or On (1)   |    | OFF (0)  |    |        | RW   | Bit       |    | NC  |     |     |    |    |    |
| 6.34      | Sequencing bit: Run                                      | OFF (0) or On (1)   |    | OFF (0)  |    |        | RW   | Bit       |    | NC  |     |     |    |    |    |
| 6.35      | Forward limit switch                                     | OFF (0) or On (1)   |    | OFF (0)  |    |        | RW   | Bit       |    | NC  |     |     |    |    |    |
| 6.36      | Reverse limit switch                                     | OFF (0) or On (1)   |    | OFF (0)  |    |        | RW   | Bit       |    | NC  |     |     |    |    |    |
| 6.37      | Sequencing bit: Jog reverse                              | OFF (0) or On (1)   |    | OFF (0)  |    |        | RW   | Bit       |    | NC  |     |     |    |    |    |
| 6.39      | Sequencing bit: Not stop                                 | OFF (0) or On (1)   |    | OFF (0)  |    |        | RW   | Bit       |    | NC  |     |     |    |    |    |
| 6.40      | Enable sequencer latching                                | OFF (0) or On (1)   |    | OFF (0)  |    |        | RW   | Bit       |    |     |     |     |    | US |    |
| 6.41      | Drive event flags  | 0 to 65,535   |    | 0  |    |        | RW   | Uni       |    | NC  |     |     |    |    |    |
| 6.42      | Control word   | 0 to 32,767   |    | 0  |    |        | RW   | Uni       |    | NC  |     |     |    |    |    |
| 6.43      | Control word enable                                      | OFF (0) or On (1)   |    | OFF (0)  |    |        | RW   | Bit       |    |     |     |     |    | US |    |
| 6.44      | Active supply  | OFF (0) or On (1)   |    |  |    |        | RO   | Bit       |    | NC  | PT  |     |    |    |    |
| 6.45      | Force cooling fan to run at full speed                   | OFF (0) or On (1)   |    | OFF (0)  |    |        | RW   | Bit       |    |     |     |     |    | US |    |
| 6.46      | Normal low voltage supply                                | Size 1: 48V, Size 2 and 3: 48V to 72V                           |    | 48   |    |        | RW   | Uni       |    |     |     | PT  | US |    |    |
| 6.47      | Disable mains/phase loss detection from input rectifier  | OFF (0) or On (1)   |    | OFF (0)  |    |        | RW   | Bit       |    |     |     |     |    | US |    |
| 6.48      | Mains loss ride through detection level                  | 0 to DC_VOLTAGE_SET_MAX V                                       |    | 200V drive: 205, 400V drive: 410, 575V drive: 540, 690V drive: 540 |    |        | RW   | Uni       |    | RA  |     |     |    | US |    |
| 6.49      | Disable multi-module drive module number storing on trip | OFF (0) or On (1)   |    | OFF (0)  |    |        | RW   | Bit       |    |     |     |     |    | US |    |
| 6.50      | Drive comms state  | drv (0), SLot 1(1), SSlot 2 (2), SSlot 3 (3)                    |    |  |    |        | RO   | Txt       |    | NC  | PT  |     |    |    |    |
| 6.51      | External rectifier not active                            | OFF (0) or On (1)   |    | OFF (0)  |    |        | RW   | Bit       |    |     |     |     |    |    |    |

|    |              |    |             |     |            |    |                  |     |               |     |             |    |                 |
|----|--------------|----|-------------|-----|------------|----|------------------|-----|---------------|-----|-------------|----|-----------------|
| RW | Read / Write | RO | Read only   | Uni | Unipolar   | Bi | Bi-polar         | Bit | Bit parameter | Txt | Text string |    |                 |
| FI | Filtered     | DE | Destination | NC  | Not cloned | RA | Rating dependent | PT  | Protected     | US  | User save   | PS | Power down save |

\*For more information, refer to section 11.21.5 *Stop modes* on page 251.

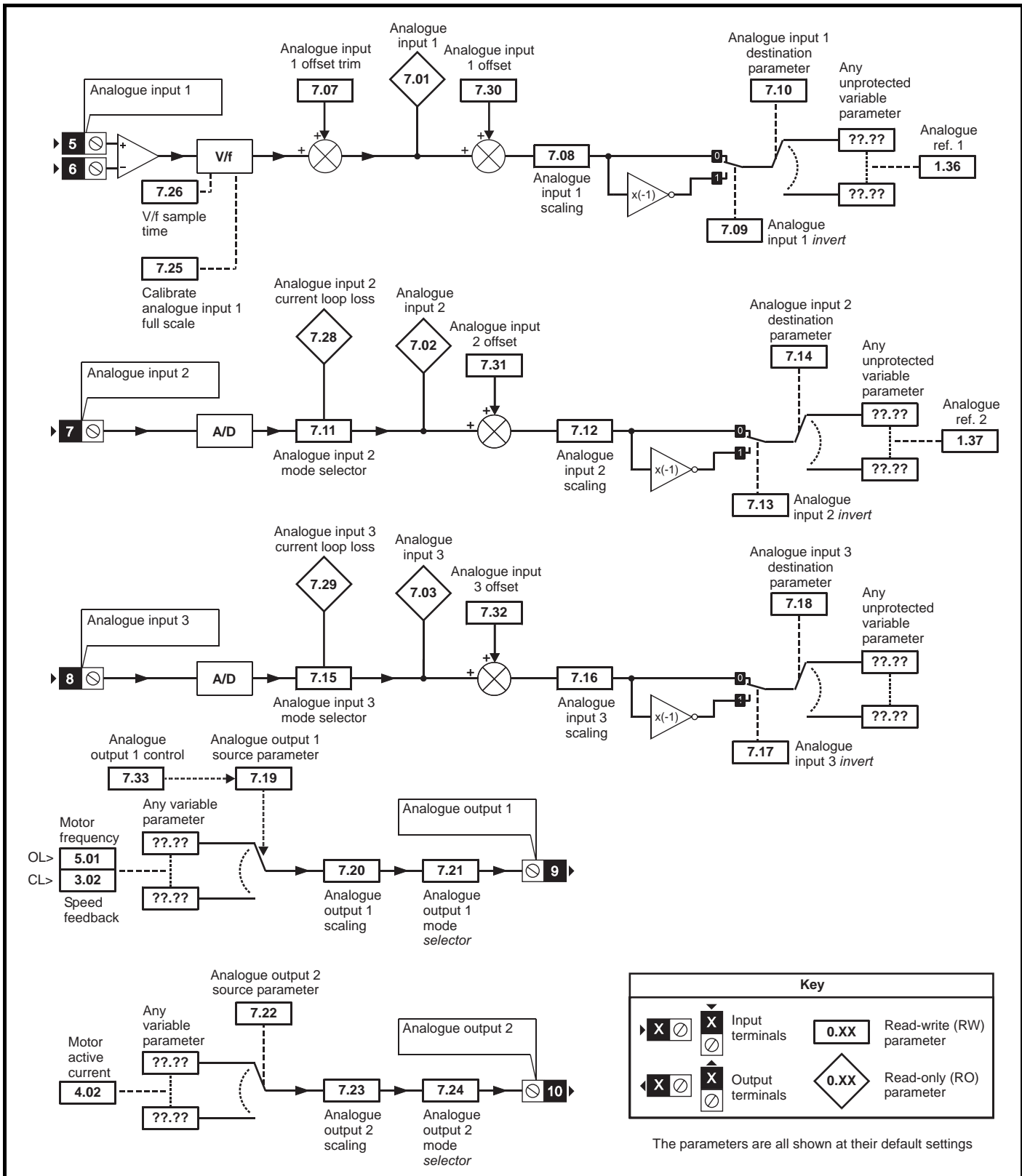
\*\*For more information, refer to section 11.21.6 *Mains loss modes* on page 252.

\*\*\*For more information, refer to section 11.21.7 *Start / stop logic modes* on page 253.

\*\*\*\*For more information, refer to section 11.21.8 *Catch a spinning motor* on page 254.

## 11.7 Menu 7: Analogue I/O

Figure 11-11 Menu 7 logic diagram



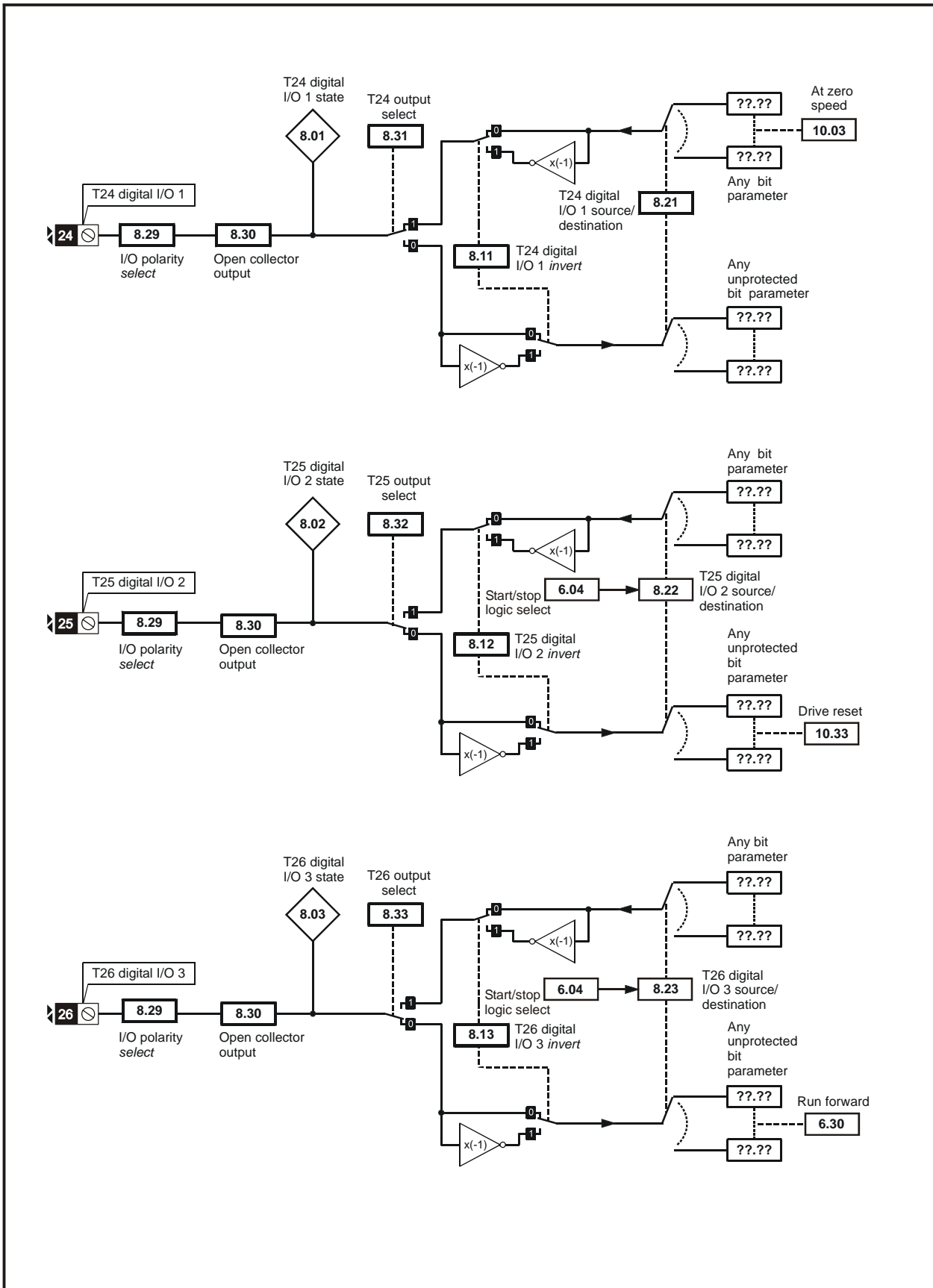
| Parameter | Range(⇅)                                   |   | Default(⇨) |          |    | Type |     |    |    |       |
|-----------|--|---|------------|----------|----|------|-----|----|----|-------|
|           | OL   | CL  | OL         | VT       | SV |      |     |    |    |       |
| 7.01      | T5/6 analogue input 1 level                | ±100.00 %   |            |          |    | RO   | Bi  | NC | PT |       |
| 7.02      | T7 analogue input 2 level                  | ±100.0 %  |            |          |    | RO   | Bi  | NC | PT |       |
| 7.03      | T8 analogue input 3 level                  | ±100.0 %  |            |          |    | RO   | Bi  | NC | PT |       |
| 7.04      | Power circuit temperature 1                | -128 to 127 °C  |            |          |    | RO   | Bi  | NC | PT |       |
| 7.05      | Power circuit temperature 2                | -128 to 127 °C  |            |          |    | RO   | Bi  | NC | PT |       |
| 7.06      | Control board temperature                  | -128 to 127 °C  |            |          |    | RO   | Bi  | NC | PT |       |
| 7.07      | T5/6 analogue input 1 offset trim {0.13}   | ±10.000 %   |            | 0.000    |    | RW   | Bi  |    |    | US    |
| 7.08      | T5/6 analogue input 1 scaling              | 0 to 4.000  |            | 1.000    |    | RW   | Uni |    |    | US    |
| 7.09      | T5/6 analogue input 1 invert               | OFF (0) or On (1)   |            | OFF (0)  |    | RW   | Bit |    |    | US    |
| 7.10      | T5/6 analogue input 1 destination          | Pr 0.00 to 21.51  |            | Pr 1.36  |    | RW   | Uni | DE |    | PT US |
| 7.11      | T7 analogue input 2 mode {0.19}            | 0-20 (0), 20-0 (1), 4-20.tr (2), 20-4.tr (3), 4-20 (4), 20-4 (5), VOLt (6)                                  |            | VOLt (6) |    | RW   | Txt |    |    | US    |
| 7.12      | T7 analogue input 2 scaling                | 0 to 4.000  |            | 1.000    |    | RW   | Uni |    |    | US    |
| 7.13      | T7 analogue input 2 invert                 | OFF (0) or On (1)   |            | OFF (0)  |    | RW   | Bit |    |    | US    |
| 7.14      | T7 analogue input 2 destination {0.20}     | Pr 0.00 to 21.51  |            | Pr 1.37  |    | RW   | Uni | DE |    | PT US |
| 7.15      | T8 analogue input 3 mode {0.21}            | 0-20 (0), 20-0 (1), 4-20.tr (2), 20-4.tr (3), 4-20 (4), 20-4 (5), VOLt (6), th.SC (7), the (8), th.diSP (9) |            | VOLt (6) |    | RW   | Txt |    |    | US    |
| 7.16      | T8 analogue input 3 scaling                | 0 to 4.000  |            | 1.000    |    | RW   | Uni |    |    | US    |
| 7.17      | T8 analogue input 3 invert                 | OFF (0) or On (1)   |            | OFF (0)  |    | RW   | Bit |    |    | US    |
| 7.18      | T8 analogue input 3 destination            | Pr 0.00 to 21.51  |            | Pr 0.00  |    | RW   | Uni | DE |    | PT US |
| 7.19      | T9 analogue output 1 source                | Pr 0.00 to 21.51  | Pr 5.01    | Pr 3.02  |    | RW   | Uni |    |    | PT US |
| 7.20      | T9 analogue output 1 scaling               | 0.000 to 4.000  |            | 1.000    |    | RW   | Uni |    |    | US    |
| 7.21      | T9 analogue output 1 mode                  | VOLt (0), 0-20 (1), 4-20 (2), H.SPd (3)   |            | VOLt (0) |    | RW   | Txt |    |    | US    |
| 7.22      | T10 analogue output 2 source               | Pr 0.00 to 21.51  |            | Pr 4.02  |    | RW   | Uni |    |    | PT US |
| 7.23      | T10 analogue output 2 scaling              | 0.000 to 4.000  |            | 1.000    |    | RW   | Uni |    |    | US    |
| 7.24      | T10 analogue output 2 mode                 | VOLt (0), 0-20 (1), 4-20 (2), H.SPd (3)   |            | VOLt (0) |    | RW   | Txt |    |    | US    |
| 7.25      | Calibrate T5/6 analogue input 1 full scale | OFF (0) or On (1)   |            | OFF (0)  |    | RW   | Bit | NC |    |       |
| 7.26      | T5/6 analogue input 1 sample time          | 0 to 8.0 ms   |            | 4.0      |    | RW   | Uni |    |    | US    |
| 7.28      | T7 analogue input 2 current loop loss      | OFF (0) or On (1)   |            |          |    | RO   | Bit | NC | PT |       |
| 7.29      | T8 analogue input 3 current loop loss      | OFF (0) or On (1)   |            |          |    | RO   | Bit | NC | PT |       |
| 7.30      | T5/6 analogue input 1 offset               | ±100.00 %   |            | 0.00     |    | RW   | Bi  |    |    | US    |
| 7.31      | T7 analogue input 2 offset                 | ±100.0 %  |            | 0.0      |    | RW   | Bi  |    |    | US    |
| 7.32      | T8 analogue input 3 offset                 | ±100.0 %  |            | 0.0      |    | RW   | Bi  |    |    | US    |
| 7.33      | T9 analogue output 1 control               | Fr (0), Ld (1), Adv (2)   |            | Adv (2)  |    | RW   | Txt |    |    | US    |
| 7.34      | IGBT junction temperature                  | ±200 °C   |            |          |    | RO   | Bi  | NC | PT |       |
| 7.35      | Drive thermal protection accumulator       | 0 to 100.0 %  |            |          |    | RO   | Uni | NC | PT |       |
| 7.36      | Power circuit temperature 3                | -128 to 127 °C  |            |          |    | RO   | Bi  | NC | PT |       |

|    |              |    |             |     |            |    |                  |     |               |     |             |    |                 |
|----|--------------|----|-------------|-----|------------|----|------------------|-----|---------------|-----|-------------|----|-----------------|
| RW | Read / Write | RO | Read only   | Uni | Unipolar   | Bi | Bi-polar         | Bit | Bit parameter | Txt | Text string |    |                 |
| FI | Filtered     | DE | Destination | NC  | Not cloned | RA | Rating dependent | PT  | Protected     | US  | User save   | PS | Power down save |

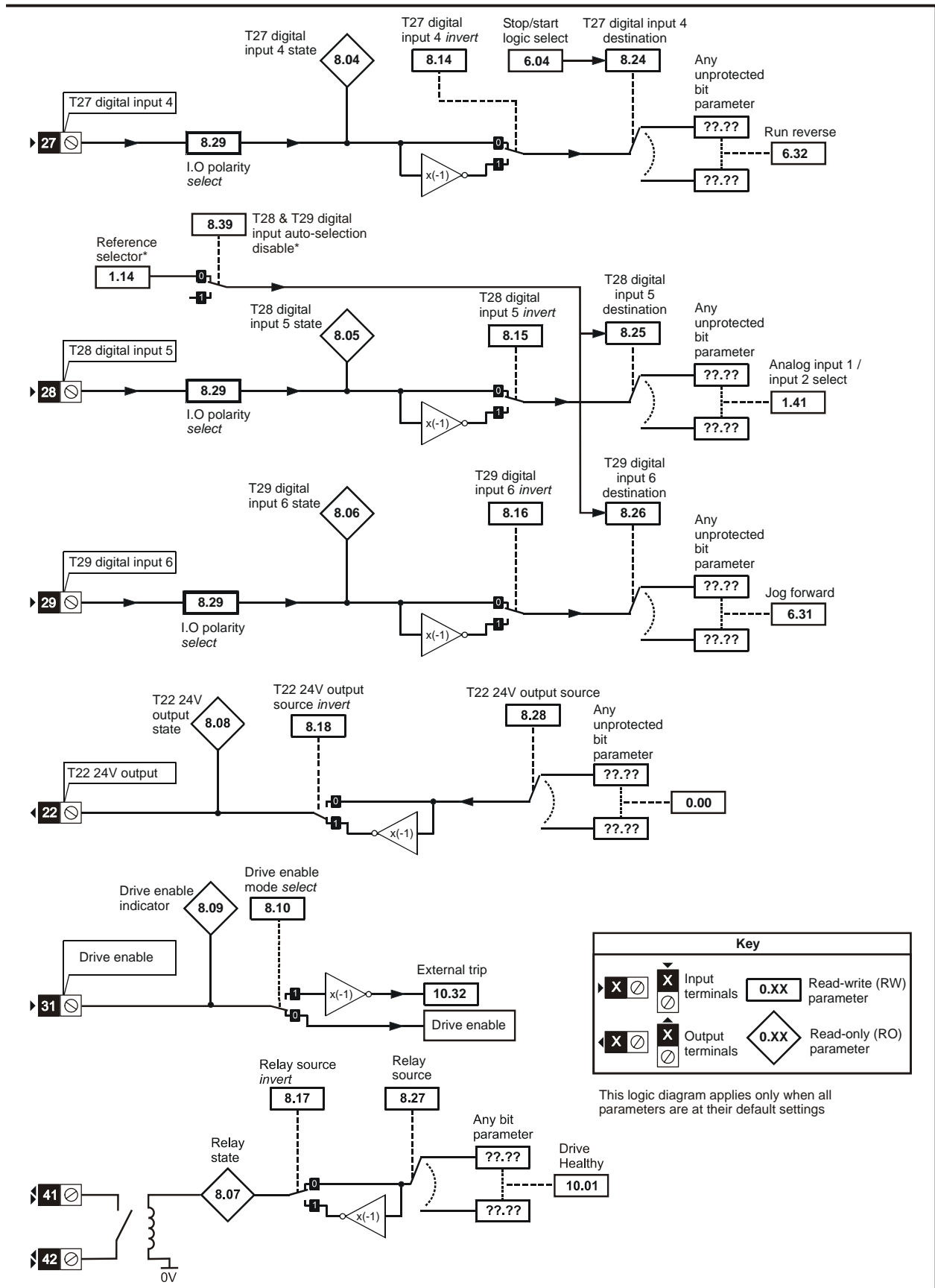


## 11.8 Menu 8: Digital I/O

Figure 11-12 Menu 8 logic diagram



\*For more information, please refer to 11.21.1 Reference modes on page 248.



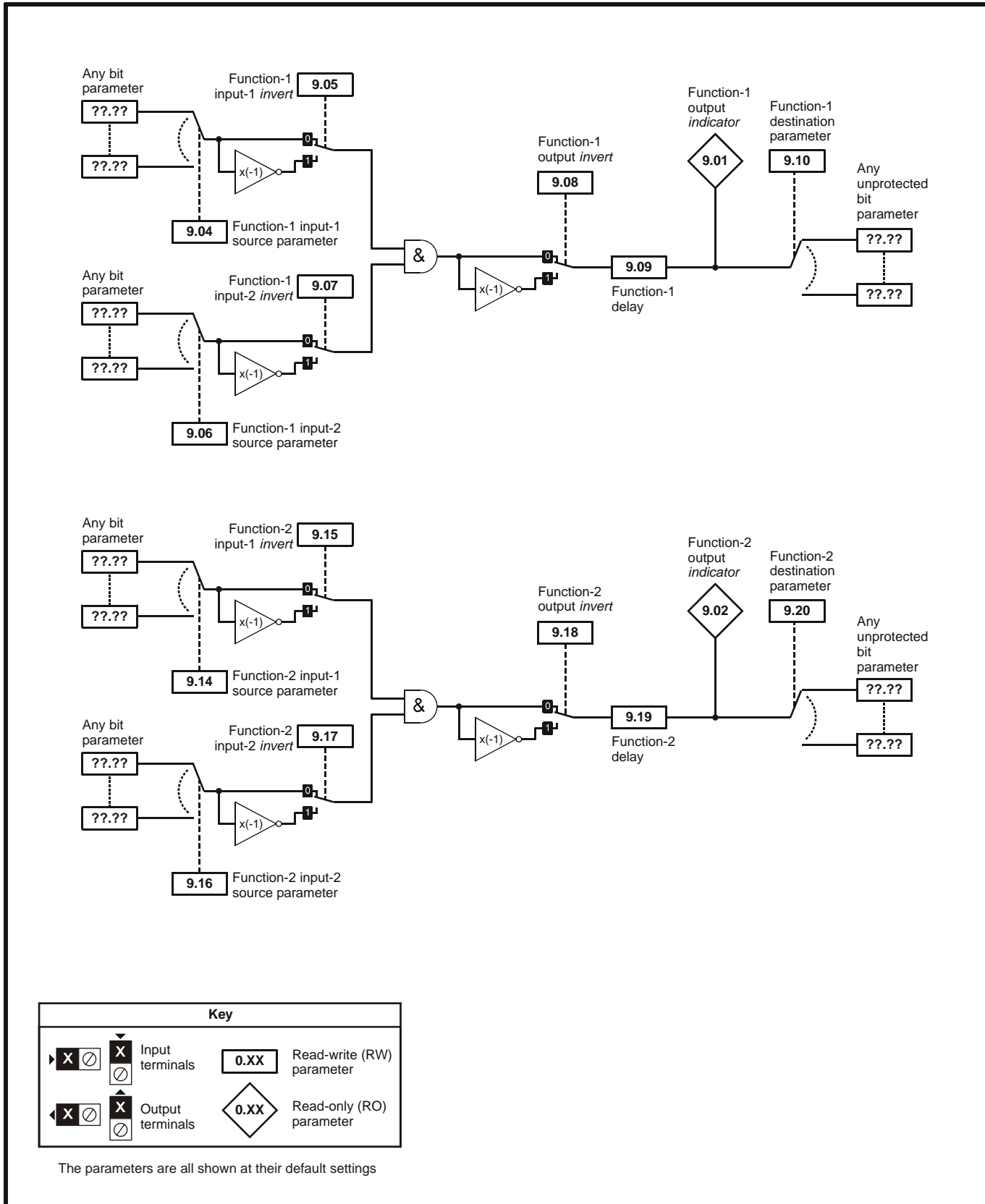
| Parameter | Range(⇅)  |                   | Default(⇒) |    |          | Type |     |    |    |    |  |    |
|-----------|---|-------------------|------------|----|----------|------|-----|----|----|----|--|----|
|           | OL  | CL                | OL         | VT | SV       |      |     |    |    |    |  |    |
| 8.01      | T24 digital I/O 1 state                               | OFF (0) or On (1) |            |    |          | RO   | Bit |    | NC | PT |  |    |
| 8.02      | T25 digital I/O 2 state                               | OFF (0) or On (1) |            |    |          | RO   | Bit |    | NC | PT |  |    |
| 8.03      | T26 digital I/O 3 state                               | OFF (0) or On (1) |            |    |          | RO   | Bit |    | NC | PT |  |    |
| 8.04      | T27 digital input 4 state                             | OFF (0) or On (1) |            |    |          | RO   | Bit |    | NC | PT |  |    |
| 8.05      | T28 digital input 5 state                             | OFF (0) or On (1) |            |    |          | RO   | Bit |    | NC | PT |  |    |
| 8.06      | T29 digital input 6 state                             | OFF (0) or On (1) |            |    |          | RO   | Bit |    | NC | PT |  |    |
| 8.07      | Relay state   | OFF (0) or On (1) |            |    |          | RO   | Bit |    | NC | PT |  |    |
| 8.08      | T22 24V output state                                  | OFF (0) or On (1) |            |    |          | RO   | Bit |    | NC | PT |  |    |
| 8.09      | Drive enable indicator                                | OFF (0) or On (1) |            |    |          | RO   | Bit |    | NC | PT |  |    |
| 8.10      | Drive enable mode select                              | OFF (0) or On (1) |            |    | OFF (0)  | RW   | Bit |    |    |    |  | US |
| 8.11      | T24 digital I/O 1 invert                              | OFF (0) or On (1) |            |    | OFF (0)  | RW   | Bit |    |    |    |  | US |
| 8.12      | T25 digital I/O 2 invert                              | OFF (0) or On (1) |            |    | OFF (0)  | RW   | Bit |    |    |    |  | US |
| 8.13      | T26 digital I/O 3 invert                              | OFF (0) or On (1) |            |    | OFF (0)  | RW   | Bit |    |    |    |  | US |
| 8.14      | T27 digital input 4 invert                            | OFF (0) or On (1) |            |    | OFF (0)  | RW   | Bit |    |    |    |  | US |
| 8.15      | T28 digital input 5 invert                            | OFF (0) or On (1) |            |    | OFF (0)  | RW   | Bit |    |    |    |  | US |
| 8.16      | T29 digital input 6 invert                            | OFF (0) or On (1) |            |    | OFF (0)  | RW   | Bit |    |    |    |  | US |
| 8.17      | Relay source invert                                   | OFF (0) or On (1) |            |    | OFF (0)  | RW   | Bit |    |    |    |  | US |
| 8.18      | T22 24V output source invert                          | OFF (0) or On (1) |            |    | On (1)   | RW   | Bit |    |    |    |  | US |
| 8.20      | Digital I/O read word                                 | 0 to 511          |            |    |          | RO   | Uni |    | NC | PT |  |    |
| 8.21      | T24 digital I/O 1 source/destination                  | Pr 0.00 to 21.51  |            |    | Pr 10.03 | RW   | Uni | DE |    | PT |  | US |
| 8.22      | T25 digital I/O 2 source/destination                  | Pr 0.00 to 21.51  |            |    | Pr 10.33 | RW   | Uni | DE |    | PT |  | US |
| 8.23      | T26 digital I/O 3 source/destination                  | Pr 0.00 to 21.51  |            |    | Pr 6.30  | RW   | Uni | DE |    | PT |  | US |
| 8.24      | T27 digital input 4 destination                       | Pr 0.00 to 21.51  |            |    | Pr 6.32  | RW   | Uni | DE |    | PT |  | US |
| 8.25      | T28 digital input 5 destination                       | Pr 0.00 to 21.51  |            |    | Pr 1.41  | RW   | Uni | DE |    | PT |  | US |
| 8.26      | T29 digital input 6 destination {0.17}                | Pr 0.00 to 21.51  |            |    | Pr 6.31  | RW   | Uni | DE |    | PT |  | US |
| 8.27      | Relay source  | Pr 0.00 to 21.51  |            |    | Pr 10.01 | RW   | Uni |    |    | PT |  | US |
| 8.28      | T22 24V output source                                 | Pr 0.00 to 21.51  |            |    | Pr 0.00  | RW   | Uni |    |    | PT |  | US |
| 8.29      | Positive logic select {0.18}                          | OFF (0) or On (1) |            |    | On (1)   | RW   | Bit |    |    | PT |  | US |
| 8.30      | Open collector output                                 | OFF (0) or On (1) |            |    | OFF (0)  | RW   | Bit |    |    |    |  | US |
| 8.31      | T24 digital I/O 1 output select                       | OFF (0) or On (1) |            |    | On (1)   | RW   | Bit |    |    |    |  | US |
| 8.32      | T25 digital I/O 2 output select                       | OFF (0) or On (1) |            |    | OFF (0)  | RW   | Bit |    |    |    |  | US |
| 8.33      | T26 digital I/O 3 output select                       | OFF (0) or On (1) |            |    | OFF (0)  | RW   | Bit |    |    |    |  | US |
| 8.39      | T28 & T29 digital input auto-selection disable {0.16} | OFF (0) or On (1) |            |    | OFF (0)  | RW   | Bit |    |    |    |  | US |

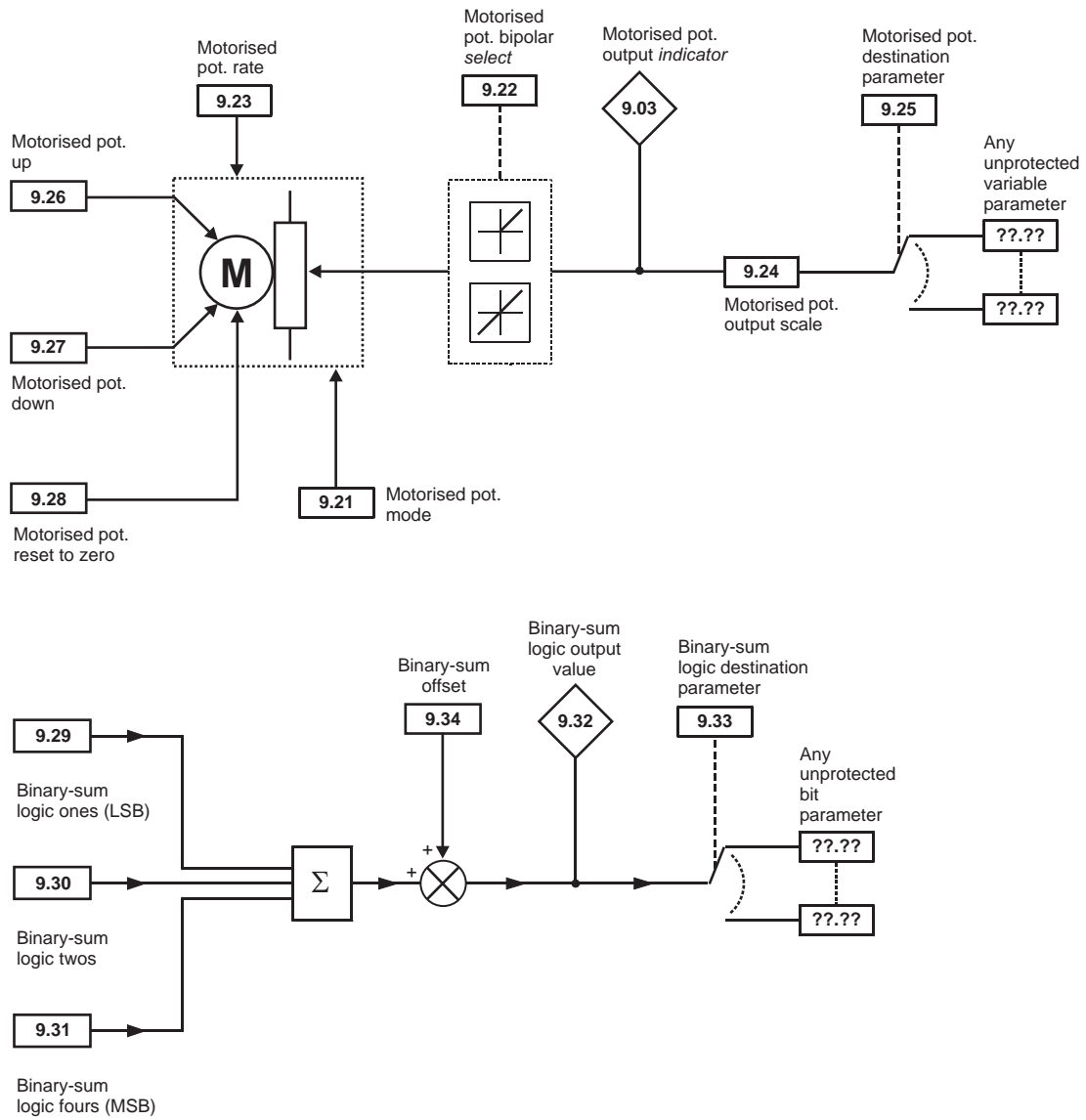
|    |              |    |             |     |            |    |                  |     |               |     |             |    |                 |
|----|--------------|----|-------------|-----|------------|----|------------------|-----|---------------|-----|-------------|----|-----------------|
| RW | Read / Write | RO | Read only   | Uni | Unipolar   | Bi | Bi-polar         | Bit | Bit parameter | Txt | Text string |    |                 |
| FI | Filtered     | DE | Destination | NC  | Not cloned | RA | Rating dependent | PT  | Protected     | US  | User save   | PS | Power down save |



## 11.9 Menu 9: Programmable logic, motorised pot and binary sum

Figure 11-13 Menu 9 logic diagram





| Parameter                             | Range(⇅)          |    | Default(⇔) |    |    | Type |     |    |    |    |    |    |
|---------------------------------------|-------------------|----|------------|----|----|------|-----|----|----|----|----|----|
|                                       | OL                | CL | OL         | VT | SV |      |     |    |    |    |    |    |
| 9.01 Logic function 1 output          | OFF (0) or On (1) |    |            |    |    | RO   | Bit |    | NC | PT |    |    |
| 9.02 Logic function 2 output          | OFF (0) or On (1) |    |            |    |    | RO   | Bit |    | NC | PT |    |    |
| 9.03 Motorised pot output             | ±100.00 %         |    |            |    |    | RO   | Bi  |    | NC | PT | PS |    |
| 9.04 Logic function 1 source 1        | Pr 0.00 to 21.51  |    | Pr 0.00    |    |    | RW   | Uni |    |    | PT | US |    |
| 9.05 Logic function 1 source 1 invert | OFF (0) or On (1) |    | OFF (0)    |    |    | RW   | Bit |    |    |    |    | US |
| 9.06 Logic function 1 source 2        | Pr 0.00 to 21.51  |    | Pr 0.00    |    |    | RW   | Uni |    |    | PT | US |    |
| 9.07 Logic function 1 source 2 invert | OFF (0) or On (1) |    | OFF (0)    |    |    | RW   | Bit |    |    |    |    | US |
| 9.08 Logic function 1 output invert   | OFF (0) or On (1) |    | OFF (0)    |    |    | RW   | Bit |    |    |    |    | US |
| 9.09 Logic function 1 delay           | ±25.0 s           |    | 0.0        |    |    | RW   | Bi  |    |    |    |    | US |
| 9.10 Logic function 1 destination     | Pr 0.00 to 21.51  |    | Pr 0.00    |    |    | RW   | Uni | DE |    | PT | US |    |
| 9.14 Logic function 2 source 1        | Pr 0.00 to 21.51  |    | Pr 0.00    |    |    | RW   | Uni |    |    | PT | US |    |
| 9.15 Logic function 2 source 1 invert | OFF (0) or On (1) |    | OFF (0)    |    |    | RW   | Bit |    |    |    |    | US |
| 9.16 Logic function 2 source 2        | Pr 0.00 to 21.51  |    | Pr 0.00    |    |    | RW   | Uni |    |    | PT | US |    |
| 9.17 Logic function 2 source 2 invert | OFF (0) or On (1) |    | OFF (0)    |    |    | RW   | Bit |    |    |    |    | US |
| 9.18 Logic function 2 output invert   | OFF (0) or On (1) |    | OFF (0)    |    |    | RW   | Bit |    |    |    |    | US |
| 9.19 Logic function 2 delay           | ±25.0 s           |    | 0.0        |    |    | RW   | Bi  |    |    |    |    | US |
| 9.20 Logic function 2 destination     | Pr 0.00 to 21.51  |    | Pr 0.00    |    |    | RW   | Uni | DE |    | PT | US |    |
| 9.21 Motorised pot mode               | 0 to 3            |    | 2          |    |    | RW   | Uni |    |    |    |    | US |
| 9.22 Motorised pot bipolar select     | OFF (0) or On (1) |    | OFF (0)    |    |    | RW   | Bit |    |    |    |    | US |
| 9.23 Motorised pot rate               | 0 to 250 s        |    | 20         |    |    | RW   | Uni |    |    |    |    | US |
| 9.24 Motorised pot scale factor       | 0.000 to 4.000    |    | 1.000      |    |    | RW   | Uni |    |    |    |    | US |
| 9.25 Motorised pot destination        | Pr 0.00 to 21.51  |    | Pr 0.00    |    |    | RW   | Uni | DE |    | PT | US |    |
| 9.26 Motorised pot up                 | OFF (0) or On (1) |    | OFF (0)    |    |    | RW   | Bit |    | NC |    |    |    |
| 9.27 Motorised pot down               | OFF (0) or On (1) |    | OFF (0)    |    |    | RW   | Bit |    | NC |    |    |    |
| 9.28 Motorised pot reset              | OFF (0) or On (1) |    | OFF (0)    |    |    | RW   | Bit |    | NC |    |    |    |
| 9.29 Binary sum ones input            | OFF (0) or On (1) |    | OFF (0)    |    |    | RW   | Bit |    | NC |    |    |    |
| 9.30 Binary sum twos input            | OFF (0) or On (1) |    | OFF (0)    |    |    | RW   | Bit |    | NC |    |    |    |
| 9.31 Binary sum fours input           | OFF (0) or On (1) |    | OFF (0)    |    |    | RW   | Bit |    | NC |    |    |    |
| 9.32 Binary sum output                | 0 to 255          |    |            |    |    | RO   | Uni |    | NC | PT |    |    |
| 9.33 Binary sum destination           | Pr 0.00 to 21.51  |    | Pr 0.00    |    |    | RW   | Uni | DE |    | PT | US |    |
| 9.34 Binary sum offset                | 0 to 248          |    | 0          |    |    | RW   | Uni |    |    |    |    | US |

|    |              |    |             |     |            |    |                  |     |               |     |             |    |                 |
|----|--------------|----|-------------|-----|------------|----|------------------|-----|---------------|-----|-------------|----|-----------------|
| RW | Read / Write | RO | Read only   | Uni | Unipolar   | Bi | Bi-polar         | Bit | Bit parameter | Txt | Text string |    |                 |
| FI | Filtered     | DE | Destination | NC  | Not cloned | RA | Rating dependent | PT  | Protected     | US  | User save   | PS | Power down save |

## 11.10 Menu 10: Status and trips

| Parameter | Range(⇅)   |                                      | Default(⇄) |    |    | Type |     |                |    |    |    |    |
|-----------|--|--------------------------------------|------------|----|----|------|-----|----------------|----|----|----|----|
|           | OL   | CL                                   | OL         | VT | SV |      |     |                |    |    |    |    |
| 10.01     | Drive healthy  | OFF (0) or On (1)                    |            |    |    | RO   | Bit |                | NC | PT |    |    |
| 10.02     | Drive active   | OFF (0) or On (1)                    |            |    |    | RO   | Bit |                | NC | PT |    |    |
| 10.03     | Zero speed   | OFF (0) or On (1)                    |            |    |    | RO   | Bit |                | NC | PT |    |    |
| 10.04     | Running at or below minimum speed                        | OFF (0) or On (1)                    |            |    |    | RO   | Bit |                | NC | PT |    |    |
| 10.05     | Below set speed  | OFF (0) or On (1)                    |            |    |    | RO   | Bit |                | NC | PT |    |    |
| 10.06     | At speed   | OFF (0) or On (1)                    |            |    |    | RO   | Bit |                | NC | PT |    |    |
| 10.07     | Above set speed  | OFF (0) or On (1)                    |            |    |    | RO   | Bit |                | NC | PT |    |    |
| 10.08     | Load reached   | OFF (0) or On (1)                    |            |    |    | RO   | Bit |                | NC | PT |    |    |
| 10.09     | Drive output is at current limit                         | OFF (0) or On (1)                    |            |    |    | RO   | Bit |                | NC | PT |    |    |
| 10.10     | Regenerating   | OFF (0) or On (1)                    |            |    |    | RO   | Bit |                | NC | PT |    |    |
| 10.11     | Braking IGBT active                                      | OFF (0) or On (1)                    |            |    |    | RO   | Bit |                | NC | PT |    |    |
| 10.12     | Braking resistor alarm                                   | OFF (0) or On (1)                    |            |    |    | RO   | Bit |                | NC | PT |    |    |
| 10.13     | Direction commanded                                      | OFF (0) or On (1) [0 = FWD, 1 = REV] |            |    |    | RO   | Bit |                | NC | PT |    |    |
| 10.14     | Direction running  | OFF (0) or On (1) [0 = FWD, 1 = REV] |            |    |    | RO   | Bit |                | NC | PT |    |    |
| 10.15     | Mains loss   | OFF (0) or On (1)                    |            |    |    | RO   | Bit |                | NC | PT |    |    |
| 10.16     | Under voltage active                                     | OFF (0) or On (1)                    |            |    |    | RO   | Bit |                | NC | PT |    |    |
| 10.17     | Overload alarm   | OFF (0) or On (1)                    |            |    |    | RO   | Bit |                | NC | PT |    |    |
| 10.18     | Drive over temperature alarm                             | OFF (0) or On (1)                    |            |    |    | RO   | Bit |                | NC | PT |    |    |
| 10.19     | Drive warning  | OFF (0) or On (1)                    |            |    |    | RO   | Bit |                | NC | PT |    |    |
| 10.20     | Trip 0   | 0 to 230*                            |            |    |    | RO   | Txt |                | NC | PT | PS |    |
| 10.21     | Trip 1   | 0 to 230*                            |            |    |    | RO   | Txt |                | NC | PT | PS |    |
| 10.22     | Trip 2   | 0 to 230*                            |            |    |    | RO   | Txt |                | NC | PT | PS |    |
| 10.23     | Trip 3   | 0 to 230*                            |            |    |    | RO   | Txt |                | NC | PT | PS |    |
| 10.24     | Trip 4   | 0 to 230*                            |            |    |    | RO   | Txt |                | NC | PT | PS |    |
| 10.25     | Trip 5   | 0 to 230*                            |            |    |    | RO   | Txt |                | NC | PT | PS |    |
| 10.26     | Trip 6   | 0 to 230*                            |            |    |    | RO   | Txt |                | NC | PT | PS |    |
| 10.27     | Trip 7   | 0 to 230*                            |            |    |    | RO   | Txt |                | NC | PT | PS |    |
| 10.28     | Trip 8   | 0 to 230*                            |            |    |    | RO   | Txt |                | NC | PT | PS |    |
| 10.29     | Trip 9   | 0 to 230*                            |            |    |    | RO   | Txt |                | NC | PT | PS |    |
| 10.30     | Full power braking time                                  | 0.00 to 400.00 s                     |            |    |    |      |     | See Table 11-7 |    |    |    | US |
| 10.31     | Full power braking period                                | 0.0 to 1500.0 s                      |            |    |    |      |     | See Table 11-7 |    |    |    | US |
| 10.32     | External trip  | OFF (0) or On (1)                    |            |    |    | RW   | Bit | OFF (0)        |    | NC |    |    |
| 10.33     | Drive reset  | OFF (0) or On (1)                    |            |    |    | RW   | Bit | OFF (0)        |    | NC |    |    |
| 10.34     | No. of auto-reset attempts                               | 0 to 5                               |            |    |    | RW   | Uni | 0              |    |    |    | US |
| 10.35     | Auto-reset delay   | 0.0 to 25.0 s                        |            |    |    | RW   | Uni | 1.0            |    |    |    | US |
| 10.36     | Hold drive healthy until last attempt                    | OFF (0) or On (1)                    |            |    |    | RW   | Bit | OFF (0)        |    |    |    | US |
| 10.37     | Action on trip detection                                 | 0 to 3                               |            |    |    | RW   | Uni | 0              |    |    |    | US |
| 10.38     | User trip  | 0 to 255                             |            |    |    | RW   | Uni | 0              |    | NC |    |    |
| 10.39     | Braking energy overload accumulator                      | 0.0 to 100.0 %                       |            |    |    | RO   | Uni |                |    | NC | PT |    |
| 10.40     | Status word  | 0 to 32,767                          |            |    |    | RO   | Uni |                |    | NC | PT |    |
| 10.41     | Trip 0 time: years.days                                  | 0.000 to 9.365 years.days            |            |    |    | RO   | Uni |                |    | NC | PT | PS |
| 10.42     | Module number for trip 0, or, Trip 0 time: hours.minutes | 00.00 to 23.59 hours.minutes         |            |    |    | RO   | Uni |                |    | NC | PT | PS |
| 10.43     | Module number for trip 1, or, Trip 1 time                | 0 to 600.00 hours.minutes            |            |    |    | RO   | Uni |                |    | NC | PT | PS |
| 10.44     | Module number for trip 2, or, Trip 2 time                | 0 to 600.00 hours.minutes            |            |    |    | RO   | Uni |                |    | NC | PT | PS |
| 10.45     | Module number for trip 3, or, Trip 3 time                | 0 to 600.00 hours.minutes            |            |    |    | RO   | Uni |                |    | NC | PT | PS |
| 10.46     | Module number for trip 4, or, Trip 4 time                | 0 to 600.00 hours.minutes            |            |    |    | RO   | Uni |                |    | NC | PT | PS |
| 10.47     | Module number for trip 5, or, Trip 5 time                | 0 to 600.00 hours.minutes            |            |    |    | RO   | Uni |                |    | NC | PT | PS |
| 10.48     | Module number for trip 6, or, Trip 6 time                | 0 to 600.00 hours.minutes            |            |    |    | RO   | Uni |                |    | NC | PT | PS |
| 10.49     | Module number for trip 7, or, Trip 7 time                | 0 to 600.00 hours.minutes            |            |    |    | RO   | Uni |                |    | NC | PT | PS |
| 10.50     | Module number for trip 8, or, Trip 8 time                | 0 to 600.00 hours.minutes            |            |    |    | RO   | Uni |                |    | NC | PT | PS |
| 10.51     | Module number for trip 9, or, Trip 9 time                | 0 to 600.00 hours.minutes            |            |    |    | RO   | Uni |                |    | NC | PT | PS |

|    |              |    |             |     |            |    |                  |     |               |     |             |    |                 |
|----|--------------|----|-------------|-----|------------|----|------------------|-----|---------------|-----|-------------|----|-----------------|
| RW | Read / Write | RO | Read only   | Uni | Unipolar   | Bi | Bi-polar         | Bit | Bit parameter | Txt | Text string |    |                 |
| Fl | Filtered     | DE | Destination | NC  | Not cloned | RA | Rating dependent | PT  | Protected     | US  | User save   | PS | Power down save |

\*The value given for the range is that obtained via serial communication. For the text string displayed on the drive, see Chapter 13 *Diagnostics* on page 275.

**Table 11-7 Defaults for Pr 10.30 and Pr 10.31**

| Drive rating                      | Pr 10.30 | Pr 10.31 |
|-----------------------------------|----------|----------|
| 200V, size 1 & 2                  | 0.04     | 2.0      |
| 400V, size 1 & 2                  | 0.02     | 2.0      |
| All other ratings and frame sizes | 0.00     |          |

## 11.11 Menu 11: General drive set-up

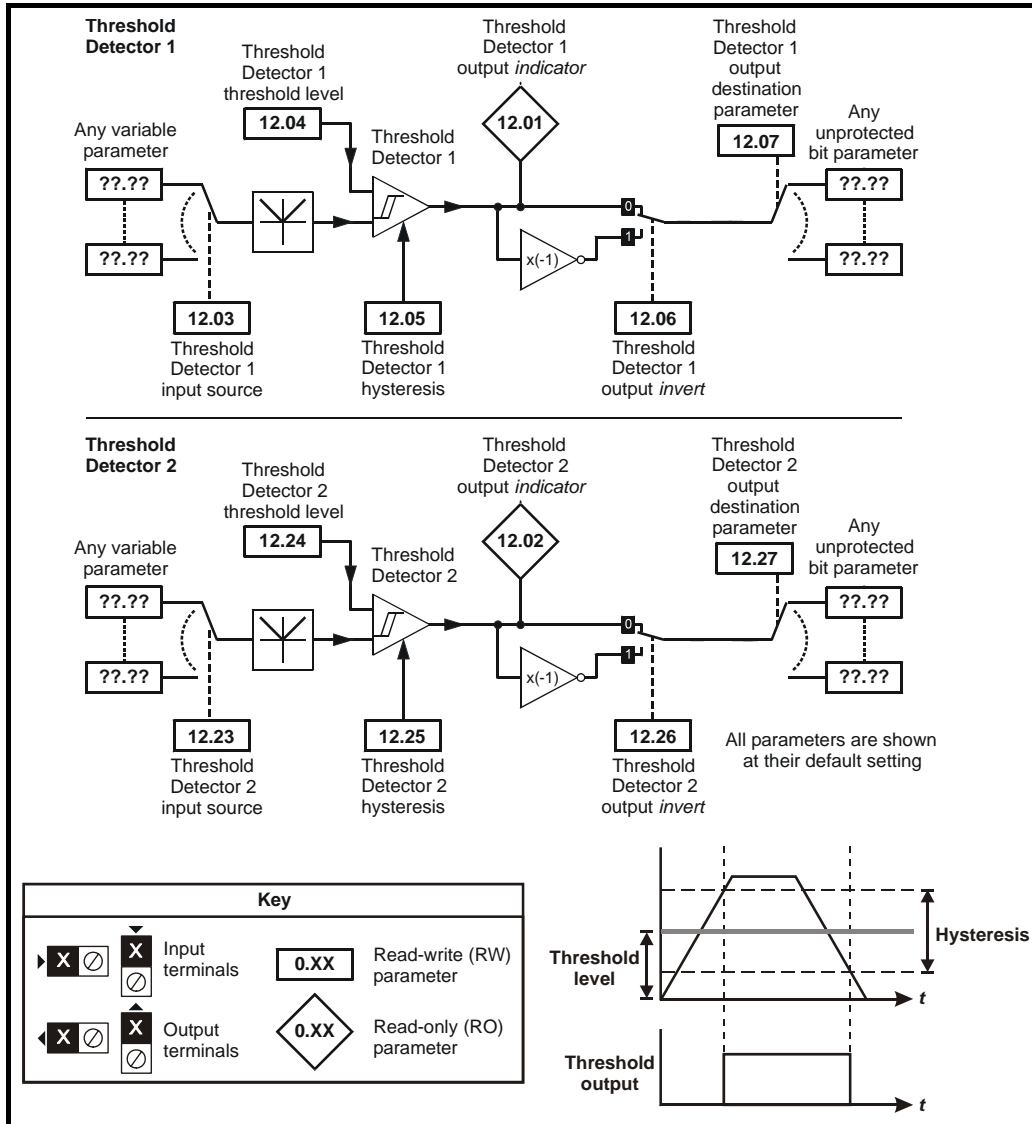
| Parameter   | Range(⇅)   |    | Default(⇔)                           |             |           | Type |     |    |    |    |
|---|--|----|--------------------------------------|-------------|-----------|------|-----|----|----|----|
|   | OL   | CL | OL                                   | VT          | SV        |      |     |    |    |    |
| 11.01 Parameter 0.11 set up                             | Pr 1.00 to 21.51   |    | Pr 5.01                              |             | Pr 3.29   | RW   | Uni |    | PT | US |
| 11.02 Parameter 0.12 set up                             | Pr 1.00 to 21.51   |    | Pr 4.01                              |             |           | RW   | Uni |    | PT | US |
| 11.03 Parameter 0.13 set up                             | Pr 1.00 to 21.51   |    | Pr 4.02                              |             | Pr 7.07   | RW   | Uni |    | PT | US |
| 11.04 Parameter 0.14 set up                             | Pr 1.00 to 21.51   |    | Pr 4.11                              |             |           | RW   | Uni |    | PT | US |
| 11.05 Parameter 0.15 set up                             | Pr 1.00 to 21.51   |    | Pr 2.04                              |             |           | RW   | Uni |    | PT | US |
| 11.06 Parameter 0.16 set up                             | Pr 1.00 to 21.51   |    | Pr 8.39                              | Pr 2.02     |           | RW   | Uni |    | PT | US |
| 11.07 Parameter 0.17 set up                             | Pr 1.00 to 21.51   |    | Pr 8.26                              | Pr 4.12     |           | RW   | Uni |    | PT | US |
| 11.08 Parameter 0.18 set up                             | Pr 1.00 to 21.51   |    | Pr 8.29                              |             |           | RW   | Uni |    | PT | US |
| 11.09 Parameter 0.19 set up                             | Pr 1.00 to 21.51   |    | Pr 7.11                              |             |           | RW   | Uni |    | PT | US |
| 11.10 Parameter 0.20 set up                             | Pr 1.00 to 21.51   |    | Pr 7.14                              |             |           | RW   | Uni |    | PT | US |
| 11.11 Parameter 0.21 set up                             | Pr 1.00 to 21.51   |    | Pr 7.15                              |             |           | RW   | Uni |    | PT | US |
| 11.12 Parameter 0.22 set up                             | Pr 1.00 to 21.51   |    | Pr 1.10                              |             |           | RW   | Uni |    | PT | US |
| 11.13 Parameter 0.23 set up                             | Pr 1.00 to 21.51   |    | Pr 1.05                              |             |           | RW   | Uni |    | PT | US |
| 11.14 Parameter 0.24 set up                             | Pr 1.00 to 21.51   |    | Pr 1.21                              |             |           | RW   | Uni |    | PT | US |
| 11.15 Parameter 0.25 set up                             | Pr 1.00 to 21.51   |    | Pr 1.22                              |             |           | RW   | Uni |    | PT | US |
| 11.16 Parameter 0.26 set up                             | Pr 1.00 to 21.51   |    | Pr 1.23                              | Pr 3.08     |           | RW   | Uni |    | PT | US |
| 11.17 Parameter 0.27 set up                             | Pr 1.00 to 21.51   |    | Pr 1.24                              | Pr 3.34     |           | RW   | Uni |    | PT | US |
| 11.18 Parameter 0.28 set up                             | Pr 1.00 to 21.51   |    | Pr 6.13                              |             |           | RW   | Uni |    | PT | US |
| 11.19 Parameter 0.29 set up                             | Pr 1.00 to 21.51   |    | Pr 11.36                             |             |           | RW   | Uni |    | PT | US |
| 11.20 Parameter 0.30 set up                             | Pr 1.00 to 21.51   |    | Pr 11.42                             |             |           | RW   | Uni |    | PT | US |
| 11.21 Parameter scaling                                 | 0.000 to 9.999   |    | 1.000                                |             |           | RW   | Uni |    |    | US |
| 11.22 Parameter displayed at power-up                   | Pr 0.00 to 00.50   |    | Pr 0.10                              |             |           | RW   | Uni |    | PT | US |
| 11.23 Serial address {0.37}                             | 0 to 247   |    | 1                                    |             |           | RW   | Uni |    |    | US |
| 11.24 Serial mode {0.35}                                | AnSI (0), rTU (1), Lcd (2)   |    | rtU (1)                              |             |           | RW   | Txt |    | PT | US |
| 11.25 Baud rate {0.36}                                  | 300 (0), 600 (1), 1200 (2), 2400 (3), 4800 (4), 9600 (5), 19200 (6), 38400 (7), 57600 (8)*, 115200 (9)* *Modbus RTU only |    | 19200 (6)                            |             |           | RW   | Txt |    |    | US |
| 11.26 Minimum comms transmit delay                      | 0 to 250ms   |    | 2                                    |             |           | RW   | Uni |    |    | US |
| 11.28 Drive derivative                                  | 0 to 16  |    |                                      |             |           | RO   | Uni | NC | PT |    |
| 11.29 Software version {0.50}                           | 1.00 to 99.99  |    |                                      |             |           | RO   | Uni | NC | PT |    |
| 11.30 User security code {0.34}                         | 0 to 999   |    | 0                                    |             |           | RW   | Uni | NC | PT | PS |
| 11.31 User drive mode {0.48}                            | OPEn LP (1), CL VECt (2), SErVO (3), rEGEn (4)   |    | OPEn LP (1)                          | CL VECt (2) | SErVO (3) | RW   | Txt | NC | PT |    |
| 11.32 Maximum Heavy Duty current rating {0.32}          | 0.00 to 9999.99A   |    |                                      |             |           | RO   | Uni | NC | PT |    |
| 11.33 Drive voltage rating {0.31}                       | 200 (0), 400 (1), 575 (2), 690 (3)   |    |                                      |             |           | RO   | Txt | NC | PT |    |
| 11.34 Software sub-version                              | 0 to 99  |    |                                      |             |           | RO   | Uni | NC | PT |    |
| 11.35 Number of modules                                 | 1 to 10  |    |                                      |             |           | RO   | Uni | NC | PT |    |
| 11.36 SMARTCARD parameter data previously loaded {0.29} | 0 to 999   |    | 0                                    |             |           | RO   | Uni | NC | PT | US |
| 11.37 SMARTCARD data number                             | 0 to 1000  |    | 0                                    |             |           | RW   | Uni | NC |    |    |
| 11.38 SMARTCARD data type / mode                        | 0 to 18  |    |                                      |             |           | RO   | Txt | NC | PT |    |
| 11.39 SMARTCARD data version                            | 0 to 9,999   |    | 0                                    |             |           | RW   | Uni | NC |    |    |
| 11.40 SMARTCARD data checksum                           | 0 to 65,335  |    |                                      |             |           | RO   | Uni | NC | PT |    |
| 11.41 Status mode timeout                               | 0 to 250s  |    | 240                                  |             |           | RW   | Uni |    |    | US |
| 11.42 Parameter cloning {0.30}                          | nonE (0), rEAd (1), Prog (2), AutoO (3), boot (4)  |    | nonE (0)                             |             |           | RW   | Txt | NC |    | *  |
| 11.43 Load defaults                                     | nonE (0), Eur (1), USA (2)   |    | nonE (0)                             |             |           | RW   | Txt | NC |    |    |
| 11.44 Security status {0.49}                            | L1 (0), L2 (1), Loc (2)  |    |                                      |             |           | RW   | Txt |    | PT | US |
| 11.45 Select motor 2 parameters                         | OFF (0) or On (1)  |    | OFF (0)                              |             |           | RW   | Bit |    |    | US |
| 11.46 Defaults previously loaded                        | 0 to 2000  |    |                                      |             |           | RO   | Uni | NC | PT | US |
| 11.47 Drive Onboard PLC program enable                  | Halt program (0)<br>Run program: out of range = clip (1)<br>Run program: out of range = trip (2)                         |    | Run program: out of range = trip (2) |             |           | RW   | Uni |    |    | US |
| 11.48 Drive Onboard PLC program status                  | -128 to +127   |    |                                      |             |           | RO   | Bi  | NC | PT |    |
| 11.49 Drive Onboard PLC programming events              | 0 to 65,535  |    |                                      |             |           | RO   | Uni | NC | PT | PS |
| 11.50 Drive Onboard PLC program maximum scan time       | 0 to 65,535 ms   |    |                                      |             |           | RO   | Uni | NC | PT |    |
| 11.51 Drive Onboard PLC program first run               | OFF (0) or On (1)  |    |                                      |             |           | RO   | Bit | NC | PT |    |

\* Modes 1 and 2 are not user saved, Modes 0, 3 and 4 are user saved

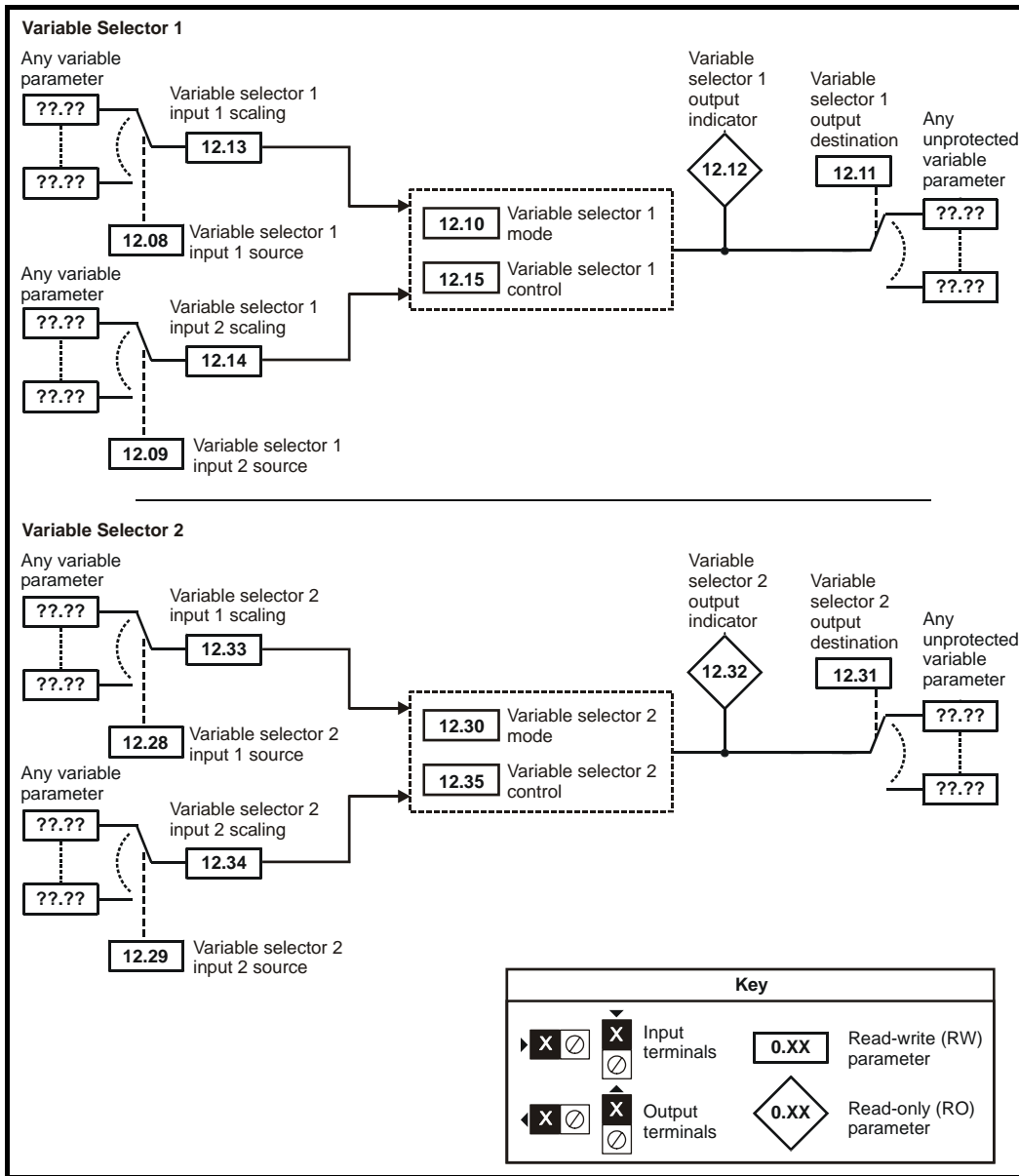
|    |              |    |             |     |            |    |                  |     |               |     |             |    |                 |
|----|--------------|----|-------------|-----|------------|----|------------------|-----|---------------|-----|-------------|----|-----------------|
| RW | Read / Write | RO | Read only   | Uni | Unipolar   | Bi | Bi-polar         | Bit | Bit parameter | Txt | Text string |    |                 |
| FI | Filtered     | DE | Destination | NC  | Not cloned | RA | Rating dependent | PT  | Protected     | US  | User save   | PS | Power down save |

## 11.12 Menu 12: Threshold detectors, variable selectors and brake control function

Figure 11-14 Menu 12 logic diagram



**Figure 11-15 Menu 12 logic diagram (continued)**

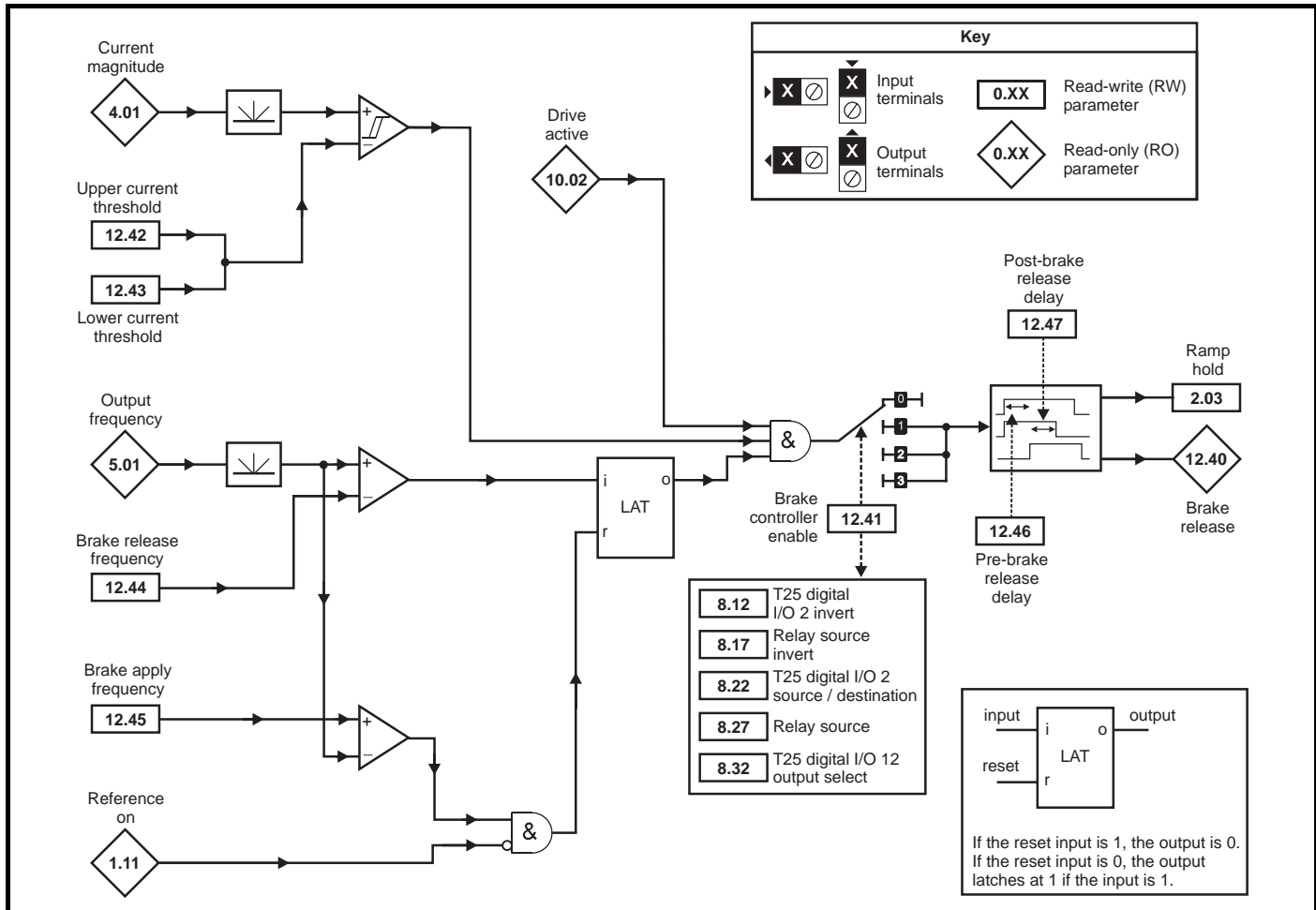




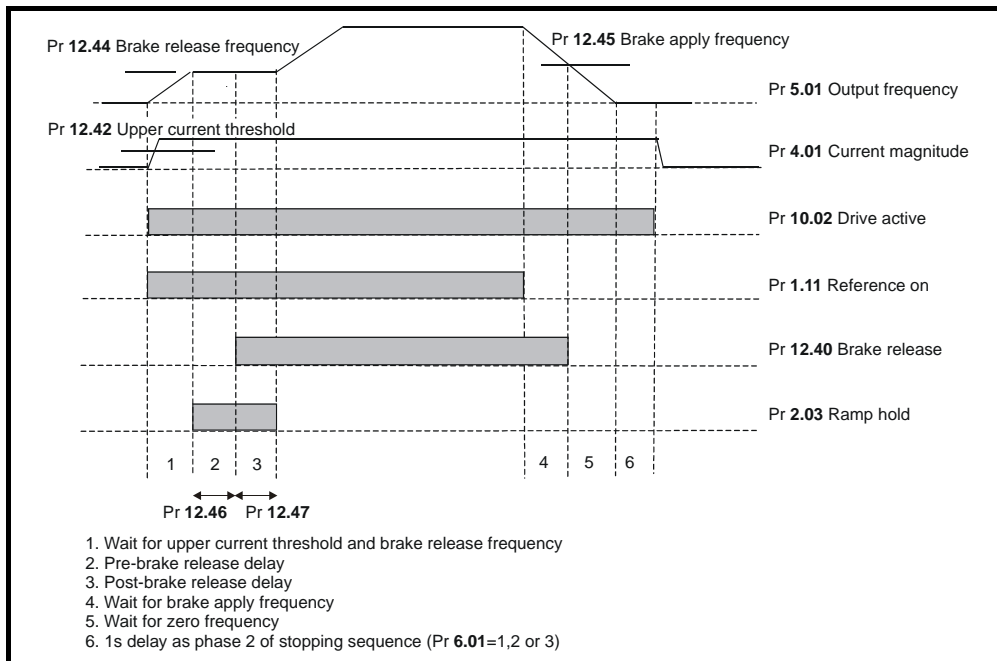
The control terminal relay can be selected as an output to release a brake. If a drive is set up in this manner and a drive replacement takes place, prior to programming the drive on initial power up, the brake may be released.

When drive terminals are programmed to non default settings the result of incorrect or delayed programming must be considered. The use of a Smartcard in boot mode or an SM-Applications module can ensure drive parameters are immediately programmed to avoid this situation.

**Figure 11-16 Open-loop brake function**



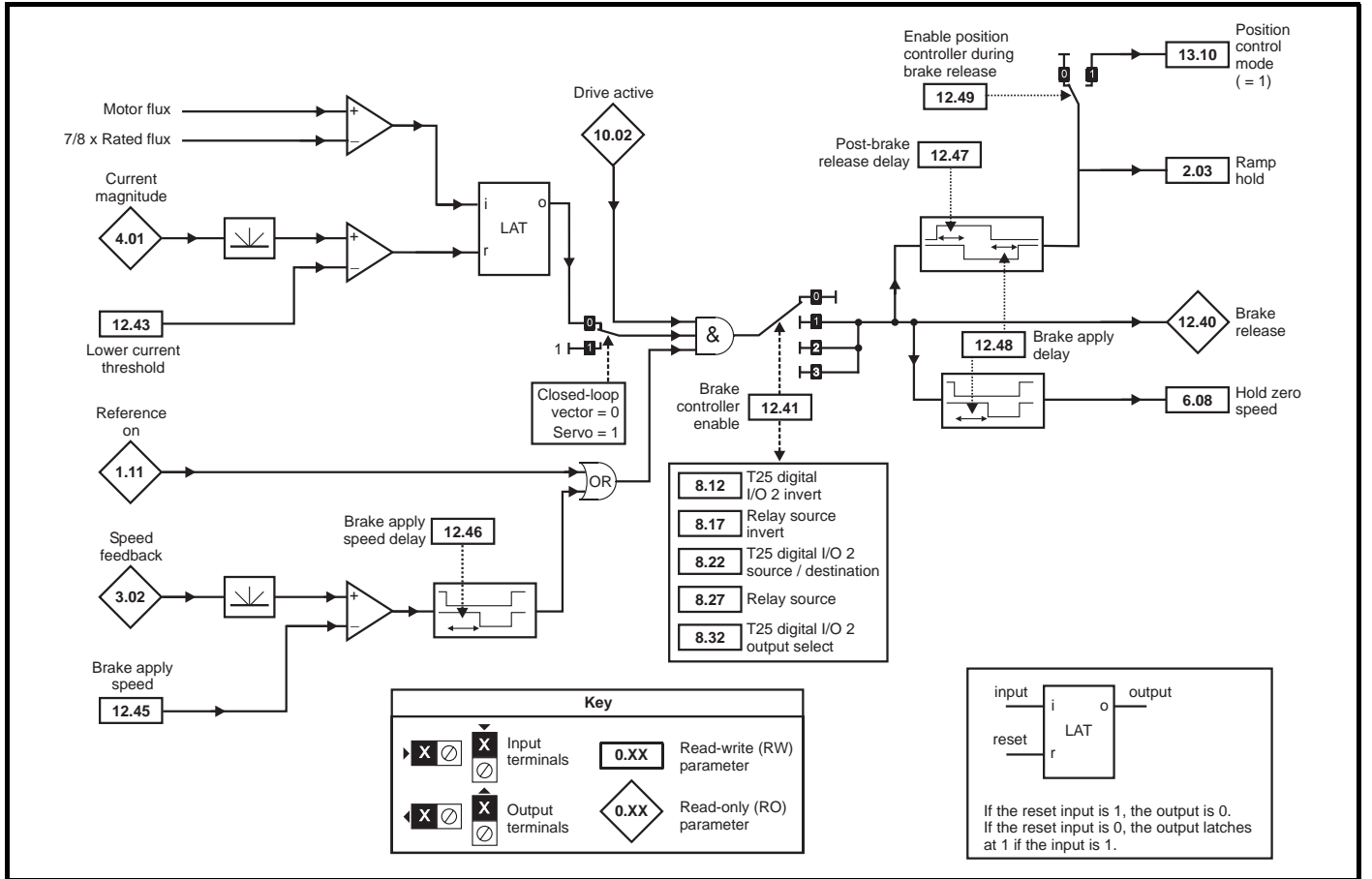
**Figure 11-17 Open-loop brake sequence**



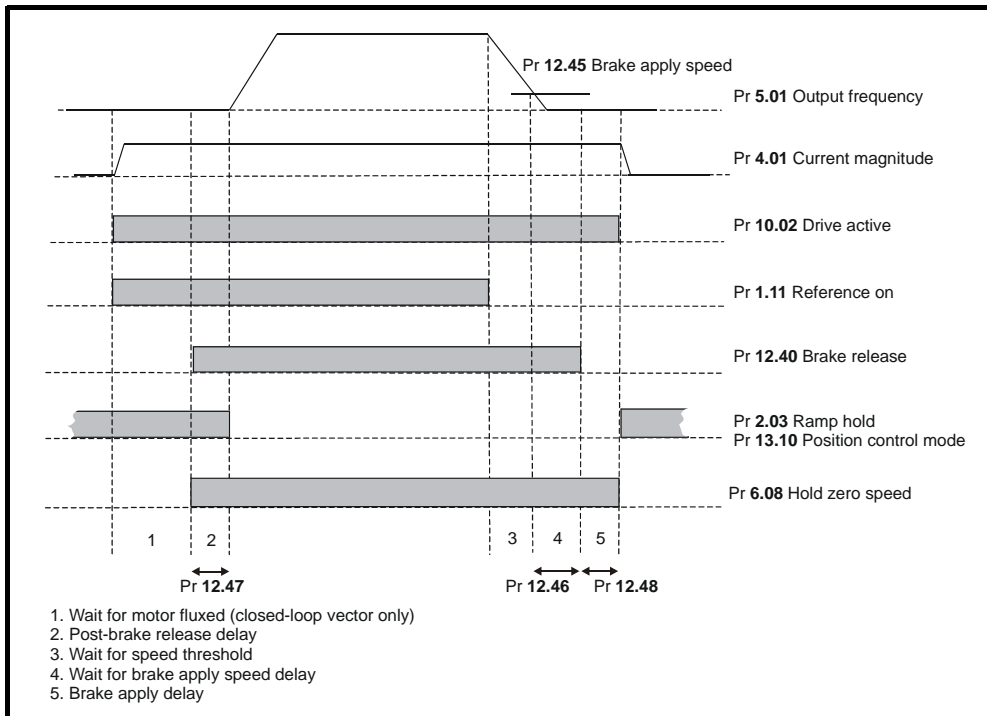


The control terminal relay can be selected as an output to release a brake. If a drive is set up in this manner and a drive replacement takes place, prior to programming the drive on initial power up, the brake may be released. When drive terminals are programmed to non default settings the result of incorrect or delayed programming must be considered. The use of a Smartcard in boot mode or an SM-Applications module can ensure drive parameters are immediately programmed to avoid this situation.

**Figure 11-18 Closed-loop brake function**



**Figure 11-19 Closed-loop brake sequence**





The control terminal relay can be selected as an output to release a brake. If a drive is set up in this manner and a drive replacement takes place, prior to programming the drive on initial power up, the brake may be released.

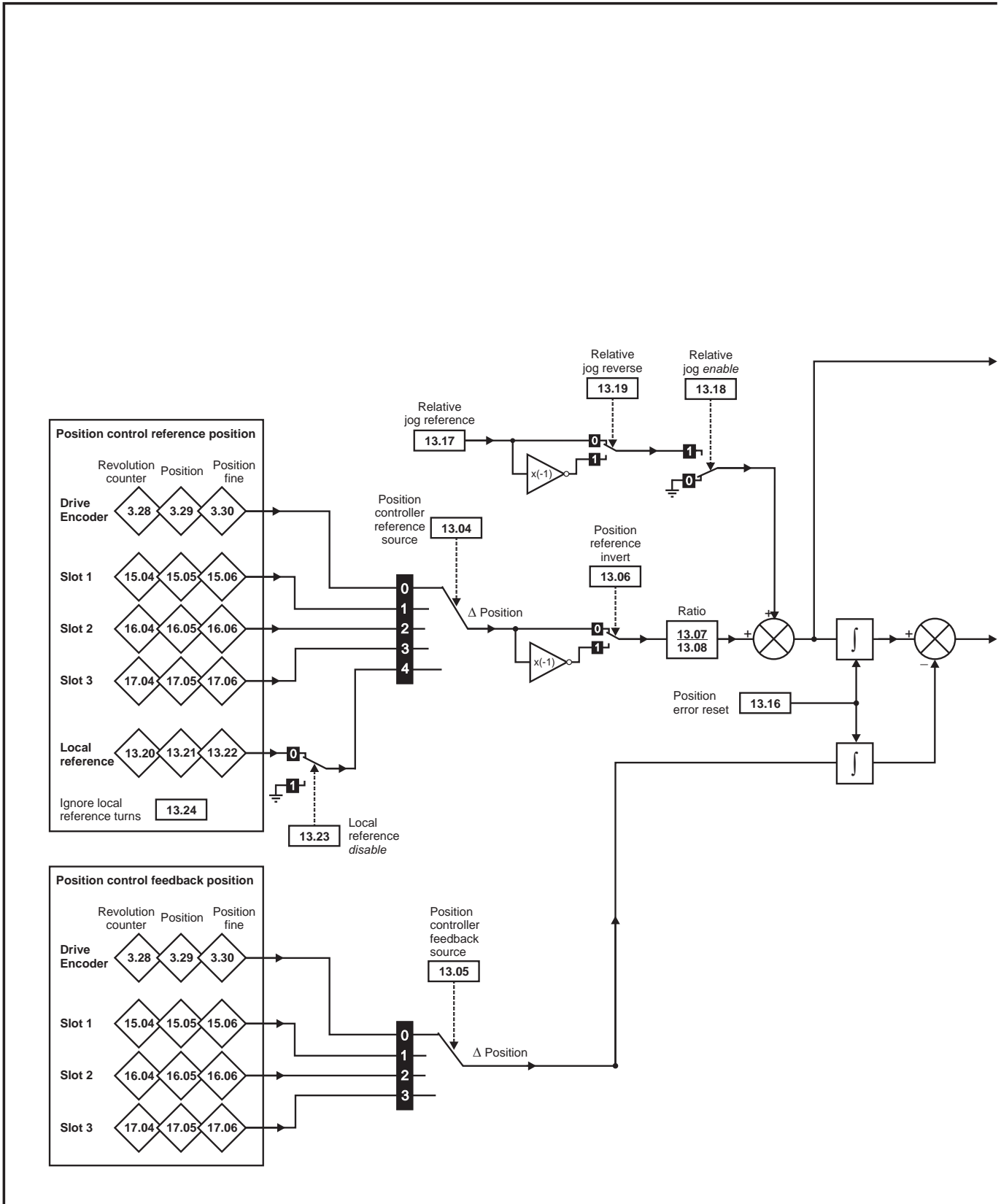
When drive terminals are programmed to non default settings the result of incorrect or delayed programming must be considered. The use of a Smartcard in boot mode or an SM-Applications module can ensure drive parameters are immediately programmed to avoid this situation.

| Parameter | Range(⇅)  |    | Default(⇄)  |    |    | Type    |     |    |          |    |    |
|-----------|---|----|---|----|----|---------|-----|----|----------|----|----|
|           | OL  | CL | OL  | VT | SV |         |     |    |          |    |    |
| 12.01     | Threshold detector 1 output                     |    | OFF (0) or On (1)   |    |    | RO      | Bit |    | NC       | PT |    |
| 12.02     | Threshold detector 2 output                     |    | OFF (0) or On (1)   |    |    | RO      | Bit |    | NC       | PT |    |
| 12.03     | Threshold detector 1 source                     |    | Pr 0.00 to 21.51  |    |    | RW      | Uni |    |          | PT | US |
| 12.04     | Threshold detector 1 level                      |    | 0.00 to 100.00 %  |    |    | RW      | Uni |    |          |    | US |
| 12.05     | Threshold detector 1 hysteresis                 |    | 0.00 to 25.00 %   |    |    | RW      | Uni |    |          |    | US |
| 12.06     | Threshold detector 1 output invert              |    | OFF (0) or On (1)   |    |    | RW      | Bit |    |          |    | US |
| 12.07     | Threshold detector 1 destination                |    | Pr 0.00 to 21.51  |    |    | RW      | Uni | DE |          | PT | US |
| 12.08     | Variable selector 1 source 1                    |    | Pr 0.00 to 21.51  |    |    | RW      | Uni |    |          | PT | US |
| 12.09     | Variable selector 1 source 2                    |    | Pr 0.00 to 21.51  |    |    | RW      | Uni |    |          | PT | US |
| 12.10     | Variable selector 1 mode                        |    | Select input 1 (0), select input 2 (1), add (2), subtract (3), multiply (4), divide (5), time constant (6), linear ramp (7), modulus (8), powers (9), sectional control (10), external rectifier monitor (11) |    |    | RW      | Uni |    |          |    | US |
| 12.11     | Variable selector 1 destination                 |    | Pr 0.00 to 21.51  |    |    | RW      | Uni | DE |          | PT | US |
| 12.12     | Variable selector 1 output                      |    | ±100.00 %   |    |    | RO      | Bi  |    | NC       | PT |    |
| 12.13     | Variable selector 1 source 1 scaling            |    | ±4.000  |    |    | RW      | Bi  |    |          |    | US |
| 12.14     | Variable selector 1 source 2 scaling            |    | ±4.000  |    |    | RW      | Bi  |    |          |    | US |
| 12.15     | Variable selector 1 control                     |    | 0.00 to 100.00 s  |    |    | RW      | Uni |    |          |    | US |
| 12.23     | Threshold detector 2 source                     |    | Pr 0.00 to 21.51  |    |    | RW      | Uni |    |          | PT | US |
| 12.24     | Threshold detector 2 level                      |    | 0.00 to 100.00 %  |    |    | RW      | Uni |    |          |    | US |
| 12.25     | Threshold detector 2 hysteresis                 |    | 0.00 to 25.00 %   |    |    | RW      | Uni |    |          |    | US |
| 12.26     | Threshold detector 2 output invert              |    | OFF (0) or On (1)   |    |    | RW      | Bit |    |          |    | US |
| 12.27     | Threshold detector 2 destination                |    | Pr 0.00 to 21.51  |    |    | RW      | Uni | DE |          | PT | US |
| 12.28     | Variable selector 2 source 1                    |    | Pr 0.00 to 21.51  |    |    | RW      | Uni |    |          | PT | US |
| 12.29     | Variable selector 2 source 2                    |    | Pr 0.00 to 21.51  |    |    | RW      | Uni |    |          | PT | US |
| 12.30     | Variable selector 2 mode                        |    | Select input 1 (0), select input 2 (1), add (2), subtract (3), multiply (4), divide (5), time constant (6), linear ramp (7), modulus (8), powers (9), sectional control (10), external rectifier monitor (11) |    |    | RW      | Uni |    |          |    | US |
| 12.31     | Variable selector 2 destination                 |    | Pr 0.00 to 21.51  |    |    | RW      | Uni | DE |          | PT | US |
| 12.32     | Variable selector 2 output                      |    | ±100.00 %   |    |    | RO      | Bi  |    | NC       | PT |    |
| 12.33     | Variable selector 2 source 1 scaling            |    | ±4.000  |    |    | RW      | Bi  |    |          |    | US |
| 12.34     | Variable selector 2 source 2 scaling            |    | ±4.000  |    |    | RW      | Bi  |    |          |    | US |
| 12.35     | Variable selector 2 control                     |    | 0.00 to 100.00 s  |    |    | RW      | Uni |    |          |    | US |
| 12.40     | Brake release indicator                         |    | OFF (0) or On (1)   |    |    | RO      | Bit |    | NC       | PT |    |
| 12.41     | Brake controller enable                         |    | dis (0), rEL (1), d IO (2), USEr (3)  |    |    | RW      | Txt |    |          |    | US |
| 12.42     | Upper current threshold                         |    | 0 to 200 %  |    |    | RW      | Uni |    |          |    | US |
| 12.43     | Lower current threshold                         |    | 0 to 200 %  |    |    | RW      | Uni |    |          |    | US |
| 12.44     | Brake release frequency                         |    | 0.0 to 20.0 Hz  |    |    | RW      | Uni |    |          |    | US |
| 12.45     | Brake apply frequency / speed                   |    | 0.0 to 20.0 Hz      0 to 200 rpm  |    |    | RW      | Bit |    |          |    | US |
| 12.46     | OL> Pre-brake release delay                     |    | 0.0 to 25.0 s   |    |    | 1.0     |     |    | RW   Uni |    |    |
|           | CL> Brake apply speed delay                     |    |   |    |    |         |     |    |          |    |    |
| 12.47     | Post brake release delay                        |    | 0.0 to 25.0 s   |    |    | 1.0     |     |    | RW   Uni |    |    |
| 12.48     | Brake apply delay                               |    | 0.0 to 25.0 s   |    |    | 1.0     |     |    | RW   Uni |    |    |
| 12.49     | Enable position controller during brake release |    | OFF (0) or On (1)   |    |    | OFF (0) |     |    | RW   Bit |    |    |

|    |              |    |             |     |            |    |                  |     |               |     |             |    |                 |
|----|--------------|----|-------------|-----|------------|----|------------------|-----|---------------|-----|-------------|----|-----------------|
| RW | Read / Write | RO | Read only   | Uni | Unipolar   | Bi | Bi-polar         | Bit | Bit parameter | Txt | Text string |    |                 |
| FI | Filtered     | DE | Destination | NC  | Not cloned | RA | Rating dependent | PT  | Protected     | US  | User save   | PS | Power down save |

## 11.13 Menu 13: Position control

Figure 11-20 Menu 13 Open-loop logic diagram



\*For more information, refer to section 11.21.9 *Position modes* on page 255.

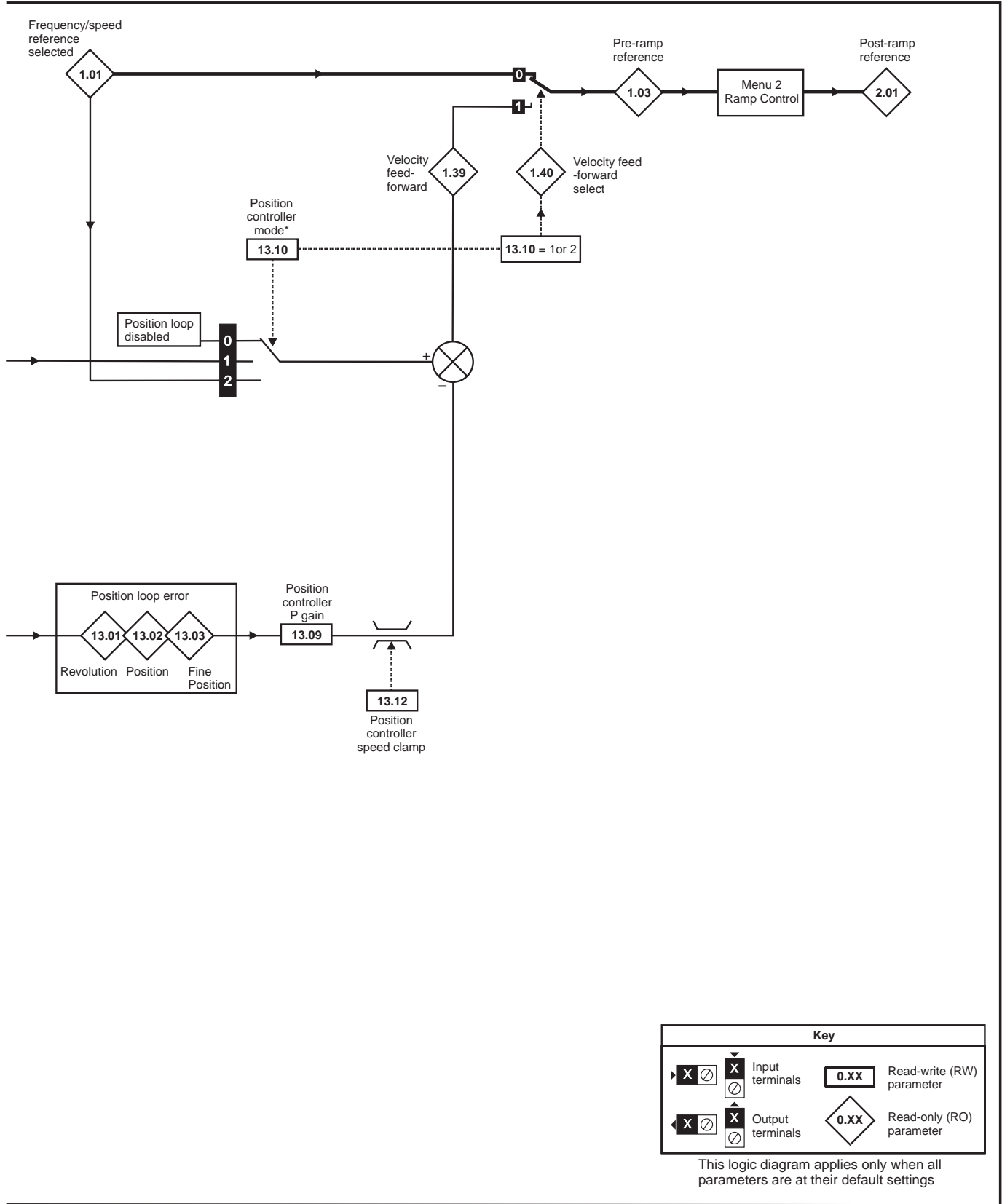
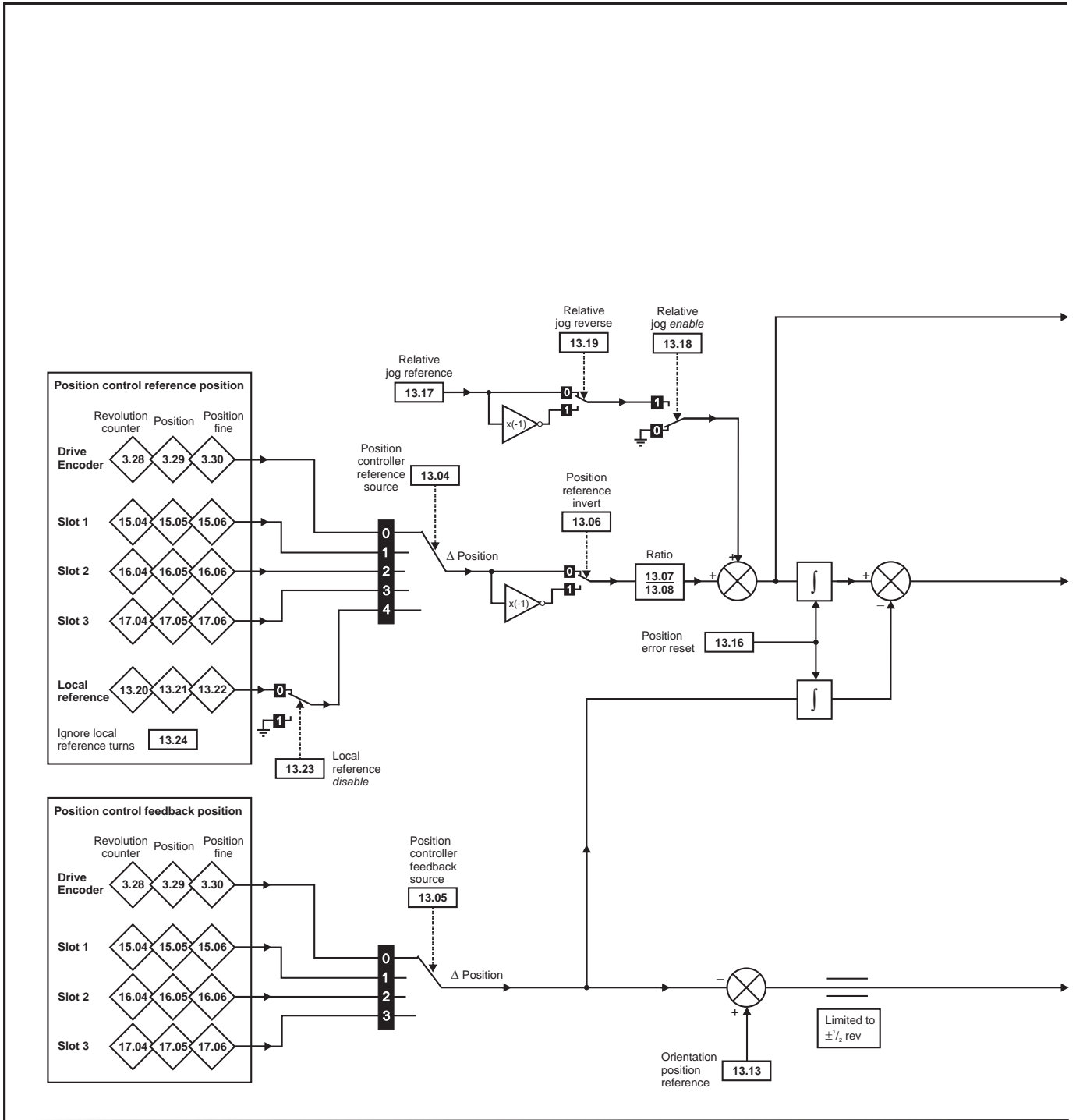
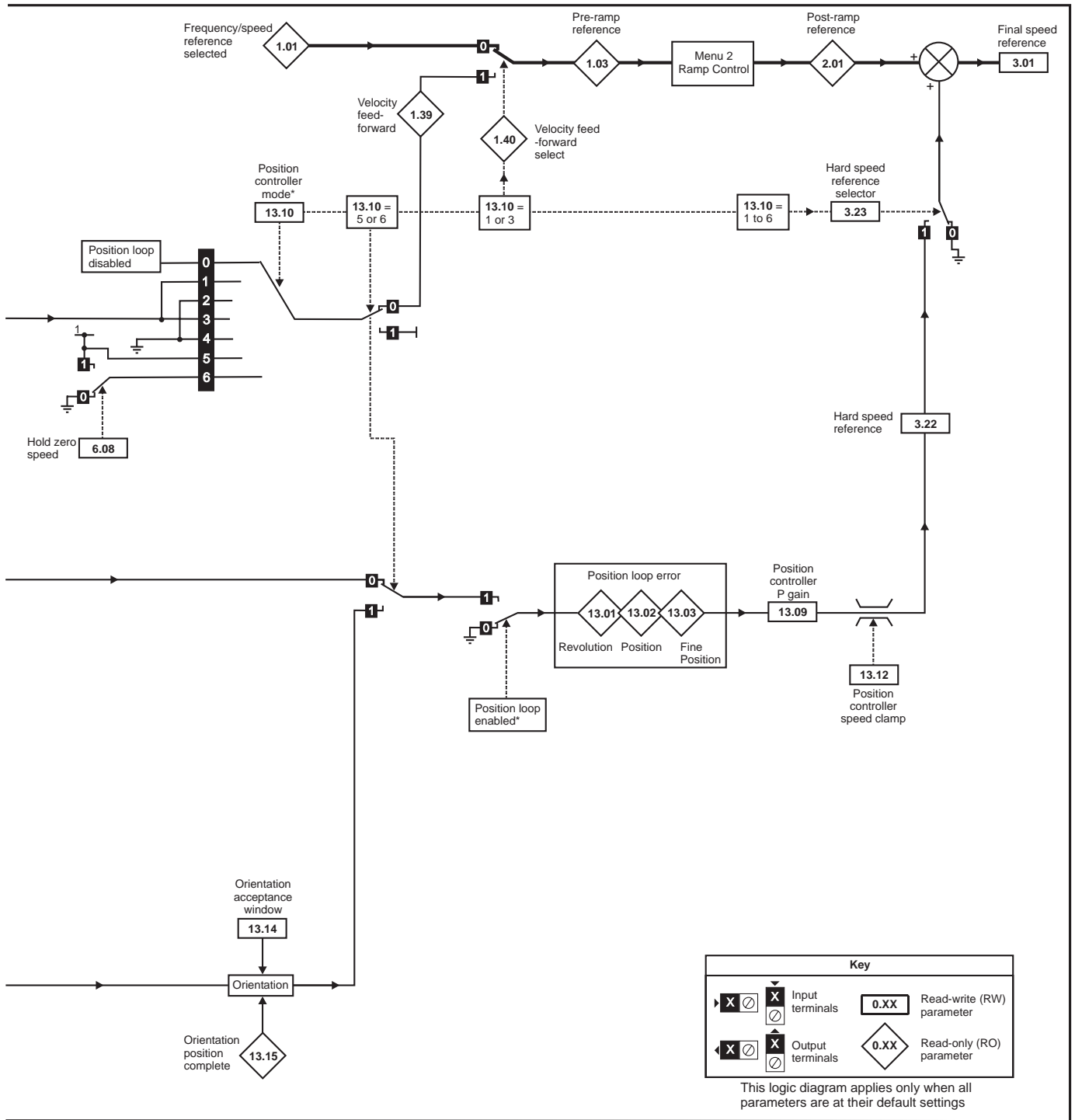


Figure 11-21 Menu 13 Closed-loop logic diagram



\*For more information, refer to section 11.21.9 Position modes on page 255.



\* The position controller is disabled and the error integrator is also reset under the following conditions:

1. If the drive is disabled (i.e. inhibited, ready or tripped)
2. If the position controller mode (Pr 13.10) is changed. The position controller is disabled transiently to reset the error integrator.
3. The absolute mode parameter (Pr 13.11) is changed. The position controller is disabled transiently to reset the error integrator.
4. One of the position sources is invalid.
5. The position feedback initialised parameter (Pr 3.48) is zero.

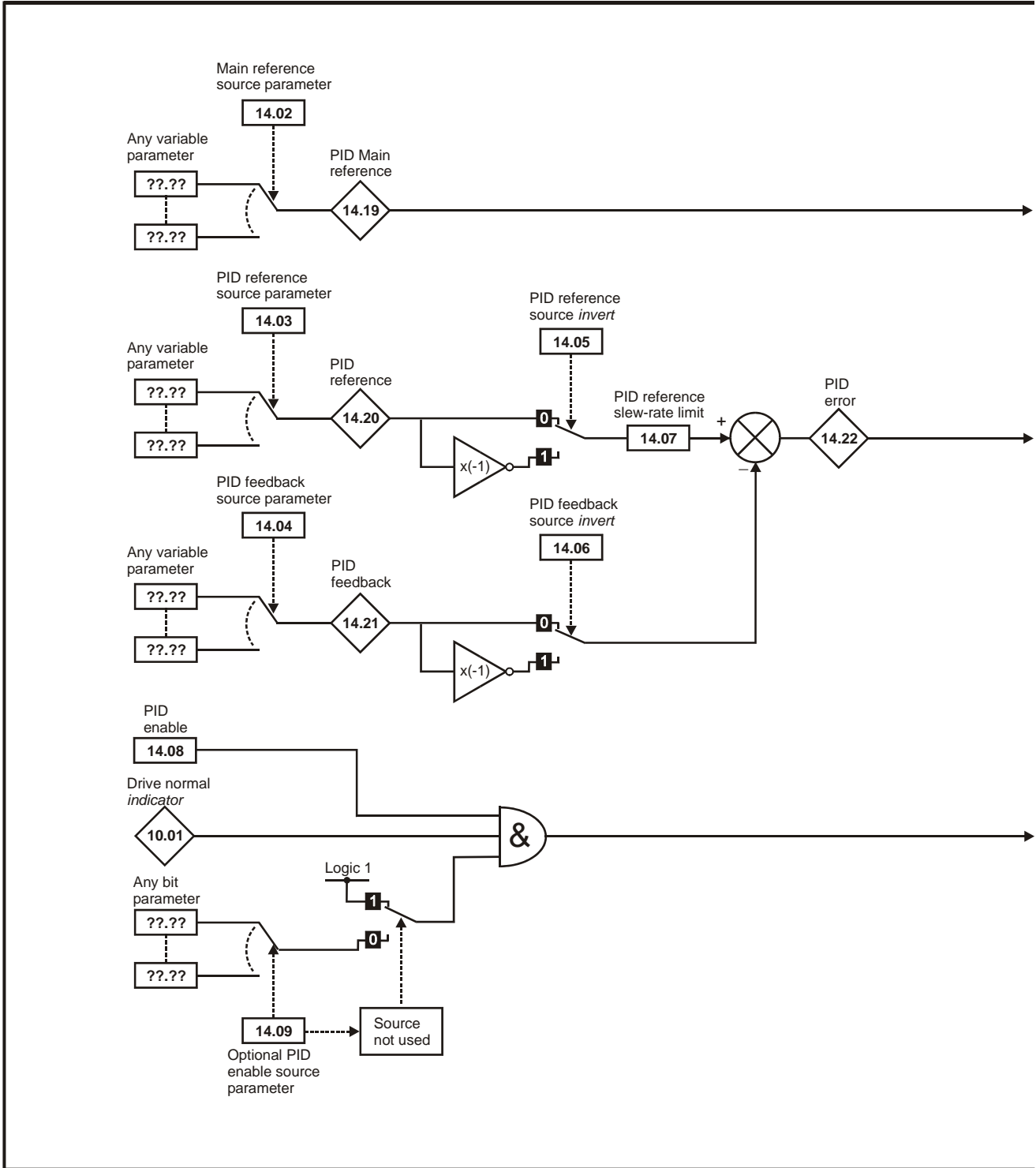
| Parameter |                                      | Range(⇅)  |   | Default(⇨)                       |     |    | Type |     |  |    |    |    |
|-----------|--------------------------------------|---|---|----------------------------------|-----|----|------|-----|--|----|----|----|
|           |                                      | OL  | CL  | OL                               | VT  | SV |      |     |  |    |    |    |
| 13.01     | Revolutions error                    | -32,768 to +32,767  |   |                                  |     |    | RO   | Bi  |  | NC | PT |    |
| 13.02     | Position error                       | -32,768 to +32,767  |   |                                  |     |    | RO   | Uni |  | NC | PT |    |
| 13.03     | Fine position error                  | -32,768 to +32,767  |   |                                  |     |    | RO   | Uni |  | NC | PT |    |
| 13.04     | Position controller reference source | drv (0), Slot1 (1), Slot2 (2), Slot3 (3), LocAL (4)   |   | drv (0)                          |     |    | RW   | Uni |  |    |    | US |
| 13.05     | Position controller feedback source  | drv (0), Slot1 (1), Slot2 (2), Slot3 (3)  |   | drv (0)                          |     |    | RW   | Uni |  |    |    | US |
| 13.06     | Position reference invert            | OFF (0) or On (1)   |   | OFF (0)                          |     |    | RW   | Bit |  |    |    | US |
| 13.07     | Ratio numerator                      | 0.000 to 4.000  |   | 1.000                            |     |    | RW   | Uni |  |    |    | US |
| 13.08     | Ratio denominator                    | 0.000 to 1.000  |   | 1.000                            |     |    | RW   | Uni |  |    |    | US |
| 13.09     | Position controller P gain           | 0.00 to 100.00 rad s <sup>-1</sup> /rad   |   | 25.00                            |     |    | RW   | Uni |  |    |    | US |
| 13.10     | Position controller mode             | Position controller disabled (0)<br>Rigid position control - feed fwd (1)<br>Rigid position control (2) | Position controller disabled (0)<br>Rigid position control - feed fwd (1)<br>Rigid position control (2)<br>Non-rigid position control (2)<br>Non-rigid position control - feed fwd (3)<br>Non-rigid position control (4)<br>Orientation on stop (5)<br>Orientation on stop and when drive enabled (6) | Position controller disabled (0) |     |    | RW   | Uni |  |    |    | US |
| 13.11     | Absolute mode enable                 | OFF (0) or On (1)   |   | OFF (0)                          |     |    | RW   | Bit |  |    |    | US |
| 13.12     | Position controller speed clamp      | 0 to 250  |   | 150                              |     |    | RW   | Uni |  |    |    | US |
| 13.13     | Orientation position reference       |   | 0 to 65,535   |                                  | 0   |    | RW   | Uni |  |    |    | US |
| 13.14     | Orientation acceptance window        |   | 0 to 4,096  |                                  | 256 |    | RW   | Uni |  |    |    | US |
| 13.15     | Orientation position complete        |   | OFF (0) or On (1)   |                                  |     |    | RO   | Bit |  | NC | PT |    |
| 13.16     | Position error reset                 | OFF (0) or On (1)   |   | OFF (0)                          |     |    | RW   | Bit |  | NC |    |    |
| 13.17     | Relative jog reference               | 0.0 to 4,000.0 rpm  |   | 0.0                              |     |    | RW   | Uni |  | NC |    |    |
| 13.18     | Relative jog enable                  | OFF (0) or On (1)   |   | OFF (0)                          |     |    | RW   | Bit |  | NC |    |    |
| 13.19     | Relative jog reverse                 | OFF (0) or On (1)   |   | OFF (0)                          |     |    | RW   | Bit |  | NC |    |    |
| 13.20     | Local reference turns                | 0 to 65,535   |   | 0                                |     |    | RW   | Uni |  | NC |    |    |
| 13.21     | Local reference position             | 0 to 65,535   |   | 0                                |     |    | RW   | Uni |  | NC |    |    |
| 13.22     | Local reference fine position        | 0 to 65,535   |   | 0                                |     |    | RW   | Uni |  | NC |    |    |
| 13.23     | Local reference disable              | OFF (0) or On (1)   |   | OFF (0)                          |     |    | RW   | Bit |  | NC |    |    |
| 13.24     | Ignore local reference turns         | OFF (0) or On (1)   |   | OFF (0)                          |     |    | RW   | Bit |  |    |    | US |

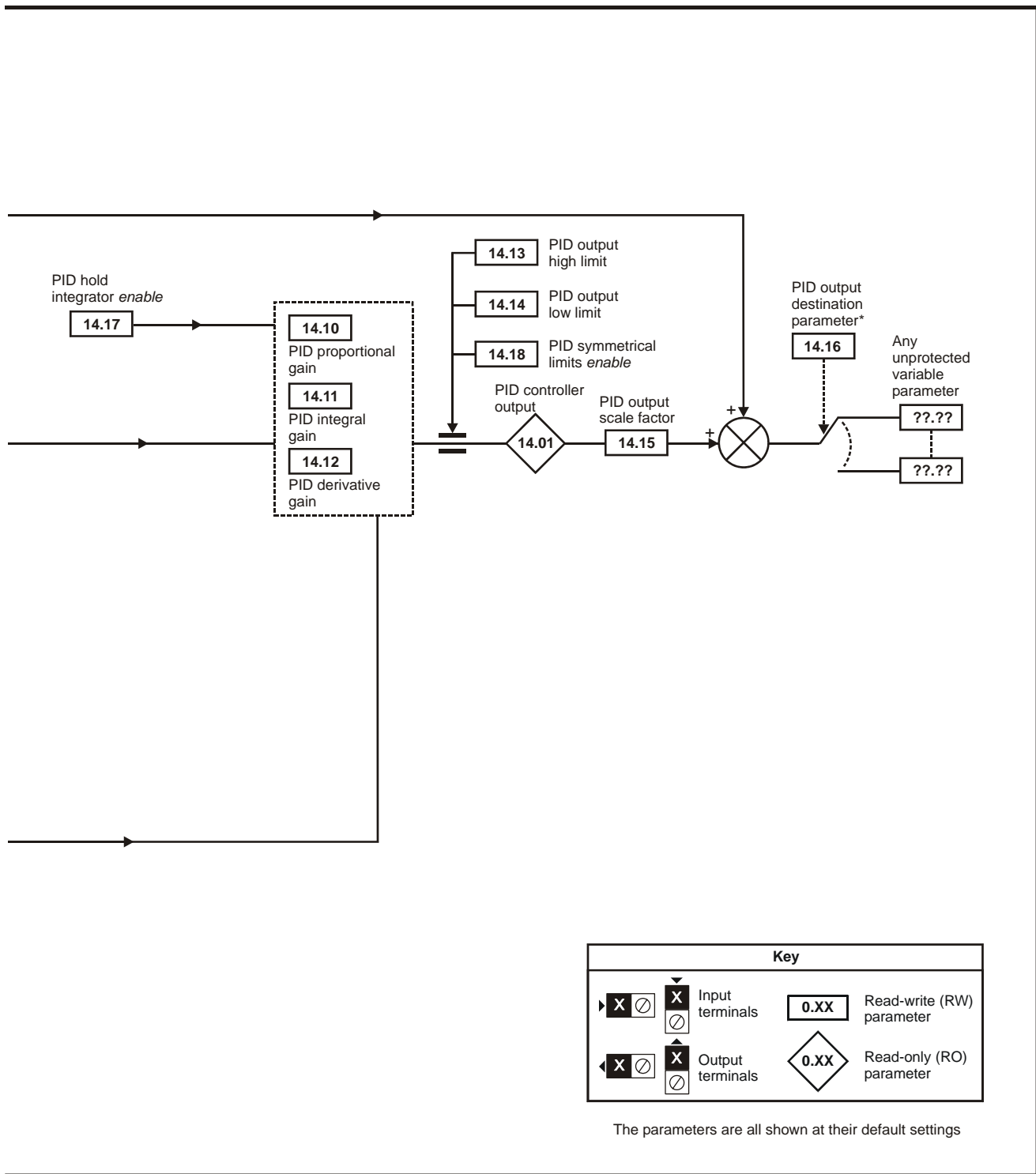
|    |              |    |             |     |            |    |                  |     |               |     |             |    |                 |
|----|--------------|----|-------------|-----|------------|----|------------------|-----|---------------|-----|-------------|----|-----------------|
| RW | Read / Write | RO | Read only   | Uni | Unipolar   | Bi | Bi-polar         | Bit | Bit parameter | Txt | Text string |    |                 |
| FI | Filtered     | DE | Destination | NC  | Not cloned | RA | Rating dependent | PT  | Protected     | US  | User save   | PS | Power down save |



## 11.14 Menu 14: User PID controller

Figure 11-22 Menu 14 Logic diagram





| Key |                           |
|-----|---------------------------|
|     | Input terminals           |
|     | Output terminals          |
|     | Read-write (RW) parameter |
|     | Read-only (RO) parameter  |

The parameters are all shown at their default settings

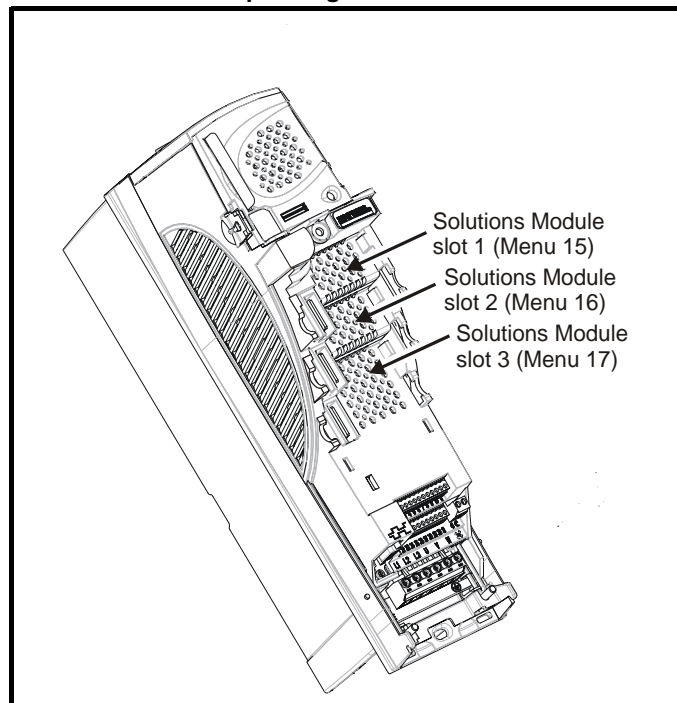
\*The PID controller is only enabled if Pr 14.16 is set to a non Pr xx.00 and unprotected destination parameter.

| Parameter | Range(⇅)          |    | Default(⇨) |    |         | Type |     |    |    |    |    |    |
|-----------|-------------------|----|------------|----|---------|------|-----|----|----|----|----|----|
|           | OL                | CL | OL         | VT | SV      |      |     |    |    |    |    |    |
| 14.01     | ±100.00 %         |    |            |    |         | RO   | Bi  |    | NC | PT |    |    |
| 14.02     | Pr 0.00 to 21.51  |    |            |    | Pr 0.00 | RW   | Uni |    |    |    | PT | US |
| 14.03     | Pr 0.00 to 21.51  |    |            |    | Pr 0.00 | RW   | Uni |    |    |    | PT | US |
| 14.04     | Pr 0.00 to 21.51  |    |            |    | Pr 0.00 | RW   | Uni |    |    |    | PT | US |
| 14.05     | OFF (0) or On (1) |    |            |    | OFF (0) | RW   | Bit |    |    |    |    | US |
| 14.06     | OFF (0) or On (1) |    |            |    | OFF (0) | RW   | Bit |    |    |    |    | US |
| 14.07     | 0.0 to 3,200.0 s  |    |            |    | 0.0     | RW   | Uni |    |    |    |    | US |
| 14.08     | OFF (0) or On (1) |    |            |    | OFF (0) | RW   | Bit |    |    |    |    | US |
| 14.09     | Pr 0.00 to 21.51  |    |            |    | Pr 0.00 | RW   | Uni |    |    |    | PT | US |
| 14.10     | 0.000 to 4.000    |    |            |    | 1.000   | RW   | Uni |    |    |    |    | US |
| 14.11     | 0.000 to 4.000    |    |            |    | 0.500   | RW   | Uni |    |    |    |    | US |
| 14.12     | 0.000 to 4.000    |    |            |    | 0.000   | RW   | Uni |    |    |    |    | US |
| 14.13     | 0.00 to 100.00 %  |    |            |    | 100.00  | RW   | Uni |    |    |    |    | US |
| 14.14     | ±100.00 %         |    |            |    | -100.00 | RW   | Bi  |    |    |    |    | US |
| 14.15     | 0.000 to 4.000    |    |            |    | 1.000   | RW   | Uni |    |    |    |    | US |
| 14.16     | Pr 0.00 to 21.51  |    |            |    | Pr 0.00 | RW   | Uni | DE |    |    | PT | US |
| 14.17     | OFF (0) or On (1) |    |            |    | OFF (0) | RW   | Bit |    | NC |    |    |    |
| 14.18     | OFF (0) or On (1) |    |            |    | OFF (0) | RW   | Bit |    |    |    |    | US |
| 14.19     | ±100.00 %         |    |            |    |         | RO   | Bi  |    | NC | PT |    |    |
| 14.20     | ±100.00 %         |    |            |    |         | RO   | Bi  |    | NC | PT |    |    |
| 14.21     | ±100.00 %         |    |            |    |         | RO   | Bi  |    | NC | PT |    |    |
| 14.22     | ±100.00 %         |    |            |    |         | RO   | Bi  |    | NC | PT |    |    |

|    |              |    |             |     |            |    |                  |     |               |     |             |    |                 |
|----|--------------|----|-------------|-----|------------|----|------------------|-----|---------------|-----|-------------|----|-----------------|
| RW | Read / Write | RO | Read only   | Uni | Unipolar   | Bi | Bi-polar         | Bit | Bit parameter | Txt | Text string |    |                 |
| FI | Filtered     | DE | Destination | NC  | Not cloned | RA | Rating dependent | PT  | Protected     | US  | User save   | PS | Power down save |

## 11.15 Menus 15, 16 and 17: Solutions Module set-up

Figure 11-23 Location of Solutions Module slots and their corresponding menu numbers



### 11.15.1 Parameters common to all categories

| Parameter   | Range(⇅)      |    | Default(⇔) |    |    | Type |     |  |    |    |    |
|---|---------------|----|------------|----|----|------|-----|--|----|----|----|
|   | OL            | CL | OL         | VT | SV |      |     |  |    |    |    |
| <b>x.01</b> Solutions Module ID                   | 0 to 599      |    |            |    |    | RO   | Uni |  |    | PT | US |
| <b>x.02</b> Solutions Module software version     | 0.00 to 99.99 |    |            |    |    | RO   | Uni |  | NC | PT |    |
| <b>x.50</b> Solutions Module error status         | 0 to 255      |    |            |    |    | RO   | Uni |  | NC | PT |    |
| <b>x.51</b> Solutions Module software sub-version | 0 to 99       |    |            |    |    | RO   | Uni |  | NC | PT |    |

The Solutions Module ID indicates the type of module that is fitted in the corresponding slot.

| Solutions Module ID | Module                    | Category   |
|---------------------|---------------------------|------------|
| 0                   | No module fitted          |            |
| 101                 | SM-Resolver               | Feedback   |
| 102                 | SM-Universal Encoder Plus |            |
| 104                 | SM-Encoder Plus           |            |
| 201                 | SM-I/O Plus               | Automation |
| 203                 | SM-I/O Timer              |            |
| 204                 | SM-PELV                   |            |
| 206                 | SM-I/O 120V               |            |
| 207                 | SM-I/O Lite               |            |
| 301                 | SM-Applications           |            |
| 302                 | SM-Applications Lite      |            |
| 303                 | SM-EZMotion               | Fieldbus   |
| 403                 | SM-PROFIBUS-DP            |            |
| 404                 | SM-Interbus               |            |
| 406                 | SM-CAN                    |            |
| 407                 | SM-DeviceNet              |            |
| 408                 | SM-CANopen                |            |
| 409                 | SM-SERCOS                 |            |
| 410                 | SM-Ethernet               |            |
| 501                 | SM-SLM                    | SLM        |

#### Solutions Module software

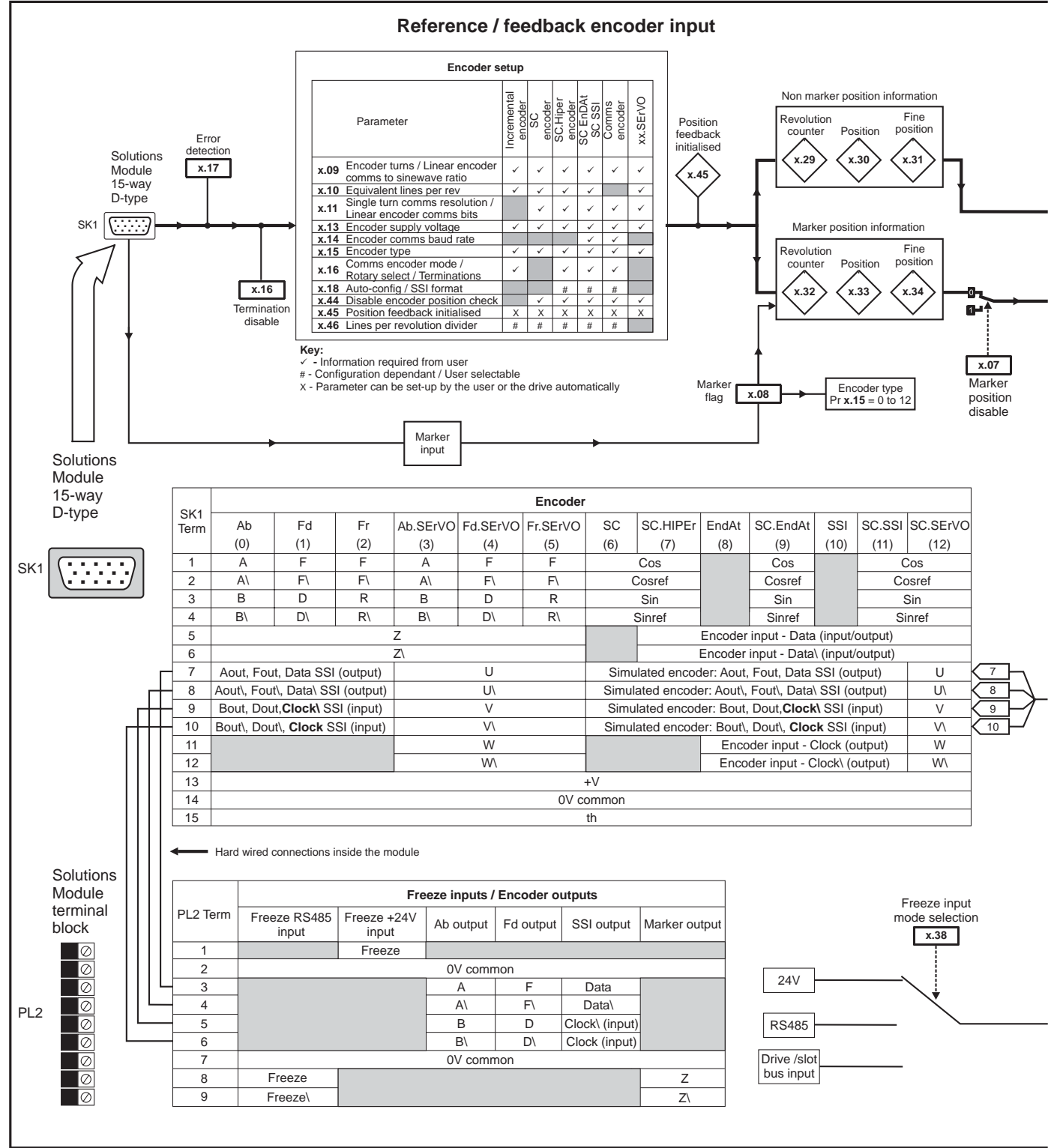
Most Solutions Modules contain software. The software version of the module can be checked by looking at Pr **xx.02** and Pr **xx.51**.

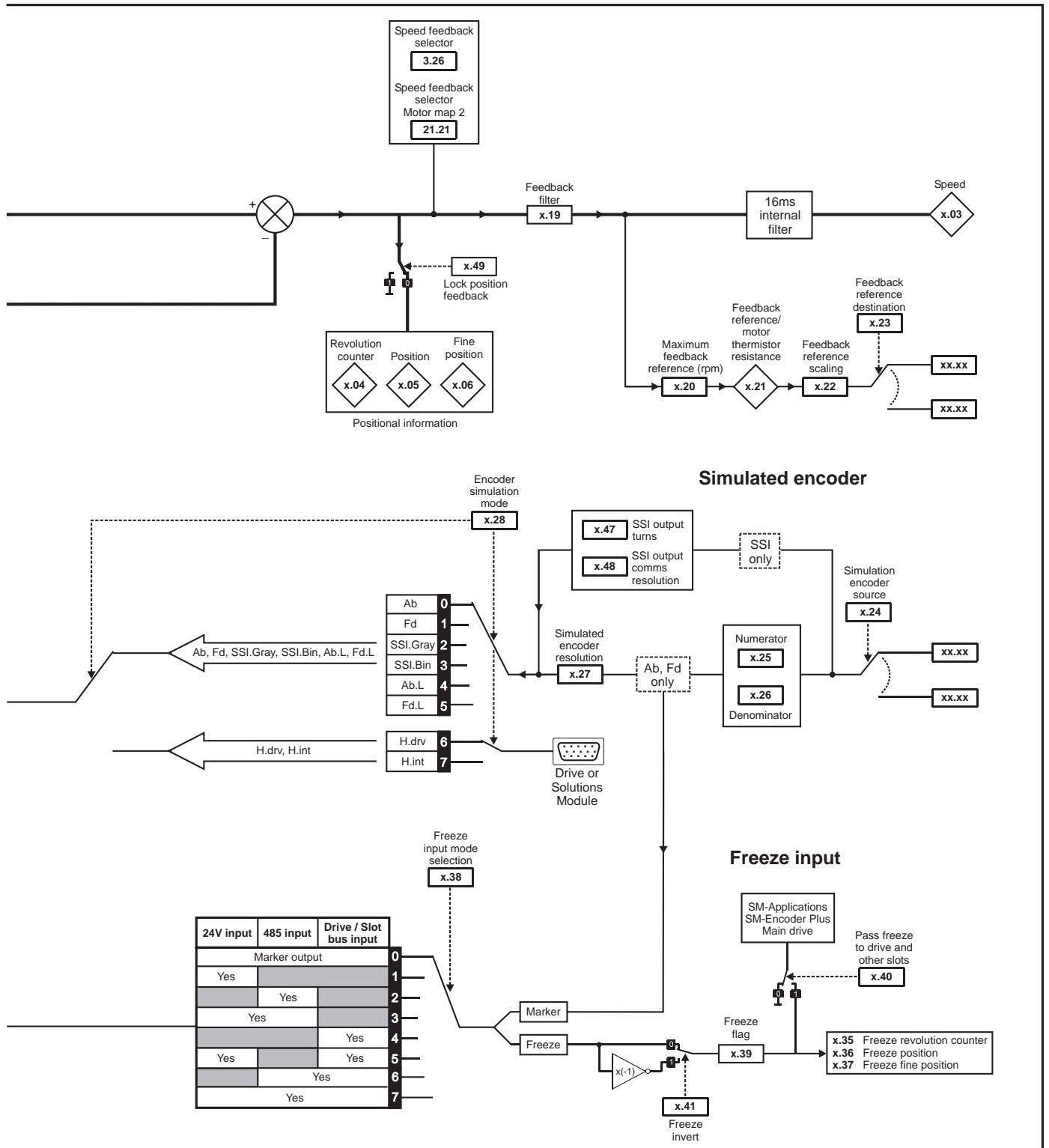
The software version takes the form of zz.yy.xx, where Pr **xx.02** displays zz.yy and Pr **xx.51** displays xx. I.e. for software version 01.01.00, Pr **xx.02** would display 1.01 and Pr **xx.51** would display 0

The SM-Resolver, SM-Encoder Plus and SM-I/O Plus modules do not contain any software, so Pr **xx.02** and Pr **xx.51** either show 0 (software V01.07.01 and earlier) or the parameters do not appear (software V01.08.00 and later).

### 11.15.2 Feedback module category

Figure 11-24 SM-Universal Encoder Plus logic diagram





### SM-Universal Encoder Plus parameters

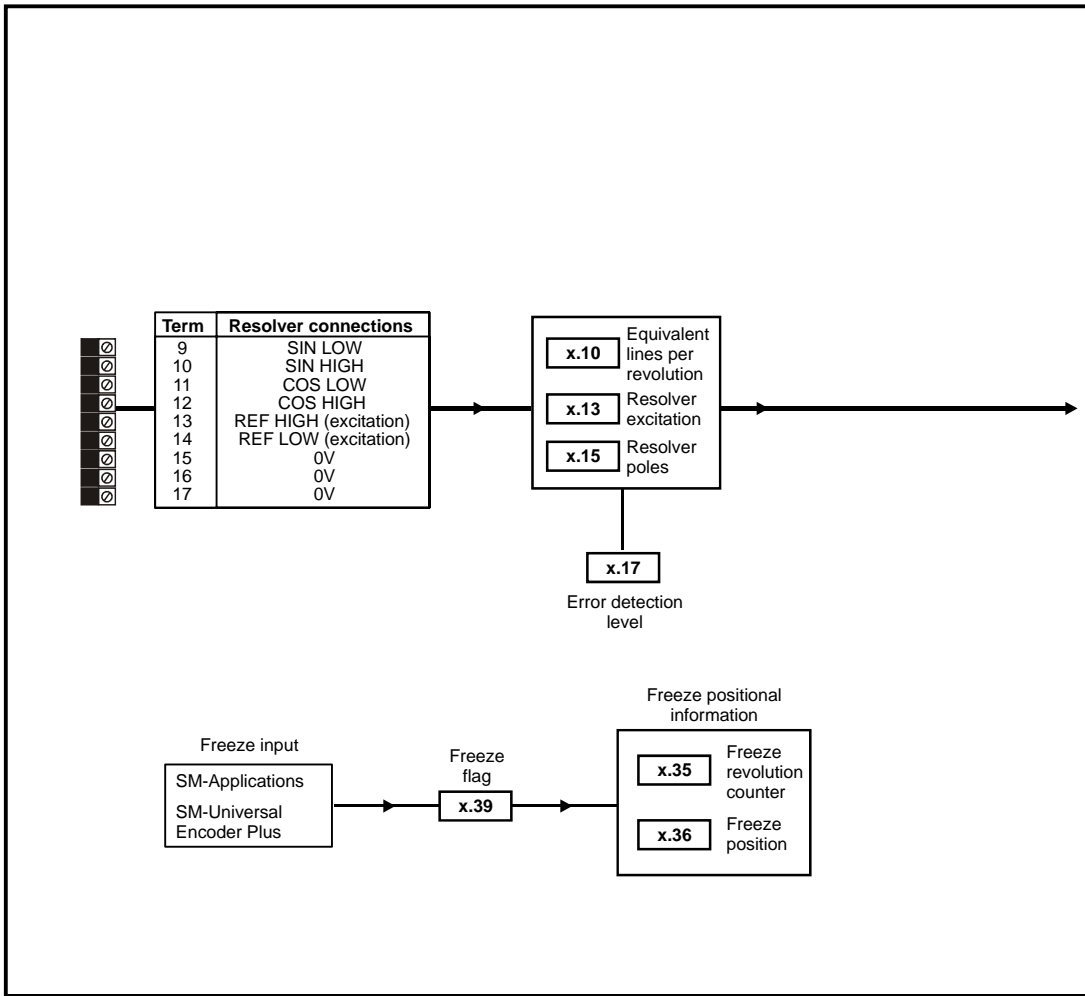
| Parameter   | Range(⇅)  |                     | Default(⇒) |    |    | Type |     |    |    |    |    |
|---|---|---------------------|------------|----|----|------|-----|----|----|----|----|
|   | OL  | CL                  | OL         | VT | SV | RO   | Uni | FI | NC | PT | US |
| x.01 Solutions Module ID  | 0 to 599  |                     | 102        |    |    | RO   | Uni |    |    | PT | US |
| x.02 Solutions Module software version                            | 0.00 to 99.99   |                     |            |    |    | RO   | Uni |    | NC | PT |    |
| x.03 Speed  | ±40,000.0 rpm   |                     |            |    |    | RO   | Bi  | FI | NC | PT |    |
| x.04 Revolution counter   | 0 to 65,535 revolutions   |                     |            |    |    | RO   | Uni | FI | NC | PT |    |
| x.05 Position   | 0 to 65,535 (1/2 <sup>16</sup> ths of a revolution)   |                     |            |    |    | RO   | Uni | FI | NC | PT |    |
| x.06 Fine position  | 0 to 65,535 (1/2 <sup>32</sup> nds of a revolution)   |                     |            |    |    | RO   | Uni | FI | NC | PT |    |
| x.07 Marker position reset disable                                | OFF (0) or On (1)   |                     | OFF (0)    |    |    | RW   | Bit |    |    |    | US |
| x.08 Marker flag  | OFF (0) or On (1)   |                     | OFF (0)    |    |    | RW   | Bit |    | NC |    |    |
| x.09 Encoder turns/ linear encoder comms to sine wave ratio       | 0 to 16 bits  |                     | 16         |    |    | RW   | Uni |    |    |    | US |
| x.10 Equivalent lines per revolution                              | 0 to 50,000   |                     | 4096       |    |    | RW   | Uni |    |    |    | US |
| x.11 Single turn comms bits/ linear encoder comms bits            | 0 to 32 bits  |                     | 0          |    |    | RW   | Uni |    |    |    | US |
| x.12 Motor thermistor check <i>enable</i>                         | OFF (0) or On (1)   |                     | OFF (0)    |    |    | RW   | Bit |    |    |    | US |
| x.13 Encoder supply voltage                                       | 5V (0), 8V (1), 15V (2)   |                     | 5V (0)     |    |    | RW   | Uni |    |    |    | US |
| x.14 Encoder comms baud rate                                      | 100 (0), 200 (1), 300 (2), 400 (3), 500 (4), 1,000 (5), 1,500 (6), 2,000 (7)  |                     | 300 (2)    |    |    | RW   | Txt |    |    |    | US |
| x.15 Encoder type   | Ab (0), Fd (1), Fr (2), Ab.SErVO (3), Fd.SErVO (4), Fr.SErVO (5), SC (6), SC.HiPEr (7), EndAt (8), SC.EndAt (9), SSI (10), SC.SSI (11), SC.UVW (12) |                     | Ab (0)     |    |    | RW   | Uni |    |    |    | US |
| x.16 Rotary encoder select/ comms only encoder mode/ terminations | 0 to 2  |                     | 1          |    |    | RW   | Uni |    |    |    | US |
| x.17 Error detection level  | 0 to 7  |                     | 1          |    |    | RW   | Uni |    |    |    | US |
| x.18 Auto configuration/ SSI binary format select                 | OFF (0) or On (1)   |                     | OFF (0)    |    |    | RW   | Bit |    |    |    | US |
| x.19 Feedback filter  |   | 0 to 5 (0 to 16 ms) | 0          |    |    | RW   | Uni |    |    |    | US |
| x.20 Maximum feedback reference                                   | 0.0 to 40,000.0 rpm   |                     | 1500.0     |    |    | RW   | Uni |    |    |    | US |
| x.21 Feedback reference/ motor thermistor resistance              | ±100.0 %  |                     |            |    |    | RO   | Bi  |    | NC | PT |    |
| x.22 Feedback reference scaling                                   | 0.000 to 4.000  |                     | 1.000      |    |    | RW   | Uni |    |    |    | US |
| x.23 Feedback reference destination                               | Pr 0.00 to Pr 21.51   |                     | Pr 0.00    |    |    | RW   | Uni | DE |    | PT | US |
| x.24 Encoder simulation source                                    | Pr 0.00 to Pr 21.51   |                     | Pr 0.00    |    |    | RW   | Uni |    |    | PT | US |
| x.25 Encoder simulation ratio numerator                           | 0.0000 to 3.0000  |                     | 0.2500     |    |    | RW   | Uni |    |    |    | US |
| x.26 Encoder simulation ratio denominator                         | 0.0000 to 3.0000  |                     | 1.0000     |    |    | RW   | Uni |    |    |    | US |
| x.27 Encoder simulation resolution select                         | OFF (0) or On (1)   |                     | OFF (0)    |    |    | RW   | Bit |    | NC |    |    |
| x.28 Encoder simulation mode                                      | Ab (0), Fd (1), SSI.Gray (2), SSI.Bin (3), Ab.L (4), Fd.L (5), H-drv (6), H-int (7)   |                     | Ab (0)     |    |    | RW   | Txt |    |    |    | US |
| x.29 Non-marker reset revolution counter                          | 0 to 65,535 revolutions   |                     |            |    |    | RO   | Uni |    | NC | PT |    |
| x.30 Non-marker reset position                                    | 0 to 65,535 (1/2 <sup>16</sup> ths of a revolution)   |                     |            |    |    | RO   | Uni |    | NC | PT |    |
| x.31 Non-marker reset fine position                               | 0 to 65,535 (1/2 <sup>32</sup> nds of a revolution)   |                     |            |    |    | RO   | Uni |    | NC | PT |    |
| x.32 Marker revolution counter                                    | 0 to 65,535 revolutions   |                     |            |    |    | RO   | Uni |    | NC | PT |    |
| x.33 Marker position  | 0 to 65,535 (1/2 <sup>16</sup> ths of a revolution)   |                     |            |    |    | RO   | Uni |    | NC | PT |    |
| x.34 Marker fine position   | 0 to 65,535 (1/2 <sup>32</sup> nds of a revolution)   |                     |            |    |    | RO   | Uni |    | NC | PT |    |
| x.35 Freeze revolution counter                                    | 0 to 65,535 revolutions   |                     |            |    |    | RO   | Uni |    | NC | PT |    |
| x.36 Freeze position  | 0 to 65,535 (1/2 <sup>16</sup> ths of a revolution)   |                     |            |    |    | RO   | Uni |    | NC | PT |    |
| x.37 Freeze fine position   | 0 to 65,535 (1/2 <sup>32</sup> nds of a revolution)   |                     |            |    |    | RO   | Uni |    | NC | PT |    |
| x.38 Freeze input mode selection                                  | Bit 0 (LSB) = 24V input<br>Bit 1 = EI485 input<br>Bit 2 (MSB) = From another Solutions Module   |                     | 1          |    |    | RW   | Uni |    |    |    | US |
| x.39 Freeze flag  | OFF (0) or On (1)   |                     | OFF (0)    |    |    | RW   | Bit |    | NC |    |    |
| x.40 Pass freeze to drive and other slots                         | OFF (0) or On (1)   |                     | OFF (0)    |    |    | RW   | Bit |    | NC |    | US |
| x.41 Freeze invert  | OFF (0) or On (1)   |                     | OFF (0)    |    |    | RW   | Bit |    |    |    | US |
| x.42 Encoder comms transmit register/ Sin signal value            | 0 to 65,535   |                     | 0          |    |    | RW   | Uni |    | NC |    |    |
| x.43 Encoder comms receive register/ Cos signal value             | 0 to 65,535   |                     | 0          |    |    | RW   | Uni |    | NC |    |    |
| x.44 Disable encoder position check                               | OFF (0) or On (1)   |                     | OFF (0)    |    |    | RW   | Bit |    | NC |    |    |
| x.45 Position feedback initialised                                | OFF (0) or On (1)   |                     |            |    |    | RO   | Bit |    | NC | PT |    |
| x.46 Lines per revolution divider                                 | 1 to 1024   |                     | 1          |    |    | RW   | Uni |    |    |    | US |
| x.47 SSI output turns   | 0 to 16 bits  |                     | 16         |    |    | RW   | Uni |    |    |    | US |
| x.48 SSI output comms resolution                                  | 0 to 32 bits  |                     | 0          |    |    | RW   | Uni |    |    |    | US |
| x.49 Lock position feedback                                       | OFF (0) or On (1)   |                     | OFF (0)    |    |    | RW   | Bit |    |    |    |    |
| x.50 Solutions Module error status*                               | 0 to 255  |                     |            |    |    | RO   | Uni |    | NC | PT |    |
| x.51 Solutions Module software sub-version                        | 0 to 99   |                     |            |    |    | RO   | Uni |    | NC | PT |    |

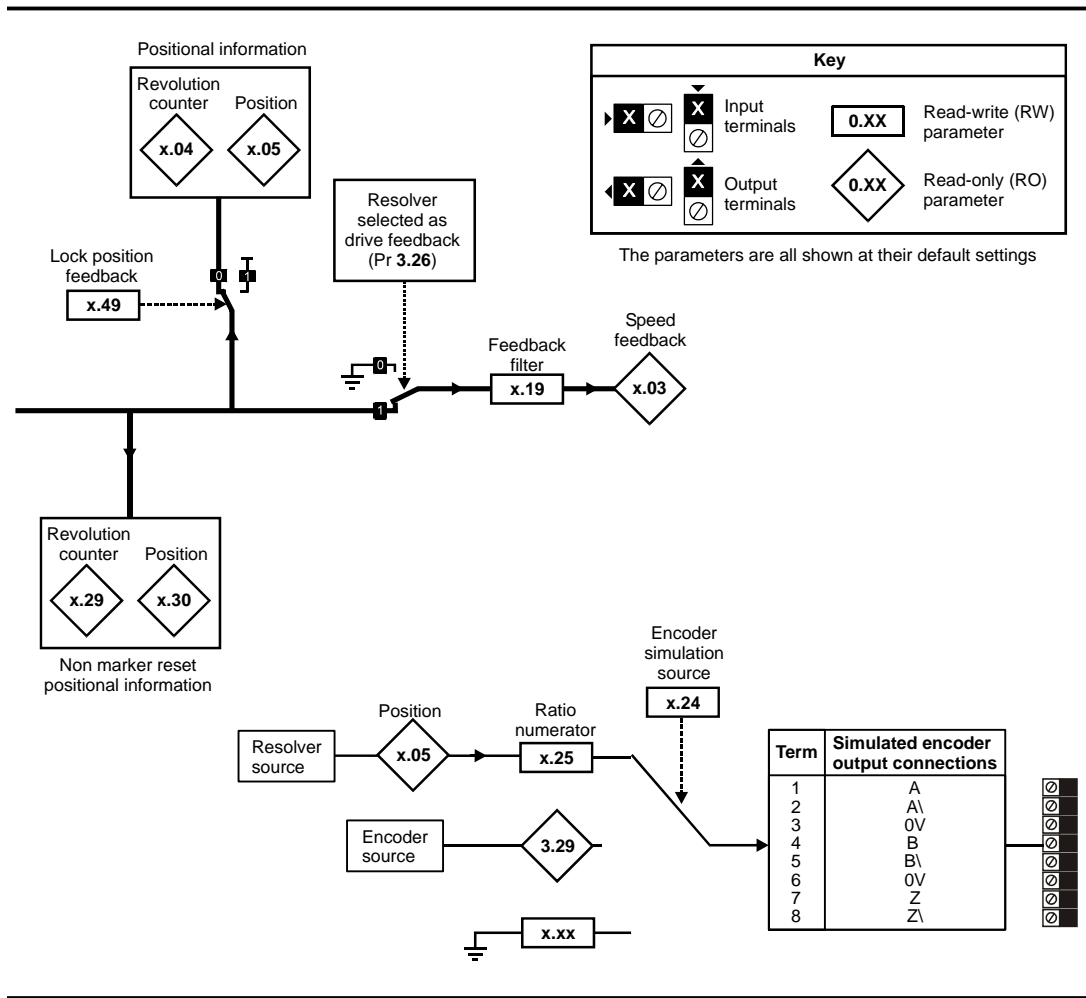
|    |              |    |             |     |            |    |                  |     |               |     |             |    |                 |
|----|--------------|----|-------------|-----|------------|----|------------------|-----|---------------|-----|-------------|----|-----------------|
| RW | Read / Write | RO | Read only   | Uni | Unipolar   | Bi | Bi-polar         | Bit | Bit parameter | Txt | Text string |    |                 |
| FI | Filtered     | DE | Destination | NC  | Not cloned | RA | Rating dependent | PT  | Protected     | US  | User save   | PS | Power down save |

\*See trip SLX.Er, *Feedback module category* on page 284.



Figure 11-25 SM-Resolver logic diagram





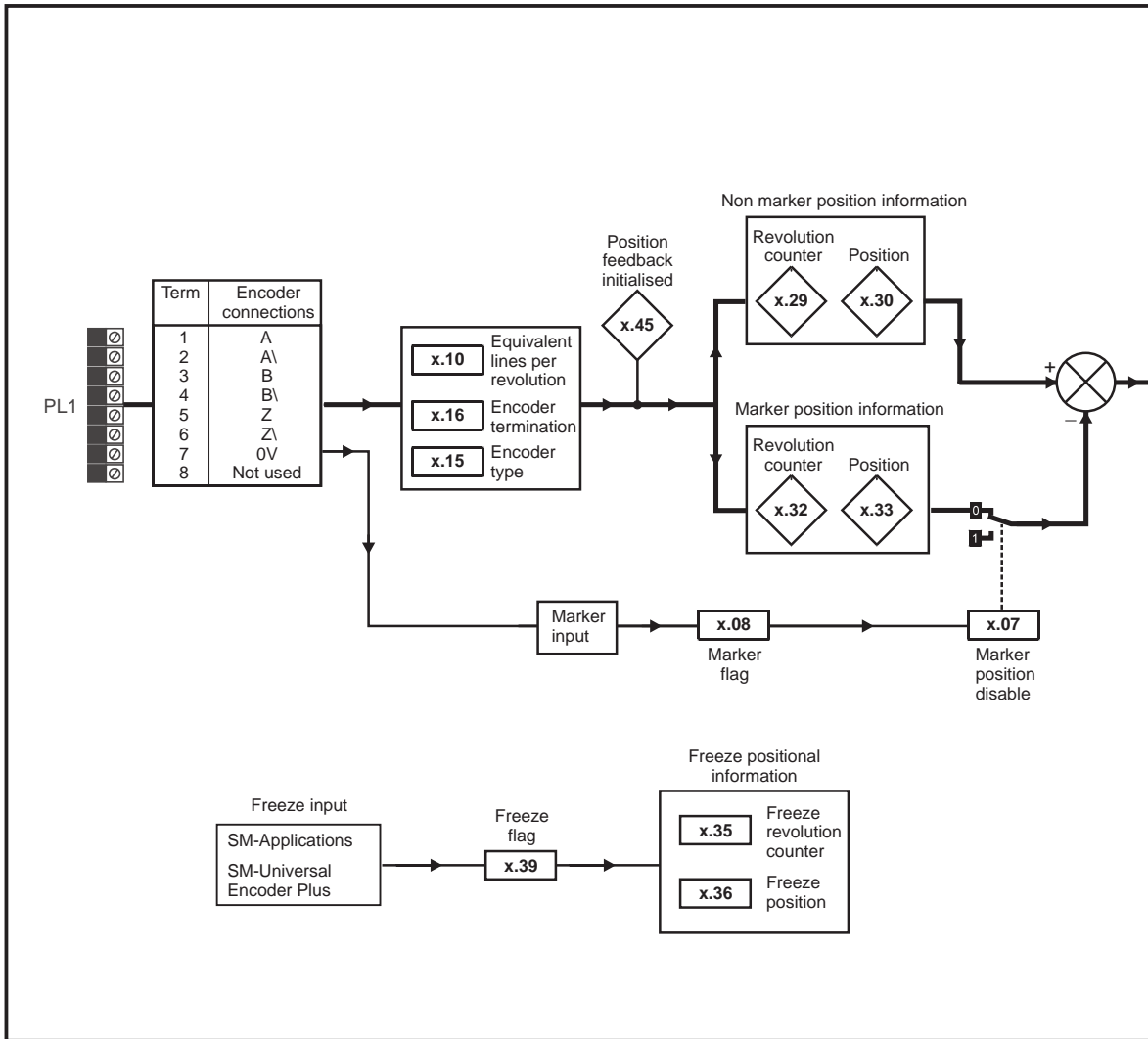
**SM-Resolver parameters**

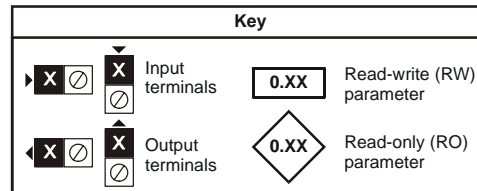
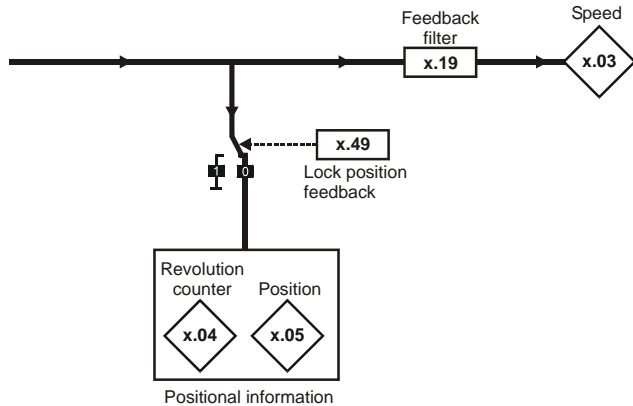
| Parameter                                | Range(↕)   |    | Default(⇔) |    |    | Type |     |    |    |    |    |
|--|--|----|------------|----|----|------|-----|----|----|----|----|
|  | OL   | CL | OL         | VT | SV |      |     |    |    |    |    |
| x.01 Solutions Module ID                 | 0 to 599   |    | 101        |    |    | RO   | Uni |    |    | PT | US |
| x.03 Speed                               | ±40,000.0 rpm  |    |            |    |    | RO   | Bi  | FI | NC | PT |    |
| x.04 Revolution counter                  | 0 to 65,535 revolutions  |    |            |    |    | RO   | Uni | FI | NC | PT |    |
| x.05 Position                            | 0 to 65,535 1/2 <sup>16</sup> ths of a revolution  |    |            |    |    | RO   | Uni | FI | NC | PT |    |
| x.10 Equivalent lines per revolution     | 0 to 50,000  |    | 4096       |    |    | RW   | Uni |    |    |    | US |
| x.13 Resolver excitation                 | 3:1 (0), 2:1 (1 or 2)  |    | 3:1 (0)    |    |    | RW   | Uni |    |    |    | US |
| x.15 Resolver poles                      | 2 pole (0), 4 pole (1), 6 pole (2), 8 pole (3 to 11)   |    | 2 pole (0) |    |    | RW   | Uni |    |    |    | US |
| x.17 Error detection level               | Bit 0 (LSB) = Wire break detect<br>Bit 1 = Phase error detect<br>Bit 2 (MSB) = SSI power supply bit monitor<br>Value is binary sum |    | 1          |    |    | RW   | Uni |    |    |    | US |
| x.19 Feedback filter                     | 0 (0), 1 (1), 2 (2), 4 (3), 8 (4), 16 (5) ms   |    | 0          |    |    | RW   | Txt |    |    |    | US |
| x.24 Encoder simulation source           | Pr 0.00 to Pr 21.51  |    | Pr 0.00    |    |    | RW   | Uni |    |    | PT | US |
| x.25 Encoder simulation ratio numerator  | 0.0000 to 3.0000   |    | 0.25       |    |    | RW   | Uni |    |    |    | US |
| x.29 Non-marker reset revolution counter | 0 to 65,535 revolutions  |    |            |    |    | RO   | Uni | NC |    | PT |    |
| x.30 Non-marker reset position           | 0 to 65,535 1/2 <sup>16</sup> ths of a revolution  |    |            |    |    | RO   | Uni | NC |    | PT |    |
| x.35 Freeze revolution counter           | 0 to 65,535 revolutions  |    |            |    |    | RO   | Uni | NC |    | PT |    |
| x.36 Freeze position                     | 0 to 65,535 1/2 <sup>16</sup> ths of a revolution  |    |            |    |    | RO   | Uni | NC |    | PT |    |
| x.39 Freeze flag                         | OFF (0) or On (1)  |    | OFF (0)    |    |    | RW   | Bit |    | NC |    |    |
| x.45 Position feedback initialised       | OFF (0) or On (1)  |    |            |    |    | RO   | Bit |    | NC | PT |    |
| x.49 Lock position feedback              | OFF (0) or On (1)  |    | OFF (0)    |    |    | RW   | Bit |    | NC |    |    |
| x.50 Solutions Module error status*      | 0 to 255   |    |            |    |    | RO   | Uni | NC |    | PT |    |

|    |              |    |             |     |            |    |                  |     |               |     |             |    |                 |
|----|--------------|----|-------------|-----|------------|----|------------------|-----|---------------|-----|-------------|----|-----------------|
| RW | Read / Write | RO | Read only   | Uni | Unipolar   | Bi | Bi-polar         | Bit | Bit parameter | Txt | Text string |    |                 |
| FI | Filtered     | DE | Destination | NC  | Not cloned | RA | Rating dependent | PT  | Protected     | US  | User save   | PS | Power down save |

\*See trip SLX.Er, Feedback module category on page 284.

Figure 11-26 SM-Encoder Plus logic diagram





The parameters are all shown at their default settings

**SM-Encoder Plus parameters**

| Parameter                                | Range(↕)  |    | Default(⇔) |    |    | Type |     |    |    |    |    |
|--|---|----|------------|----|----|------|-----|----|----|----|----|
|  | OL  | CL | OL         | VT | SV | RO   | Uni | FI | NC | PT | US |
| x.01 Solutions Module ID                 | 0 to 599  |    | 101        |    |    | RO   | Uni |    |    | PT | US |
| x.03 Speed                               | ±40,000.0 rpm                                     |    |            |    |    | RO   | Bi  | FI | NC | PT |    |
| x.04 Revolution counter                  | 0 to 65,535 revolutions                           |    |            |    |    | RO   | Uni | FI | NC | PT |    |
| x.05 Position                            | 0 to 65,535 1/2 <sup>16</sup> ths of a revolution |    |            |    |    | RO   | Uni | FI | NC | PT |    |
| x.07 Marker position reset disable       | OFF (0) or On (1)                                 |    | OFF (0)    |    |    | RW   | Bit |    |    |    | US |
| x.08 Marker flag                         | OFF (0) or On (1)                                 |    | OFF (0)    |    |    | RW   | Bit |    | NC |    |    |
| x.10 Equivalent lines per revolution     | 0 to 50,000                                       |    | 4096       |    |    | RW   | Uni |    |    |    | US |
| x.15 Encoder type                        | Ab (0), Fd (1), Fr (2),                           |    | AB (0)     |    |    | RW   | Uni |    |    |    | US |
| x.16 Encoder termination                 | 0 to 2  |    | 1          |    |    | RW   | Uni |    |    |    | US |
| x.19 Feedback filter                     | 0 (0), 1 (1), 2 (2), 4 (3), 8 (4), 16 (5) ms      |    | 0          |    |    | RW   | Txt |    |    |    | US |
| x.29 Non-marker reset revolution counter | 0 to 65,535 revolutions                           |    |            |    |    | RO   | Uni |    | NC | PT |    |
| x.30 Non-marker reset position           | 0 to 65,535 1/2 <sup>16</sup> ths of a revolution |    |            |    |    | RO   | Uni |    | NC | PT |    |
| x.32 Marker revolution counter           | 0 to 65,535 revolutions                           |    |            |    |    | RO   | Uni |    | NC | PT |    |
| x.33 Marker position                     | 0 to 65,535 1/2 <sup>16</sup> ths of a revolution |    |            |    |    | RO   | Uni |    | NC | PT |    |
| x.35 Freeze revolution counter           | 0 to 65,535 revolutions                           |    |            |    |    | RO   | Uni |    | NC | PT |    |
| x.36 Freeze position                     | 0 to 65,535 1/2 <sup>16</sup> ths of a revolution |    |            |    |    | RO   | Uni |    | NC | PT |    |
| x.39 Freeze flag                         | OFF (0) or On (1)                                 |    | OFF (0)    |    |    | RW   | Bit |    | NC |    |    |
| x.45 Position feedback initialised       | OFF (0) or On (1)                                 |    |            |    |    | RO   | Bit |    | NC | PT |    |
| x.49 Lock position feedback              | OFF (0) or On (1)                                 |    | OFF (0)    |    |    | RW   | Bit |    | NC |    |    |
| x.50 Solutions Module error status*      | 0 to 255  |    |            |    |    | RO   | Uni |    | NC | PT |    |

|    |              |    |             |     |            |    |                  |     |               |     |             |    |                 |
|----|--------------|----|-------------|-----|------------|----|------------------|-----|---------------|-----|-------------|----|-----------------|
| RW | Read / Write | RO | Read only   | Uni | Unipolar   | Bi | Bi-polar         | Bit | Bit parameter | Txt | Text string |    |                 |
| FI | Filtered     | DE | Destination | NC  | Not cloned | RA | Rating dependent | PT  | Protected     | US  | User save   | PS | Power down save |

\*See trip SLX.Er, Feedback module category on page 284.

### 11.15.3 Automation module category

Figure 11-27 SM-I/O Plus analogue logic diagram

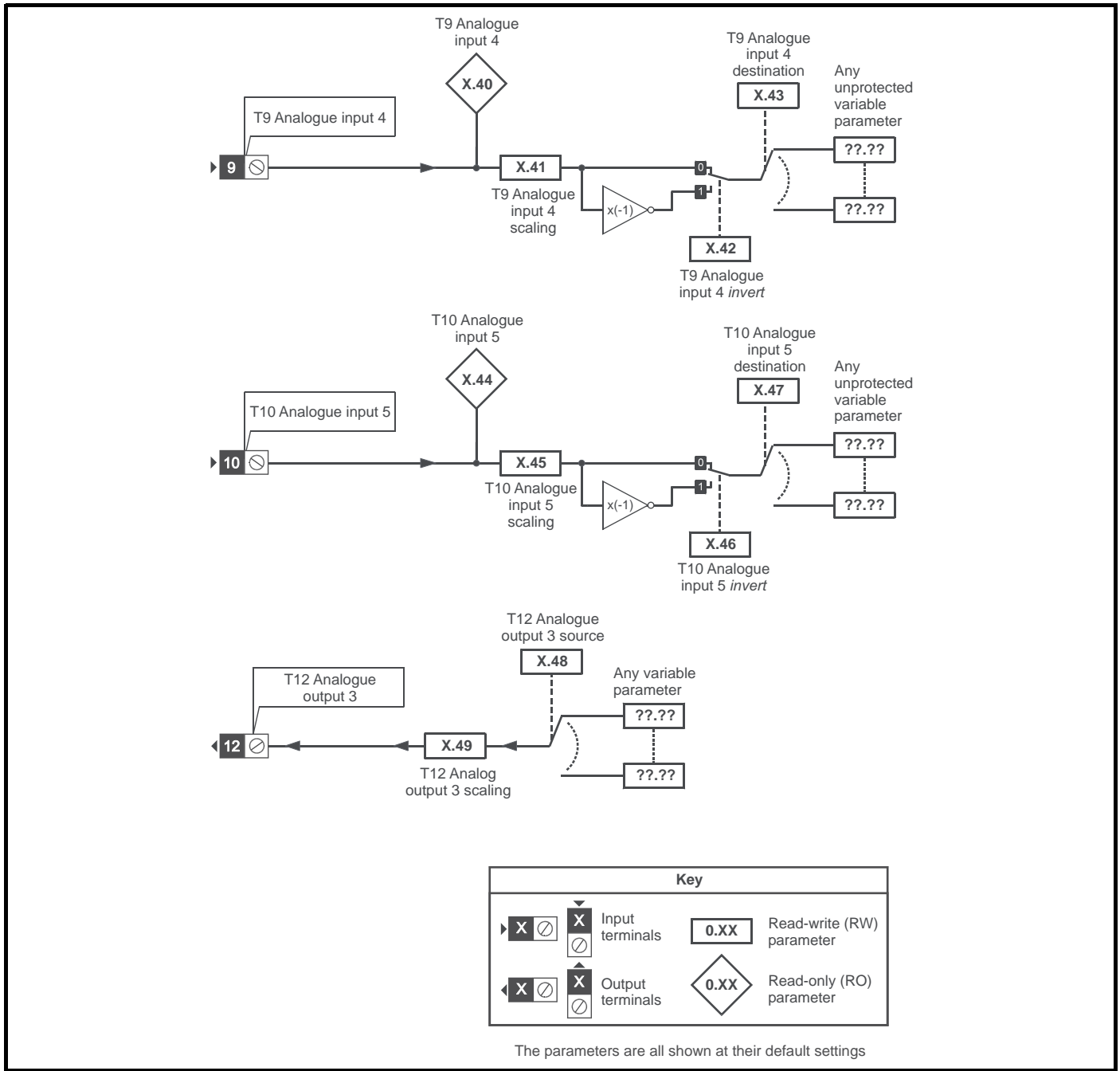


Figure 11-28 SM-I/O Plus digital logic diagram 1

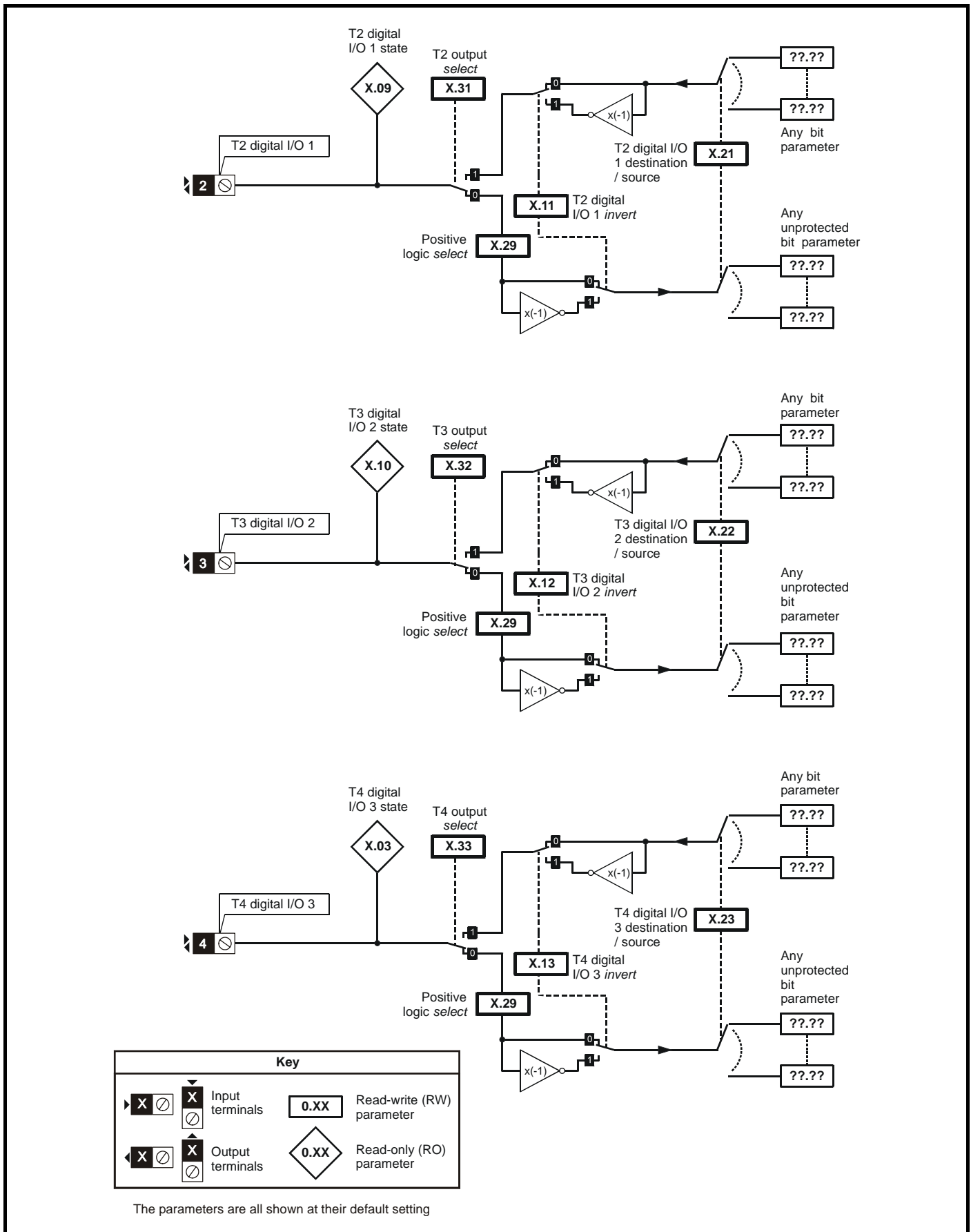
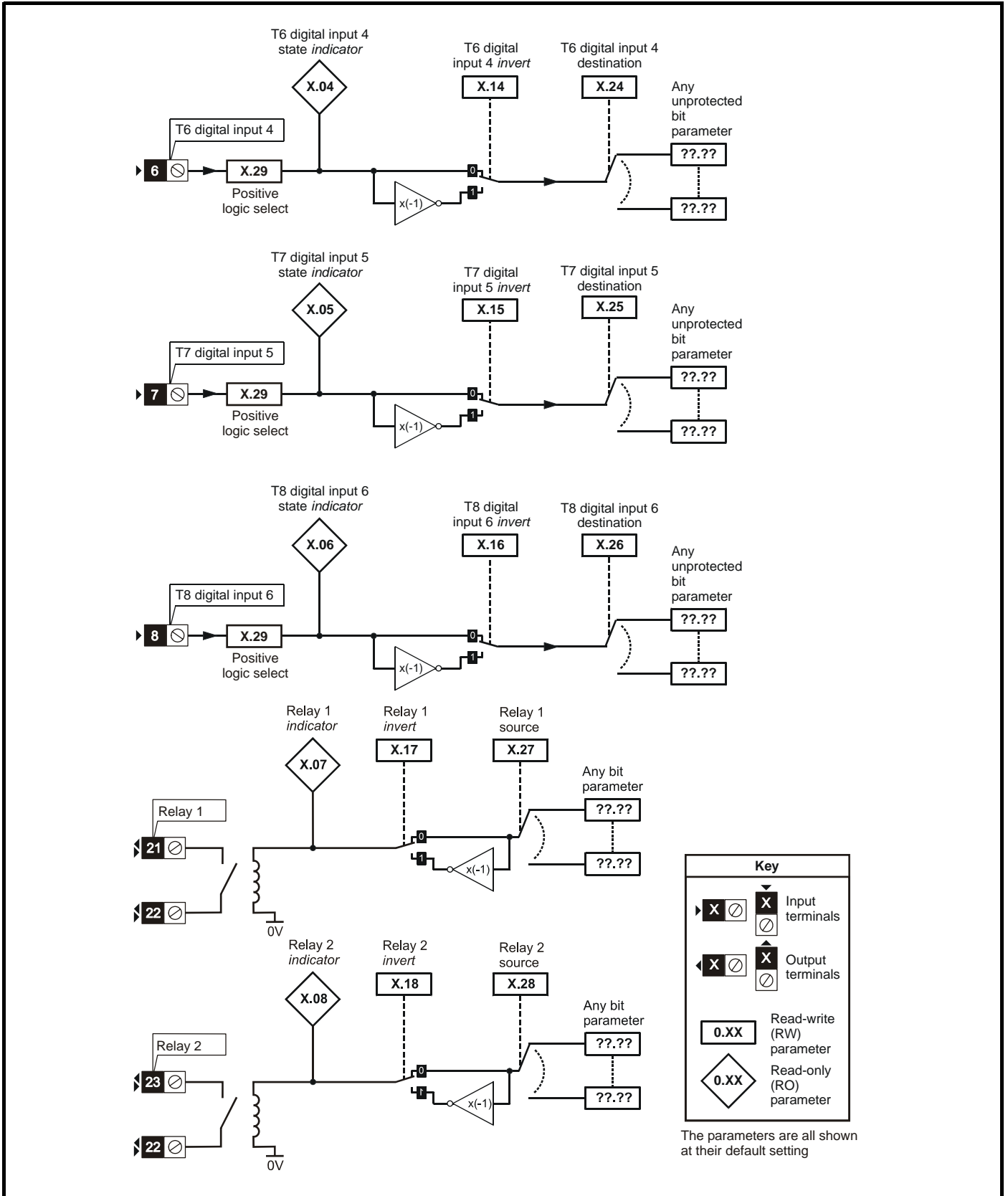


Figure 11-29 SM-I/O Plus digital logic diagram 2



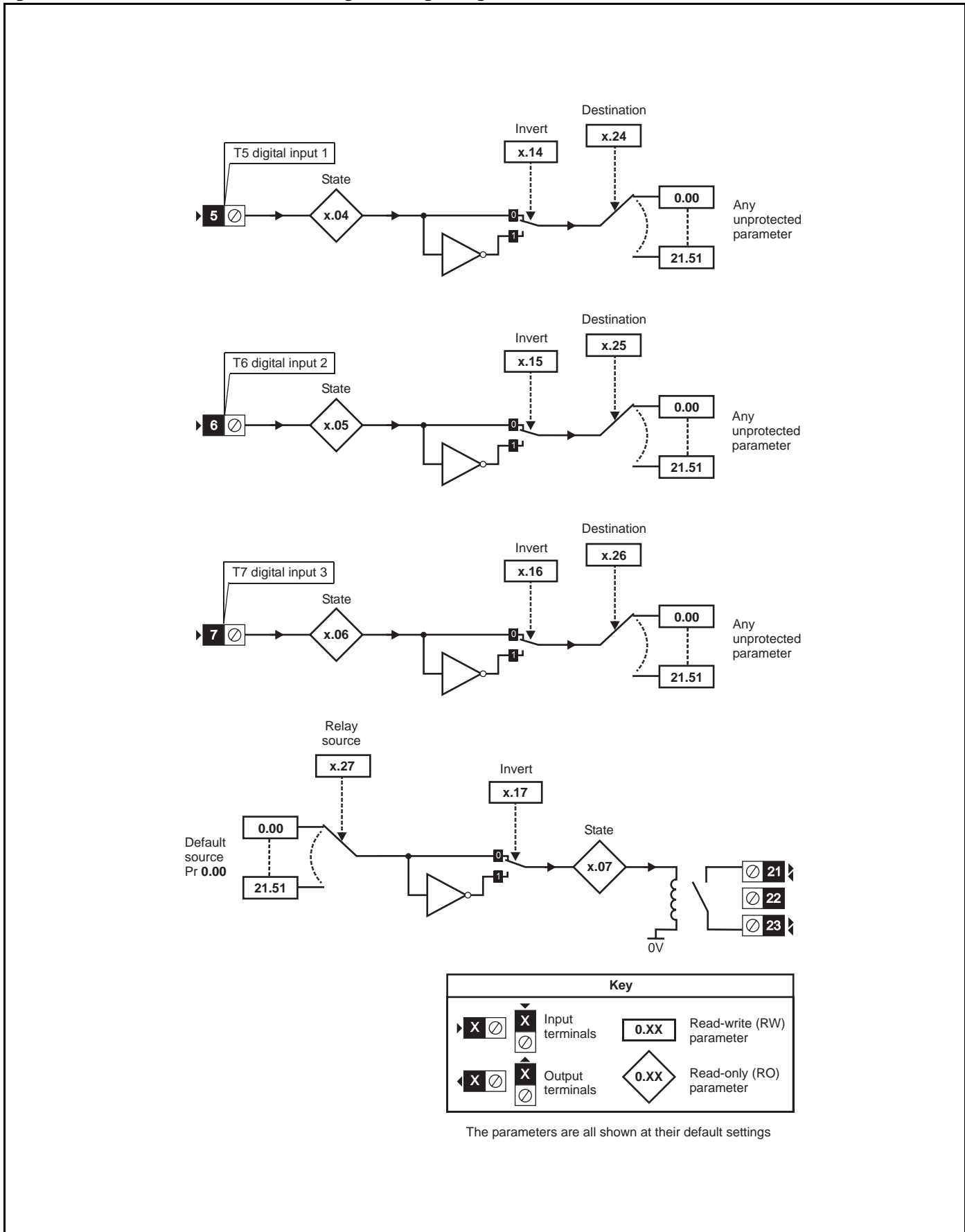
### SM-I/O Plus parameters

| Parameter | Range(⇅)                                |                     | Default(⇔) |                         |    | Type |     |    |    |    |    |
|-----------|---|---------------------|------------|-------------------------|----|------|-----|----|----|----|----|
|           | OL                                      | CL                  | OL         | VT                      | SV |      |     |    |    |    |    |
| x.01      | Solutions Module ID                     | 0 to 599            |            | 201                     |    | RO   | Uni |    |    | PT | US |
| x.03      | T4 digital I/O 3 state                  | OFF (0) or On (1)   |            |                         |    | RO   | Bit |    | NC | PT |    |
| x.04      | T6 digital input 4 state                | OFF (0) or On (1)   |            |                         |    | RO   | Bit |    | NC | PT |    |
| x.05      | T7 digital input 5 state                | OFF (0) or On (1)   |            |                         |    | RO   | Bit |    | NC | PT |    |
| x.06      | T8 digital input 6 state                | OFF (0) or On (1)   |            |                         |    | RO   | Bit |    | NC | PT |    |
| x.07      | Relay 1 state                           | OFF (0) or On (1)   |            |                         |    | RO   | Bit |    | NC | PT |    |
| x.08      | Relay 2 state                           | OFF (0) or On (1)   |            |                         |    | RO   | Bit |    | NC | PT |    |
| x.09      | T2 digital I/O 1 state                  | OFF (0) or On (1)   |            |                         |    | RO   | Bit |    | NC | PT |    |
| x.10      | T3 digital I/O 2 state                  | OFF (0) or On (1)   |            |                         |    | RO   | Bit |    | NC | PT |    |
| x.11      | T2 digital I/O 1 invert                 | OFF (0) or On (1)   |            | OFF (0)                 |    | RW   | Bit |    |    |    | US |
| x.12      | T3 digital I/O 2 invert                 | OFF (0) or On (1)   |            | OFF (0)                 |    | RW   | Bit |    |    |    | US |
| x.13      | T4 digital I/O 3 invert                 | OFF (0) or On (1)   |            | OFF (0)                 |    | RW   | Bit |    |    |    | US |
| x.14      | T6 digital input 4 invert               | OFF (0) or On (1)   |            | OFF (0)                 |    | RW   | Bit |    |    |    | US |
| x.15      | T7 digital input 5 invert               | OFF (0) or On (1)   |            | OFF (0)                 |    | RW   | Bit |    |    |    | US |
| x.16      | T8 digital input 6 invert               | OFF (0) or On (1)   |            | OFF (0)                 |    | RW   | Bit |    |    |    | US |
| x.17      | Relay 1 invert                          | OFF (0) or On (1)   |            | OFF (0)                 |    | RW   | Bit |    |    |    | US |
| x.18      | Relay 2 invert                          | OFF (0) or On (1)   |            | OFF (0)                 |    | RW   | Bit |    |    |    | US |
| x.20      | Digital I/O read word                   | 0 to 511            |            |                         |    | RO   | Uni |    | NC | PT |    |
| x.21      | T2 digital I/O 1 source/<br>destination | Pr 0.00 to Pr 21.51 |            | Pr 0.00                 |    | RW   | Uni | DE |    | PT | US |
| x.22      | T3 digital I/O 2 source/<br>destination | Pr 0.00 to Pr 21.51 |            | Pr 0.00                 |    | RW   | Uni | DE |    | PT | US |
| x.23      | T4 digital I/O 3 source/<br>destination | Pr 0.00 to Pr 21.51 |            | Pr 0.00                 |    | RW   | Uni | DE |    | PT | US |
| x.24      | T6 digital input 4 destination          | Pr 0.00 to Pr 21.51 |            | Pr 0.00                 |    | RW   | Uni | DE |    | PT | US |
| x.25      | T7 digital input 5 destination          | Pr 0.00 to Pr 21.51 |            | Pr 0.00                 |    | RW   | Uni | DE |    | PT | US |
| x.26      | T8 digital input 6 destination          | Pr 0.00 to Pr 21.51 |            | Pr 0.00                 |    | RW   | Uni | DE |    | PT | US |
| x.27      | Relay 1 source                          | Pr 0.00 to Pr 21.51 |            | Pr 0.00                 |    | RW   | Uni |    |    | PT | US |
| x.28      | Relay 2 source                          | Pr 0.00 to Pr 21.51 |            | Pr 0.00                 |    | RW   | Uni |    |    | PT | US |
| x.29      | Input polarity select                   | OFF (0) or On (1)   |            | On (1) (positive logic) |    | RW   | Bit |    |    | PT | US |
| x.31      | T2 digital I/O 1 output select          | OFF (0) or On (1)   |            | OFF (0)                 |    | RW   | Bit |    |    |    | US |
| x.32      | T3 digital I/O 2 output select          | OFF (0) or On (1)   |            | OFF (0)                 |    | RW   | Bit |    |    |    | US |
| x.33      | T4 digital I/O 3 output select          | OFF (0) or On (1)   |            | OFF (0)                 |    | RW   | Bit |    |    |    | US |
| x.40      | Analogue input 1                        | ±100.0%             |            |                         |    | RO   | Bi  |    | NC | PT |    |
| x.41      | Analogue input 1 scaling                | 0 to 4.000          |            | 1.000                   |    | RW   | Uni |    |    |    | US |
| x.42      | Analogue input 1 invert                 | OFF (0) or On (1)   |            | OFF (0)                 |    | RW   | Bit |    |    |    | US |
| x.43      | Analogue input 1 destination            | Pr 0.00 to Pr 21.51 |            | Pr 0.00                 |    | RW   | Uni | DE |    | PT | US |
| x.44      | Analogue input 2                        | ±100.0%             |            |                         |    | RO   | Bi  |    | NC | PT |    |
| x.45      | Analogue input 2 scaling                | 0.000 to 4.000      |            | 1.000                   |    | RW   | Uni |    |    |    | US |
| x.46      | Analogue input 2 invert                 | OFF (0) or On (1)   |            | OFF (0)                 |    | RW   | Bit |    |    |    | US |
| x.47      | Analogue input 2 destination            | Pr 0.00 to Pr 21.51 |            | Pr 0.00                 |    | RW   | Uni | DE |    | PT | US |
| x.48      | Analogue output 1 source                | Pr 0.00 to Pr 21.51 |            | Pr 0.00                 |    | RW   | Uni |    |    | PT | US |
| x.49      | Analogue output 1 scaling               | 0.000 to 4.000      |            | 1.000                   |    | RW   | Uni |    |    |    | US |
| x.50      | Solutions Module error status*          | 0 to 255            |            |                         |    | RO   | Uni |    | NC | PT |    |

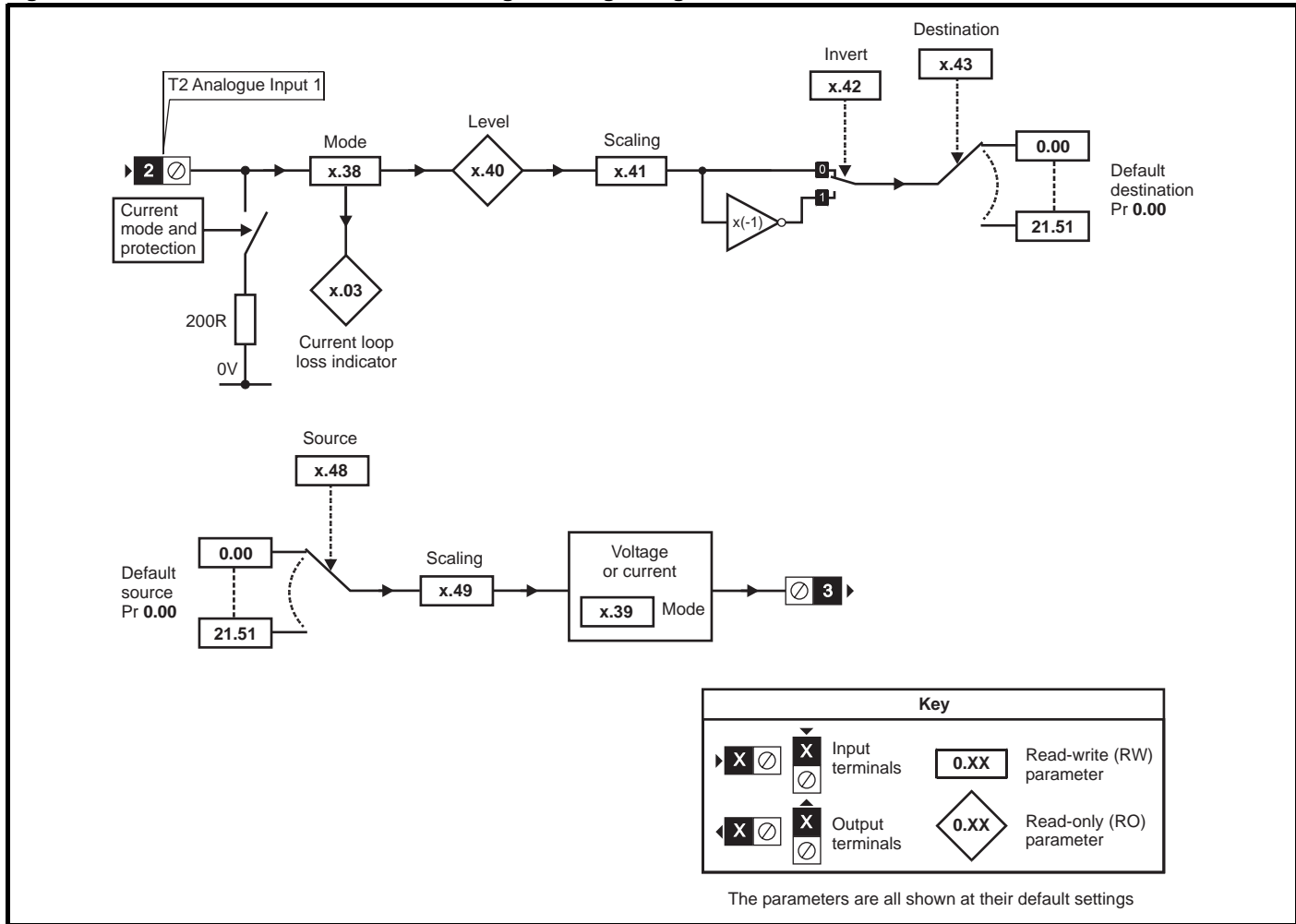
|    |              |    |             |     |            |    |                  |     |               |     |             |    |                 |
|----|--------------|----|-------------|-----|------------|----|------------------|-----|---------------|-----|-------------|----|-----------------|
| RW | Read / Write | RO | Read only   | Uni | Unipolar   | Bi | Bi-polar         | Bit | Bit parameter | Txt | Text string |    |                 |
| Fl | Filtered     | DE | Destination | NC  | Not cloned | RA | Rating dependent | PT  | Protected     | US  | User save   | PS | Power down save |

\*See trip SLX.Er, *Automation (I/O Expansion) module category* on page 286.

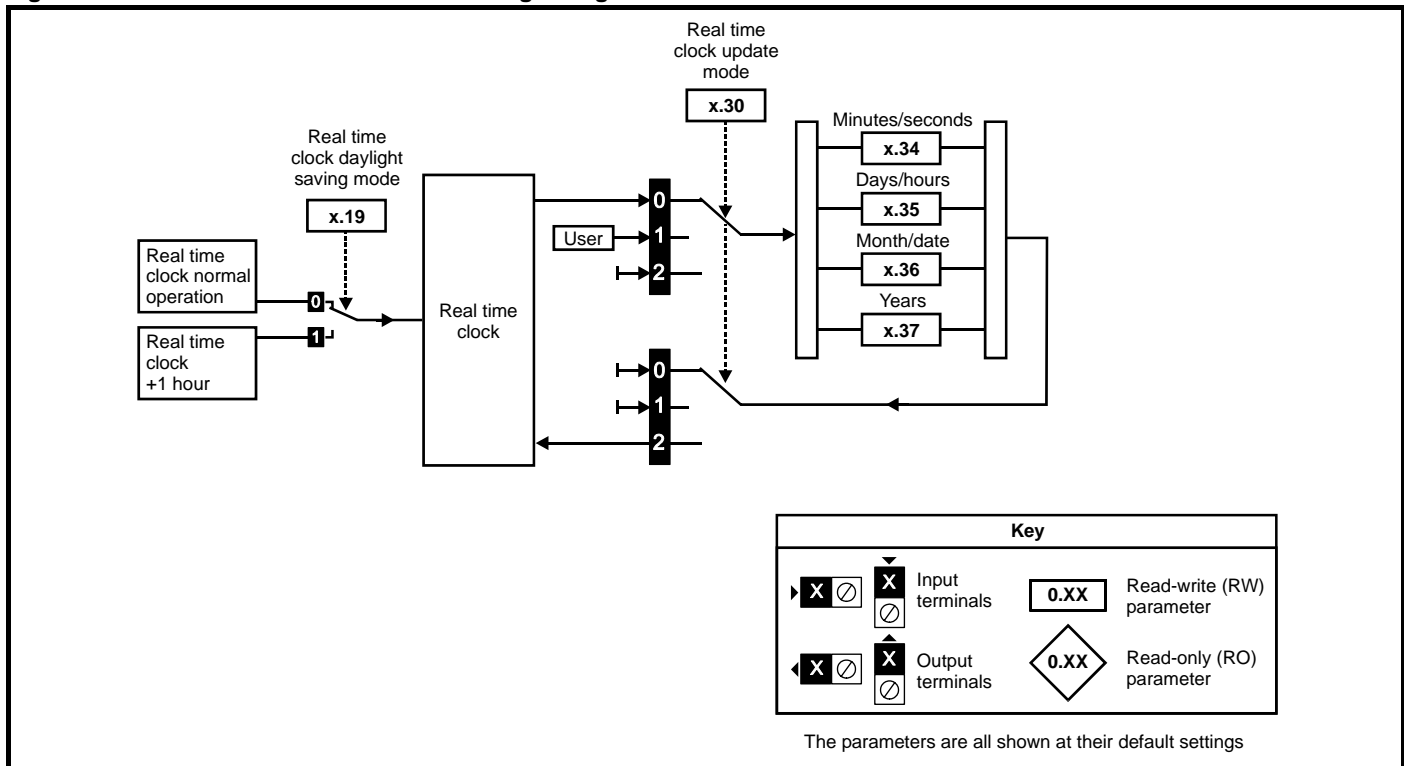
**Figure 11-30 SM-I/O Lite & SM-I/O Timer digital I/O logic diagram**



**Figure 11-31 SM-I/O Lite & SM-I/O Timer analogue I/O logic diagram**



**Figure 11-32 SM-I/O Timer real time clock logic diagram**



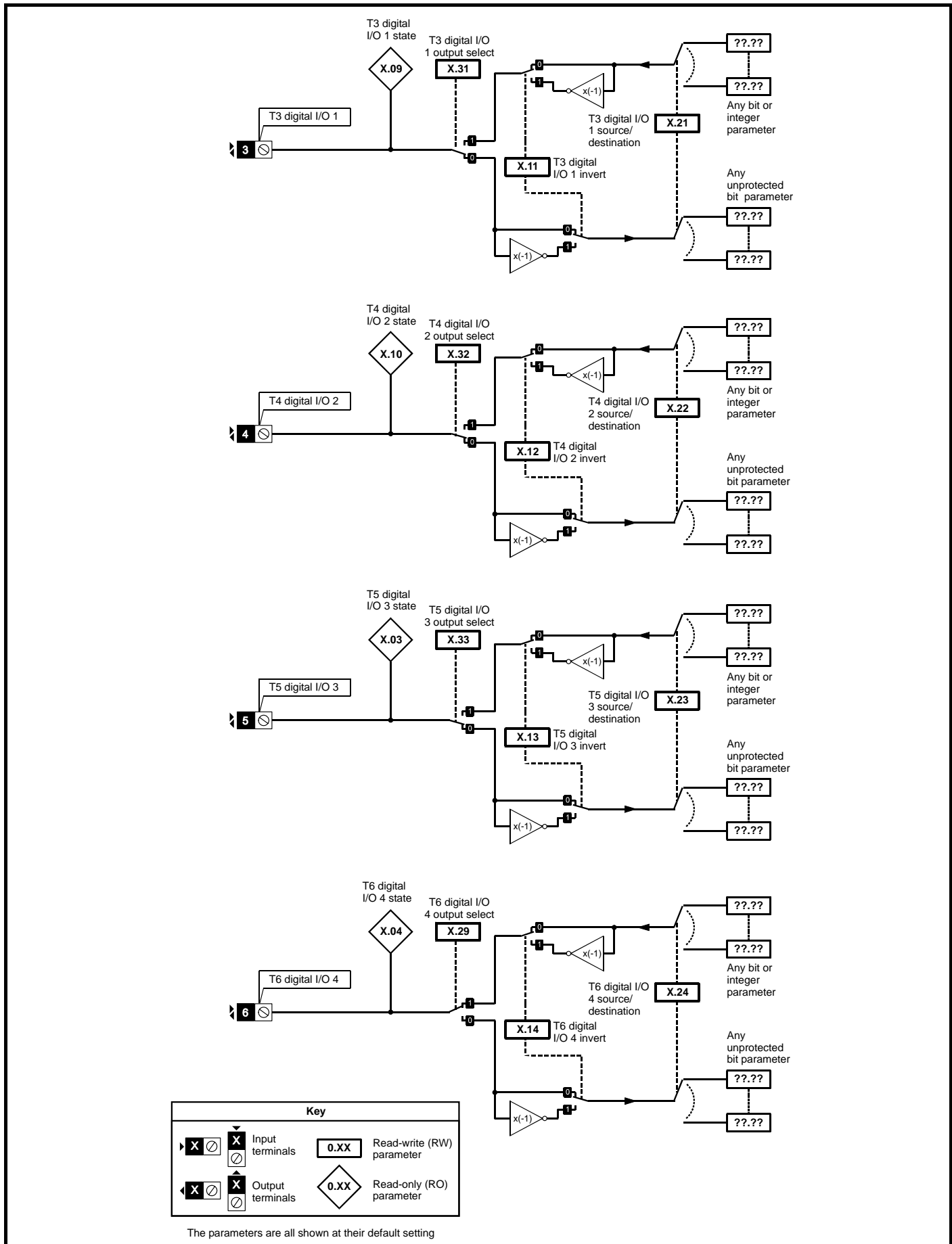
### SM-I/O Timer & SM-I/O Lite parameters

| Parameter |                                       | Range(⇅)  |    | Default(⇔)                            |    |    | Type |     |    |    |    | SM-I/O |       |   |
|-----------|---------------------------------------|---|----|---------------------------------------|----|----|------|-----|----|----|----|--------|-------|---|
|           |                                       | OL  | CL | OL                                    | VT | SV |      |     |    |    |    | Lite   | Timer |   |
| x.01      | Solutions Module ID                   | 0 to 599  |    | SM-I/O Timer: 203<br>SM0I/O Lite: 207 |    |    | RO   | Uni |    |    | PT | US     | ✓     | ✓ |
| x.02      | Solutions Module software version     | 0.00 to 99.99   |    |                                       |    |    | RO   | Uni |    | NC | PT |        | ✓     | ✓ |
| x.03      | Current loop loss indicator           | OFF (0) or On (1)   |    |                                       |    |    | RO   | Bit |    | NC | PT |        | ✓     | ✓ |
| x.04      | T5 digital input 4 state              | OFF (0) or On (1)   |    |                                       |    |    | RO   | Bit |    | NC | PT |        | ✓     | ✓ |
| x.05      | T6 digital input 5 state              | OFF (0) or On (1)   |    |                                       |    |    | RO   | Bit |    | NC | PT |        | ✓     | ✓ |
| x.06      | T7 digital input 6 state              | OFF (0) or On (1)   |    |                                       |    |    | RO   | Bit |    | NC | PT |        | ✓     | ✓ |
| x.07      | Relay 1 state                         | OFF (0) or On (1)   |    |                                       |    |    | RO   | Bit |    | NC | PT |        | ✓     | ✓ |
| x.14      | T5 digital input 4 invert             | OFF (0) or On (1)   |    | OFF (0)                               |    |    | RW   | Bit |    |    |    | US     | ✓     | ✓ |
| x.15      | T6 digital input 5 invert             | OFF (0) or On (1)   |    | OFF (0)                               |    |    | RW   | Bit |    |    |    | US     | ✓     | ✓ |
| x.16      | T7 digital input 6 invert             | OFF (0) or On (1)   |    | OFF (0)                               |    |    | RW   | Bit |    |    |    | US     | ✓     | ✓ |
| x.17      | Relay 1 invert                        | OFF (0) or On (1)   |    | OFF (0)                               |    |    | RW   | Bit |    |    |    | US     | ✓     | ✓ |
| x.19      | Real time clock daylight saving mode  | OFF (0) or On (1)   |    | OFF (0)                               |    |    | RW   | Bit |    |    |    | US     | ✓     | ✓ |
| x.20      | Digital I/O read word                 | 0 to 255  |    |                                       |    |    | RO   | Uni |    | NC | PT |        | ✓     | ✓ |
| x.24      | T5 digital input 4 destination        | Pr 0.00 to Pr 21.51   |    | Pr 0.00                               |    |    | RW   | Uni | DE |    | PT | US     | ✓     | ✓ |
| x.25      | T6 digital input 5 destination        | Pr 0.00 to Pr 21.51   |    | Pr 0.00                               |    |    | RW   | Uni | DE |    | PT | US     | ✓     | ✓ |
| x.26      | T7 digital input 6 destination        | Pr 0.00 to Pr 21.51   |    | Pr 0.00                               |    |    | RW   | Uni | DE |    | PT | US     | ✓     | ✓ |
| x.27      | Relay 1 source                        | Pr 0.00 to Pr 21.51   |    | Pr 0.00                               |    |    | RW   | Uni |    |    | PT | US     | ✓     | ✓ |
| x.30      | Real time clock update mode           | 0 to 2  |    | 0                                     |    |    | RW   | Uni |    | NC |    |        |       | ✓ |
| x.34      | Real time clock time: minutes.seconds | 0.00 to 59.59   |    |                                       |    |    | RW   | Uni |    | NC | PT |        |       | ✓ |
| x.35      | Real time clock time: days.hours      | 1.00 to 7.23  |    |                                       |    |    | RW   | Uni |    | NC | PT |        |       | ✓ |
| x.36      | Real time clock time: months.days     | 0.00 to 12.31   |    |                                       |    |    | RW   | Uni |    | NC | PT |        |       | ✓ |
| x.37      | Real time clock time: years           | 2000 to 2099  |    |                                       |    |    | RW   | Uni |    | NC | PT |        |       | ✓ |
| x.38      | Analogue input 1 mode                 | 0-20 (0), 20-0 (1), 4-20.tr (2), 20-4.tr (3), 4-20 (4), 20-4 (5), VOLT(6) |    | 0-20 (0)                              |    |    | RW   | Txt |    |    |    | US     | ✓     | ✓ |
| x.39      | Analogue output mode                  | 0-20 (0), 20-0 (1), 4-20 (2), 20-4 (3), VOLT (4)                          |    | 0-20 (0)                              |    |    | RW   | Txt |    |    |    | US     | ✓     | ✓ |
| x.40      | Analogue input 1                      | ±100.0%   |    |                                       |    |    | RO   | Bi  |    | NC | PT |        | ✓     | ✓ |
| x.41      | Analogue input 1 scaling              | 0 to 4.000  |    | 1.000                                 |    |    | RW   | Uni |    |    |    | US     | ✓     | ✓ |
| x.42      | Analogue input 1 invert               | OFF (0) or On (1)   |    | OFF (0)                               |    |    | RW   | Bit |    |    |    | US     | ✓     | ✓ |
| x.43      | Analogue input 1 destination          | Pr 0.00 to Pr 21.51   |    | Pr 0.00                               |    |    | RW   | Uni | DE |    | PT | US     | ✓     | ✓ |
| x.48      | Analogue output 1 source              | Pr 0.00 to Pr 21.51   |    | Pr 0.00                               |    |    | RW   | Uni |    |    | PT | US     | ✓     | ✓ |
| x.49      | Analogue output 1 scaling             | 0.000 to 4.000  |    | 1.000                                 |    |    | RW   | Uni |    |    |    | US     | ✓     | ✓ |
| x.50      | Solutions Module error status*        | 0 to 255  |    |                                       |    |    | RO   | Uni |    | NC | PT |        | ✓     | ✓ |
| x.51      | Solutions Module software sub-version | 0 to 99   |    |                                       |    |    | RO   | Uni |    | NC | PT |        | ✓     | ✓ |

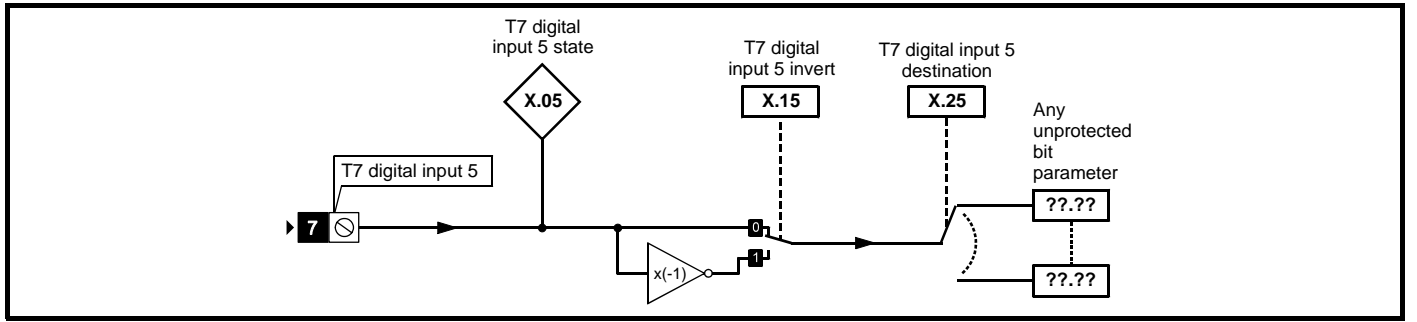
|    |              |    |             |     |            |    |                  |     |               |     |             |    |                 |
|----|--------------|----|-------------|-----|------------|----|------------------|-----|---------------|-----|-------------|----|-----------------|
| RW | Read / Write | RO | Read only   | Uni | Unipolar   | Bi | Bi-polar         | Bit | Bit parameter | Txt | Text string |    |                 |
| FI | Filtered     | DE | Destination | NC  | Not cloned | RA | Rating dependent | PT  | Protected     | US  | User save   | PS | Power down save |

\*See trip SLX.Er, Automation (I/O Expansion) module category on page 286.

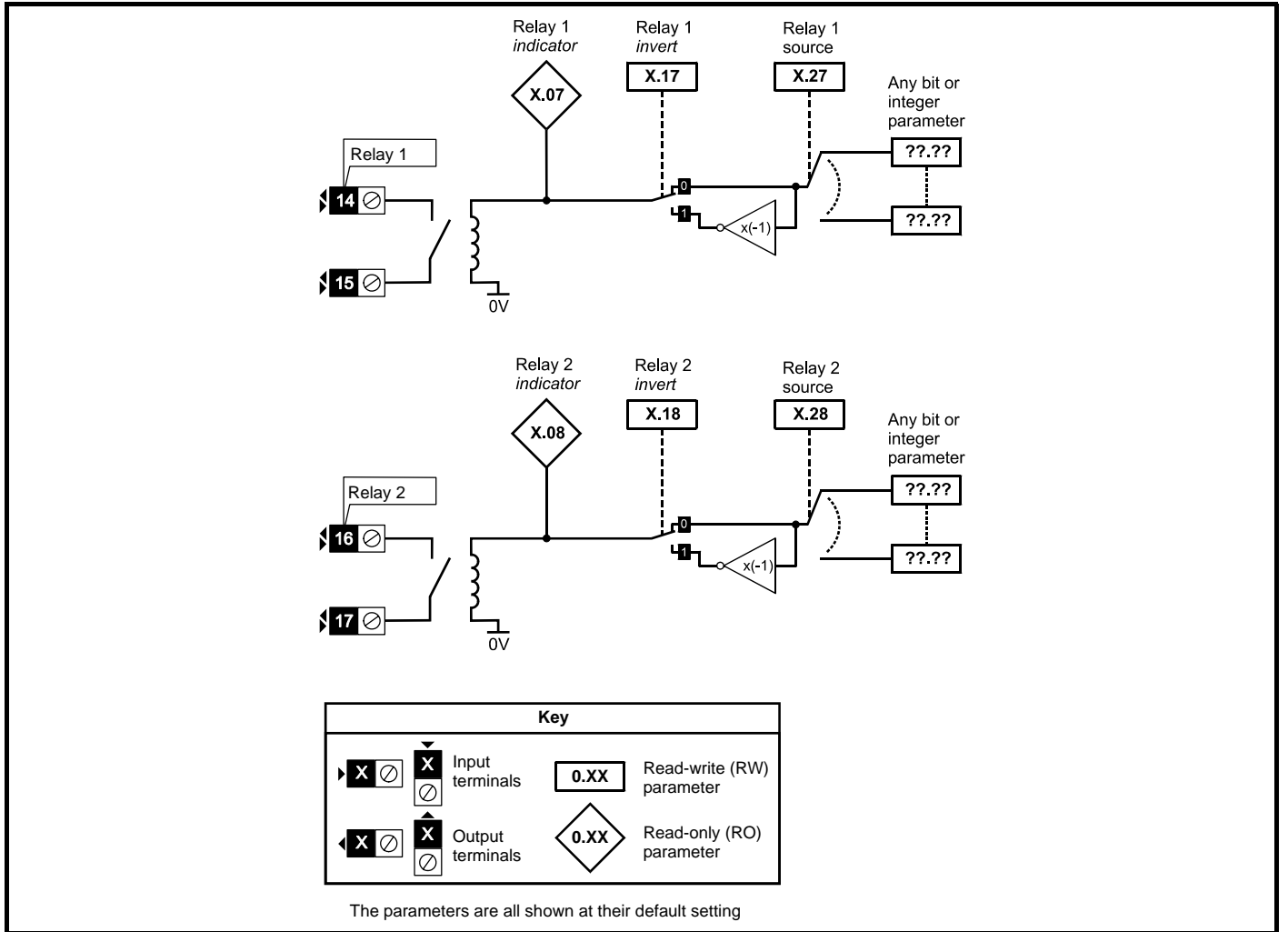
**Figure 11-33 SM-PELV digital I/O logic diagram**



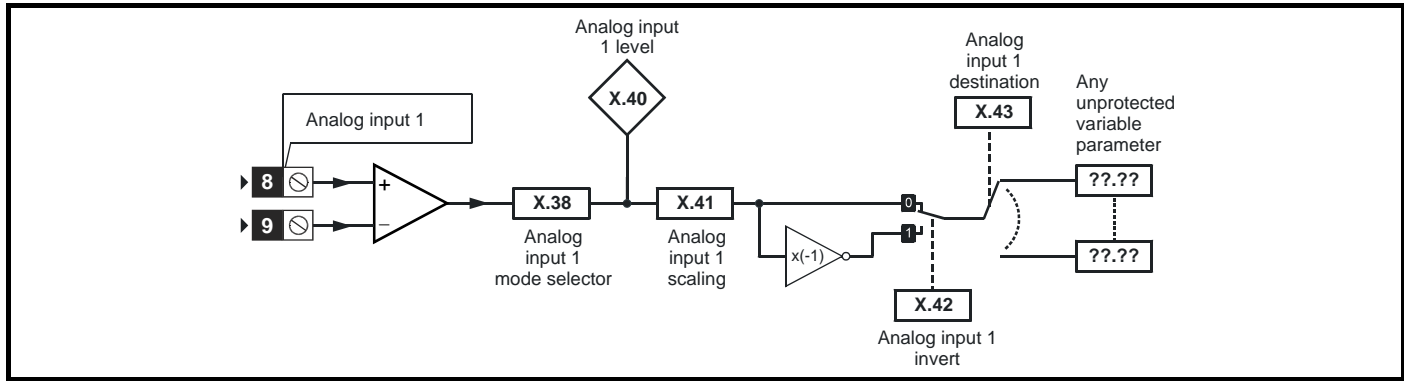
**Figure 11-34 SM-PELV digital input logic diagram**



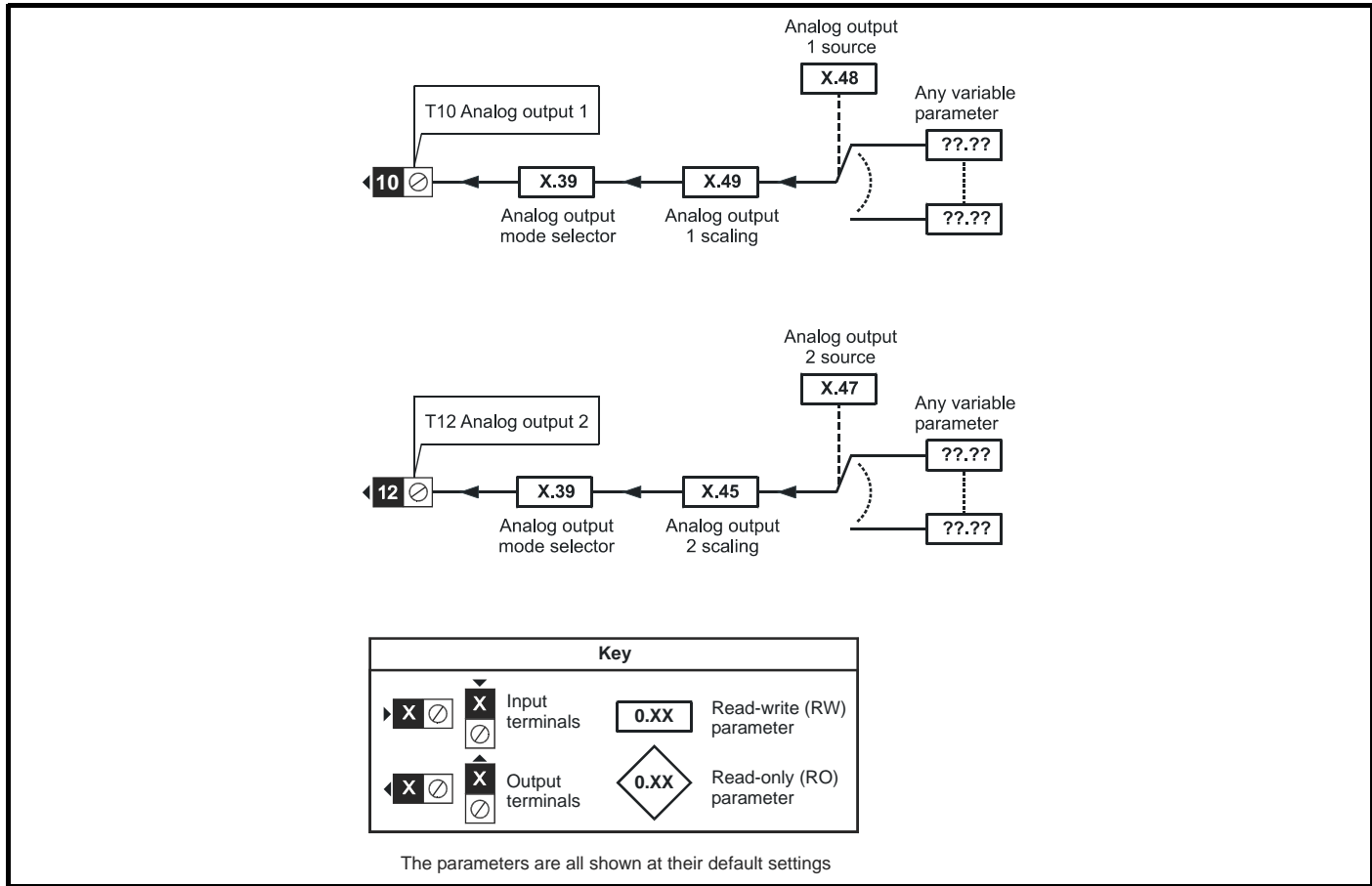
**Figure 11-35 SM-PELV relay logic diagram**



**Figure 11-36 SM-PELV analog input logic diagram**



**Figure 11-37 SM-PELV analog output logic diagram**



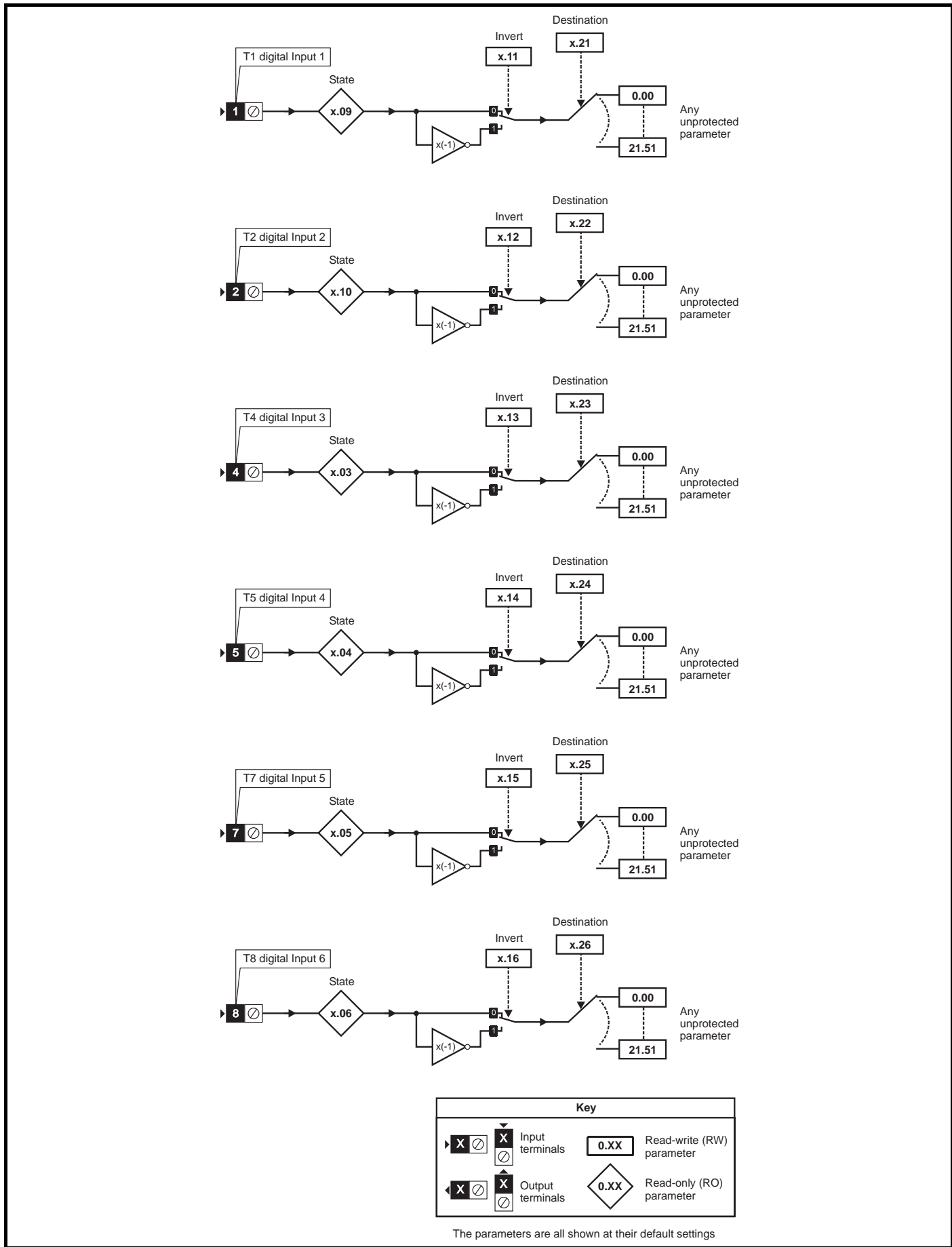
### SM-PELV parameters

| Parameter                                  | Range(⇅)   |    | Default(⇔) |    |    | Type |     |    |    |    |    |
|--|--|----|------------|----|----|------|-----|----|----|----|----|
|  | OL   | CL | OL         | VT | SV |      |     |    |    |    |    |
| x.01 Solutions Module ID                   | 0 to 599   |    | 204        |    |    | RO   | Uni |    |    | PT | US |
| x.02 Solutions Module software version     | 0.00 to 99.99  |    |            |    |    | RO   | Uni |    | NC | PT |    |
| x.03 T5 digital I/O 3 state                | OFF (0) or On (1)  |    |            |    |    | RO   | Bit |    | NC | PT |    |
| x.04 T6 digital I/O 4 state                | OFF (0) or On (1)  |    |            |    |    | RO   | Bit |    | NC | PT |    |
| x.05 T7 digital input 5 state              | OFF (0) or On (1)  |    |            |    |    | RO   | Bit |    | NC | PT |    |
| x.07 Relay 1 state                         | OFF (0) or On (1)  |    |            |    |    | RO   | Bit |    | NC | PT |    |
| x.08 Relay 2 state                         | OFF (0) or On (1)  |    |            |    |    | RO   | Bit |    | NC | PT |    |
| x.09 T3 digital I/O 1 state                | OFF (0) or On (1)  |    |            |    |    | RO   | Bit |    | NC | PT |    |
| x.10 T4 digital I/O 2 state                | OFF (0) or On (1)  |    |            |    |    | RO   | Bit |    | NC | PT |    |
| x.11 T3 digital I/O 1 invert               | OFF (0) or On (1)  |    | OFF (0)    |    |    | RW   | Bit |    |    |    | US |
| x.12 T4 digital I/O 2 invert               | OFF (0) or On (1)  |    | OFF (0)    |    |    | RW   | Bit |    |    |    | US |
| x.13 T5 digital I/O 3 invert               | OFF (0) or On (1)  |    | OFF (0)    |    |    | RW   | Bit |    |    |    | US |
| x.14 T6 digital I/O 4 invert               | OFF (0) or On (1)  |    | OFF (0)    |    |    | RW   | Bit |    |    |    | US |
| x.15 T7 digital input 5 invert             | OFF (0) or On (1)  |    | OFF (0)    |    |    | RW   | Bit |    |    |    | US |
| x.17 Relay 1 invert                        | OFF (0) or On (1)  |    | OFF (0)    |    |    | RW   | Bit |    |    |    | US |
| x.18 Relay 2 invert                        | OFF (0) or On (1)  |    | OFF (0)    |    |    | RW   | Bit |    |    |    | US |
| x.20 Digital I/O read word                 | 0 to 255   |    |            |    |    | RO   | Uni |    | NC | PT |    |
| x.21 T3 digital I/O 1 source/destination   | Pr 0.00 to Pr 21.51  |    | Pr 0.00    |    |    | RW   | Uni | DE |    | PT | US |
| x.22 T4 digital I/O 2 source/destination   | Pr 0.00 to Pr 21.51  |    | Pr 0.00    |    |    | RW   | Uni | DE |    | PT | US |
| x.23 T5 digital I/O 3 source/destination   | Pr 0.00 to Pr 21.51  |    | Pr 0.00    |    |    | RW   | Uni | DE |    | PT | US |
| x.24 T6 digital I/O 4 source/destination   | Pr 0.00 to Pr 21.51  |    | Pr 0.00    |    |    | RW   | Uni | DE |    | PT | US |
| x.25 T7 digital input 5 destination        | Pr 0.00 to Pr 21.51  |    | Pr 0.00    |    |    | RW   | Uni | DE |    | PT | US |
| x.27 Relay 1 source                        | Pr 0.00 to Pr 21.51  |    | Pr 0.00    |    |    | RW   | Uni |    |    | PT | US |
| x.28 Relay 2 source                        | Pr 0.00 to Pr 21.51  |    | Pr 0.00    |    |    | RW   | Uni |    |    | PT | US |
| x.29 T6 digital I/O 4 output select        | OFF (0) or On (1)  |    | On (1)     |    |    | RW   | Bit |    |    |    | US |
| x.31 T3 digital I/O 1 output select        | OFF (0) or On (1)  |    | OFF (0)    |    |    | RW   | Bit |    |    |    | US |
| x.32 T4 digital I/O 2 output select        | OFF (0) or On (1)  |    | OFF (0)    |    |    | RW   | Bit |    |    |    | US |
| x.33 T5 digital I/O 3 output select        | OFF (0) or On (1)  |    | OFF (0)    |    |    | RW   | Bit |    |    |    | US |
| x.38 Analogue input 1 mode                 | 0-20 (0), 20-0 (1), 4-20.tr (2), 20-4.tr (3), 4-20 (4), 20-4 (5) |    | 0-20 (0)   |    |    | RW   | Txt |    |    |    | US |
| x.39 Analogue output mode                  | 0-20 (0), 20-0 (1), 4-20 (2), 20-4 (3)                           |    | 0-20 (0)   |    |    | RW   | Txt |    |    |    | US |
| x.40 Analogue input 1 level                | 0.0 to 100.0%  |    |            |    |    | RO   | Bi  |    | NC | PT |    |
| x.41 Analogue input 1 scaling              | 0.000 to 4.000   |    | 1.000      |    |    | RW   | Uni |    |    |    | US |
| x.42 Analogue input 1 invert               | OFF (0) or On (1)  |    | OFF (0)    |    |    | RW   | Bit |    |    |    | US |
| x.43 Analogue input 1 destination          | Pr 0.00 to Pr 21.51  |    | Pr 0.00    |    |    | RW   | Uni | DE |    | PT | US |
| x.45 Analogue output 2 scaling             | 0.000 to 4.000   |    | 1.000      |    |    | RW   | Uni |    |    |    | US |
| x.47 Analogue output 2 source              | Pr 0.00 to Pr 21.51  |    | Pr 0.00    |    |    | RW   | Uni |    |    | PT | US |
| x.48 Analogue output 1 source              | Pr 0.00 to Pr 21.51  |    | Pr 0.00    |    |    | RW   | Uni |    |    | PT | US |
| x.49 Analogue output 1 scaling             | 0.000 to 4.000   |    | 1.000      |    |    | RW   | Uni |    |    |    | US |
| x.50 Solutions Module error status*        | 0 to 255   |    |            |    |    | RO   | Uni |    | NC | PT |    |
| x.51 Solutions Module software sub-version | 0 to 99  |    |            |    |    | RO   | Uni |    | NC | PT |    |

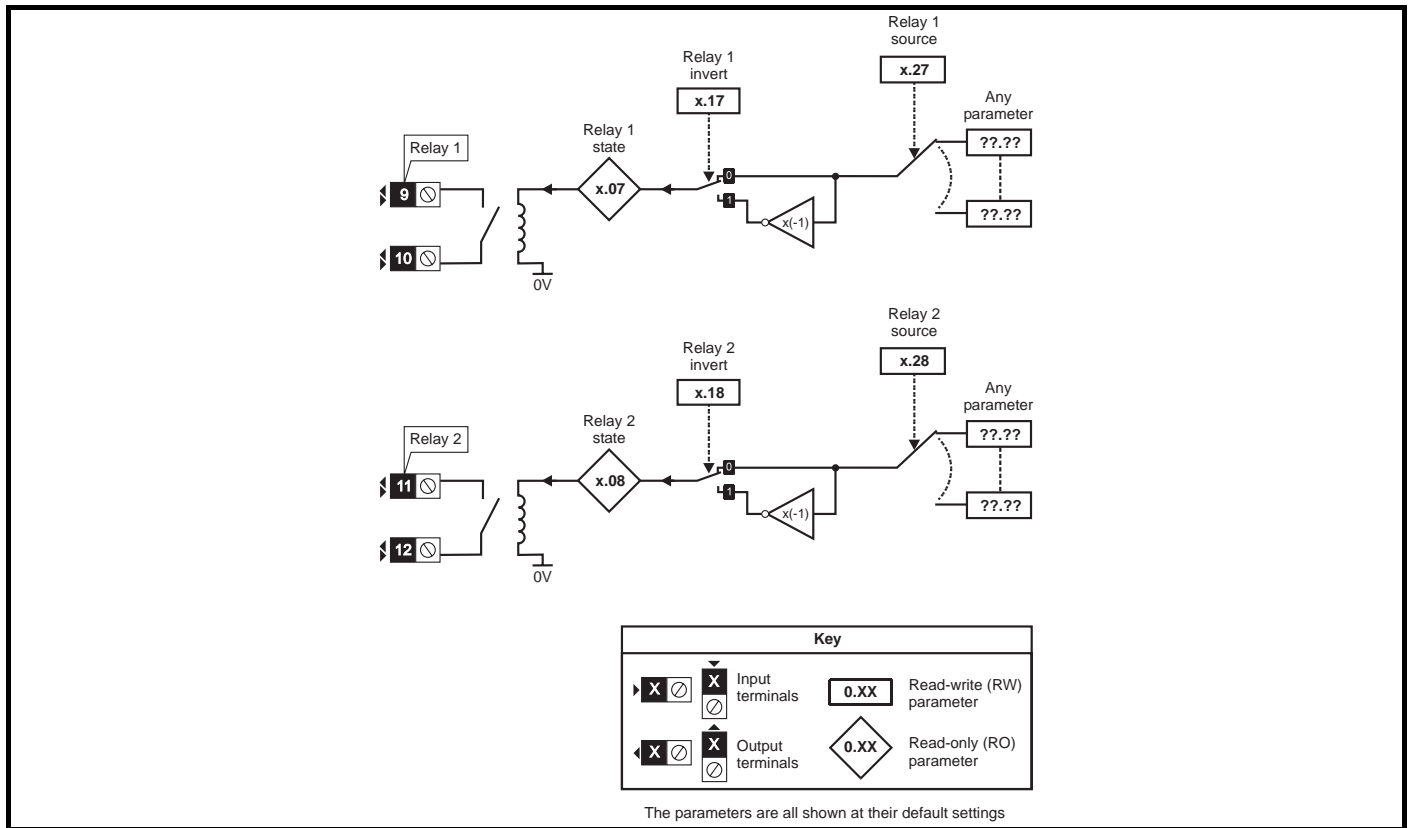
|    |              |    |             |     |            |    |                  |     |               |     |             |    |                 |
|----|--------------|----|-------------|-----|------------|----|------------------|-----|---------------|-----|-------------|----|-----------------|
| RW | Read / Write | RO | Read only   | Uni | Unipolar   | Bi | Bi-polar         | Bit | Bit parameter | Txt | Text string |    |                 |
| Fl | Filtered     | DE | Destination | NC  | Not cloned | RA | Rating dependent | PT  | Protected     | US  | User save   | PS | Power down save |

\*See trip SLX.Er, *Automation (I/O Expansion) module category* on page 286.

**Figure 11-38 SM-I/O 120V digital input logic diagram**



**Figure 11-39 SM-I/O 120V digital I/O logic diagram**



**SM-I/O 120V parameters**

| Parameter | Range(⇅)                              |                     | Default(⇒) |         |    | Type |     |    |    |    |
|-----------|---------------------------------------|---------------------|------------|---------|----|------|-----|----|----|----|
|           | OL                                    | CL                  | OL         | VT      | SV | RO   | Uni | DE | PT | US |
| x.01      | Solutions Module ID                   | 0 to 599            |            | 206     |    | RO   | Uni |    | PT | US |
| x.02      | Solutions Module software version     | 0.00 to 99.99       |            |         |    | RO   | Uni | NC | PT |    |
| x.03      | T4 digital input 3 state              | OFF (0) or On (1)   |            |         |    | RO   | Bit | NC | PT |    |
| x.04      | T5 digital input 4 state              | OFF (0) or On (1)   |            |         |    | RO   | Bit | NC | PT |    |
| x.05      | T7 digital input 5 state              | OFF (0) or On (1)   |            |         |    | RO   | Bit | NC | PT |    |
| x.06      | T8 digital input 6 state              | OFF (0) or On (1)   |            |         |    | RO   | Bit | NC | PT |    |
| x.07      | Relay 1 state                         | OFF (0) or On (1)   |            |         |    | RO   | Bit | NC | PT |    |
| x.08      | Relay 2 state                         | OFF (0) or On (1)   |            |         |    | RO   | Bit | NC | PT |    |
| x.09      | T1 digital input 1 state              | OFF (0) or On (1)   |            |         |    | RO   | Bit | NC | PT |    |
| x.10      | T2 digital input 2 state              | OFF (0) or On (1)   |            |         |    | RO   | Bit | NC | PT |    |
| x.11      | T1 digital input 1 invert             | OFF (0) or On (1)   |            | OFF (0) |    | RW   | Bit |    |    | US |
| x.12      | T2 digital input 2 invert             | OFF (0) or On (1)   |            | OFF (0) |    | RW   | Bit |    |    | US |
| x.13      | T4 digital input 3 invert             | OFF (0) or On (1)   |            | OFF (0) |    | RW   | Bit |    |    | US |
| x.14      | T5 digital input 4 invert             | OFF (0) or On (1)   |            | OFF (0) |    | RW   | Bit |    |    | US |
| x.15      | T7 digital input 5 invert             | OFF (0) or On (1)   |            | OFF (0) |    | RW   | Bit |    |    | US |
| x.16      | T8 digital input 6 invert             | OFF (0) or On (1)   |            | OFF (0) |    | RW   | Bit |    |    | US |
| x.17      | Relay 1 invert                        | OFF (0) or On (1)   |            | OFF (0) |    | RW   | Bit |    |    | US |
| x.18      | Relay 2 invert                        | OFF (0) or On (1)   |            | OFF (0) |    | RW   | Bit |    |    | US |
| x.20      | Digital I/O read word                 | 0 to 255            |            |         |    | RO   | Uni |    | NC | PT |
| x.21      | T1 digital input 1 destination        | Pr 0.00 to Pr 21.51 |            | Pr 0.00 |    | RW   | Uni | DE |    | PT |
| x.22      | T2 digital input 2 destination        | Pr 0.00 to Pr 21.51 |            | Pr 0.00 |    | RW   | Uni | DE |    | PT |
| x.23      | T4 digital input 3 destination        | Pr 0.00 to Pr 21.51 |            | Pr 0.00 |    | RW   | Uni | DE |    | PT |
| x.24      | T5 digital input 4 destination        | Pr 0.00 to Pr 21.51 |            | Pr 0.00 |    | RW   | Uni | DE |    | PT |
| x.25      | T7 digital input 5 destination        | Pr 0.00 to Pr 21.51 |            | Pr 0.00 |    | RW   | Uni | DE |    | PT |
| x.26      | T8 digital input 6 destination        | Pr 0.00 to Pr 21.51 |            | Pr 0.00 |    | RW   | Uni | DE |    | PT |
| x.27      | Relay 1 source                        | Pr 0.00 to Pr 21.51 |            | Pr 0.00 |    | RW   | Uni |    |    | PT |
| x.28      | Relay 2 source                        | Pr 0.00 to Pr 21.51 |            | Pr 0.00 |    | RW   | Uni |    |    | PT |
| x.50      | Solutions Module error status*        | 0 to 255            |            |         |    | RO   | Uni |    | NC | PT |
| x.51      | Solutions Module software sub-version | 0 to 99             |            |         |    | RO   | Uni |    | NC | PT |

|    |              |    |             |     |            |    |                  |     |               |     |             |    |                 |
|----|--------------|----|-------------|-----|------------|----|------------------|-----|---------------|-----|-------------|----|-----------------|
| RW | Read / Write | RO | Read only   | Uni | Unipolar   | Bi | Bi-polar         | Bit | Bit parameter | Txt | Text string |    |                 |
| FI | Filtered     | DE | Destination | NC  | Not cloned | RA | Rating dependent | PT  | Protected     | US  | User save   | PS | Power down save |

\*See trip SLX.Er, Automation (I/O Expansion) module category on page 286.

### Applications module parameters

| Parameter   | Range(⇅)   |    | Default(⇄) |    |               | Type |     |  |    |    |    |
|---|--|----|------------|----|---------------|------|-----|--|----|----|----|
|   | OL   | CL | OL         | VT | SV            | RO   | Uni |  |    | PT | US |
| x.01 Solutions Module ID  | 0 to 599   |    |            |    |               | RO   | Uni |  |    | PT | US |
| x.02 Solutions Module software version                              | 0.00 to 99.99  |    |            |    |               | RO   | Uni |  | NC | PT |    |
| x.03 DPL program status   | None (0), Stop (1), Run (2), Trip (3)  |    |            |    |               | RO   | Txt |  | NC | PT |    |
| x.04 Available system resource                                      | 0 to 100   |    |            |    |               | RO   | Uni |  | NC | PT |    |
| x.05 RS485 address  | 0 to 255   |    |            |    | 11            | RW   | Uni |  |    |    | US |
| x.06 RS485 mode   | 0 to 255   |    |            |    | 1             | RW   | Uni |  |    |    | US |
| x.07 RS485 baud rate  | 300 (0), 600 (1), 1200 (2), 2400 (3), 4800 (4), 9600 (5), 19200 (6), 38400 (7), 57600 (8), 115200 (9) baud |    |            |    | 4800 (4)      | RW   | Txt |  |    |    | US |
| x.08 RS485 Turnaround delay   | 0 to 255 ms  |    |            |    | 2             | RW   | Uni |  |    |    | US |
| x.09 RS485 Tx enable delay  | 0 to 1 ms  |    |            |    | 0             | RW   | Uni |  |    |    | US |
| x.10 DPL Print Routing  | SYPT: OFF (0), RS485: On (1)   |    |            |    | SYPT: OFF (0) | RW   | Bit |  |    |    | US |
| x.11 Clock tick time (ms)   | 0 to 200   |    |            |    | 10            | RW   | Uni |  |    |    | US |
| x.12 Motion engine sample rate                                      | dISAbLEd (0), 0.25 ms (1), 0.5 ms (2), 1 ms (3), 2 ms (4), 4 ms (5), 8 ms (6)                              |    |            |    | dISAbLEd (0)  | RW   | Txt |  |    |    | US |
| x.13 Enable autorun   | OFF (0) or On (1)  |    |            |    | On (1)        | RW   | Bit |  |    |    | US |
| x.14 Global run time trip enable                                    | OFF (0) or On (1)  |    |            |    | OFF (0)       | RW   | Bit |  |    |    | US |
| x.15 Disable reset on trip cleared                                  | OFF (0) or On (1)  |    |            |    | OFF (0)       | RW   | Bit |  |    |    | US |
| x.16 Encoder data update rate                                       | 0 to 3   |    |            |    | 0             | RW   | Uni |  |    |    | US |
| x.17 Enable parameter over range trips                              | OFF (0) or On (1)  |    |            |    | OFF (0)       | RW   | Bit |  |    |    | US |
| x.18 Watchdog enable  | OFF (0) or On (1)  |    |            |    | OFF (0)       | RW   | Bit |  |    |    | US |
| x.19 Save request   | OFF (0) or On (1)  |    |            |    | OFF (0)       | RW   | Bit |  | NC |    |    |
| x.20 Enable power down save   | OFF (0) or On (1)  |    |            |    | OFF (0)       | RW   | Bit |  |    |    | US |
| x.21 Enable menu 20 save and restore                                | OFF (0) or On (1)  |    |            |    | OFF (0)       | RW   | Bit |  |    |    | US |
| x.22 CTNet Token Ring ID  | 0 to 255   |    |            |    | 0             | RW   | Uni |  |    |    | US |
| x.23 CTNet node address   | 0 to 255   |    |            |    | 0             | RW   | Uni |  |    |    | US |
| x.24 CTNet baud rate  | 5.000 (0), 2.500 (1), 1.250 (2), 0.625 (3)   |    |            |    | 2.500 (1)     | RW   | Txt |  |    |    | US |
| x.25 CTNet sync setup   | 0,000 to 9,999   |    |            |    | 0,000         | RW   | Uni |  |    |    | US |
| x.26 CTNet easy mode - first cyclic parameter destination node      | 0 to 25,503  |    |            |    | 0             | RW   | Uni |  |    |    | US |
| x.27 CTNet easy mode - first cyclic source parameter                | 0 to 9,999   |    |            |    | 0             | RW   | Uni |  |    |    | US |
| x.28 CTNet easy mode - second cyclic parameter destination node     | 0 to 25,503  |    |            |    | 0             | RW   | Uni |  |    |    | US |
| x.29 CTNet easy mode - second cyclic source parameter               | 0 to 9,999   |    |            |    | 0             | RW   | Uni |  |    |    | US |
| x.30 CTNet easy mode - third cyclic parameter destination node      | 0 to 25,503  |    |            |    | 0             | RW   | Uni |  |    |    | US |
| x.31 CTNet easy mode - third cyclic source parameter                | 0 to 9,999   |    |            |    | 0             | RW   | Uni |  |    |    | US |
| x.32 CTNet easy mode set-up - Transfer slot 1 destination parameter | 0 to 9,999   |    |            |    | 0             | RW   | Uni |  |    |    | US |
| x.33 CTNet easy mode set-up - Transfer slot 2 destination parameter | 0 to 9,999   |    |            |    | 0             | RW   | Uni |  |    |    | US |
| x.34 CTNet easy mode set-up - Transfer slot 3 destination parameter | 0 to 9,999   |    |            |    | 0             | RW   | Uni |  |    |    | US |
| x.35 CTNet sync event task ID                                       | Disabled (0), Event (1), Event1 (2), Event2 (3), Event3 (4)  |    |            |    | Disabled (0)  | RW   | Txt |  |    |    | US |
| x.36 CTNet diagnostic parameter                                     |  |    |            |    |               | RO   | Uni |  | NC | PT |    |
| x.37 Reject download if drive enabled                               | OFF (0) or On (1)  |    |            |    | OFF (0)       | RW   | Bit |  |    |    | US |
| x.38 Do not trip drive on APC run-time error                        | OFF (0) or On (1)  |    |            |    | OFF (0)       | RW   | Bit |  |    |    | US |
| x.39 Inter-UT70 synchronisation status                              | 0 to 3   |    |            |    | 0             | RO   | Uni |  | NC |    |    |
| x.40 Inter-UT70 master transfer mode                                | 0 to 10  |    |            |    | 1             | RW   | Uni |  |    |    | US |
| x.42 Freeze main drive position                                     | OFF (0) or On (1)  |    |            |    | OFF (0)       | RW   | Bit |  |    |    | US |
| x.43 Freeze invert  | OFF (0) or On (1)  |    |            |    | OFF (0)       | RW   | Bit |  |    |    | US |
| x.44 Task priority level  | 0 to 255   |    |            |    | 0             | RW   | Uni |  |    |    | US |
| x.48 DPL line number in error                                       | 0 to 2,147,483,647   |    |            |    | 0             | RO   | Uni |  | NC | PT |    |
| x.49 User program ID  | -32,767 to +32,768   |    |            |    | 0             | RO   | Bi  |  | NC | PT |    |
| x.50 Solutions Module error status*                                 | 0 to 255   |    |            |    |               | RO   | Uni |  | NC | PT |    |
| x.51 Solutions Module software sub-version                          | 0 to 99  |    |            |    |               | RO   | Uni |  | NC | PT |    |

|    |              |    |             |     |            |    |                  |     |               |     |             |    |                 |
|----|--------------|----|-------------|-----|------------|----|------------------|-----|---------------|-----|-------------|----|-----------------|
| RW | Read / Write | RO | Read only   | Uni | Unipolar   | Bi | Bi-polar         | Bit | Bit parameter | Txt | Text string |    |                 |
| FI | Filtered     | DE | Destination | NC  | Not cloned | RA | Rating dependent | PT  | Protected     | US  | User save   | PS | Power down save |

\*See trip SLX.Er, *Automation (Applications) module category* on page 285.

## 11.15.4 Fieldbus module category

### Fieldbus module parameters

| Parameter    |   | Range( $\hat{\updownarrow}$ )   |    | Default( $\Rightarrow$ ) |    |         | Type |     |  |    |    |    |
|--------------|---|---------------------------------|----|--------------------------|----|---------|------|-----|--|----|----|----|
|              |   | OL                              | CL | OL                       | VT | SV      | RO   | Uni |  | NC | PT | US |
| x.01         | Solutions Module ID                     | 0 to 599                        |    |                          |    |         | RO   | Uni |  |    | PT | US |
| x.02         | Solutions Module software version       | 0.00 to 99.99                   |    |                          |    |         | RO   | Uni |  | NC | PT |    |
| x.03         | Fieldbus Node Address                   | 65,535                          |    |                          |    | 65,535  | RW   | Uni |  |    |    | US |
| x.04         | Fieldbus Baud Rate                      | -128 to +127                    |    |                          |    | 0       | RW   | Bi  |  |    |    | US |
| x.05         | Mode                                    | 65,535                          |    |                          |    | 4       | RW   | Uni |  |    |    | US |
| x.06         | Fieldbus Diagnostic                     | $\pm 9,999$                     |    |                          |    |         | RO   | Bi  |  | NC | PT |    |
| x.07         | Trip Delay Time                         | 0 to 3,000                      |    |                          |    | 200     | RW   | Uni |  |    |    | US |
| x.08         | Little endianism select                 | OFF (0) or On (1)               |    |                          |    | On (1)  | RW   | Bit |  |    |    | US |
| x.09         | Register control                        | OFF (0) or On (1)               |    |                          |    | OFF (0) | RW   | Bit |  |    |    | US |
| x.10 to x.19 | 'I' data registers 0 - 9                | -32,768 to +32,767              |    |                          |    |         | RW   | Bi  |  |    |    |    |
| x.20 to x.29 | 'O' data registers 0 - 9                | -32,768 to +32,767              |    |                          |    |         | RW   | Bi  |  |    |    |    |
| x.30         | Load Solutions Module defaults          | OFF (0) or On (1)               |    |                          |    | OFF (0) | RW   | Bit |  |    |    | US |
| x.31         | Save Solutions Module parameters        | OFF (0) or On (1)               |    |                          |    | OFF (0) | RW   | Bit |  |    |    | US |
| x.32         | Request to reinitialise                 | OFF (0) or On (1)               |    |                          |    | OFF (0) | RW   | Bit |  |    |    |    |
| x.33         | Download from Fieldbus Solutions Module | OFF (0) or On (1)               |    |                          |    | OFF (0) | RW   | Bit |  |    |    |    |
| x.34         | Compression                             | OFF (0) or On (1)               |    |                          |    | OFF (0) | RW   | Bit |  |    |    | US |
| x.35         | Serial number                           | -2,147,483,648 to 2,147,483,647 |    |                          |    |         | RO   | Bi  |  | NC | PT |    |
| x.36 to x.37 | Fieldbus specific                       | OFF (0) or On (1)               |    |                          |    | OFF (0) | RW   | Bit |  |    |    | US |
| x.38         | Fieldbus specific defined mode          | 0 to 255                        |    |                          |    | 0       | RW   | Uni |  |    |    | US |
| x.39         | Cyclic input configuration              | 0 to 255                        |    |                          |    | 0       | RW   | Uni |  |    |    | US |
| x.40         | Cyclic output configuration             | 0 to 255                        |    |                          |    | 0       | RW   | Uni |  |    |    | US |
| x.41 to x.43 | Fieldbus specific                       | 0 to 255                        |    |                          |    | 0       | RW   | Uni |  |    |    | US |
| x.44 to x.48 | Fieldbus specific                       | 0 to 255                        |    |                          |    | 0       | RO   | Uni |  |    | PT |    |
| x.49         | Mapping error status                    | 0 to 255                        |    |                          |    | 0       | RO   | Uni |  |    | PT |    |
| x.50         | Solutions Module error status*          | 0 to 255                        |    |                          |    |         | RO   | Uni |  | NC | PT |    |
| x.51         | Solutions Module software sub-version   | 0 to 99                         |    |                          |    |         | RO   | Uni |  | NC | PT |    |

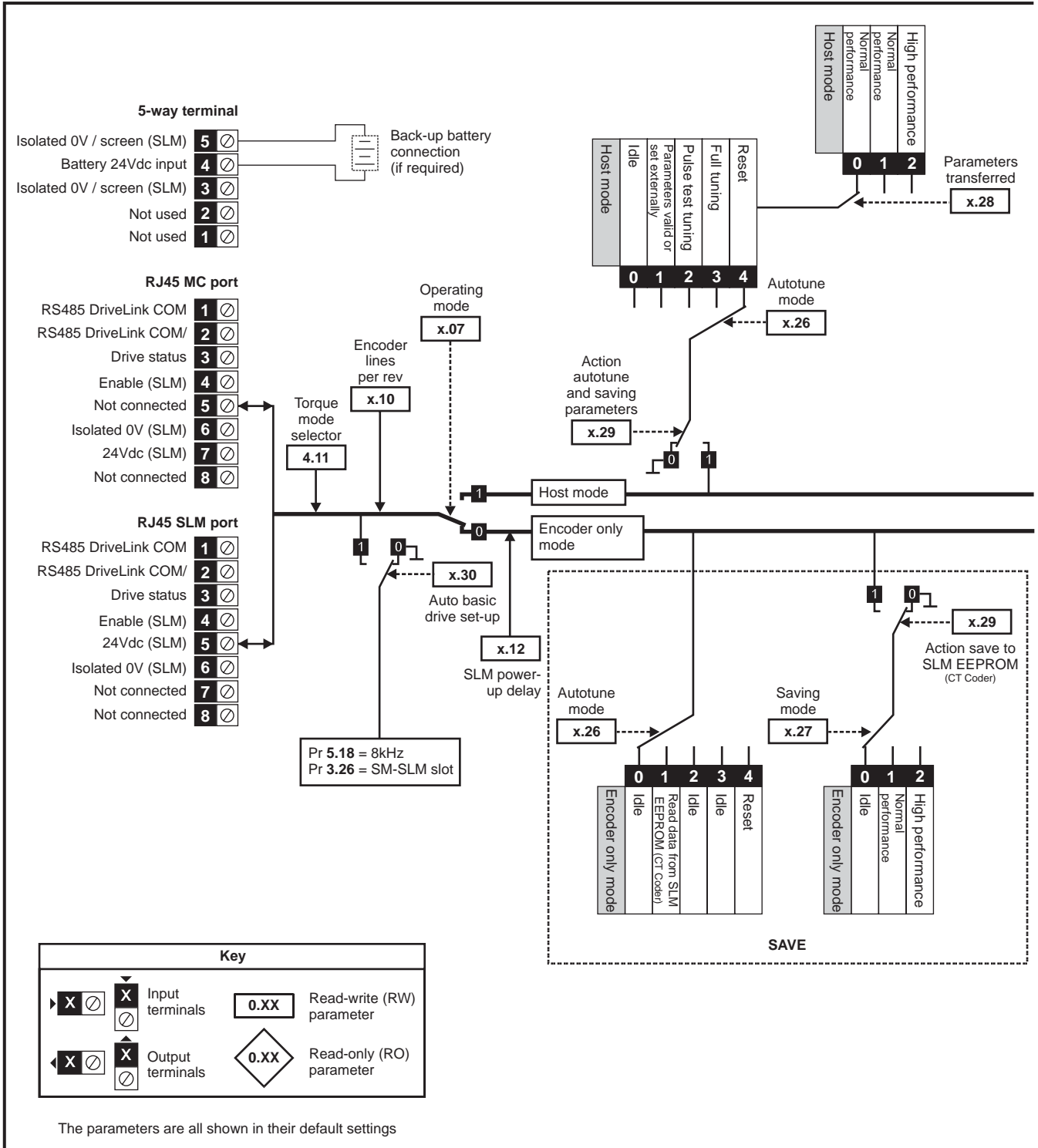
|    |              |    |             |     |            |    |                  |     |               |     |             |    |                 |
|----|--------------|----|-------------|-----|------------|----|------------------|-----|---------------|-----|-------------|----|-----------------|
| RW | Read / Write | RO | Read only   | Uni | Unipolar   | Bi | Bi-polar         | Bit | Bit parameter | Txt | Text string |    |                 |
| FI | Filtered     | DE | Destination | NC  | Not cloned | RA | Rating dependent | PT  | Protected     | US  | User save   | PS | Power down save |

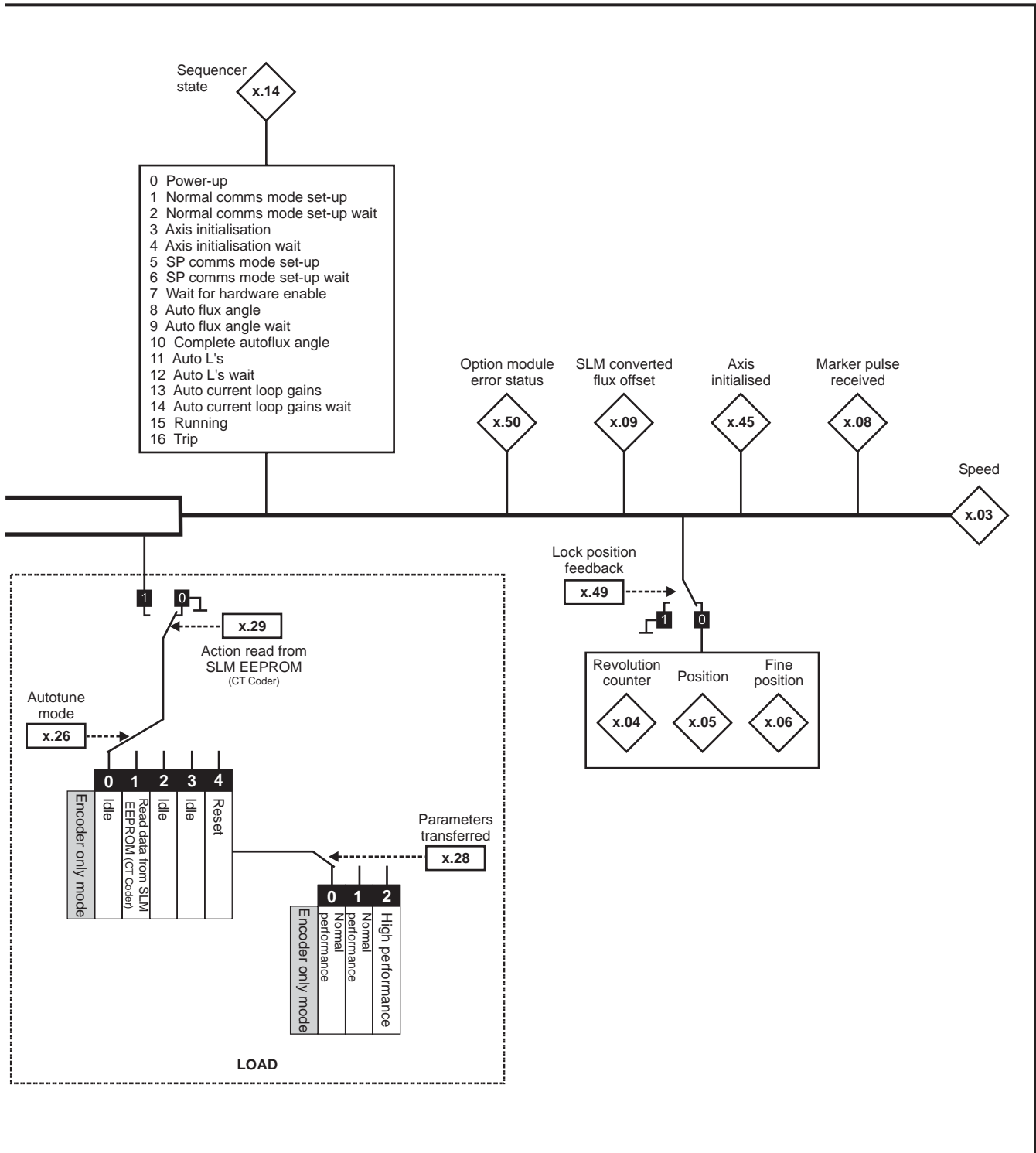
\*See trip SLX.Er, *Fieldbus module category* on page 286.



### 11.15.5 SLM module category

**Figure 11-40 SM-SLM logic diagram**





### SM-SLM parameters

| Parameter | Range(↕)                                |   | Default(⇔) |    |           | Type |     |    |  |    |    |    |
|-----------|---|---|------------|----|-----------|------|-----|----|--|----|----|----|
|           | OL                                      | CL  | OL         | VT | SV        |      |     |    |  |    |    |    |
| x.01      | Solutions Module ID                     | 0 to 499  |            |    |           | RO   | Uni |    |  | PT | US |    |
| x.02      | Solutions Module software version       | 0.0 to 99.99  |            |    |           | RO   | Uni |    |  | NC | PT |    |
| x.03      | Speed                                   | ±40,000.0 rpm   |            |    |           | RO   | Bi  | FI |  | NC | PT |    |
| x.04      | Revolution counter                      | 0 to 65,535 revolutions   |            |    |           | RO   | Uni | FI |  | NC | PT |    |
| x.05      | Position                                | 0 to 65,535 (1/2 <sup>16</sup> ths of a revolution)                           |            |    |           | RO   | Uni | FI |  | NC | PT |    |
| x.06      | Fine position                           | 0 to 65,535 (1/2 <sup>32</sup> nds of a revolution)                           |            |    |           | RO   | Uni | FI |  | NC | PT |    |
| x.07      | Operating mode                          | HoSt (0), Enc.Only (1)  |            |    | HoSt (0)  | RW   | Txt |    |  |    |    | US |
| x.08      | Marker pulse received indicator         | OFF (0) or On (1)   |            |    | OFF (0)   | RO   | Bit |    |  | NC |    |    |
| x.09      | SLM converted flux offset               | 0 to 65,535   |            |    | 0         | RO   | Uni |    |  |    |    |    |
| x.10      | Encoder lines per revolution            | 0 to 50,000   |            |    | 1024      | RW   | Uni |    |  |    |    | US |
| x.11      | SLM software version                    | 0.000 to 9.999  |            |    | 0.000     | RO   | Uni |    |  | NC | PT |    |
| x.12      | SLM power-up delay                      | 0.000 (0), 0.250 (1), 0.500 (2), 0.750 (3), 1.000 (4), 1.250 (5), 1.500 (6) s |            |    | 0.250 (1) | RW   | Txt |    |  |    |    | US |
| x.13      | Not used*                               |   |            |    |           |      |     |    |  |    |    |    |
| x.14      | Sequencer status                        | 0 to 16   |            |    |           | RO   | Uni |    |  | NC | PT |    |
| x.15      | Not used*                               |   |            |    |           |      |     |    |  |    |    |    |
| x.16      | Not used*                               |   |            |    |           |      |     |    |  |    |    |    |
| x.17      | Not used*                               |   |            |    |           |      |     |    |  |    |    |    |
| x.18      | Not used*                               |   |            |    |           |      |     |    |  |    |    |    |
| x.19      | Feedback filter                         | 0 (0), 1 (1), 2 (2), 4 (3), 8 (4), 16 (5) ms                                  |            |    | 0 (0)     | RW   | Txt |    |  |    |    | US |
| x.20      | Not used*                               |   |            |    |           |      |     |    |  |    |    |    |
| x.21      | Not used*                               |   |            |    |           |      |     |    |  |    |    |    |
| x.22      | Not used*                               |   |            |    |           |      |     |    |  |    |    |    |
| x.23      | Not used*                               |   |            |    |           |      |     |    |  |    |    |    |
| x.24      | Not used*                               |   |            |    |           |      |     |    |  |    |    |    |
| x.26      | Autotune mode                           | 0 to 4  |            |    | 0         | RW   | Uni |    |  |    |    | US |
| x.27      | Saving mode                             | 0 to 2  |            |    | 0         | RW   | Uni |    |  |    |    | US |
| x.28      | Parameters transferred                  | 0 to 2  |            |    | 0         | RW   | Uni |    |  |    |    | US |
| x.29      | Action the tuning and saving parameters | OFF (0) or On (1)   |            |    | OFF (0)   | RW   | Bit |    |  |    |    | US |
| x.30      | Automatic basic drive set-up request    | 0 to 1  |            |    | 0         | RW   | Uni |    |  |    |    | US |
| x.32      | Not used*                               |   |            |    |           |      |     |    |  |    |    |    |
| x.33      | Not used*                               |   |            |    |           |      |     |    |  |    |    |    |
| x.34      | Not used*                               |   |            |    |           |      |     |    |  |    |    |    |
| x.35      | Not used*                               |   |            |    |           |      |     |    |  |    |    |    |
| x.36      | Not used*                               |   |            |    |           |      |     |    |  |    |    |    |
| x.37      | Not used*                               |   |            |    |           |      |     |    |  |    |    |    |
| x.38      | Not used*                               |   |            |    |           |      |     |    |  |    |    |    |
| x.39      | Not used*                               |   |            |    |           |      |     |    |  |    |    |    |
| x.40      | Not used*                               |   |            |    |           |      |     |    |  |    |    |    |
| x.41      | Not used*                               |   |            |    |           |      |     |    |  |    |    |    |
| x.42      | Not used*                               |   |            |    |           |      |     |    |  |    |    |    |
| x.43      | Not used*                               |   |            |    |           |      |     |    |  |    |    |    |
| x.44      | Not used*                               |   |            |    |           |      |     |    |  |    |    |    |
| x.45      | Axis initialised                        | OFF (0) or On (1)   |            |    |           | RO   | Bit |    |  |    | PT |    |
| x.46      | Not used*                               |   |            |    |           |      |     |    |  |    |    |    |
| x.47      | Not used*                               |   |            |    |           |      |     |    |  |    |    |    |
| x.48      | Not used*                               |   |            |    |           |      |     |    |  |    |    |    |
| x.49      | Lock position feedback                  | OFF (0) or On (1)   |            |    | OFF (0)   | RW   | Bit |    |  |    | PT |    |
| x.50      | Solutions Module error status**         | 0 to 255  |            |    |           | RO   | Uni |    |  | NC | PT |    |
| x.51      | Solutions Module software sub-version   | 0 to 99   |            |    |           | RO   | Uni |    |  | NC | PT |    |

|    |              |    |             |     |            |    |                  |     |               |     |             |    |                 |
|----|--------------|----|-------------|-----|------------|----|------------------|-----|---------------|-----|-------------|----|-----------------|
| RW | Read / Write | RO | Read only   | Uni | Unipolar   | Bi | Bi-polar         | Bit | Bit parameter | Txt | Text string |    |                 |
| FI | Filtered     | DE | Destination | NC  | Not cloned | RA | Rating dependent | PT  | Protected     | US  | User save   | PS | Power down save |

\* Some of the parameters which are not used will be introduced in scheduled product enhancement.

\*\*See trip SLX.Er, *SLM module category* on page 287.

## 11.16 Menu 18: Application menu 1

| Parameter  | Range( $\hat{\updownarrow}$ ) |    | Default( $\Leftrightarrow$ ) |    |    | Type |     |  |    |  |    |
|--|-------------------------------|----|------------------------------|----|----|------|-----|--|----|--|----|
|  | OL                            | CL | OL                           | VT | SV |      |     |  |    |  |    |
| 18.01 Application menu 1 power-down saved integer    | -32,768 to +32,767            |    | 0                            |    |    | RW   | Bi  |  | NC |  | PS |
| 18.02 to 18.10 Application menu 1 read-only integer  | -32,768 to +32,767            |    | 0                            |    |    | RO   | Bi  |  | NC |  |    |
| 18.11 to 18.30 Application menu 1 read-write integer | -32,768 to +32,767            |    | 0                            |    |    | RW   | Bi  |  |    |  | US |
| 18.31 to 18.50 Application menu 1 read-write bit     | OFF (0) or On (1)             |    | 0                            |    |    | RW   | Bit |  |    |  | US |

## 11.17 Menu 19: Application menu 2

| Parameter  | Range( $\hat{\updownarrow}$ ) |    | Default( $\Leftrightarrow$ ) |    |    | Type |     |  |    |  |    |
|--|-------------------------------|----|------------------------------|----|----|------|-----|--|----|--|----|
|  | OL                            | CL | OL                           | VT | SV |      |     |  |    |  |    |
| 19.01 Application menu 2 power-down saved integer    | -32,768 to +32,767            |    | 0                            |    |    | RW   | Bi  |  | NC |  | PS |
| 19.02 to 19.10 Application menu 2 read-only integer  | -32,768 to +32,767            |    | 0                            |    |    | RO   | Bi  |  | NC |  |    |
| 19.11 to 19.30 Application menu 2 read-write integer | -32,768 to +32,767            |    | 0                            |    |    | RW   | Bi  |  |    |  | US |
| 19.31 to 19.50 Application menu 2 read-write bit     | OFF (0) or On (1)             |    | 0                            |    |    | RW   | Bit |  |    |  | US |

## 11.18 Menu 20: Application menu 3

| Parameter   | Range( $\hat{\updownarrow}$ ) |    | Default( $\Leftrightarrow$ ) |    |    | Type |    |  |    |  |  |
|---|-------------------------------|----|------------------------------|----|----|------|----|--|----|--|--|
|   | OL                            | CL | OL                           | VT | SV |      |    |  |    |  |  |
| 20.01 to 20.20 Application menu 3 read-write integer      | -32,768 to +32,767            |    | 0                            |    |    | RW   | Bi |  | NC |  |  |
| 20.21 to 20.40 Application menu 3 read-write long integer | $-2^{31}$ to $2^{31}-1$       |    | 0                            |    |    | RW   | Bi |  | NC |  |  |

With software V01.07.00 and later, all menu 20 parameters are transferred to the SMARTCARD when a 4yyy transfer is performed. See section 9.2.1 *Writing to the SMARTCARD* on page 152 for more information.

|    |              |    |             |     |            |    |                  |     |               |     |             |    |                 |
|----|--------------|----|-------------|-----|------------|----|------------------|-----|---------------|-----|-------------|----|-----------------|
| RW | Read / Write | RO | Read only   | Uni | Unipolar   | Bi | Bi-polar         | Bit | Bit parameter | Txt | Text string |    |                 |
| FI | Filtered     | DE | Destination | NC  | Not cloned | RA | Rating dependent | PT  | Protected     | US  | User save   | PS | Power down save |


## 11.19 Menu 21: Second motor parameters

| Parameter                                       | Range(⇅)  |   | Default(⇄)   |   |            | Type |     |  |    |       |
|---|---|---|--|---|------------|------|-----|--|----|-------|
|   | OL  | CL  | OL   | VT  | SV         |      |     |  |    |       |
| 21.01 Maximum reference clamp (0.02)*           | 0 to 3,000.0 Hz   | SPEED_LIMIT_MAX rpm                                     | EUR> 50.0<br>USA> 60.0   | EUR> 1,500.0<br>USA> 1,800.0                          | 3,000.0    | RW   | Uni |  |    | US    |
| 21.02 Minimum reference clamp (0.01)*           | ±3,000.0 Hz   | ±SPEED_LIMIT_MAX rpm                                    | 0.0  |   |            | RW   | Bi  |  |    | PT US |
| 21.03 Reference selector (0.05)*                | A1.A2 (0), A1.Pr (1), A2.Pr (2), Pr (3), PAd (4), Prc (5)         |   | A1.A2 (0)  |   |            | RW   | Txt |  |    | US    |
| 21.04 Acceleration rate (0.03)*                 | 0.0 to 3,200.0 s/100Hz  | 0.000 to 3,200.000 s/1000rpm                            | 5.0  | 2.000   | 0.200      | RW   | Uni |  |    | US    |
| 21.05 Deceleration rate (0.04)*                 | 0.0 to 3200.0 s/100Hz   | 0.000 to 3,200.000 s/1000rpm                            | 10.0   | 2.000   | 0.200      | RW   | Uni |  |    | US    |
| 21.06 Rated frequency (0.47)*                   | 0 to 3000.0 Hz  | VT> 0 to 1250.0Hz                                       | EUR> 50<br>USA> 60   |   |            | RW   | Uni |  |    | US    |
| 21.07 Rated current (0.46)*                     | 0 to RATED_CURRENT_MAX A  |   | Drive rated current (Pr 11.32)   |   |            | RW   | Uni |  | RA | US    |
| 21.08 Rated load rpm (0.45)*                    | 0 to 180,000 rpm  | 0.00 to 40,000.00 rpm                                   | EUR> 1,500<br>USA> 1,800   | EUR> 1,450.00<br>USA> 1,770.00                        | 3,000.00   | RW   | Uni |  |    | US    |
| 21.09 Rated voltage (0.44)*                     | 0 to AC_VOLTAGE_SET_MAX V   |   | 200V rating drive: 230V<br>400V rating drive: EUR> 400V, USA> 460V<br>575V rating drive: 575V<br>690V rating drive: 690V |   |            | RW   | Uni |  | RA | US    |
| 21.10 Rated power factor (0.43)*                | 0.000 to 1.000  | VT> 0.000 to 1.000                                      | 0.85   |   |            | RW   | Uni |  | RA | US    |
| 21.11 Number of motor poles (0.42)*             | Auto to 120 pole (0 to 60)  |   | Auto (0)   |   | 6 POLE (3) | RW   | Txt |  |    | US    |
| 21.12 Stator resistance                         | Size 1 to 5: 0.000 to 65.000 Ω<br>Size 6: 0.000 to 65.000 x 10 mΩ |   | 0.0  |   |            | RW   | Uni |  | RA | US    |
| 21.13 Voltage offset                            | 0.0 to 25.0 V   |   | 0.0  |   |            | RW   | Uni |  | RA | US    |
| 21.14 Transient inductance (σL <sub>s</sub> )   | 0.000 to 500.000mH  |   | 0.000  |   |            | RW   | Uni |  | RA | US    |
| 21.15 Motor 2 active                            | OFF (0) or On (1)   |   |  |   |            | RO   | Bit |  | NC | PT    |
| 21.16 Thermal time constant (0.45)*             | 0.0 to 3000.0   |   | 89.0   |   | 20.0       | RW   | Uni |  |    | US    |
| 21.17 Speed controller Kp gain (0.07)*          |   | 0.000 to 6.5535 rad s <sup>-1</sup>                     |  |   | 0.0100     | RW   | Uni |  |    | US    |
| 21.18 Speed controller Ki gain (0.08)*          |   | 0.00 to 655.35 s/rad s <sup>-1</sup>                    |  |   | 1.00       | RW   | Uni |  |    | US    |
| 21.19 Speed controller Kd gain (0.09)*          |   | 0.00000 to 0.65535 s <sup>-1</sup> /rad s <sup>-1</sup> |  |   | 0.00000    | RW   | Uni |  |    | US    |
| 21.20 Encoder phase angle (0.43)*               |   | 0.0 to 359.9 ° electrical                               |  |   | 0.0        | RW   | Uni |  |    | US    |
| 21.21 Speed feedback selector                   |   | drv (0), SLOt1 (1), SLOt2 (2), SLOt3 (3)                | drv (0)  |   |            | RW   | Txt |  |    | US    |
| 21.22 Current controller Kp gain (0.38)*        | 0 to 30,000   |   | 20   | 200V: 75, 400V: 150,<br>575V: 180, 690V: 215          |            | RW   | Uni |  |    | US    |
| 21.23 Current controller Ki gain (0.39)*        | 0 to 30,000   |   | 40   | 200V: 1,000, 400V: 2,000,<br>575V: 2,400, 690V: 3,000 |            | RW   | Uni |  |    | US    |
| 21.24 Stator inductance (L <sub>s</sub> )       |   | VT> 0.00 to 5,000.00 mH                                 |  |   | 0.00       | RW   | Uni |  | RA | US    |
| 21.25 Motor saturation breakpoint 1             |   | VT> 0 to 100% of rated flux                             |  |   | 50         | RW   | Uni |  |    | US    |
| 21.26 Motor saturation breakpoint 2             |   | VT> 0 to 100% of rated flux                             |  |   | 75         | RW   | Uni |  |    | US    |
| 21.27 Motoring current limit                    | 0 to MOTOR2_CURRENT_LIMIT_MAX %                                   |   | 165.0  | 175.0   |            | RW   | Uni |  | RA | US    |
| 21.28 Regen current limit                       | 0 to MOTOR2_CURRENT_LIMIT_MAX %                                   |   | 165.0  | 175.0   |            | RW   | Uni |  | RA | US    |
| 21.29 Symmetrical current limit (0.06)*         | 0 to MOTOR2_CURRENT_LIMIT_MAX %                                   |   | 165.0  | 175.0   |            | RW   | Uni |  | RA | US    |
| 21.30 Motor volts per 1,000 rpm, K <sub>e</sub> |   | SV> 0 to 10,000 V                                       |  |   | 98         | RW   | Uni |  |    | US    |
| 21.31 Motor pole pitch                          | 0.00 to 655.35 mm   |   | 0.00   |   |            | RW   | Uni |  |    | US    |

|    |              |    |             |     |            |    |                  |     |               |     |             |    |                 |
|----|--------------|----|-------------|-----|------------|----|------------------|-----|---------------|-----|-------------|----|-----------------|
| RW | Read / Write | RO | Read only   | Uni | Unipolar   | Bi | Bi-polar         | Bit | Bit parameter | Txt | Text string |    |                 |
| FI | Filtered     | DE | Destination | NC  | Not cloned | RA | Rating dependent | PT  | Protected     | US  | User save   | PS | Power down save |

\* The menu 0 references are only valid when the second motor map parameters have been made active by setting Pr 11.45 to 1. (The second motor map only becomes effective when the output stage of the drive is not enabled, i.e. inh, rdY, or trip states.)

When the second motor map parameters are active, the decimal point that is second from the right on the first row of the LED display is on.



**Encoder phase angle (servo mode only)**

With drive software version V01.08.00 onwards, the encoder phase angles in Pr 3.25 and Pr 21.20 are cloned to the SMARTCARD when using any of the SMARTCARD transfer methods.

With drive software version V01.05.00 to V01.07.01, the encoder phase angles in Pr 3.25 and Pr 21.20 are only cloned to the SMARTCARD when using either Pr 0.30 set to Prog (2) or Pr xx.00 set to 3yyy.

This is useful when the SMARTCARD is used to back-up the parameter set of a drive but caution should be used if the SMARTCARD is used to transfer parameter sets between drives.

Unless the encoder phase angle of the servo motor connected to the destination drive is known to be the same as the servo motor connected to the source drive, an autotune should be performed or the encoder phase angle should be entered manually into Pr 3.25 (or Pr 21.20). If the encoder phase angle is incorrect the drive may lose control of the motor resulting in an O.SPd or Enc10 trip when the drive is enabled.

With drive software version V01.04.00 and earlier, or when using software version V01.05.00 to V01.07.01 and Pr xx.00 set to 4yyy is used, then the encoder phase angles in Pr 3.25 and Pr 21.20 are not cloned to the SMARTCARD. Therefore, Pr 3.25 and Pr 21.20 in the destination would not be changed during a transfer of this data block from the SMARTCARD.

## 11.20 Menu 22: Additional Menu 0 set-up

| Parameter | Range(⇅)              |    | Default(⇔)          |    |    | Type     |         |         |    |     |  |  |    |    |
|-----------|-----------------------|----|---------------------|----|----|----------|---------|---------|----|-----|--|--|----|----|
|           | OL                    | CL | OL                  | VT | SV |          |         |         |    |     |  |  |    |    |
| 22.01     | Parameter 0.31 set-up |    | Pr 1.00 to Pr 21.51 |    |    | Pr 11.33 |         |         | RW | Uni |  |  | PT | US |
| 22.02     | Parameter 0.32 set-up |    | Pr 1.00 to Pr 21.51 |    |    | Pr 11.32 |         |         | RW | Uni |  |  | PT | US |
| 22.03     | Parameter 0.33 set-up |    | Pr 1.00 to Pr 21.51 |    |    | Pr 6.09  | Pr 5.16 | Pr 0.00 | RW | Uni |  |  | PT | US |
| 22.04     | Parameter 0.34 set-up |    | Pr 1.00 to Pr 21.51 |    |    | Pr 11.30 |         |         | RW | Uni |  |  | PT | US |
| 22.05     | Parameter 0.35 set-up |    | Pr 1.00 to Pr 21.51 |    |    | Pr 11.24 |         |         | RW | Uni |  |  | PT | US |
| 22.06     | Parameter 0.36 set-up |    | Pr 1.00 to Pr 21.51 |    |    | Pr 11.25 |         |         | RW | Uni |  |  | PT | US |
| 22.07     | Parameter 0.37 set-up |    | Pr 1.00 to Pr 21.51 |    |    | Pr 11.23 |         |         | RW | Uni |  |  | PT | US |
| 22.10     | Parameter 0.40 set-up |    | Pr 1.00 to Pr 21.51 |    |    | Pr 5.12  |         |         | RW | Uni |  |  | PT | US |
| 22.11     | Parameter 0.41 set-up |    | Pr 1.00 to Pr 21.51 |    |    | Pr 5.18  |         |         | RW | Uni |  |  | PT | US |
| 22.18     | Parameter 0.48 set-up |    | Pr 1.00 to Pr 21.51 |    |    | Pr 11.31 |         |         | RW | Uni |  |  | PT | US |
| 22.20     | Parameter 0.50 set-up |    | Pr 1.00 to Pr 21.51 |    |    | Pr 11.29 |         |         | RW | Uni |  |  | PT | US |
| 22.21     | Parameter 0.51 set-up |    | Pr 1.00 to Pr 21.51 |    |    | Pr 0.00  |         |         | RW | Uni |  |  | PT | US |
| 22.22     | Parameter 0.52 set-up |    | Pr 1.00 to Pr 21.51 |    |    | Pr 0.00  |         |         | RW | Uni |  |  | PT | US |
| 22.23     | Parameter 0.53 set-up |    | Pr 1.00 to Pr 21.51 |    |    | Pr 0.00  |         |         | RW | Uni |  |  | PT | US |
| 22.24     | Parameter 0.54 set-up |    | Pr 1.00 to Pr 21.51 |    |    | Pr 0.00  |         |         | RW | Uni |  |  | PT | US |
| 22.25     | Parameter 0.55 set-up |    | Pr 1.00 to Pr 21.51 |    |    | Pr 0.00  |         |         | RW | Uni |  |  | PT | US |
| 22.26     | Parameter 0.56 set-up |    | Pr 1.00 to Pr 21.51 |    |    | Pr 0.00  |         |         | RW | Uni |  |  | PT | US |
| 22.27     | Parameter 0.57 set-up |    | Pr 1.00 to Pr 21.51 |    |    | Pr 0.00  |         |         | RW | Uni |  |  | PT | US |
| 22.28     | Parameter 0.58 set-up |    | Pr 1.00 to Pr 21.51 |    |    | Pr 0.00  |         |         | RW | Uni |  |  | PT | US |
| 22.29     | Parameter 0.59 set-up |    | Pr 1.00 to Pr 21.51 |    |    | Pr 0.00  |         |         | RW | Uni |  |  | PT | US |

|    |              |    |             |     |            |    |                  |     |               |     |             |    |                 |
|----|--------------|----|-------------|-----|------------|----|------------------|-----|---------------|-----|-------------|----|-----------------|
| RW | Read / Write | RO | Read only   | Uni | Unipolar   | Bi | Bi-polar         | Bit | Bit parameter | Txt | Text string |    |                 |
| Fl | Filtered     | DE | Destination | NC  | Not cloned | RA | Rating dependent | PT  | Protected     | US  | User save   | PS | Power down save |

## 11.21 Advanced features

This section gives information on some of the advanced functions of the Unidrive SP. For additional information see the *Unidrive SP Advanced User Guide*.

|                        |                                       |
|------------------------|---------------------------------------|
| Reference modes        | Pr 1.14, Pr 1.15 and Pr 8.39          |
| Braking modes          | Pr 2.04 and Pr 2.08                   |
| S ramps                | Pr 2.06 and Pr 2.07                   |
| Torque modes           | Pr 4.08 and Pr 4.11                   |
| Stop modes             | Pr 6.01, Pr 6.06, Pr 6.07 and Pr 6.08 |
| Main loss modes        | Pr 6.03, Pr 6.48, Pr 4.13 and Pr 4.14 |
| Start/stop logic modes | Pr 6.04 and Pr 6.40                   |
| Catch a spinning motor | Pr 6.09 and Pr 5.40                   |
| Position loop modes    | Pr 13.10                              |

### 11.21.1 Reference modes

| 1.14 |   | Reference selector |           |  |  |    |    |
|------|---|--------------------|-----------|--|--|----|----|
| RW   | Txt   |                    |           |  |  | NC | US |
| ↕    | A1.A2 (0), A1.Pr (2), A2.Pr (2), Pr (3), PAd (4), Prc (5) | ⇒                  | A1.A2 (0) |  |  |    |    |

| 1.15 |        | Preset reference selector |   |  |  |    |    |
|------|--------|---------------------------|---|--|--|----|----|
| RW   | Uni    |                           |   |  |  | NC | US |
| ↕    | 0 to 9 | ⇒                         | 0 |  |  |    |    |

| 8.39 |                   | T28 and T29 auto-selection |         |  |  |    |  |
|------|-------------------|----------------------------|---------|--|--|----|--|
| RW   | Bit               |                            |         |  |  | US |  |
| ↕    | OFF (0) or On (1) | ⇒                          | OFF (0) |  |  |    |  |

The setting of Pr 1.14 automatically changes the operation of digital inputs T28 and T29 by configuring the destination parameters Pr 8.25 and Pr 8.26. To allow Pr 8.25 and Pr 8.26 to be changed manually by the user, the automatic set-up must be disabled by setting Pr 8.39 to 1.

If Pr 8.39 is 0 and Pr 1.14 is changed, then a drive reset is required before the function of terminal T28 or T29 will become active.

Table 11-8 Active reference

| Pr 1.14   | Pr 1.15     | Digital Input T28 |                     | Digital Input T29 |                         | Pr 1.49                 | Pr 1.50                 | Active Reference        |  |
|-----------|-------------|-------------------|---------------------|-------------------|-------------------------|-------------------------|-------------------------|-------------------------|--|
|           |             | State             | Function            | State             | Function                |                         |                         |                         |  |
| A1.A2 (0) | 0 or 1      | 0                 | Local Remote        |                   | Jog forward**           | 1                       | 1                       | Analogue input 1        |  |
|           |             | 1                 |                     |                   |                         | 2                       | 1                       | Analogue input 2        |  |
|           | 2 to 8      |                   | No function         |                   |                         | 1 or 2                  | 2 to 8                  | Preset reference 2 to 8 |  |
|           | 9 *         | 0                 | Local Remote        |                   |                         | 1                       | 1                       | Analogue input 1        |  |
|           |             | 1                 |                     |                   |                         | 2                       | 1                       | Analogue input 2        |  |
| 9 *       |             | No function       | 1 or 2              | 2 to 8            | Preset reference 2 to 8 |                         |                         |                         |  |
| A1.Pr (1) | 0           | 0                 | Preset select bit 0 | 0                 | Preset select bit 1     | 1                       | 1                       | Analogue input 1        |  |
|           |             | 1                 |                     |                   |                         |                         | 2                       | Preset reference 2      |  |
|           |             | 0                 |                     | 3                 |                         |                         | Preset reference 3      |                         |  |
|           |             | 1                 |                     | 4                 |                         |                         | Preset reference 4      |                         |  |
|           | 2 to 8      |                   | No function         |                   | 1                       |                         | Analogue input 1        |                         |  |
|           | 9 *         | No function       |                     |                   | 2 to 8                  |                         | Preset reference 2 to 8 |                         |  |
|           |             | No function       |                     |                   | 1                       |                         | Analogue input 1        |                         |  |
| A2.Pr (2) | 0           | 0                 | Preset select bit 0 | 0                 | Preset select bit 1     | 2                       | 2 to 8                  | Preset reference 2 to 8 |  |
|           |             | 1                 |                     |                   |                         |                         | 1                       | Analogue input 2        |  |
|           |             | 0                 |                     | 2                 |                         |                         | Preset reference 2      |                         |  |
|           |             | 1                 |                     | 3                 |                         |                         | Preset reference 3      |                         |  |
|           | 2 to 8      |                   | No function         |                   |                         |                         | 4                       | Preset reference 4      |  |
|           | 9 *         | No function       |                     |                   |                         |                         | 1                       | Analogue input 2        |  |
|           |             | No function       |                     |                   |                         |                         | 2 to 8                  | Preset reference 2 to 8 |  |
| Pr (3)    | 0           | 0                 | Preset select bit 0 | 0                 | Preset select bit 1     | 3                       | 1                       | Preset reference 1      |  |
|           |             | 1                 |                     |                   |                         |                         | 2                       | Preset reference 2      |  |
|           |             | 0                 |                     | 3                 |                         |                         | Preset reference 3      |                         |  |
|           |             | 1                 |                     | 4                 |                         |                         | Preset reference 4      |                         |  |
|           | 1 to 8      |                   | No function         |                   |                         |                         | 1 to 8                  | Preset reference 1 to 8 |  |
| 9 *       | No function |                   |                     |                   | 1 to 8                  | Preset reference 1 to 8 |                         |                         |  |
| PAd (4)   |             | No function       |                     |                   | No function             | 4                       |                         | Keypad reference        |  |
| Prc (5)   |             | No function       |                     |                   | No function             | 5                       |                         | Precision reference     |  |

\* Setting Pr 1.15 to 9 enables the Preset reference scan timer. With the scan timer enabled the preset references are selected automatically in turn. Pr 1.16 defines the time between each change.

\*\* Jog forward can only be selected when the drive is in either the ready (rdy), inhibit (inh) or trip states.

## Preset references

Preset references 1 to 8 are contained in Pr 1.21 to Pr 1.28.

## Keypad reference

If Keypad reference is selected the drive sequencer is controlled directly by the keypad keys and the keypad reference parameter (Pr 1.17) is selected. The sequencing bits, Pr 6.30 to Pr 6.34, and Pr 6.37 have no effect and jog is disabled.

## Precision reference

If Precision reference is selected the speed reference is given Pr 1.18 and Pr 1.19.

## 11.21.2 Braking Modes

| 2.04 |     | Ramp mode select              |           |
|------|-----|-------------------------------|-----------|
| RW   | Uni | RA                            | US        |
| OL   | ↕   | FAST (0), Std (1), Std.hV (2) | ⇒ Std (1) |
| CL   |     | FAST (0), Std (1)             |           |

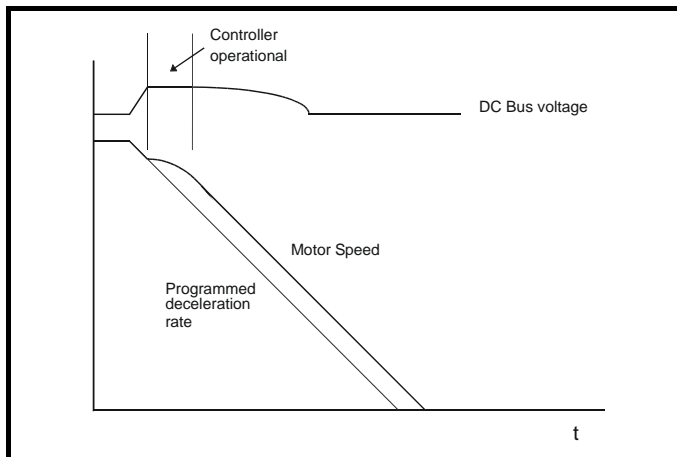
This parameter does not affect the acceleration ramp, as the ramp output always rises at the programmed acceleration rate subject to the current limits. It is possible in under some unusual circumstances in open-loop mode (i.e. highly inductive supply) for the motor to reach a low speed in standard ramp mode, but not completely stop. It is also possible if the drive attempts to stop the motor with an overhauling load in any mode that the motor will not stop when standard ramp mode or fast ramp mode is used. If the drive is in the deceleration state the rate of fall of the frequency or speed is monitored. If this does not fall for 10 seconds the drive forces the frequency or the speed reference to zero. This only applies when the drive is in the deceleration state and not when the reference is simply set to zero.

### 0: Fast ramp

Fast ramp is used where the deceleration follows the programmed deceleration rate subject to current limits.

### 1: Standard ramp

Standard ramp is used. During deceleration, if the voltage rises to the standard ramp level (Pr 2.08) it causes a controller to operate, the output of which changes the demanded load current in the motor. As the controller regulates the link voltage, the motor deceleration increases as the speed approaches zero speed. When the motor deceleration rate reaches the programmed deceleration rate the controller ceases to operate and the drive continues to decelerate at the programmed rate. If the standard ramp voltage (Pr 2.08) is set lower than the nominal DC Bus level the drive will not decelerate the motor, but it will coast to rest. The output of the ramp controller (when active) is a current demand that is fed to the frequency changing current controller (Open-loop modes) or the torque producing current controller (Closed-loop vector or Servo modes). The gain of these controllers can be modified with Pr 4.13 and Pr 4.14.



## 2: Standard ramp with motor voltage boost

This mode is the same as normal standard ramp mode except that the motor voltage is boosted by 20%. This increases the losses in the motor giving faster deceleration.

| 2.08 |     | Standard ramp voltage     |  |
|------|-----|---------------------------|--|
| RW   | Uni | RA                        | US   |
| ↕    |     | 0 to DC_VOLTAGE_SET_MAX V | ⇒  |
|      |     |                           | 200V drive: 375<br>400V drive: EUR> 750<br>USA> 775<br>575V drive: 895<br>690V drive: 1075 |

This voltage is used as the control level for standard ramp mode. If this parameter is set too low the machine will coast to rest, and if it is set too high and no braking resistor is used the drive may give an over-volt 'OV' trip. The minimum level should be greater than the voltage produced on the DC Bus by the highest supply voltage. Normally the DC Bus voltage will be approximately the rms supply line voltage x  $\sqrt{2}$ .



Care should be taken in the setting of this parameter. It is recommended that the setting should be at least 50V higher than the maximum expected level of the DC Bus voltage. If this is not done, the motor may fail to decelerate on a STOP command.

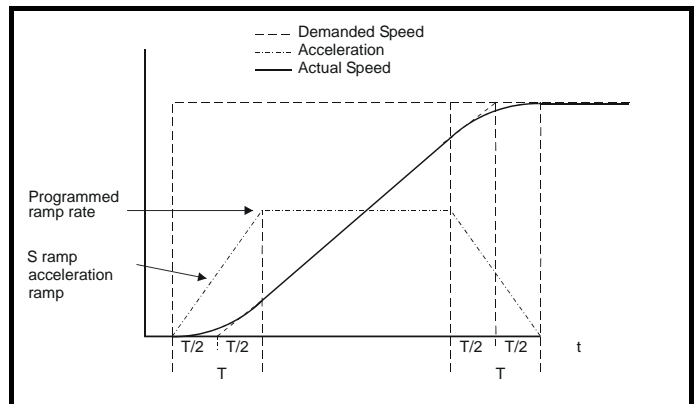
## 11.21.3 S ramps

| 2.06 |     | S ramp enable     |           |
|------|-----|-------------------|-----------|
| RW   | Bit | RA                | US        |
| ↕    |     | OFF (0) or On (1) | ⇒ OFF (0) |

Setting this parameter enables the S ramp function. S ramp is disabled during deceleration using standard ramp. When the motor is accelerated again after decelerating in standard ramp the acceleration ramp used by the S ramp function is reset to zero.

| 2.07 |     | S ramp acceleration limit   |       |
|------|-----|-----------------------------|-------|
| RW   | Uni | RA                          | US    |
| OL   | ↕   | 0.0 to 300.0<br>$s^2/100Hz$ | ⇒ 3.1 |
| VT   |     | 0.000 to 100.000            | 1.500 |
| SV   |     | $s^2/1000rpm$               | 0.030 |

This parameter defines the maximum rate of change of acceleration/ deceleration. The default values have been chosen such that for the default ramps and maximum speed, the curved parts of the S will be 25% of the original ramp if S ramp is enabled.



Since the ramp rate is defined in s/100Hz or s/1000rpm and the S ramp parameter is defined in s<sup>2</sup>/100Hz or s<sup>2</sup>/1000rpm, the time T for the 'curved' part of the S can be determined from:

$$T = S \text{ ramp rate of change} / \text{Ramp rate}$$

Enabling S ramp increases the total ramp time by the period T since an additional T/2 is added to each end of the ramp in producing the S.

### 11.21.4 Torque modes

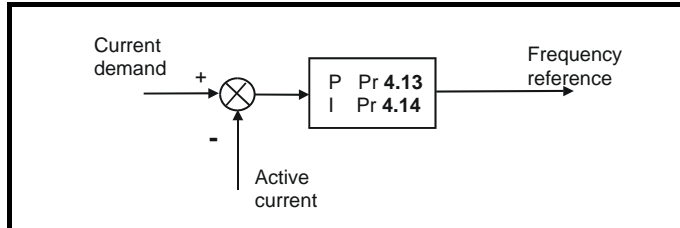
| 4.08 |    | Torque reference    |  |  |  |  |  |  |  |  |  |   |      |
|------|----|---------------------|--|--|--|--|--|--|--|--|--|---|------|
| RW   | Bi |                     |  |  |  |  |  |  |  |  |  |   | US   |
| ↕    |    | ±USER_CURRENT_MAX % |  |  |  |  |  |  |  |  |  | ⇒ | 0.00 |

Parameter for main torque reference. The normal update rate for the torque reference is 4ms. However if analogue inputs 2 or 3 on the drive are used as the source of the reference, the drive is in closed-loop vector or servo mode and the analogue inputs are in voltage mode with zero offset, the sample time is reduced to 250µs.

| 4.11 |     | Torque mode selector |  |  |  |  |  |  |  |  |  |   |    |
|------|-----|----------------------|--|--|--|--|--|--|--|--|--|---|----|
| RW   | Uni |                      |  |  |  |  |  |  |  |  |  |   | US |
| OL   | ↕   | 0 to 1               |  |  |  |  |  |  |  |  |  | ⇒ | 0  |
| CL   | ↕   | 0 to 4               |  |  |  |  |  |  |  |  |  | ⇒ |    |

#### Open loop

If this parameter is 0 normal frequency control is used. If this parameter is set to 1 the current demand is connected to the current PI controller giving closed loop torque/current demand as shown below. The current error is passed through proportional and integral terms to give a frequency reference which is limited to the range: -SPEED\_FREQ\_MAX to +SPEED\_FREQ\_MAX.



#### Closed loop vector and Servo

When this parameter is set to 1, 2 or 3 the ramps are not active whilst the drive is in the run state. When the drive is taken out of the run state, but not disabled, the appropriate stopping mode is used. It is recommended that coast stopping or stopping without ramps are used. However, if ramp stop mode is used the ramp output is pre-loaded with the actual speed at the changeover point to avoid unwanted jumps in the speed reference.

#### 0: Speed control mode

The torque demand is equal to the speed loop output.

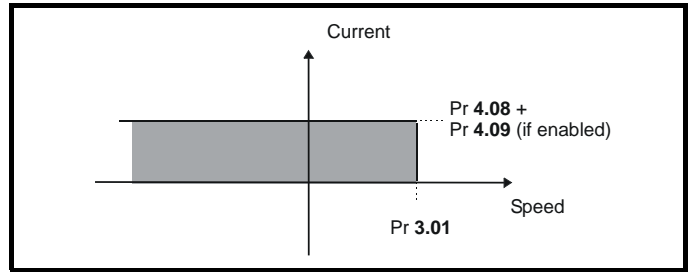
#### 1: Torque control

The torque demand is given by the sum of the torque reference and the torque offset, if enabled. The speed is not limited in any way, however, the drive will trip at the overspeed threshold if runaway occurs.

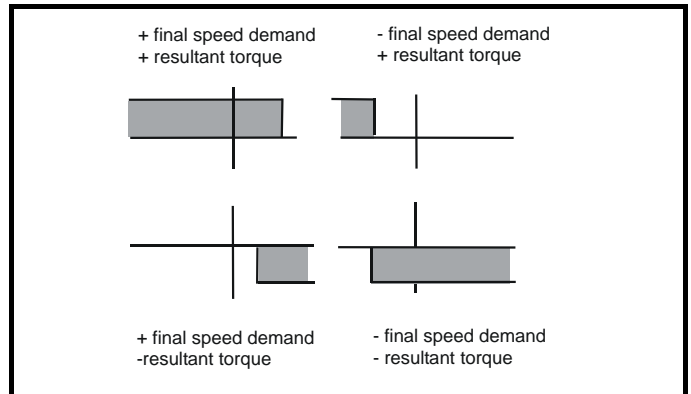
#### 2: Torque control with speed override

The output of the speed loop defines the torque demand, but is limited between 0 and the resultant torque reference (Pr 4.08 and Pr 4.09 (if enabled)). The effect is to produce an operating area as shown below if the final speed demand and the resultant torque reference are both positive. The speed controller will try and accelerate the machine to the final speed demand level with a torque demand defined by the resultant torque reference. However,

the speed cannot exceed the reference because the required torque would be negative, and so it would be clamped to zero.



Depending on the sign of the final speed demand and the resultant torque the four areas of operation shown below are possible.



This mode of operation can be used where torque control is required, but the maximum speed must be limited by the drive.

#### 3: Coiler/uncoiler mode

Positive final speed demand:

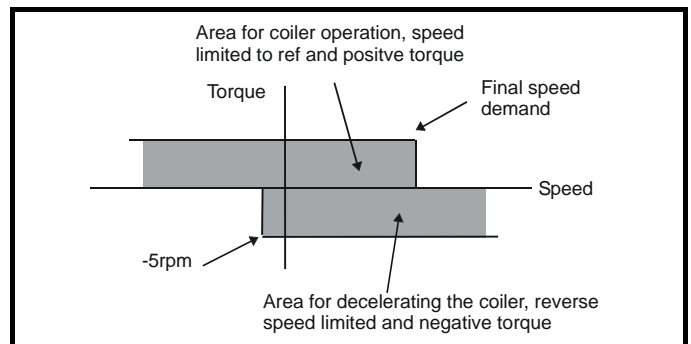
A positive resultant torque will give torque control with a positive speed limit defined by the final speed demand. A negative resultant torque will give torque control with a negative speed limit of -5rpm.

Negative final speed demand:

A negative resultant torque will give torque control with a negative speed limit defined by the final speed demand. A positive resultant torque will give torque control with a positive speed limit of +5rpm.

#### Example of coiler operation:

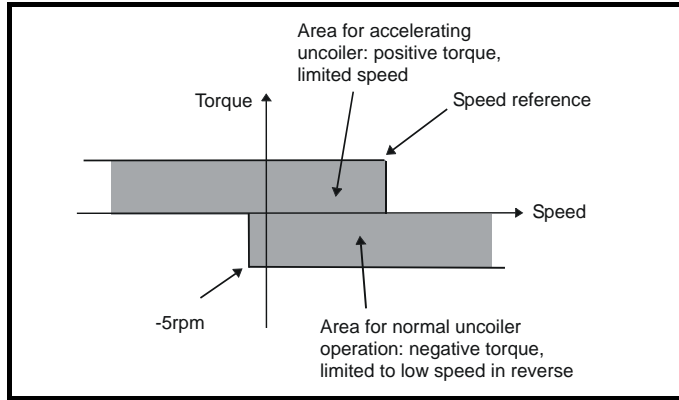
This is an example of a coiler operating in the positive direction. The final speed demand is set to a positive value just above the coiler reference speed. If the resultant torque demand is positive the coiler operates with a limited speed, so that if the material breaks the speed does not exceed a level just above the reference. It is also possible to decelerate the coiler with a negative resultant torque demand. The coiler will decelerate down to -5rpm until a stop is applied. The operating area is shown in the following diagram.



#### Example of uncoiler operation:

This is an example for an uncoiler operating in the positive direction. The final speed demand should be set to a level just above the maximum normal speed. When the resultant torque demand is negative the uncoiler will apply tension and try and rotate at 5rpm in reverse, and so

take up any slack. The uncoiler can operate at any positive speed applying tension. If it is necessary to accelerate the uncoiler a positive resultant torque demand is used. The speed will be limited to the final speed demand. The operating area is the same as that for the coiler and is shown below:



#### 4: Speed control with torque feed-forward

The drive operates under speed control, but a torque value may be added to the output of the speed controller. This can be used to improve the regulation of systems where the speed loop gains need to be low for stability.

### 11.21.5 Stop modes

| 6.01 |     | Stop mode   |           |
|------|-----|---|-----------|
| RW   | Txt |   | US        |
| OL   | ↕   | COASt (0), rP (1), rP.dcl (2), dcl (3), td.dcl (4), diSAbLE (5) | rP (1)    |
| VT   |     | COASt (0), rP (1), no.rP (2)                                    | no.rP (2) |
| SV   |     |   |           |

#### Open-loop

Stopping is in two distinct phases: decelerating to stop, and stopped.

| Stopping Mode                             | Phase 1   | Phase 2   | Comments   |
|---|---|---|--|
| 0: Coast                                  | Inverter disabled   | Drive cannot be re-enabled for 1s                                   | Delay in phase 2 allows rotor flux to decay  |
| 1: Ramp                                   | Ramp down to zero frequency   | Wait for 1s with inverter enabled                                   |  |
| 2: Ramp followed by DC injection          | Ramp down to zero frequency   | Inject DC at level specified by Pr 6.06 for time defined by Pr 6.07 |  |
| 3: DC injection with zero speed detection | Low frequency current injection with detection of low speed before next phase | Inject DC at level specified by Pr 6.06 for time defined by Pr 6.07 | The drive automatically senses low speed and therefore it adjusts the injection time to suit the application. If the injection current level is too small the drive will not sense low speed (normally a minimum of 50-60% is required). |
| 4: Timed DC injection braking stop        | Inject DC at level specified by Pr 6.06 for time specified by Pr 6.07         |   |  |
| 5: Disable                                | Inverter disabled   |   | Allows the drive to be immediately disabled and then re-enabled again immediately if required.   |

Once modes 3 or 4 have begun the drive must go through the ready state before being restarted either by stopping, tripping or being disabled.

If this parameter is set to DiASbLE (5), the disable stopping mode is used when the run command is removed. This mode will allow the drive to be started immediately by re-applying the run command. However, if the drive is disabled by removing the drive enable (i.e. via the Secure Disable input or Pr 6.15 *Drive enable*) then the drive cannot be re-enabled for 1s.

#### Closed-loop vector and Servo

Only one stopping phases exists and the ready state is entered as soon as the single stopping action is complete.

| Stopping Mode | Action                |
|---------------|-----------------------|
| 0: Coast      | Inhibits the inverter |
| 1: Ramp       | Stop with ramp        |
| 2: No ramp    | Stop with no ramp     |

The motor can be stopped with position orientation after stopping. This mode is selected with the position controller mode parameter (Pr 13.10). When this mode is selected Pr 6.01 has no effect.

| 6.06 |     | Injection braking level |  |  |  |  |  |   |       |    |  |    |  |
|------|-----|-------------------------|--|--|--|--|--|---|-------|----|--|----|--|
| RW   | Uni |                         |  |  |  |  |  |   |       | RA |  | US |  |
| OL   | ↕   | 0.0 to 150.0 %          |  |  |  |  |  | ⇒ | 100.0 |    |  |    |  |

Defines the current level used during DC injection braking as a percentage of motor rated current as defined by Pr 5.07.

| 6.07 |     | Injection braking time |  |  |  |  |  |   |     |  |  |    |  |
|------|-----|------------------------|--|--|--|--|--|---|-----|--|--|----|--|
| RW   | Uni |                        |  |  |  |  |  |   |     |  |  | US |  |
| OL   | ↕   | 0.0 to 25.0 s          |  |  |  |  |  | ⇒ | 1.0 |  |  |    |  |

Defines the time of injection braking during phase 1 with stopping modes 3 and 4, and during phase 2 with stopping mode 2 (see Pr 6.01).

| 6.08 |     | Hold zero speed   |  |  |  |  |  |   |         |  |  |    |   |        |  |  |  |   |
|------|-----|-------------------|--|--|--|--|--|---|---------|--|--|----|---|--------|--|--|--|---|
| RW   | Bit |                   |  |  |  |  |  |   |         |  |  | US |   |        |  |  |  |   |
| OL   |     | OFF (0) or On (1) |  |  |  |  |  | ⇒ | OFF (0) |  |  |    |   |        |  |  |  |   |
| VT   | ↕   |                   |  |  |  |  |  |   |         |  |  |    | ⇒ | On (1) |  |  |  |   |
| SV   |     |                   |  |  |  |  |  |   |         |  |  |    |   |        |  |  |  | ⇒ |

When this bit is set the drive remains active even when the run command has been removed and the motor has reached standstill. The drive goes to the 'StoP' state instead of the 'rdy' state.

## 11.21.6 Mains loss modes

| 6.03 |     | Mains loss mode                |  |  |  |  |  |   |         |  |  |    |  |
|------|-----|--------------------------------|--|--|--|--|--|---|---------|--|--|----|--|
| RW   | Txt |                                |  |  |  |  |  |   |         |  |  | US |  |
| ↕    |     | diS (0), StoP (1), ridE.th (2) |  |  |  |  |  | ⇒ | diS (0) |  |  |    |  |

### 0: diS

There is no mains loss detection and the drive operates normally only as long as the DC Bus voltage remains within specification (i.e. >Vuu). Once the voltage falls below Vuu an under-voltage 'UV' trip occurs. This will reset itself if the voltage rises above Vuu Restart, as stated in the table below.

### 1: StoP - Open-loop

The action taken by the drive is the same as for ride through mode, except the ramp down rate is at least as fast as the deceleration ramp setting and the drive will continue to decelerate and stop even if the mains is re-applied. If normal or timed injection braking is selected the drive will use ramp mode to stop on loss of the supply. If ramp stop followed by injection braking is selected, the drive will ramp to a stop and then attempt to apply dc injection. At this point, unless the mains has been restored, the drive is likely to initiate a trip.

### 1: StoP - Closed-loop vector or Servo

The speed reference is set to zero and the ramps are disabled allowing the drive to decelerate the motor to a stop under current limit. If the mains is re-applied whilst the motor is stopping any run signal is ignored until the motor has stopped. If the current limit value is set very low level the drive may trip UV before the motor has stopped.

### 2: ridE.th

The drive detects mains loss when the DC Bus voltage falls below Vml<sub>1</sub>. The drive then enters a mode where a closed-loop controller attempts to hold the DC Bus level at Vml<sub>1</sub>. This causes the motor to decelerate at a rate that increases as the speed falls. If the mains is re-applied it will force the DC Bus voltage above the detection threshold Vml<sub>3</sub> and the drive will continue to operate normally. The output of the mains loss

controller is a current demand that is fed into the current control system and therefore the gain Pr 4.13 and Pr 4.14 must be set up for optimum control. See parameters Pr 4.13 and Pr 4.14 for set-up details.

The following table shows the voltage levels used by drives with each voltage rating.

| Voltage level    | 200V drive             | 400V drive             | 575V drive | 690V drive             |
|------------------|------------------------|------------------------|------------|------------------------|
| Vuu              | 175                    | 330                    |            | 435                    |
| Vml <sub>1</sub> | 205*                   | 410*                   |            | 540*                   |
| Vml <sub>2</sub> | Vml <sub>1</sub> - 10V | Vml <sub>1</sub> - 20V |            | Vml <sub>1</sub> - 25V |
| Vml <sub>3</sub> | Vml <sub>1</sub> + 10V | Vml <sub>1</sub> + 15V |            | Vml <sub>1</sub> + 50V |
| Vuu Restart      | 215                    | 425                    |            | 590                    |

\* Vml<sub>1</sub> is defined by Pr 6.48. The values in the table above are the default values.

| 6.48 |     | Mains loss ride through detection level |  |  |  |  |                 |   |                 |    |  |    |   |
|------|-----|---|--|--|--|--|-----------------|---|-----------------|----|--|----|---|
| RW   | Uni |   |  |  |  |  |                 |   |                 | RA |  | US |   |
| OL   | ↕   | 0 to DC_VOLTAGE_SET_MAX V               |  |  |  |  |                 | ⇒ | 200V drive: 205 |    |  |    |   |
| CL   | ↕   |   |  |  |  |  |                 |   |                 |    |  |    | ⇒ |
|      |     |   |  |  |  |  | 575V drive: 540 |   |                 |    |  |    |   |
|      |     |   |  |  |  |  | 690V drive: 540 |   |                 |    |  |    |   |

The mains loss detection level can be adjusted using this parameter. If the value is reduced below the default value, the default value is used by the drive. If the level is set too high, so that the mains loss detection becomes active under normal operating conditions, the motor will coast to a stop.

| 4.13 |     | Current loop P gain |  |  |  |  |                 |   |                         |  |  |    |   |
|------|-----|---------------------|--|--|--|--|-----------------|---|-------------------------|--|--|----|---|
| RW   | Uni |                     |  |  |  |  |                 |   |                         |  |  | US |   |
| OL   | ↕   | 0 to 30,000         |  |  |  |  |                 | ⇒ | All voltage ratings: 20 |  |  |    |   |
| CL   | ↕   |                     |  |  |  |  |                 |   |                         |  |  |    | ⇒ |
|      |     |                     |  |  |  |  | 400V drive: 150 |   |                         |  |  |    |   |
|      |     |                     |  |  |  |  | 575V drive: 180 |   |                         |  |  |    |   |
|      |     |                     |  |  |  |  | 690V drive: 215 |   |                         |  |  |    |   |

| 4.14 |     | Current loop I gain |  |  |  |  |                   |   |                         |  |  |    |   |
|------|-----|---------------------|--|--|--|--|-------------------|---|-------------------------|--|--|----|---|
| RW   | Uni |                     |  |  |  |  |                   |   |                         |  |  | US |   |
| OL   | ↕   | 0 to 30,000         |  |  |  |  |                   | ⇒ | All voltage ratings: 40 |  |  |    |   |
| CL   | ↕   |                     |  |  |  |  |                   |   |                         |  |  |    | ⇒ |
|      |     |                     |  |  |  |  | 400V drive: 2,000 |   |                         |  |  |    |   |
|      |     |                     |  |  |  |  | 575V drive: 2,400 |   |                         |  |  |    |   |
|      |     |                     |  |  |  |  | 690V drive: 3,000 |   |                         |  |  |    |   |

### Open-loop

These parameters control the proportional and integral gains of the current controller used in the open loop drive. As already mentioned the current controller either provides current limits or closed loop torque control by modifying the drive output frequency. The control loop is also used in its torque mode during mains loss, or when the controlled mode standard ramp is active and the drive is decelerating, to regulate the flow of current into the drive. Although the default settings have been chosen to give suitable gains for less demanding applications it may be necessary for the user to adjust the performance of the controller. The following is a guide to setting the gains for different applications.

### Current limit operation:

The current limits will normally operate with an integral term only, particularly below the point where field weakening begins. The proportional term is inherent in the loop. The integral term must be increased enough to counter the effect of the ramp which is still active even in current limit. For example, if the drive is operating at constant frequency and is overloaded the current limit system will try

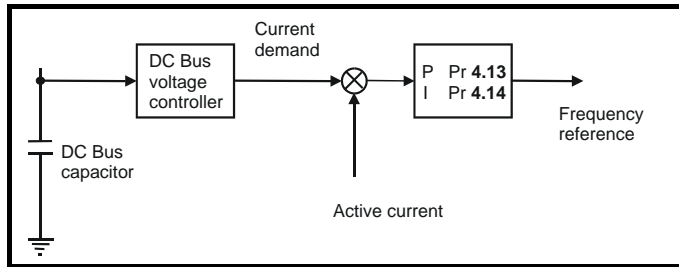
to reduce the output frequency to reduce the load. At the same time the ramp will try to increase the frequency back up to the demand level. If the integral gain is increased too far the first signs of instability will occur when operating around the point where field weakening begins. These oscillations can be reduced by increasing the proportional gain. A system has been included to prevent regulation because of the opposite actions of the ramps and the current limit. This can reduce the actual level that the current limit becomes active by 12.5%. This still allows the current to increase up to the current limit set by the user. However the current limit flag (Pr 10.09) could become active up to 12.5% below the current limit depending on the ramp rate used.

**Torque control:**

Again the controller will normally operate with an integral term only, particularly below the point where field weakening begins. The first signs of instability will appear around base speed, and can be reduced by increasing the proportional gain. The controller can be less stable in torque control mode rather than when it is used for current limiting. This is because load helps to stabilise the controller, and under torque control the drive may operate with light load. Under current limit the drive is often under heavy load unless the current limits are set at a low level.

**Mains loss and controlled standard ramp:**

The DC bus voltage controller becomes active if mains loss detection is enabled and the drive supply is lost or controlled standard ramp is being used and the machine is regenerating. The DC bus controller attempts to hold the DC bus voltage at a fixed level by controlling the flow of current from the drive inverter into its DC bus capacitors. The output of the DC bus controller is a current demand which is fed into the current PI controller as shown in the following diagram.



Although it is not usually necessary the DC bus voltage controller can be adjusted with Pr 5.31. However, it may often be necessary to adjust the current controller gains to obtain the required performance. If the gains are not suitable it is best to set up the drive in torque control first. Set the gains to a value that does not cause instability around the point at which field weakening occurs. Then revert back to open loop speed control in standard ramp mode. To test the controller the supply should be removed whilst the motor is running. It is likely that the gains can be increased further if required because the DC bus voltage controller has a stabilising effect, provided that the drive is not required to operate in torque control mode.

**Closed-loop vector and Servo**

The Kp and Ki gains are used in the voltage based current controller. The default values give satisfactory operation with most motors. However it may be necessary to change the gains to improve the performance. The proportional gain (Pr 4.13) is the most critical value in controlling the performance. Either the value can be set by auto-tuning (see Pr 5.12) or it can be set by the user so that

$$Pr\ 4.13 = K_p = (L / T) \times (I_{fs} / V_{fs}) \times (256 / 5)$$

Where:

T is the sample time of the current controllers. The drive compensates for any change of sample time, and so it should be assumed that the sample time is equivalent to the lowest sample rate of 167µs.

L is the motor inductance. For a servo motor this is half the phase to phase inductance that is normally specified by the manufacturer. For an induction motor this is the per phase transient inductance ( $\sigma L_s$ ). This is the inductance value stored in Pr 5.24 after the autotune test is carried out. If  $\sigma L_s$  cannot be measured it can be calculated from the steady state per-phase equivalent circuit of the motor as follows:

$$\sigma L_s = L_s - \left( \frac{L_m^2}{L_r} \right)$$

$I_{fs}$  is the peak full scale current feedback =  $K_C \times \sqrt{2} / 0.45$ . Where  $K_C$  is defined in Table 11-5 and Table 11-6.  $V_{fs}$  is the maximum DC Bus voltage.

Therefore:

$$Pr\ 4.13 = K_p = (L / 167\mu s) \times (K_C \times \sqrt{2} / 0.45 / V_{fs}) \times (256 / 5) = K \times L \times K_C$$

Where:

$$K = [\sqrt{2} / (0.45 \times V_{fs} \times 167\mu s)] \times (256 / 5)$$

| Drive voltage rating | Vfs   | K    |
|----------------------|-------|------|
| 200V                 | 415V  | 2322 |
| 400V                 | 830V  | 1161 |
| 575V                 | 990V  | 973  |
| 690V                 | 1190V | 951  |

This set-up will give a step response with minimum overshoot after a step change of current reference. The approximate performance of the current controllers will be as given below. The proportional gain can be increased by a factor of 1.5 giving a similar increase in bandwidth, however, this gives a step response with approximately 12.5% overshoot.

| Switching frequency kHz | Current control sample time µs | Gain bandwidth Hz | Phase delay µs |
|-------------------------|--------------------------------|-------------------|----------------|
| 3                       | 167                            | TBA               | 1160           |
| 4                       | 125                            | TBA               | 875            |
| 6                       | 83                             | TBA               | 581            |
| 8                       | 125                            | TBA               | 625            |
| 12                      | 83                             | TBA               | 415            |
| 16                      | 125                            | TBA               | 625            |

The integral gain (Pr 4.14) is less critical and should be set so that

$$Pr\ 4.14 = K_i = K_p \times 256 \times T / \tau_m$$

Where:

$\tau_m$  is the motor time constant (L / R).

R is the per phase stator resistance of the motor (i.e. half the resistance measured between two phases).

Therefore

$$Pr\ 4.14 = K_i = (K \times L \times K_C) \times 256 \times 167\mu s \times R / L = 0.0427 \times K \times R \times K_C$$

The above equation gives a conservative value of integral gain. In some applications where it is necessary for the reference frame used by the drive to dynamically follow the flux very closely (i.e. high speed closed-loop induction motor applications) the integral gain may need to have a significantly higher value.

**11.21.7 Start / stop logic modes**

| 6.04 |        | Start / stop logic select |    |
|------|--------|---------------------------|----|
| RW   | Uni    |                           | US |
| ↕    | 0 to 4 | ⇒                         | 0  |

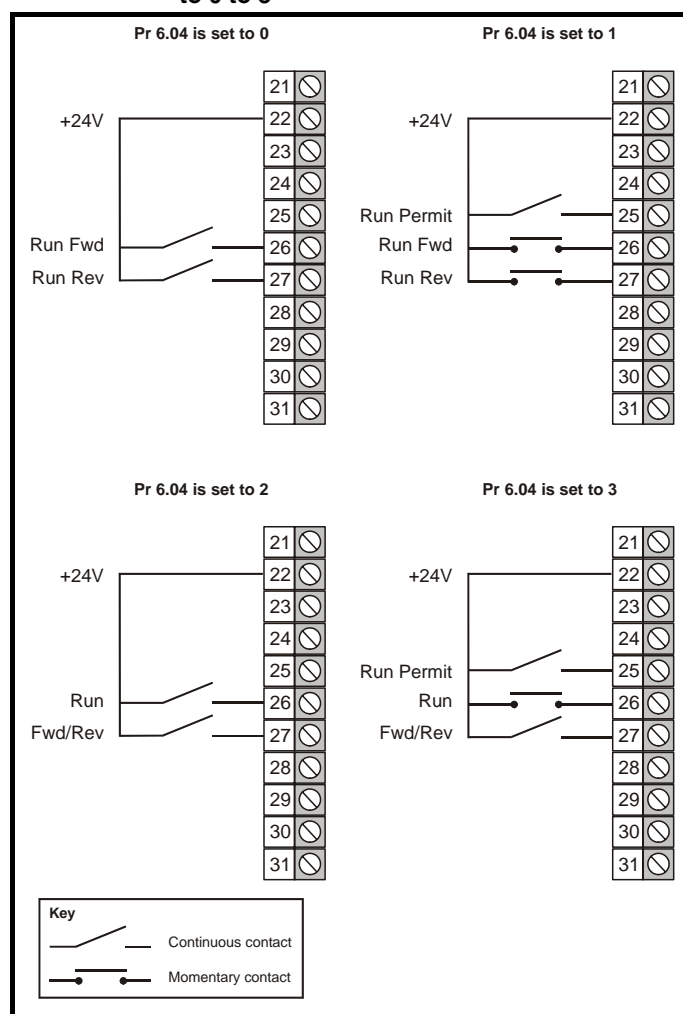
This parameter is provided to allow the user to select several predefined digital input routing macros to control the sequencer. When a value between 0 and 3 is selected the drive processor continuously updates

the destination parameters for digital I/O T25, T26 and T27, and the enable sequencer latching bit (Pr 6.40). When a value of 4 is selected the destination parameters for these digital I/O and Pr 6.40 can be modified by the user.

If Pr 6.04 is changed then a drive reset is required before the function of T25, T26 or T27 will become active.

| Pr 6.04 | T25                     | T26                      | T27                      | Pr 6.40              |
|---------|-------------------------|--------------------------|--------------------------|----------------------|
| 0       | No Function             | Pr 6.30<br>(Run Forward) | Pr 6.32<br>(Run Reverse) | 0<br>(Non Latching)  |
| 1       | Pr 6.39<br>(Run Permit) | Pr 6.30<br>(Run Forward) | Pr 6.32<br>(Run Reverse) | 1<br>(Latching)      |
| 2       | No Function             | Pr 6.34<br>(Run)         | Pr 6.33<br>(Fwd/Rev)     | 0<br>(Non Latching)  |
| 3       | Pr 6.39<br>(Run Permit) | Pr 6.34<br>(Run)         | Pr 6.33<br>(Fwd/Rev)     | 1<br>(Latching)      |
| 4       | User<br>programmable    | User<br>programmable     | User<br>programmable     | User<br>programmable |

**Figure 11-41 Digital input connections when Pr 6.04 is set to 0 to 3**



| 6.40 |                   | Enable sequencer latching |         |
|------|-------------------|---------------------------|---------|
| RW   | Bit               |                           | US      |
| ↕    | OFF (0) or On (1) | ⇒                         | OFF (0) |

This parameter enables sequencer latching. When sequencer latching is used, a digital input must be used as a run permit or not stop input. The digital input should write to Pr 6.39. The run permit or not stop input must

be made active to allow the drive to run. Making the run permit or not stop input inactive resets the latch and stops the drive.

### 11.21.8 Catch a spinning motor

| 6.09 |     | Catch a spinning motor |    |
|------|-----|------------------------|----|
| RW   | Uni |                        | US |
| OL   | ↕   | 0 to 3                 | 0  |
| CL   | ⇒   | 0 to 1                 | 1  |

#### Open-loop

When the drive is enabled with this parameter at zero, the output frequency starts at zero and ramps to the required reference. When the drive is enabled with this parameter at a non-zero value, the drive performs a start-up test to determine the motor speed and then sets the initial output frequency to the synchronous frequency of the motor.

The test is not carried out and the motor frequency starts at zero if one of the following is true.

- The run command is given when the drive is in the stop state
- The drive is first enabled after power-up with Ur\_I voltage mode (Pr 5.14 = Ur\_I).
- The run command is given with Ur\_S voltage mode (Pr 5.14 = Ur\_S).

With default parameters the length of the test is approximately 250ms, however, if the motor has a long rotor time constant (usually large motors) it may be necessary to extend the test time. The drive will do this automatically if the motor parameters including the rated load rpm are set up correctly for the motor.

For the test to operate correctly it is important that the stator resistance (Pr 5.17 or Pr 21.12) is set up correctly. This applies even if fixed boost (Pr 5.14 = Fd) or square law (Pr 5.14 = SrE) voltage mode is being used. The test uses the rated magnetising current of the motor during the test, therefore the rated current (Pr 5.07, Pr 21.07 and Pr 5.10, Pr 21.10) and power factor should be set to values close to those of the motor, although these parameters are not as critical as the stator resistance. For larger motors it may be necessary to increase Pr 5.40 *Spin start boost* from its default value of 1.0 for the drive to successfully detect the motor speed.

It should be noted that a stationary lightly loaded motor with low inertia might move slightly during the test. The direction of the movement is undefined. Restrictions may be placed on the direction of this movement and on the frequencies detected by the drive as follows:

| 06.09 | Function                         |
|-------|----------------------------------|
| 0     | Disabled                         |
| 1     | Detect all frequencies           |
| 2     | Detect positive frequencies only |
| 3     | Detect negative frequencies only |

#### Closed-loop vector and Servo

When the drive is enabled with this bit at zero, the post ramp reference (Pr 2.01) starts at zero and ramps to the required reference. When the drive is enabled with this bit at one, the post ramp reference is set to the motor speed.

When closed-loop vector mode is used without position feedback, and catch a spinning motor is not required, this parameter should be set to zero as this avoids unwanted movement of the motor shaft when zero speed is required. When closed-loop vector mode without position feedback is used with larger motors it may be necessary to increase Pr 5.40 *Spin start boost* from its default value of 1.0 for the drive to successfully detect the motor speed.

| 5.40 |     | Spin start boost |  |  |  |  |  |   |     |  |    |  |
|------|-----|------------------|--|--|--|--|--|---|-----|--|----|--|
| RW   | Uni |                  |  |  |  |  |  |   |     |  | US |  |
| OL   | ↕   | 0.0 to 10.0      |  |  |  |  |  | ⇒ | 1.0 |  |    |  |
| VT   |     |                  |  |  |  |  |  |   |     |  |    |  |

If Pr 6.09 is set to enable the catch a spinning motor function in open-loop mode or closed-loop vector mode without position feedback, (Pr 3.24 = 1 or 3) this parameter defines a scaling function used by the algorithm that detects the speed of the motor. It is likely that for smaller motors the default value of 1.0 is suitable, but for larger motors this parameter may need to be increased. If the value of this parameter is too large the motor may accelerate from standstill when the drive is enabled. If the value of this parameter is too small the drive will detect the motor speed as zero even if the motor is spinning.

### 11.21.9 Position modes

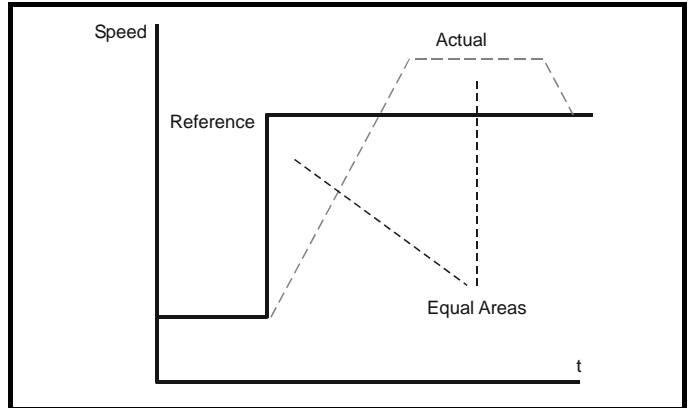
| 13.10 |     | Position controller mode |  |  |  |  |  |   |   |  |    |  |
|-------|-----|--------------------------|--|--|--|--|--|---|---|--|----|--|
| RW    | Uni |                          |  |  |  |  |  |   |   |  | US |  |
| OL    | ↕   | 0 to 2                   |  |  |  |  |  | ⇒ | 0 |  |    |  |
| CL    |     | 0 to 6                   |  |  |  |  |  |   |   |  |    |  |

This parameter is used to set the position controller mode as shown in the table below.

| Parameter value | Mode                                       | Feed forward active |
|-----------------|--|---------------------|
| 0               | Position controller disabled               |                     |
| 1               | Rigid position control                     | ✓                   |
| 2               | Rigid position control                     |                     |
| 3               | Non-rigid position control                 | ✓                   |
| 4               | Non-rigid position control                 |                     |
| 5               | Orientation on stop                        |                     |
| 6               | Orientation on stop and when drive enabled |                     |

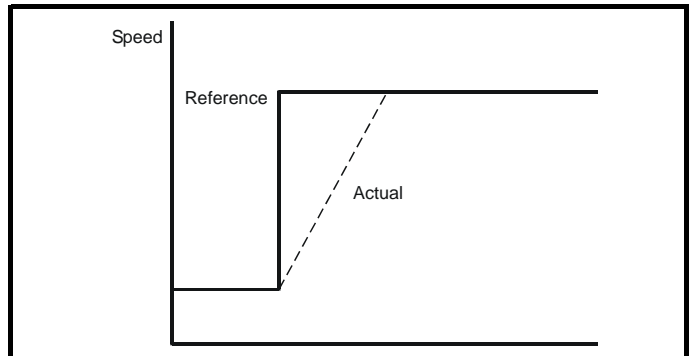
#### Rigid position control

In rigid position control the position error is always accumulated. This means that, if for example, the slave shaft is slowed down due to excessive load, the target position will eventually be recovered by running at a higher speed when the load is removed.



#### Non-rigid position control

In non-rigid position control the position loop is only active when the 'At Speed' condition is met (see Pr 3.06). This allows slippage to occur while the speed error is high.



#### Velocity feed forward

The position controller can generate a velocity feed forwards value from the speed of the reference encoder. The feed-forwards value is passed to menu, and so ramps may be included if required. Because the position controller only has a proportional gain, it is necessary to use

velocity feed-forwards to prevent a constant position error that would be proportional to the speed of the reference position.

If for any reason the user wishes to provide the velocity feed forward from a source other than the reference position, the feed forward system can be made inactive, i.e. Pr **13.10** = 2 or 4. The external feed forward can be provided via Menu 1 from any of the frequency/speed references. However, if the feed forward level is not correct a constant position error will exist.

#### Relative jogging

If relative jogging is enabled the feedback position can be made to move relative the reference position at the speed defined by Pr **13.17**.

#### Orientation

If Pr **13.10** is 5 the drive orientates the motor following a stop command. If hold zero speed is enabled (Pr **6.08** = 1) the drive remains in position control when orientation is complete and hold the orientation position. If hold zero speed is not enabled the drive is disabled when orientation is complete.

If Pr **13.10** is 6 the drive orientates the motor following a stop command and whenever the drive is enabled provided that hold zero speed is enabled (Pr **6.08** = 1). This ensures that the spindle is always in the same position following the drive being enabled.

When orientating from a stop command the drive goes through the following sequence:

1. The motor is decelerated or accelerated to the speed limit programmed in Pr **13.12**, using ramps if these are enabled, in the direction the motor was previously running.
2. When the ramp output reaches the speed set in Pr **13.12**, ramps are disabled and the motor continues to rotate until the position is found to be close to the target position (i.e. within 1/32 of a revolution). At this point the speed demand is set to 0 and the position loop is closed.
3. When the position is within the window defined by Pr **13.14**, the orientation complete indication is given in Pr **13.15**.

The stop mode selected by Pr **6.01** has no effect if orientation is enabled.

## 12 Technical Data

### 12.1 Drive

#### 12.1.1 Power and current ratings (Derating for switching frequency and temperature)

For a full explanation of 'Normal Duty' and 'Heavy Duty' refer to section 2.1 *Ratings* on page 11.

**Table 12-1 Maximum permissible continuous output current @ 40°C (104°F) ambient for wall mounted drives**

| Model   | Normal Duty    |     |   |       |       |      |       |       | Heavy Duty     |      |   |       |      |      |       |       |
|---------|----------------|-----|---|-------|-------|------|-------|-------|----------------|------|---|-------|------|------|-------|-------|
|         | Nominal rating |     | Maximum permissible continuous output current (A) for the following switching frequencies |       |       |      |       |       | Nominal rating |      | Maximum permissible continuous output current (A) for the following switching frequencies |       |      |      |       |       |
|         | kW             | hp  | 3kHz  | 4kHz  | 6kHz  | 8kHz | 12kHz | 16kHz | kW             | hp   | 3kHz  | 4kHz  | 6kHz | 8kHz | 12kHz | 16kHz |
| SP1201  | 1.1            | 1.5 | 5.2   |       |       |      |       |       | 0.75           | 1.0  | 4.3   |       |      |      |       |       |
| SP1202  | 1.5            | 2.0 | 6.8   |       |       |      |       |       | 1.1            | 1.5  | 5.8   |       |      |      |       |       |
| SP1203  | 2.2            | 3.0 | 9.6   |       |       |      |       |       | 1.5            | 2.0  | 7.5   |       |      |      |       |       |
| SP1204  | 3.0            | 3.0 | 11.0  |       |       |      |       |       | 2.2            | 3.0  | 10.6  |       |      |      |       |       |
| SP2201  | 4.0            | 5.0 | 15.5  |       |       |      |       |       | 3.0            | 3.0  | 12.6  |       |      |      |       |       |
| SP2202  | 5.5            | 7.5 | 22.0  |       |       |      |       |       | 4.0            | 5.0  | 17.0  |       |      |      |       |       |
| SP2203  | 7.5            | 10  | 28.0  |       | 27.9  | 24.8 | 21.8  | 5.5   | 7.5            | 25.0 |   | 24.2  | 22.5 | 19.6 | 17.2  |       |
| SP3201  | 11             | 15  | 42.0  |       |       |      |       |       | 7.5            | 10   | 31.0  |       |      |      |       |       |
| SP3202  | 15             | 20  | 54.0  |       |       | 48.5 |       |       | 11             | 15   | 42.0  |       |      |      | 41.3  |       |
| SP4201  | 18.5           | 25  | 68.0  |       |       |      |       |       | 15             | 20   | 56.0  |       |      |      |       |       |
| SP4202  | 22             | 30  | 80.0  |       |       |      |       |       | 18.5           | 25   | 68.0  |       |      |      |       |       |
| SP4203  | 30             | 40  | 104   |       |       |      |       |       | 22             | 30   | 80.0  |       |      |      |       |       |
| SP1401  | 1.1            | 1.5 | 2.8   |       |       |      |       |       | 0.75           | 1.0  | 2.1   |       |      |      |       |       |
| SP1402  | 1.5            | 2.0 | 3.8   |       |       |      |       |       | 1.1            | 2.0  | 3.0   |       |      |      |       |       |
| SP1403  | 2.2            | 3.0 | 5.0   |       |       |      |       |       | 1.5            | 3.0  | 4.2   |       |      |      |       |       |
| SP1404  | 3.0            | 5.0 | 6.9   |       |       |      | 5.9   |       | 2.2            | 3.0  | 5.8   |       |      |      | 5.4   | 4.3   |
| SP1405  | 4.0            | 5.0 | 8.8   |       |       | 7.4  | 5.7   | 3.0   | 5.0            | 7.6  |   |       |      | 5.6  | 4.4   |       |
| SP1406  | 5.5            | 7.5 | 11.0  |       | 10.0  | 7.4  | 5.7   | 4.0   | 5.0            | 9.5  |   | 9.2   | 7.7  | 5.6  | 4.4   |       |
| SP2401  | 7.5            | 10  | 15.3  |       |       |      | 12.7  | 10.1  | 5.5            | 10   | 13.0  |       |      | 12.6 | 9.6   | 7.6   |
| SP2402  | 11             | 15  | 21.0  |       | 19.5  | 16.7 | 12.7  | 10.0  | 7.5            | 10   | 16.5  |       | 14.9 | 12.6 | 9.6   | 7.6   |
| SP2403  | 15             | 20  | 29.0  | 27.2  | 23.2  | 20.0 | 15.0  | 11.8  | 11             | 20   | 25.0  | 23.7  | 19.9 | 16.9 | 12.8  | 10.1  |
| SP2404* | 15             | 20  | 29.0  |       | 26.6  | 22.5 | 16.5  | 12.5  | 15             | 20   | 29.0  | 25.8  | 20.5 | 16.8 | 12.1  | 7.9   |
| SP3401  | 18.5           | 25  | 35.0  |       |       | 34.5 | 26.3  | 21.0  | 15             | 25   | 32.0  |       |      | 28.9 | 22.0  | 17.5  |
| SP3402  | 22             | 30  | 43.0  |       |       | 37.9 | 28.6  | 22.5  | 18.5           | 30   | 40.0  |       | 38.3 | 32.5 | 24.5  | 19.2  |
| SP3403  | 30             | 40  | 56.0  | 53.4  | 44.6  | 37.9 | 28.6  |       | 22             | 30   | 46.0  | 45.9  | 38.3 | 32.5 | 24.4  |       |
| SP4401  | 37             | 50  | 68.0  |       |       | 62.0 |       |       | 30             | 50   | 60.0  |       | 51.9 | 42.4 |       |       |
| SP4402  | 45             | 60  | 83.0  |       | 74.0  | 61.0 |       |       | 37             | 60   | 74.0  | 65.0  | 50.9 | 41.7 |       |       |
| SP4403  | 55             | 75  | 104   |       | 95.1  | 78.8 |       |       | 45             | 75   | 96.0  | 83.6  | 66.6 | 55.2 |       |       |
| SP5401  | 75             | 100 | 138   |       | 118   | 97.1 |       |       | 55             | 100  | 124   | 106.5 | 82.4 | 67.0 |       |       |
| SP5402  | 90             | 125 | 168   | 158   | 129   | 107  |       |       | 75             | 125  | 156   | 137   | 109  | 91.0 |       |       |
| SP6401  | 110            | 150 | 202   |       | 164.1 |      |       | 90    | 150            | 180  | 174.4   | 134.5 |      |      |       |       |
| SP6402  | 132            | 200 | 236   | 210.4 | 157.7 |      |       | 110   | 150            | 210  | 174.8   | 129.7 |      |      |       |       |
| SP3501  | 3.0            | 3.0 | 5.4   |       |       |      |       |       | 2.2            | 2.0  | 4.1   |       |      |      |       |       |
| SP3502  | 4.0            | 5.0 | 6.1   |       |       |      |       |       | 3.0            | 3.0  | 5.4   |       |      |      |       |       |
| SP3503  | 5.5            | 7.5 | 8.4   |       |       |      |       |       | 4.0            | 5.0  | 6.1   |       |      |      |       |       |
| SP3504  | 7.5            | 10  | 11.0  |       |       |      |       |       | 5.5            | 7.5  | 9.5   |       |      |      |       |       |
| SP3505  | 11             | 15  | 16.0  |       |       |      |       |       | 7.5            | 10   | 12.0  |       |      |      |       |       |
| SP3506  | 15             | 20  | 22.0  |       | 21.6  | 18.2 |       | 11    | 15             | 18.0 |   |       | 15.5 |      |       |       |
| SP3507  | 18.5           | 25  | 27.0  | 26.0  | 21.6  | 18.1 |       | 15    | 20             | 22.0 | 18.4  | 15.5  |      |      |       |       |
| SP4601  | 18.5           | 25  | 22.0  |       |       |      |       |       | 15             | 20   | 19.0  |       |      |      |       |       |
| SP4602  | 22             | 30  | 27.0  |       |       |      |       |       | 18.5           | 25   | 22.0  |       |      |      |       |       |
| SP4603  | 30             | 40  | 36.0  |       |       | 33.9 |       |       | 22             | 30   | 27.0  |       |      |      |       |       |
| SP4604  | 37             | 50  | 43.0  |       | 41.3  | 33.7 |       | 30    | 40             | 36.0 |   |       | 33.9 |      |       |       |
| SP4605  | 45             | 60  | 52.0  | 51.9  | 41.2  | 33.7 |       | 37    | 50             | 43.0 |   | 41.3  | 33.7 |      |       |       |
| SP4606  | 55             | 75  | 62.0  | 61.3  | 48.4  | 39.6 |       | 45    | 60             | 52.0 |   | 44.7  | 36.5 |      |       |       |
| SP5601  | 75             | 100 | 84  |       |       |      |       | 55    | 75             | 63   |   |       |      |      |       |       |
| SP5602  | 90             | 125 | 99  |       |       |      |       | 75    | 100            | 85   |   |       |      |      |       |       |
| SP6601  | 110            | 150 | 125   |       |       |      |       | 90    | 125            | 100  |   |       |      |      |       |       |
| SP6602  | 132            | 175 | 144   |       |       |      |       | 110   | 150            | 125  |   |       |      |      |       |       |

**NOTE**

For the definition of ambient temperature, see section 3.9 *Cubicle design and drive ambient temperature* on page 52.

\*See \*SP2404 *Power and current ratings* on page 258.

**Table 12-2 Maximum permissible continuous output current @ 40°C (104°F) ambient for free standing cubicle drives**

| Model  | Normal Duty    |      |   |      |      |      |       | Heavy Duty     |     |   |      |      |      |      |       |       |
|--------|----------------|------|---|------|------|------|-------|----------------|-----|---|------|------|------|------|-------|-------|
|        | Nominal rating |      | Maximum permissible continuous output current (A) for the following switching frequencies |      |      |      |       | Nominal rating |     | Maximum permissible continuous output current (A) for the following switching frequencies |      |      |      |      |       |       |
|        | kW             | hp   | 3kHz  | 4kHz | 6kHz | 8kHz | 12kHz | 16kHz          | kW  | hp  | 3kHz | 4kHz | 6kHz | 8kHz | 12kHz | 16kHz |
| SP8411 | 225            | 300  | 389   | 354  | 271  |      |       | 185            | 280 | 335   | 278  | 205  |      |      |       |       |
| SP8412 | 250            | 400  | 450   | 410  | 313  |      |       | 225            | 300 | 389   | 323  | 238  |      |      |       |       |
| SP8413 | 315            | 450  | 545   | 496  | 379  |      |       | 250            | 400 | 450   | 374  | 275  |      |      |       |       |
| SP8414 | 355            | 500  | 620   | 564  | 432  |      |       | 315            | 450 | 545   | 453  | 333  |      |      |       |       |
| SP9411 | 400            | 600  | 690   | 628  | 480  |      |       | 355            | 500 | 620   | 515  | 379  |      |      |       |       |
| SP9412 | 450            | 700  | 790   | 719  | 550  |      |       | 400            | 600 | 690   | 573  | 422  |      |      |       |       |
| SP9413 | 500            | 800  | 900   | 819  | 626  |      |       | 450            | 700 | 790   | 657  | 483  |      |      |       |       |
| SP9414 | 560            | 900  | 1010  | 919  | 703  |      |       | 500            | 800 | 900   | 748  | 550  |      |      |       |       |
| SP9415 | 675            | 1000 | 1164  | 1060 | 810  |      |       | 560            | 900 | 1010  | 839  | 618  |      |      |       |       |

**NOTE**

For the definition of ambient temperature, see section 3.9 *Cubicle design and drive ambient temperature* on page 52.

**Table 12-3 Maximum permissible continuous output current @ 40°C (104°F) ambient with IP54 insert and standard fan fitted**

| Model   | Normal Duty    |     |   |      |      |      |       | Heavy Duty     |     |   |      |      |      |      |       |       |
|---------|----------------|-----|---|------|------|------|-------|----------------|-----|---|------|------|------|------|-------|-------|
|         | Nominal rating |     | Maximum permissible continuous output current (A) for the following switching frequencies |      |      |      |       | Nominal rating |     | Maximum permissible continuous output current (A) for the following switching frequencies |      |      |      |      |       |       |
|         | kW             | hp  | 3kHz  | 4kHz | 6kHz | 8kHz | 12kHz | 16kHz          | kW  | hp  | 3kHz | 4kHz | 6kHz | 8kHz | 12kHz | 16kHz |
| SP1201  | 1.1            | 1.5 | 5.2   |      |      |      |       | 0.75           | 1.0 | 4.3   |      |      |      |      |       |       |
| SP1202  | 1.5            | 2.0 | 6.8   |      |      |      |       | 1.1            | 1.5 | 5.8   |      |      |      |      |       |       |
| SP1203  | 2.2            | 3.0 | 9.6   |      |      | 9.3  | 8.2   | 7.3            | 1.5 | 2.0   | 7.5  |      |      |      | 7.3   |       |
| SP1204  | 3.0            | 3.0 | 11.0  | 10.6 | 9.7  | 9.0  | 7.7   | 6.6            | 2.2 | 3.0   | 10.6 | 10.5 | 9.7  | 9.0  | 7.7   | 6.6   |
| SP2201  | 4.0            | 5.0 | 15.5  |      |      |      |       | 3.0            | 3.0 | 12.6  |      |      |      |      |       |       |
| SP2202  | 5.5            | 7.5 | 22.0  |      |      | 20.7 | 18.0  | 15.7           | 4.0 | 5.0   | 17.0 |      |      |      | 15.5  |       |
| SP2203  | 7.5            | 10  | 24.5  | 23.7 | 22.0 | 20.5 | 17.9  | 15.6           | 5.5 | 7.5   | 24.2 | 23.4 | 21.8 | 20.3 | 17.7  | 15.5  |
| SP1401  | 1.1            | 1.5 | 2.8   |      |      |      |       | 0.75           | 1.0 | 2.1   |      |      |      |      |       |       |
| SP1402  | 1.5            | 2.0 | 3.8   |      |      |      | 2.9   | 1.1            | 2.0 | 3.0   |      |      |      | 2.9  |       |       |
| SP1403  | 2.2            | 3.0 | 5.0   |      |      | 3.9  | 2.9   | 1.5            | 3.0 | 4.2   |      |      | 3.9  | 2.9  |       |       |
| SP1404  | 3.0            | 5.0 | 6.9   |      | 6.5  | 5.4  | 3.9   | 2.9            | 2.2 | 3.0   | 5.8  |      | 5.4  | 3.9  | 2.9   |       |
| SP1405  | 4.0            | 5.0 | 8.3   | 7.3  | 5.8  | 4.7  | 3.2   | 2.3            | 3.0 | 5.0   | 7.6  | 7.3  | 5.8  | 4.7  | 3.2   | 2.3   |
| SP1406  | 5.5            | 7.5 | 8.3   | 7.3  | 5.8  | 4.7  | 3.2   | 2.3            | 4.0 | 5.0   | 8.2  | 7.3  | 5.8  | 4.7  | 3.2   | 2.3   |
| SP2401  | 7.5            | 10  | 15.3  |      |      | 13.3 | 10.1  | 7.9            | 5.5 | 10  | 13.0 |      |      | 12.6 | 9.4   | 7.3   |
| SP2402  | 11             | 15  | 20.1  | 18.4 | 15.6 | 13.4 | 10.1  | 7.9            | 7.5 | 10  | 16.5 |      | 14.9 | 12.3 | 9.3   | 7.2   |
| SP2403  | 15             | 20  | 21.7  | 19.7 | 16.4 | 13.9 | 10.2  | 7.7            | 11  | 20  | 21.6 | 19.6 | 16.4 | 13.8 | 10.2  | 7.7   |
| SP2404* | 15             | 20  | 20.1  | 17.7 | 14.0 | 11.2 | 7.3   | 4.6            | 15  | 20  | 20.1 | 17.7 | 14.0 | 11.2 | 7.3   | 4.6   |

**NOTE**

For the definition of ambient temperature, see section 3.9 *Cubicle design and drive ambient temperature* on page 52.

**\*SP2404 Power and current ratings**

All Unidrive SP models are dual rated except for the SP2404 which only has a Heavy Duty rating. However, if the current limits in Pr 4.05 to Pr 4.07 are set to a maximum of 110% and the switching frequency is greater than 3kHz, then the drive can be used at a maximum continuous current higher than the Heavy Duty rating. See the Normal Duty ratings in Table 12-1, Table 12-3 and Table 12-4. Normal Duty ratings exist for the SP2404 above 3kHz when the overload is reduced from the default value 165% in open loop or 175% in closed loop, to 110%.

If the current limits in Pr 4.05 to Pr 4.07 are set higher than 110% then the Heavy Duty current ratings are applicable.

**Table 12-4 Maximum permissible continuous output current @ 50°C (122°F) ambient for wall mounted drives**

| Model   | Normal Duty    |     |   |       |       |      |       |       | Heavy Duty     |      |   |       |      |      |       |       |  |
|---------|----------------|-----|---|-------|-------|------|-------|-------|----------------|------|---|-------|------|------|-------|-------|--|
|         | Nominal rating |     | Maximum permissible continuous output current (A) for the following switching frequencies |       |       |      |       |       | Nominal rating |      | Maximum permissible continuous output current (A) for the following switching frequencies |       |      |      |       |       |  |
|         | kW             | hp  | 3kHz  | 4kHz  | 6kHz  | 8kHz | 12kHz | 16kHz | kW             | hp   | 3kHz  | 4kHz  | 6kHz | 8kHz | 12kHz | 16kHz |  |
| SP1201  | 1.1            | 1.5 | 5.2   |       |       |      |       |       | 0.75           | 1.0  | 4.3   |       |      |      |       |       |  |
| SP1202  | 1.5            | 2.0 | 6.8   |       |       |      |       |       | 1.1            | 1.5  | 5.8   |       |      |      |       |       |  |
| SP1203  | 2.2            | 3.0 | 9.6   |       |       |      | 9.0   |       | 1.5            | 2.0  | 7.5   |       |      |      |       |       |  |
| SP1204  | 3.0            | 3.0 | 11.0  |       | 10.9  | 9.5  | 8.3   | 2.2   | 3.0            | 10.6 |   |       | 9.5  | 8.3  |       |       |  |
| SP2201  | 4.0            | 5.0 | 15.5  |       |       |      | 13.5  | 11.5  | 3.0            | 3.0  | 12.6  |       |      |      |       | 11.4  |  |
| SP2202  | 5.5            | 7.5 | 19.7  | 18.9  | 17.3  | 15.9 | 13.5  | 11.5  | 4.0            | 5.0  | 17.0  |       |      | 15.7 | 13.4  | 11.4  |  |
| SP2203  | 7.5            | 10  | 19.5  | 18.6  | 17.2  | 15.8 | 13.4  | 11.5  | 5.5            | 7.5  | 19.2  | 18.4  | 17.0 | 15.7 | 13.3  | 11.4  |  |
| SP3201  | 11             | 15  | 42.0  |       |       |      | 38.2  |       | 7.5            | 10   | 31.0  |       |      |      |       |       |  |
| SP3202  | 15             | 20  | 54.0  |       | 52.8  | 47.0 | 38.2  | 11    | 15             | 42.0 |   |       |      | 37.2 |       |       |  |
| SP4201  | 18.5           | 25  | 68.0  |       |       |      |       |       | 15             | 20   | 56.0  |       |      |      |       |       |  |
| SP4202  | 22             | 30  | 80.0  |       |       |      |       |       | 18.5           | 25   | 68.0  |       |      |      |       |       |  |
| SP4203  | 30             | 40  | 87.4  |       |       |      |       |       | 22             | 30   | 80.0  |       |      |      |       |       |  |
| SP1401  | 1.1            | 1.5 | 2.8   |       |       |      |       |       | 0.75           | 1.0  | 2.1   |       |      |      |       |       |  |
| SP1402  | 1.5            | 2.0 | 3.8   |       |       |      |       |       | 1.1            | 2.0  | 3.0   |       |      |      |       |       |  |
| SP1403  | 2.2            | 3.0 | 5.0   |       |       |      | 3.9   |       | 1.5            | 3.0  | 4.2   |       |      |      | 3.8   |       |  |
| SP1404  | 3.0            | 5.0 | 6.9   |       |       | 5.1  | 3.9   | 2.2   | 3.0            | 5.8  |   |       | 4.8  | 3.7  |       |       |  |
| SP1405  | 4.0            | 5.0 | 8.8   |       | 7.3   | 6.0  | 4.2   | 3.1   | 3.0            | 5.0  | 7.6   |       | 7.2  | 6.0  | 4.2   | 3.1   |  |
| SP1406  | 5.5            | 7.5 | 10.1  | 9.0   | 7.3   | 6.0  | 4.2   | 3.1   | 4.0            | 5.0  | 9.5   | 9.0   | 7.2  | 6.0  | 4.2   | 3.1   |  |
| SP2401  | 7.5            | 10  | 15.3  | 14.2  | 11.8  | 10.0 | 7.3   | 5.5   | 5.5            | 10   | 13.0  |       | 11.7 | 9.9  | 7.3   | 5.5   |  |
| SP2402  | 11             | 15  | 15.7  | 14.2  | 11.8  | 10.0 | 7.3   | 5.5   | 7.5            | 10   | 15.5  | 14.1  | 11.7 | 9.9  | 7.3   | 5.5   |  |
| SP2403  | 15             | 20  | 16.8  | 15.0  | 12.2  | 10.1 | 7.1   |       | 11             | 20   | 16.7  | 15.0  | 12.2 | 10.1 | 7.1   | 5.1   |  |
| SP2404* | 15             | 20  | 22.3  | 19.8  | 15.8  | 12.8 | 8.6   | 5.9   | 15             | 20   | 22.3  | 19.8  | 14.0 | 11.2 | 7.3   | 4.6   |  |
| SP3401  | 18.5           | 25  | 35.0  |       | 33.5  | 28.5 | 21.5  | 16.9  | 15             | 25   | 32.0  |       | 30.7 | 26.1 | 19.7  | 15.4  |  |
| SP3402  | 22             | 30  | 43.0  | 41.5  | 34.2  | 28.7 | 21.0  | 16.0  | 18.5           | 30   | 40.0  |       | 34.1 | 28.4 | 20.7  | 16.0  |  |
| SP3403  | 30             | 40  | 46.0  | 41.5  | 34.2  | 28.7 | 21.0  |       | 22             | 30   | 46.0  | 41.5  | 33.6 | 28.3 | 20.8  |       |  |
| SP4401  | 37             | 50  | 68.0  |       | 66.8  | 54.9 |       |       | 30             | 50   | 60.0  |       | 46.7 | 38.3 |       |       |  |
| SP4402  | 45             | 60  | 83.0  | 81.6  | 66.5  | 52.3 |       |       | 37             | 60   | 68.2  | 58.6  | 46.0 | 37.7 |       |       |  |
| SP4403  | 55             | 75  | 86.5  | 86.2  | 71.3  | 59.3 |       |       | 45             | 75   | 86.5  | 74.7  | 60.1 | 49.8 |       |       |  |
| SP5401  | 75             | 100 | 138   |       | 105.9 | 87.4 |       |       | 55             | 100  | 112.7   | 96.4  | 74.5 | 59.9 |       |       |  |
| SP5402  | 90             | 125 | 141   | 140   | 112   | 92   |       |       | 75             | 125  | 140   | 123   | 99.0 | 82.0 |       |       |  |
| SP6401  | 110            | 150 | 191.5   | 190.1 | 147.6 |      |       | 90    | 150            | 180  | 157.9   | 121.5 |      |      |       |       |  |
| SP6402  | 132            | 200 | 198.4   | 180.6 | 138.1 |      |       | 110   | 150            | 190  | 157.9   | 116.2 |      |      |       |       |  |
| SP3501  | 3.0            | 3.0 | 5.4   |       |       |      |       |       | 2.2            | 2.0  | 4.1   |       |      |      |       |       |  |
| SP3502  | 4.0            | 5.0 | 6.1   |       |       |      |       |       | 3.0            | 3.0  | 5.4   |       |      |      |       |       |  |
| SP3503  | 5.5            | 7.5 | 8.4   |       |       |      |       |       | 4.0            | 5.0  | 6.1   |       |      |      |       |       |  |
| SP3504  | 7.5            | 10  | 11.0  |       |       |      |       |       | 5.5            | 7.5  | 9.5   |       |      |      |       |       |  |
| SP3505  | 11             | 15  | 16.0  |       |       | 14.7 |       |       |                | 7.5  | 10  | 12.0  |      |      |       |       |  |
| SP3506  | 15             | 20  | 22.0  |       | 17.8  | 14.7 |       |       | 11             | 15   | 18.0  |       | 16.8 | 13.9 |       |       |  |
| SP3507  | 18.5           | 25  | 24.6  | 22.0  | 17.8  | 14.7 |       |       | 15             | 20   | 22.0  | 20.4  | 16.7 | 13.9 |       |       |  |
| SP4601  | 18.5           | 25  | 22.0  |       |       |      |       |       | 15             | 20   | 19.0  |       |      |      |       |       |  |
| SP4602  | 22             | 30  | 27.0  |       |       | 24.7 |       |       |                | 18.5 | 25  | 22.0  |      |      |       |       |  |
| SP4603  | 30             | 40  | 36.0  |       | 30.7  | 24.7 |       |       | 22             | 30   | 27.0  |       |      |      |       |       |  |
| SP4604  | 37             | 50  | 43.0  | 39.6  | 30.7  | 24.7 |       |       | 30             | 40   | 36.0  |       | 30.7 | 24.7 |       |       |  |
| SP4605  | 45             | 60  | 45.6  | 39.5  | 30.7  | 24.7 |       |       | 37             | 50   | 43.0  | 39.6  | 30.7 | 24.7 |       |       |  |
| SP4606  | 55             | 75  | 51.9  | 44.9  | 34.7  | 27.7 |       |       | 45             | 60   | 51.9  | 44.9  | 34.7 | 27.7 |       |       |  |
| SP5601  | 75             | 100 |   |       |       |      |       |       | 55             | 75   |   |       |      |      |       |       |  |
| SP5602  | 90             | 125 |   |       |       |      |       |       | 75             | 100  |   |       |      |      |       |       |  |
| SP6601  | 110            | 150 |   |       |       |      |       |       | 90             | 125  |   |       |      |      |       |       |  |
| SP6602  | 132            | 175 |   |       |       |      |       |       | 110            | 150  |   |       |      |      |       |       |  |

**NOTE**

For the definition of ambient temperature, see section 3.9 *Cubicle design and drive ambient temperature* on page 52.

\*See \*SP2404 *Power and current ratings* on page 258.

**Table 12-5 Maximum permissible continuous output current @ 50°C (122°F) ambient for free standing cubicle mounted drives**

| Model  | Normal Duty    |      |   |      |      |      |       | Heavy Duty     |     |   |      |      |      |      |       |       |
|--------|----------------|------|---|------|------|------|-------|----------------|-----|---|------|------|------|------|-------|-------|
|        | Nominal rating |      | Maximum permissible continuous output current (A) for the following switching frequencies |      |      |      |       | Nominal rating |     | Maximum permissible continuous output current (A) for the following switching frequencies |      |      |      |      |       |       |
|        | kW             | hp   | 3kHz  | 4kHz | 6kHz | 8kHz | 12kHz | 16kHz          | kW  | hp  | 3kHz | 4kHz | 6kHz | 8kHz | 12kHz | 16kHz |
| SP8411 | 225            | 300  | 327   | 298  | 228  |      |       |                | 185 | 280   | 303  | 252  | 185  |      |       |       |
| SP8412 | 250            | 400  | 378   | 344  | 263  |      |       |                | 225 | 300   | 352  | 292  | 215  |      |       |       |
| SP8413 | 315            | 450  | 458   | 417  | 319  |      |       |                | 250 | 400   | 407  | 338  | 249  |      |       |       |
| SP8414 | 355            | 500  | 521   | 474  | 363  |      |       |                | 315 | 450   | 493  | 410  | 302  |      |       |       |
| SP9411 | 400            | 600  | 580   | 528  | 404  |      |       |                | 355 | 500   | 561  | 466  | 343  |      |       |       |
| SP9412 | 450            | 700  | 664   | 605  | 462  |      |       |                | 400 | 600   | 624  | 519  | 382  |      |       |       |
| SP9413 | 500            | 800  | 757   | 689  | 527  |      |       |                | 450 | 700   | 715  | 594  | 437  |      |       |       |
| SP9414 | 560            | 900  | 849   | 773  | 591  |      |       |                | 500 | 800   | 814  | 677  | 498  |      |       |       |
| SP9415 | 675            | 1000 | 979   | 897  | 681  |      |       |                | 560 | 900   | 914  | 759  | 559  |      |       |       |

**NOTE**

For the definition of ambient temperature, see section 3.9 *Cubicle design and drive ambient temperature* on page 52.

## 12.1.2 Power dissipation

Table 12-6 Losses @ 40°C (104°F) ambient for wall mounted drives

| Model  | Drive losses (W) taking into consideration any current derating for the given conditions |     |      |      |      |      |       |       |                |     |      |      |      |      |       |       |
|--------|--|-----|------|------|------|------|-------|-------|----------------|-----|------|------|------|------|-------|-------|
|        | Normal Duty  |     |      |      |      |      |       |       | Heavy Duty     |     |      |      |      |      |       |       |
|        | Nominal rating   |     | 3kHz | 4kHz | 6kHz | 8kHz | 12kHz | 16kHz | Nominal rating |     | 3kHz | 4kHz | 6kHz | 8kHz | 12kHz | 16kHz |
|        | kW   | hp  |      |      |      |      |       |       | kW             | hp  |      |      |      |      |       |       |
| SP1201 | 1.1  | 1.5 | 33   | 35   | 38   | 42   | 49    | 56    | 0.75           | 1   | 27   | 29   | 32   | 35   | 41    | 47    |
| SP1202 | 1.5  | 2.0 | 45   | 47   | 51   | 56   | 64    | 73    | 1.1            | 1.5 | 38   | 40   | 43   | 47   | 55    | 62    |
| SP1203 | 2.2  | 3.0 | 67   | 70   | 76   | 81   | 92    | 104   | 1.5            | 2.0 | 51   | 53   | 58   | 62   | 71    | 81    |
| SP1204 | 3.0  | 3.0 | 78   | 82   | 89   | 97   | 113   | 129   | 2.2            | 3.0 | 75   | 78   | 86   | 94   | 109   | 124   |
| SP2201 | 4.0  | 5.0 | 155  | 161  | 173  | 186  | 210   | 235   | 3.0            | 3.0 | 133  | 139  | 150  | 160  | 182   | 203   |
| SP2202 | 5.5  | 7.5 | 210  | 218  | 234  | 250  | 282   | 314   | 4.0            | 5.0 | 170  | 176  | 190  | 203  | 229   | 256   |
| SP2203 | 7.5  | 10  | 272  | 282  | 302  | 320  |       | 315   | 5.5            | 7.5 | 245  | 254  | 263  | 261  | 259   | 258   |
| SP3201 | 11   | 15  | 331  | 347  | 380  | 412  | 477   |       | 7.5            | 10  | 260  | 272  | 297  | 321  | 370   |       |
| SP3202 | 15   | 20  | 431  | 451  | 492  | 532  | 551   |       | 11             | 15  | 349  | 365  | 398  | 430  | 486   |       |
| SP4201 | 18.5   | 25  | 517  | 541  | 589  | 637  |       |       | 15             | 20  | 428  | 448  | 488  | 528  |       |       |
| SP4202 | 22   | 30  | 611  | 639  | 694  | 750  |       |       | 18.5           | 25  | 517  | 541  | 589  | 637  |       |       |
| SP4203 | 30   | 40  | 810  | 845  | 916  | 987  |       |       | 22             | 30  | 611  | 639  | 694  | 750  |       |       |
| SP1401 | 1.1  | 1.5 | 26   | 29   | 37   | 45   | 61    | 76    | 0.75           | 1.0 | 20   | 24   | 30   | 37   | 51    | 64    |
| SP1402 | 1.5  | 2.0 | 34   | 38   | 48   | 57   | 76    | 95    | 1.1            | 2.0 | 27   | 31   | 39   | 48   | 64    | 80    |
| SP1403 | 2.2  | 3.0 | 44   | 50   | 61   | 72   | 95    | 117   | 1.5            | 3.0 | 37   | 42   | 52   | 62   | 82    | 102   |
| SP1404 | 3.0  | 5.0 | 62   | 69   | 83   | 97   | 126   | 134   | 2.2            | 3.0 | 52   | 58   | 70   | 83   | 101   | 104   |
| SP1405 | 4.0  | 5.0 | 83   | 94   | 117  | 139  | 156   | 157   | 3.0            | 5.0 | 72   | 82   | 101  | 121  | 123   | 125   |
| SP1406 | 5.5  | 7.5 | 106  | 120  | 147  | 158  | 156   | 157   | 4.0            | 5.0 | 91   | 103  | 123  |      |       | 125   |
| SP2401 | 7.5  | 10  | 186  | 202  | 234  | 266  | 283   | 282   | 5.5            | 10  | 164  | 178  | 206  | 229  |       | 231   |
| SP2402 | 11   | 15  | 248  | 269  | 291  | 286  | 283   | 281   | 7.5            | 10  | 201  | 218  | 230  | 229  |       | 231   |
| SP2403 | 15   | 20  | 313  | 320  |      |      | 315   | 316   | 11             | 20  | 272  | 282  | 279  | 278  | 279   | 282   |
| SP2404 | 15   | 20  | 311  | 343  | 376  |      |       |       | 15             | 20  | 311  | 308  | 301  | 299  | 302   | 284   |
| SP3401 | 18.5   | 25  | 364  | 392  | 449  | 499  | 477   | 465   | 15             | 25  | 337  | 363  | 415  | 424  | 408   | 401   |
| SP3402 | 22   | 30  | 437  | 471  | 540  | 538  | 514   | 501   | 18.5           | 30  | 411  | 443  | 485  | 469  | 452   | 444   |
| SP3403 | 30   | 40  | 567  | 580  | 552  | 533  | 510   |       | 22             | 30  | 474  | 509  | 485  | 469  | 452   |       |
| SP4401 | 37   | 50  | 714  | 781  | 914  | 956  |       |       | 30             | 50  | 629  | 689  | 704  | 674  |       |       |
| SP4402 | 45   | 60  | 882  | 961  | 995  | 941  |       |       | 37             | 60  | 780  | 745  | 690  | 663  |       |       |
| SP4403 | 55   | 75  | 1070 | 1158 | 1217 | 1144 |       |       | 45             | 75  | 976  | 920  | 854  | 821  |       |       |
| SP5401 | 75   | 100 | 1471 | 1618 | 1640 | 1560 |       |       | 55             | 100 | 1311 | 1236 | 1150 | 1112 |       |       |
| SP5402 | 90   | 125 | 1830 | 1881 | 1781 | 1717 |       |       | 75             | 125 | 1681 | 1600 | 1508 | 1464 |       |       |
| SP6401 | 110  | 150 | 2058 | 2259 | 2153 |      |       |       | 90             | 150 | 1817 | 1935 | 1772 |      |       |       |
| SP6402 | 132  | 200 | 2477 | 2455 | 2255 |      |       |       | 110            | 150 | 2192 | 2042 | 1888 |      |       |       |
| SP3501 | 3.0  | 3.0 | 127  | 141  | 168  | 196  |       |       | 2.2            | 2.0 | 112  | 124  | 148  | 172  |       |       |
| SP3502 | 4.0  | 5.0 | 135  | 150  | 180  | 209  |       |       | 3.0            | 3.0 | 127  | 141  | 168  | 196  |       |       |
| SP3503 | 5.5  | 7.5 | 163  | 181  | 218  | 254  |       |       | 4.0            | 5.0 | 135  | 150  | 180  | 209  |       |       |
| SP3504 | 7.5  | 10  | 197  | 219  | 263  | 306  |       |       | 5.5            | 7.5 | 178  | 198  | 237  | 276  |       |       |
| SP3505 | 11   | 15  | 267  | 296  | 354  | 412  |       |       | 7.5            | 10  | 212  | 235  | 281  | 328  |       |       |
| SP3506 | 15   | 20  | 362  | 399  | 475  | 471  |       |       | 11             | 15  | 300  | 332  | 396  | 405  |       |       |
| SP3507 | 18.5   | 25  | 448  | 486  | 477  | 471  |       |       | 15             | 20  | 365  | 403  | 406  | 405  |       |       |
| SP4601 | 18.5   | 25  | 409  | 470  | 590  | 711  |       |       | 15             | 20  | 360  | 413  | 519  | 625  |       |       |
| SP4602 | 22   | 30  | 496  | 568  | 712  | 857  |       |       | 18.5           | 25  | 409  | 470  | 590  | 711  |       |       |
| SP4603 | 30   | 40  | 660  | 754  | 941  | 1063 |       |       | 22             | 30  | 496  | 568  | 712  | 857  |       |       |
| SP4604 | 37   | 50  | 798  | 908  | 1083 | 1058 |       |       | 30             | 40  | 660  | 754  | 941  | 1063 |       |       |
| SP4605 | 45   | 60  | 985  | 1115 | 1080 | 1058 |       |       | 37             | 50  | 798  | 908  | 1083 | 1058 |       |       |
| SP4606 | 55   | 75  | 1060 | 1179 | 1130 | 1105 |       |       | 45             | 60  | 873  | 987  | 1042 | 1023 |       |       |
| SP5601 | 75   | 100 |      |      |      |      |       |       | 55             | 75  |      |      |      |      |       |       |
| SP5602 | 90   | 125 |      |      |      |      |       |       | 75             | 100 |      |      |      |      |       |       |
| SP6601 | 110  | 150 |      |      |      |      |       |       | 90             | 125 |      |      |      |      |       |       |
| SP6602 | 132  | 175 |      |      |      |      |       |       | 110            | 150 |      |      |      |      |       |       |

**NOTE**

For the definition of ambient temperature, see section 3.9 *Cubicle design and drive ambient temperature* on page 52.

**Table 12-7 Losses @ 40°C (104°F) ambient for free standing cubicle drives**

| Model  | Drive losses (W) taking into consideration any current derating for the given conditions |      |       |       |       |      |       |            |                |       |       |       |      |      |       |       |
|--------|--|------|-------|-------|-------|------|-------|------------|----------------|-------|-------|-------|------|------|-------|-------|
|        | Normal Duty  |      |       |       |       |      |       | Heavy Duty |                |       |       |       |      |      |       |       |
|        | Nominal rating   |      | 3kHz  | 4kHz  | 6kHz  | 8kHz | 12kHz | 16kHz      | Nominal rating |       | 3kHz  | 4kHz  | 6kHz | 8kHz | 12kHz | 16kHz |
|        | kW   | hp   |       |       |       |      |       |            | kW             | hp    |       |       |      |      |       |       |
| SP8411 | 225  | 300  | 4592  | 5061  | 5769  |      |       | 185        | 280            | 3968  | 4355  | 4919  |      |      |       |       |
| SP8412 | 250  | 400  | 5102  | 5624  | 6410  |      |       | 225        | 300            | 4826  | 5297  | 5983  |      |      |       |       |
| SP8413 | 315  | 450  | 6429  | 7086  | 8077  |      |       | 250        | 400            | 5363  | 5885  | 6648  |      |      |       |       |
| SP8414 | 355  | 500  | 7245  | 7986  | 9103  |      |       | 315        | 450            | 6757  | 7416  | 8376  |      |      |       |       |
| SP9411 | 400  | 600  | 8163  | 8998  | 10256 |      |       | 355        | 500            | 7615  | 8357  | 9440  |      |      |       |       |
| SP9412 | 450  | 700  | 9184  | 10123 | 1538  |      |       | 400        | 600            | 8580  | 9417  | 10637 |      |      |       |       |
| SP9413 | 500  | 800  | 10204 | 11247 | 12821 |      |       | 450        | 700            | 9653  | 10594 | 11966 |      |      |       |       |
| SP9414 | 560  | 900  | 11429 | 12597 | 14359 |      |       | 500        | 800            | 10725 | 11771 | 13296 |      |      |       |       |
| SP9415 | 675  | 1000 | 13776 | 15184 | 17308 |      |       | 560        | 900            | 12012 | 13183 | 14891 |      |      |       |       |

**Table 12-8 Losses @ 40°C (104°F) ambient with IP54 insert and standard fan fitted**

| Model  | Drive losses (W) taking into consideration any current derating for the given conditions |     |      |      |      |      |       |            |                |     |      |      |      |      |       |       |     |
|--------|--|-----|------|------|------|------|-------|------------|----------------|-----|------|------|------|------|-------|-------|-----|
|        | Normal Duty  |     |      |      |      |      |       | Heavy Duty |                |     |      |      |      |      |       |       |     |
|        | Nominal rating   |     | 3kHz | 4kHz | 6kHz | 8kHz | 12kHz | 16kHz      | Nominal rating |     | 3kHz | 4kHz | 6kHz | 8kHz | 12kHz | 16kHz |     |
|        | kW   | hp  |      |      |      |      |       |            | kW             | hp  |      |      |      |      |       |       |     |
| SP1201 | 1.1  | 1.5 | 33   | 35   | 38   | 42   | 49    | 56         | 0.75           | 1.0 | 27   | 29   | 32   | 35   | 41    | 47    |     |
| SP1202 | 1.5  | 2.0 | 45   | 47   | 51   | 56   | 64    | 73         | 1.1            | 1.5 | 38   | 40   | 43   | 47   | 55    | 62    |     |
| SP1203 | 2.2  | 3.0 | 67   | 70   | 76   | 78   |       |            | 1.5            | 2.0 | 51   | 53   | 58   | 62   | 71    | 78    |     |
| SP1204 | 3.0  | 3.0 | 78   |      |      |      |       |            |                | 2.2 | 3.0  | 75   | 78   |      |       |       |     |
| SP2201 | 4.0  | 5.0 | 155  | 161  | 173  | 186  | 210   | 235        | 3.0            | 3.0 | 133  | 139  | 150  | 160  | 182   | 203   |     |
| SP2202 | 5.5  | 7.5 | 210  | 218  | 234  | 237  |       |            | 4.0            | 5.0 | 170  | 176  | 190  | 203  | 229   | 237   |     |
| SP2203 | 7.5  | 10  | 237  |      |      |      |       |            |                | 5.5 | 7.5  | 237  |      |      |       |       |     |
| SP1401 | 1.1  | 1.5 | 26   | 29   | 37   | 45   | 61    | 76         | 0.75           | 1.0 | 20   | 24   | 30   | 37   | 51    | 64    |     |
| SP1402 | 1.5  | 2.0 | 34   | 38   | 48   | 57   | 76    | 78         | 1.1            | 2.0 | 27   | 31   | 39   | 48   | 64    | 78    |     |
| SP1403 | 2.2  | 3.0 | 44   | 50   | 61   | 72   | 78    |            | 1.5            | 3.0 | 37   | 42   | 52   | 62   | 78    |       |     |
| SP1404 | 3.0  | 5.0 | 62   | 69   | 78   |      |       |            | 2.2            | 3.0 | 52   | 58   | 70   | 78   |       |       |     |
| SP1405 | 4.0  | 5.0 | 78   |      |      |      |       |            |                | 3.0 | 5.0  | 72   | 78   |      |       |       |     |
| SP1406 | 5.5  | 7.5 | 78   |      |      |      |       |            |                | 4.0 | 5.0  | 78   |      |      |       |       |     |
| SP2401 | 7.5  | 10  | 186  | 202  | 234  | 237  |       |            | 5.5            | 10  | 164  | 178  | 206  | 229  | 226   |       |     |
| SP2402 | 11   | 15  | 237  |      |      |      |       |            |                | 7.5 | 10   | 201  | 218  | 230  | 224   |       |     |
| SP2403 | 15   | 20  | 237  |      |      |      |       |            |                | 11  | 20   | 237  |      |      |       |       |     |
| SP2404 | 15   | 20  | 225  |      |      |      |       | 220        |                | 15  | 20   | 225  |      |      |       |       | 220 |

**Table 12-9 Losses @ 50°C (122°F) ambient for wall mounted drives**

| Model  | Drive losses (W) taking into consideration any current derating for the given conditions |     |      |      |      |      |       |       |                |     |      |      |      |      |       |       |  |
|--------|--|-----|------|------|------|------|-------|-------|----------------|-----|------|------|------|------|-------|-------|--|
|        | Normal Duty  |     |      |      |      |      |       |       | Heavy Duty     |     |      |      |      |      |       |       |  |
|        | Nominal rating   |     | 3kHz | 4kHz | 6kHz | 8kHz | 12kHz | 16kHz | Nominal rating |     | 3kHz | 4kHz | 6kHz | 8kHz | 12kHz | 16kHz |  |
|        | kW   | hp  |      |      |      |      |       |       | kW             | hp  |      |      |      |      |       |       |  |
| SP1201 | 1.1  | 1.5 | 33   | 35   | 38   | 42   | 49    | 56    | 0.75           | 1   | 27   | 29   | 32   | 35   | 41    | 47    |  |
| SP1202 | 1.5  | 2.0 | 45   | 47   | 51   | 56   | 64    | 73    | 1.1            | 1.5 | 38   | 40   | 43   | 47   | 55    | 62    |  |
| SP1203 | 2.2  | 3.0 | 67   | 70   | 76   | 81   | 92    | 97    | 1.5            | 2.0 | 51   | 53   | 58   | 62   | 71    | 81    |  |
| SP1204 | 3.0  | 3.0 | 78   | 82   | 89   | 97   |       | 2.2   | 3.0            | 75  | 78   | 86   | 94   | 97   |       |       |  |
| SP2201 | 4.0  | 5.0 | 155  | 161  | 173  | 186  | 190   |       | 3.0            | 3.0 | 133  | 139  | 150  | 160  | 182   | 190   |  |
| SP2202 | 5.5  | 7.5 | 190  |      |      |      |       | 4.0   | 5.0            | 170 | 176  | 190  |      |      |       |       |  |
| SP2203 | 7.5  | 10  | 190  |      |      |      |       | 5.5   | 7.5            | 190 |      |      |      |      |       |       |  |
| SP3201 | 11   | 15  | 331  | 347  | 380  | 412  | 436   |       | 7.5            | 10  | 260  | 272  | 297  | 321  | 370   |       |  |
| SP3202 | 15   | 20  | 431  | 451  | 480  | 463  | 439   |       | 11             | 15  | 349  | 365  | 398  | 430  | 439   |       |  |
| SP4201 | 18.5   | 25  | 517  | 541  | 589  | 637  |       |       | 15             | 20  | 428  | 448  | 488  | 528  |       |       |  |
| SP4202 | 22   | 30  | 611  | 639  | 694  | 750  |       |       | 18.5           | 25  | 517  | 541  | 589  | 637  |       |       |  |
| SP4203 | 30   | 40  | 671  | 701  | 761  | 821  |       |       | 22             | 30  | 611  | 639  | 694  | 750  |       |       |  |
| SP1401 | 1.1  | 1.5 | 26   | 29   | 37   | 45   | 61    | 76    | 0.75           | 1.0 | 20   | 24   | 30   | 37   | 51    | 64    |  |
| SP1402 | 1.5  | 2.0 | 34   | 38   | 48   | 57   | 76    | 95    | 1.1            | 2.0 | 27   | 31   | 39   | 48   | 64    | 80    |  |
| SP1403 | 2.2  | 3.0 | 44   | 50   | 61   | 72   | 95    | 97    | 1.5            | 3.0 | 37   | 42   | 52   | 62   | 82    | 95    |  |
| SP1404 | 3.0  | 5.0 | 62   | 69   | 83   | 97   |       | 2.2   | 3.0            | 52  | 58   | 70   | 83   | 92   |       |       |  |
| SP1405 | 4.0  | 5.0 | 83   | 94   | 97   |      |       | 3.0   | 5.0            | 72  | 82   | 97   |      |      |       |       |  |
| SP1406 | 5.5  | 7.5 | 97   |      |      |      |       | 4.0   | 5.0            | 91  | 97   |      |      |      |       |       |  |
| SP2401 | 7.5  | 10  | 186  | 190  |      |      |       | 5.5   | 10             | 164 | 178  | 190  |      |      |       |       |  |
| SP2402 | 11   | 15  | 190  |      |      |      |       | 7.5   | 10             | 190 |      |      |      |      |       |       |  |
| SP2403 | 15   | 20  | 190  |      |      |      | 11    | 20    | 190            |     |      |      |      |      |       |       |  |
| SP2404 | 15   | 20  | 245  |      |      |      | 15    | 20    | 245            |     |      |      |      |      | 229   |       |  |
| SP3401 | 18.5   | 25  | 364  | 392  | 430  | 417  | 399   | 389   | 15             | 25  | 337  | 363  | 399  | 387  | 373   | 364   |  |
| SP3402 | 22   | 30  | 437  | 455  | 435  | 418  | 399   | 388   | 18.5           | 30  | 411  | 443  | 435  | 417  | 396   | 388   |  |
| SP3403 | 30   | 40  | 474  | 459  | 429  | 415  | 397   |       | 22             | 30  | 474  | 459  | 429  | 415  | 397   |       |  |
| SP4401 | 37   | 50  | 714  | 781  | 898  | 852  |       |       | 30             | 50  | 629  | 689  | 638  | 617  |       |       |  |
| SP4402 | 45   | 60  | 882  | 944  | 894  | 814  |       |       | 37             | 60  | 716  | 673  | 629  | 607  |       |       |  |
| SP4403 | 55   | 75  | 877  | 949  | 912  | 875  |       |       | 45             | 75  | 876  | 820  | 775  | 750  |       |       |  |
| SP5401 | 75   | 100 | 1471 | 1616 | 1462 | 1411 |       |       | 55             | 100 | 1186 | 1118 | 1047 | 1009 |       |       |  |
| SP5402 | 90   | 125 | 1500 | 1644 | 1543 | 1480 |       |       | 75             | 125 | 1500 | 1434 | 1366 | 1333 |       |       |  |
| SP6401 | 110  | 150 | 1942 | 2118 | 1939 |      |       |       | 90             | 150 | 1817 | 1747 | 1610 |      |       |       |  |
| SP6402 | 132  | 200 | 2068 | 2108 | 1997 |      |       |       | 110            | 150 | 1979 | 1851 | 1715 |      |       |       |  |
| SP3501 | 3.0  | 3.0 | 127  | 141  | 168  | 196  |       |       | 2.2            | 2.0 | 112  | 124  | 148  | 172  |       |       |  |
| SP3502 | 4.0  | 5.0 | 135  | 150  | 180  | 209  |       |       | 3.0            | 3.0 | 127  | 141  | 168  | 196  |       |       |  |
| SP3503 | 5.5  | 7.5 | 163  | 181  | 218  | 254  |       |       | 4.0            | 5.0 | 135  | 150  | 180  | 209  |       |       |  |
| SP3504 | 7.5  | 10  | 197  | 219  | 263  | 306  |       |       | 5.5            | 7.5 | 178  | 198  | 237  | 276  |       |       |  |
| SP3505 | 11   | 15  | 267  | 296  | 354  | 383  |       |       | 7.5            | 10  | 212  | 235  | 281  | 328  |       |       |  |
| SP3506 | 15   | 20  | 362  | 399  | 390  | 384  |       |       | 11             | 15  | 300  | 332  | 372  | 369  |       |       |  |
| SP3507 | 18.5   | 25  | 405  | 399  | 390  | 384  |       |       | 15             | 20  | 365  | 374  | 369  |      |       |       |  |
| SP4601 | 18.5   | 25  | 409  | 470  | 590  | 711  |       |       | 15             | 20  | 360  | 413  | 519  | 625  |       |       |  |
| SP4602 | 22   | 30  | 496  | 568  | 712  | 789  |       |       | 18.5           | 25  | 409  | 470  | 590  | 711  |       |       |  |
| SP4603 | 30   | 40  | 660  | 754  | 805  | 789  |       |       | 22             | 30  | 496  | 568  | 712  | 789  |       |       |  |
| SP4604 | 37   | 50  | 798  | 831  | 805  | 789  |       |       | 30             | 40  | 660  | 754  | 805  | 789  |       |       |  |
| SP4605 | 45   | 60  | 850  | 831  | 805  | 789  |       |       | 37             | 50  | 798  | 831  | 805  | 789  |       |       |  |
| SP4606 | 55   | 75  | 871  | 848  | 816  | 797  |       |       | 45             | 60  | 871  | 848  | 816  | 797  |       |       |  |
| SP5601 | 75   | 100 |      |      |      |      |       |       | 55             | 75  |      |      |      |      |       |       |  |
| SP5602 | 90   | 125 |      |      |      |      |       |       | 75             | 100 |      |      |      |      |       |       |  |
| SP6601 | 110  | 150 |      |      |      |      |       |       | 90             | 125 |      |      |      |      |       |       |  |
| SP6602 | 132  | 175 |      |      |      |      |       |       | 110            | 150 |      |      |      |      |       |       |  |

**Table 12-10 Losses @ 50°C (122°F) ambient for free standing cubicle drives**

| Model  | Drive losses (W) taking into consideration any current derating for the given conditions |      |      |      |      |      |       |            |                |    |      |      |      |      |       |       |
|--------|--|------|------|------|------|------|-------|------------|----------------|----|------|------|------|------|-------|-------|
|        | Normal Duty  |      |      |      |      |      |       | Heavy Duty |                |    |      |      |      |      |       |       |
|        | Nominal rating   |      | 3kHz | 4kHz | 6kHz | 8kHz | 12kHz | 16kHz      | Nominal rating |    | 3kHz | 4kHz | 6kHz | 8kHz | 12kHz | 16kHz |
|        | kW   | hp   |      |      |      |      |       |            | kW             | hp |      |      |      |      |       |       |
| SP8411 | 225  | 300  |      |      |      |      |       | 185        | 280            |    |      |      |      |      |       |       |
| SP8412 | 250  | 400  |      |      |      |      |       | 225        | 300            |    |      |      |      |      |       |       |
| SP8413 | 315  | 450  |      |      |      |      |       | 250        | 400            |    |      |      |      |      |       |       |
| SP8414 | 355  | 500  |      |      |      |      |       | 315        | 450            |    |      |      |      |      |       |       |
| SP9411 | 400  | 600  |      |      |      |      |       | 355        | 500            |    |      |      |      |      |       |       |
| SP9412 | 450  | 700  |      |      |      |      |       | 400        | 600            |    |      |      |      |      |       |       |
| SP9413 | 500  | 800  |      |      |      |      |       | 450        | 700            |    |      |      |      |      |       |       |
| SP9414 | 560  | 900  |      |      |      |      |       | 500        | 800            |    |      |      |      |      |       |       |
| SP9415 | 675  | 1000 |      |      |      |      |       | 560        | 900            |    |      |      |      |      |       |       |

**Table 12-11 Power losses from the front of the drive when through-panel mounted**

| Frame size | Power loss |
|------------|------------|
| 1          | ≤50W       |
| 2          | ≤75W       |
| 3          | ≤100W      |
| 4          | ≤204W      |
| 5          | ≤347W      |
| 6          | ≤480W      |

### 12.1.3 Supply requirements

Voltage:

- SPX20X 200V to 240V ±10%
- SPX40X 380V to 480V ±10%
- SPX50X 500V to 575V ±10%
- SPX60X 500V to 690V ±10%

Number of phases: 3

Maximum supply imbalance: 2% negative phase sequence (equivalent to 3% voltage imbalance between phases).

Frequency range: 48 to 65 Hz

For UL compliance only, the maximum supply symmetrical fault current must be limited to 100kA

#### Unidrive SP size 6 heatsink fan supply requirements

- Nominal voltage: 24V
- Minimum voltage: 23.5V
- Maximum voltage: 27V
- Current drawn: 3.3A
- Recommended power supply: 24V, 100W, 4.5A
- Recommended fuse: 4A fast blow ( $I^2t$  less than 20A<sup>2</sup>s)

### 12.1.4 Line reactors

Input line reactors reduce the risk of damage to the drive resulting from poor phase balance or severe disturbances on the supply network.

Where line reactors are to be used, reactance values of approximately 2% are recommended. Higher values may be used if necessary, but may result in a loss of drive output (reduced torque at high speed) because of the voltage drop.

For all drive ratings, 2% line reactors permit drives to be used with a supply unbalance of up to 3.5% negative phase sequence (equivalent to 5% voltage imbalance between phases).

Severe disturbances may be caused by the following factors, for example:

- Power factor correction equipment connected close to the drive.
- Large DC drives having no or inadequate line reactors connected to the supply.
- Direct-on-line started motor(s) connected to the supply such that when any of these motors are started, the voltage dip exceeds 20%

Such disturbances may cause excessive peak currents to flow in the input power circuit of the drive. This may cause nuisance tripping, or in extreme cases, failure of the drive.

Drives of low power rating may also be susceptible to disturbance when connected to supplies with a high rated capacity.

Line reactors are particularly recommended for use with the following drive models when one of the above factors exists, or when the supply capacity exceeds 175kVA:

- SP1201 SP1202 SP1203 SP1204
- SP1401 SP1402 SP1403 SP1404

Model sizes SP1405 to SP4606 have an internal DC choke and SP5401 to SP6602 have internal AC line chokes, so they do not require AC line reactors except for cases of excessive phase unbalance or extreme supply conditions.

When required each drive must have its own reactor(s). Three individual reactors or a single three-phase reactor should be used.

#### Reactor current ratings

The current rating of the line reactors should be as follows:

Continuous current rating:

- Not less than the continuous input current rating of the drive

Repetitive peak current rating:

- Not less than twice the continuous input current rating of the drive

### 12.1.5 Motor requirements

No. of phases: 3

Maximum voltage:

- Unidrive SP (200V): 240V
- Unidrive SP (400V): 480V
- Unidrive SP (575V): 575V
- Unidrive SP (690V): 690V

### 12.1.6 Temperature, humidity and cooling method

Ambient temperature operating range:

- 0°C to 50°C (32°F to 122°F).

Output current derating must be applied at ambient temperatures >40°C (104°F).

Minimum temperature at power-up:

- 15°C (5°F), the supply must be cycled when the drive has warmed up to 0°C (32°F).

Cooling method: Forced convection

Maximum humidity: 95% non-condensing at 40°C (104°F)

### 12.1.7 Storage

-40°C (-40°F) to +50°C (122°F) for long term storage, or to +70°C (158°F) for short term storage.

### 12.1.8 Altitude

Altitude range: 0 to 3,000m (9,900 ft), subject to the following conditions:

1,000m to 3,000m (3,300 ft to 9,900 ft) above sea level: de-rate the maximum output current from the specified figure by 1% per 100m (330 ft) above 1,000m (3,300 ft)

For example at 3,000m (9,900ft) the output current of the drive would have to be de-rated by 20%.

### 12.1.9 IP Rating (Ingress Protection)

The Unidrive SP is rated to IP20 pollution degree 2 (dry, non-conductive contamination only) (NEMA 1). However, it is possible to configure the drive to achieve IP54 rating (NEMA 12) at the rear of the heatsink for through-panel mounting (some current derating is required).

In order to achieve the high IP rating at the rear of the heatsink with Unidrive SP size 1 and 2, it is necessary to seal a heatsink vent by fitting the IP54 insert as shown in Figure 3-45 and Figure 3-46 on page 54. For increased fan life time in a dirty environment the heatsink fan must be replaced with an IP54 rated fan on size 1 to 4. Sizes 5 and 6 are fitted with IP54 heatsink fans as standard. Contact the supplier of the drive for details. Fitting of the IP54 insert and/or IP54 rated fan on sizes 1 and 2 requires output current derating to be applied, see section 12.1.1 *Power and current ratings (Derating for switching frequency and temperature)* on page 257 for further details.

The IP rating of a product is a measure of protection against ingress and contact to foreign bodies and water. It is stated as IP XX, where the two digits (XX) indicate the degree of protection provided as shown in Table 12-12.

**Table 12-12 IP Rating degrees of protection**

| First digit   | Second digit  |
|---|---|
| Protection against contact and ingress of foreign bodies  | Protection against ingress of water   |
| 0 No protection   | 0 No protection   |
| 1 Protection against large foreign bodies $\phi > 50\text{mm}$ (large area contact with the hand) | 1 -   |
| 2 Protection against medium size foreign bodies $\phi > 12\text{mm}$ (finger)                     | 2 -   |
| 3 Protection against small foreign bodies $\phi > 2.5\text{mm}$ (tools, wires)                    | 3 Protection against spraywater (up to 60° from the vertical)                   |
| 4 Protection against granular foreign bodies $\phi > 1\text{mm}$ (tools, wires)                   | 4 Protection against splashwater (from all directions)                          |
| 5 Protection against dust deposit, complete protection against accidental contact.                | 5 Protection against heavy splash water (from all directions, at high pressure) |
| 6 Protection against dust ingress, complete protection against accidental contact.                | 6 Protection against deckwater (e.g. in heavy seas)                             |
| 7 -   | 7 Protection against immersion  |
| 8 -   | 8 Protection against submersion   |

**Table 12-13 NEMA enclosure ratings**

| NEMA rating | Description   |
|-------------|---|
| Type 1      | Enclosures are intended for indoor use, primarily to provide a degree of protection against contact with the enclosed equipment or locations where unusual service conditions do not exist. |
| Type 12     | Enclosures are intended for indoor use, primarily to provide a degree of protection against dust, falling dirt and dripping non-corrosive liquids.  |

### 12.1.10 Corrosive gasses

Concentrations of corrosive gasses must not exceed the levels given in:

- Table A2 of EN 50178
- Class 3C1 of IEC 60721-3-3

This corresponds to the levels typical of urban areas with industrial activities and/or heavy traffic, but not in the immediate neighbourhood of industrial sources with chemical emissions.

### 12.1.11 Vibration

#### Bump Test

Testing in each of three mutually perpendicular axes in turn.

Referenced standard: IEC 60068-2-29: Test Eb:

Severity: 18g, 6ms, half sine

No. of Bumps: 600 (100 in each direction of each axis)

#### Random Vibration Test

Testing in each of three mutually perpendicular axes in turn.

Referenced standard: IEC 60068-2-64: Test Fh:

Severity: 1.0 m<sup>2</sup>/s<sup>3</sup> (0.01 g<sup>2</sup>/Hz) ASD from 5 - 20 Hz  
-3 dB/octave from 20 to 200 Hz

Duration: 30 minutes in each of 3 mutually perpendicular axes.

#### Sinusoidal Vibration Test

Testing in each of three mutually perpendicular axes in turn.

Referenced standard: IEC 60068-2-6: Test Fc:

Frequency range: 2 - 500 Hz

Severity: 3.5 mm peak displacement from 2 to 9 Hz  
10 m/s<sup>2</sup> peak acceleration from 9 to 200 Hz  
15 m/s<sup>2</sup> peak acceleration from 200 to 500 Hz

Sweep rate: 1 octave/minute

Duration: 15 minutes in each of 3 mutually perpendicular axes.

### 12.1.12 Starts per hour

By electronic control: unlimited

By interrupting the AC supply:  $\leq 20$  (equally spaced)

### 12.1.13 Start up time

This is the time taken from the moment of applying power to the drive, to the drive being ready to run the motor:

Sizes 1 to 6: 4s

### 12.1.14 Output frequency / speed range

Open-loop frequency range: 0 to 3,000Hz

Closed-loop speed range: 0 to 600Hz

Closed-loop frequency range: 0 to 1,250Hz

### 12.1.15 Accuracy and resolution

#### Speed:

The absolute frequency and speed accuracy depends on the accuracy of the crystal used with the drive microprocessor. The accuracy of the crystal is 100ppm, and so the absolute frequency/speed accuracy is 100ppm (0.01%) of the reference, when a preset speed is used. If an analogue input is used the absolute accuracy is further limited by the absolute accuracy of the analogue input.

The following data applies to the drive only; it does not include the performance of the source of the control signals.

Open loop resolution:

Preset frequency reference: 0.1Hz  
Precision frequency reference: 0.001Hz

Closed loop resolution

Preset speed reference: 0.1rpm  
Precision speed reference: 0.001rpm  
Analogue input 1: 16bit plus sign  
Analogue input 2: 10bit plus sign

**Current:**

The resolution of the current feedback is 10bit plus sign. The typical accuracy of the current feedback is 2%.

### 12.1.16 Acoustic noise

The heatsink fan generates the majority of the acoustic noise produced by the drive. The heatsink fan on Unidrive SP size 1 and 2 is a dual speed fan and on size 3 to 6 it is a variable speed fan. The drive controls the speed at which the fan runs based on the temperature of the heatsink and the drive's thermal model system. On Unidrive SP size 4 to 6 the minimum speed of the heatsink fan is 0 rpm. The Unidrive SP size 3 to 6 is also fitted with a single speed fan to ventilate the capacitor bank.

Table 12-14 gives the acoustic noise produced by the drive for the heatsink fan running at the maximum and minimum speeds.

**Table 12-14 Acoustic noise data for wall mounted drives**

| Size | < Date code M38 |               | ≥ Date code M38 |               |
|------|-----------------|---------------|-----------------|---------------|
|      | Max speed dBA   | Min speed dBA | Max speed dBA   | Min speed dBA |
| 1    | 48              | 41            | 48              | 28            |
| 2    | 54              | 45            | 54              | 35            |
| 3    | 56              | 43            | 56              | 43            |
| 4    |                 |               |                 |               |
| 5    |                 |               |                 |               |
| 6    |                 |               |                 |               |

**Table 12-15 Acoustic noise data for free standing cubicle drives**

| Size | < Date code M38 |               | ≥ Date code M38 |               |
|------|-----------------|---------------|-----------------|---------------|
|      | Max speed dBA   | Min speed dBA | Max speed dBA   | Min speed dBA |
| 8    |                 |               | 70*             | 57*           |
| 9    |                 |               |                 |               |

\*These figures are worst case as they include some low level background noise due to the location of the measurement.

### 12.1.17 Overall dimensions

H Height including surface mounting brackets  
W Width  
D Projection forward of panel when surface mounted  
F Projection forward of panel when through-panel mounted  
R Projection rear of panel when through-panel mounted

**Table 12-16 Overall wall mounted drive dimensions**

| Size | Dimension            |                     |                     |                    |                     |
|------|----------------------|---------------------|---------------------|--------------------|---------------------|
|      | H                    | W                   | D                   | F                  | R                   |
| 1    | 386mm<br>(15.197in)  | 100mm<br>(3.937in)  | 219mm<br>(8.622in)  | 139mm<br>(5.472in) | ≤80mm<br>(3.150in)  |
| 2    | 389mm<br>(15.315in)  | 155mm<br>(6.102in)  |                     |                    |                     |
| 3    |                      | 250mm<br>(9.843in)  | 260mm<br>(10.236in) | 140mm<br>(5.512in) | ≤120mm<br>(4.724in) |
| 4    | 547mm<br>(21.528in)  | 310mm<br>(12.205in) | 298mm<br>(11.732in) | 200mm<br>(7.874in) | ≤98mm<br>(3.858in)  |
| 5    | 858mm<br>(33.752in)  |                     |                     |                    |                     |
| 6    | 1169mm<br>(46.016in) |                     |                     |                    |                     |

**Table 12-17 Overall free standing cubicle mounted drive dimensions**

| Size | Dimension            |                     |                     |   |   |
|------|----------------------|---------------------|---------------------|---|---|
|      | H                    | W                   | D                   | F | R |
| 8    | 2180mm<br>(85.827in) | 400mm<br>(15.748in) | 600mm<br>(23.622in) |   |   |
| 9    | 2180mm<br>(85.827in) | 800mm<br>(31.496in) | 600mm<br>(23.622in) |   |   |

### 12.1.18 Weights

**Table 12-18 Overall wall mounted drive weights**

| Size | Model                                 | kg  | lb    |
|------|---------------------------------------|-----|-------|
| 1    | SP1201 to SP1204,<br>SP1401 to SP1404 | 5   | 11.0  |
|      | SP1405 and SP1406                     | 5.8 | 12.8  |
| 2    | All                                   | 7   | 15.4  |
| 3    | All                                   | 15  | 33.1  |
| 4    | All                                   | 30  | 66.1  |
| 5    | All                                   | 55  | 121.3 |
| 6    | All                                   | 75  | 165.3 |

**Table 12-19 Overall free standing cubicle drive weights**

| Size | Model | kg  | lb   |
|------|-------|-----|------|
| 8    | All   | 266 | 586  |
| 9    | All   | 532 | 1173 |

### 12.1.19 Input current, fuse and cable size ratings

The input current is affected by the supply voltage and impedance.

#### Typical input current

The values of typical input current are given to aid calculations for power flow and power loss.

The values of typical input current are stated for a balanced supply.

#### Maximum continuous input current

The values of maximum continuous input current are given to aid the selection of cables and fuses. These values are stated for the worst case condition with the unusual combination of stiff supply with bad balance. The value stated for the maximum continuous input current would only be seen in one of the input phases. The current in the other two phases would be significantly lower.

The values of maximum input current are stated for a supply with a 2% negative phase-sequence imbalance and rated at the maximum supply fault current given in Table 12-20.

**Table 12-20 Supply fault current used to calculate maximum input currents**

| Model | Symmetrical fault level (kA) |
|-------|------------------------------|
| All   | 100                          |

**Table 12-21 Size 1 to 3 input current, fuse and cable size ratings**

| Model  | Typical input current<br>A | Maximum continuous input current<br>A | European cable size EN60204 |                          |                           | USA cable size UL508C                          |              |               |
|--------|----------------------------|---------------------------------------|-----------------------------|--------------------------|---------------------------|--|--------------|---------------|
|        |                            |                                       | Fuse rating IEC gG<br>A     | Input<br>mm <sup>2</sup> | Output<br>mm <sup>2</sup> | Fuse rating Class CC <30A<br>Class J >30A<br>A | Input<br>AWG | Output<br>AWG |
|        |                            |                                       | SP1201                      | 7.1                      | 9.5                       | 10   | 1.5          | 1.0           |
| SP1202 | 9.2                        | 11.3                                  | 12                          | 1.5                      | 1.0                       | 15   | 14           | 16            |
| SP1203 | 12.5                       | 16.4                                  | 20                          | 4.0                      | 1.0                       | 20   | 12           | 14            |
| SP1204 | 15.4                       | 19.1                                  | 20                          | 4.0                      | 1.5                       | 20   | 12           | 14            |
| SP2201 | 13.4                       | 18.1                                  | 20                          | 4.0                      | 2.5                       | 20   | 12           | 14            |
| SP2202 | 18.2                       | 22.6                                  | 25                          | 4.0                      | 4.0                       | 25   | 10           | 10            |
| SP2203 | 24.2                       | 28.3                                  | 32                          | 6.0                      | 6.0                       | 30   | 8            | 8             |
| SP3201 | 35.4                       | 43.1                                  | 50                          | 16                       | 16                        | 45   | 6            | 6             |
| SP3202 | 46.8                       | 54.3                                  | 63                          | 25                       | 25                        | 60   | 4            | 4             |
| SP1401 | 4.1                        | 4.8                                   | 8                           | 1.0                      | 1.0                       | 8  | 16           | 22            |
| SP1402 | 5.1                        | 5.8                                   | 8                           | 1.0                      | 1.0                       | 8  | 16           | 20            |
| SP1403 | 6.8                        | 7.4                                   | 8                           | 1.0                      | 1.0                       | 10   | 16           | 18            |
| SP1404 | 9.3                        | 10.6                                  | 12                          | 1.5                      | 1.0                       | 15   | 14           | 16            |
| SP1405 | 10                         | 11                                    | 12                          | 1.5                      | 1.0                       | 15   | 14           | 14            |
| SP1406 | 12.6                       | 13.4                                  | 16                          | 2.5                      | 1.5                       | 15   | 14           | 14            |
| SP2401 | 15.7                       | 17                                    | 20                          | 4.0                      | 2.5                       | 20   | 12           | 14            |
| SP2402 | 20.2                       | 21.4                                  | 25                          | 4.0                      | 4.0                       | 25   | 10           | 10            |
| SP2403 | 26.6                       | 27.6                                  | 32                          | 6.0                      | 6.0                       | 30   | 8            | 8             |
| SP2404 | 26.6                       | 27.6                                  | 32                          | 6.0                      | 6.0                       | 30   | 8            | 8             |
| SP3401 | 34.2                       | 36.2                                  | 40                          | 10                       | 10                        | 40   | 6            | 6             |
| SP3402 | 40.2                       | 42.7                                  | 50                          | 16                       | 16                        | 45   | 6            | 6             |
| SP3403 | 51.3                       | 53.5                                  | 63                          | 25                       | 25                        | 60   | 4            | 4             |
| SP3501 | 5.0                        | 6.7                                   | 8                           | 1.0                      | 1.0                       | 10   | 16           | 18            |
| SP3502 | 6.0                        | 8.2                                   | 10                          | 1.0                      | 1.0                       | 10   | 16           | 16            |
| SP3503 | 7.8                        | 11.1                                  | 12                          | 1.5                      | 1.0                       | 15   | 14           | 14            |
| SP3504 | 9.9                        | 14.4                                  | 16                          | 2.5                      | 1.5                       | 15   | 14           | 14            |
| SP3505 | 13.8                       | 18.1                                  | 20                          | 4.0                      | 2.5                       | 20   | 12           | 14            |
| SP3506 | 18.2                       | 22.2                                  | 25                          | 4.0                      | 4.0                       | 25   | 10           | 10            |
| SP3507 | 22.2                       | 26.0                                  | 32                          | 6.0                      | 6.0                       | 30   | 8.0          | 8.0           |

**Table 12-22 Size 4, 5 and 6 input current, fuse and cable size ratings**

| Model  | Typical input current | Maximum input current | Fuse option 1 |                           | Fuse option 2 semiconductor fuse in series with HRC fuse or breaker |                             | Cable size |         |                 |         |
|--------|-----------------------|-----------------------|---------------|---------------------------|---|-----------------------------|------------|---------|-----------------|---------|
|        |                       |                       | IEC class gR  | North America: Ferraz HSJ | HRC IEC class gG UL class J   | Semi-conductor IEC class aR | Input      |         | Output          |         |
|        |                       |                       | A             | A                         | A   | A                           | A          | A       | mm <sup>2</sup> | AWG     |
| SP4201 | 62.1                  | 68.9                  | 100           | 90                        | 90  | 160                         | 25         | 3       | 25              | 3       |
| SP4202 | 72.1                  | 78.1                  | 100           | 100                       | 100   | 160                         | 35         | 3       | 35              | 3       |
| SP4203 | 94.5                  | 99.9                  | 125           | 125                       | 125   | 200                         | 70         | 1       | 70              | 1       |
| SP4401 | 61.2                  | 62.3                  | 80            | 80                        | 80  | 160                         | 25         | 3       | 25              | 3       |
| SP4402 | 76.3                  | 79.6                  | 110           | 110                       | 100   | 200                         | 35         | 2       | 35              | 2       |
| SP4403 | 94.1                  | 97.2                  | 125           | 125                       | 125   | 200                         | 70         | 1       | 70              | 1       |
| SP5401 | 126                   | 131                   | 200           | 175                       | 160   | 200                         | 95         | 2/0     | 95              | 2/0     |
| SP5402 | 152                   | 156                   | 250           | 225                       | 200   | 250                         | 120        | 4/0     | 120             | 4/0     |
| SP6401 | 206                   | 215                   | 250           | 250                       | 250   | 315                         | 2 x 70     | 2 x 2/0 | 2 x 70          | 2 x 2/0 |
| SP6402 | 247                   | 258                   | 315           | 300                       | 300   | 350                         | 2 x 120    | 2 x 4/0 | 2 x 120         | 2 x 4/0 |
| SP8411 | 377                   | 418                   |               |                           | 500   | 400                         | 2 x 120    | 2 x 410 | 2 x 120         | 2 x 410 |
| SP8412 | 432                   | 479                   |               |                           | 500   | 800                         | 2 x 120    | 2 x 500 | 2 x 120         | 2 x 500 |
| SP8413 | 535                   | 593                   |               |                           | 600   | 800                         | 2 x 185    | 3 x 400 | 2 x 185         | 3 x 400 |
| SP8414 | 631                   | 700                   |               |                           | 700   | 800                         | 2 x 240    | 4 x 350 | 2 x 240         | 4 x 350 |
| SP4601 | 23                    | 26.5                  | 63            | 60                        | 32  | 125                         | 4          | 10      | 4               | 10      |
| SP4602 | 26.1                  | 28.8                  | 63            | 60                        | 40  | 125                         | 6          | 8       | 6               | 8       |
| SP4603 | 32.9                  | 35.1                  | 63            | 60                        | 50  | 125                         | 10         | 8       | 10              | 8       |
| SP4604 | 39                    | 41                    | 63            | 60                        | 50  | 125                         | 16         | 6       | 16              | 6       |
| SP4605 | 46.2                  | 47.9                  | 63            | 60                        | 63  | 125                         | 16         | 6       | 16              | 6       |
| SP4606 | 55.2                  | 56.9                  | 80            | 60                        | 63  | 125                         | 25         | 4       | 25              | 4       |
| SP5601 | 75.5                  | 82.6                  | 125           | 100                       | 90  | 160                         | 35         | 2       | 35              | 2       |
| SP5602 | 89.1                  | 94.8                  | 125           | 100                       | 125   | 160                         | 50         | 1       | 50              | 1       |
| SP6601 | 128                   | 139                   | 160           | 175                       | 150   | 315                         | 2 x 50     | 2 x 1   | 2 x 50          | 2 x 1   |
| SP6602 | 144                   | 155                   | 160           | 175                       | 160   | 315                         | 2 x 50     | 2 x 1   | 2 x 50          | 2 x 1   |

The Semiconductor IEC class aR fuses for size 8 and 9 drives must be fitted within the cubicle, see Figure 3-20 on page 36. These parts may be bought from Control Techniques, see Table 12-23.

**Table 12-23 Size 8 and 9 fuses**

| Fuse IEC aR | Part No.  |
|-------------|-----------|
| 800A        | 4300-0800 |
| 400A        | 4300-0400 |

**Inrush current**

The Unidrive SP will have an inrush current during power-up, the peak inrush is limited to the value shown below:

|                    |            |
|--------------------|------------|
| SP120X             | 18 A peak  |
| SP140X             | 35 A peak  |
| SP220X             | 12 A peak  |
| SP240X             | 24 A peak  |
| SP320X             | 8 A peak   |
| SP340X             | 14 A peak  |
| SP350X             | 18 A peak  |
| SP420X             | 73 A peak  |
| SP4401             | 37 A peak  |
| SP4402 and SP4403: | 73 A peak  |
| SP460X             | 35 A peak  |
| SP540X             | 110 A peak |
| SP560X             | 70 A peak  |

**NOTE**

The inrush current for all Unidrive SP after a brown-out can be larger than the power-up inrush.

**12.1.20 Maximum motor cable lengths**

**Table 12-24 Maximum motor cable lengths (200V drives)**

| 200V Nominal AC supply voltage |   |              |              |             |       |       |              |              |              |             |             |             |              |              |             |             |             |        |
|--------------------------------|---|--------------|--------------|-------------|-------|-------|--------------|--------------|--------------|-------------|-------------|-------------|--------------|--------------|-------------|-------------|-------------|--------|
| Model                          | Maximum permissible motor cable length for each of the following frequencies  |              |              |             |       |       |              |              |              |             |             |             |              |              |             |             |             |        |
|                                | 3kHz  | 4kHz         | 6kHz         | 8kHz        | 12kHz | 16kHz |              |              |              |             |             |             |              |              |             |             |             |        |
| SP1201                         | 65m (210ft)   |              |              |             |       |       |              |              |              |             |             |             |              |              |             |             |             |        |
| SP1202                         | 100m (330ft)  |              |              |             |       |       |              |              |              |             |             |             |              |              |             |             |             |        |
| SP1203                         | 130m (425ft)  |              |              |             |       |       |              |              |              |             |             |             |              |              |             |             |             |        |
| SP1204                         | <table border="1"> <tr> <td rowspan="5">200m (660ft)</td> <td rowspan="5">150m (490ft)</td> <td rowspan="5">100m (330ft)</td> <td rowspan="5">75m (245ft)</td> <td rowspan="5">50m (165ft)</td> <td rowspan="5">37m (120ft)</td> </tr> </table> |              |              |             |       |       | 200m (660ft) | 150m (490ft) | 100m (330ft) | 75m (245ft) | 50m (165ft) | 37m (120ft) |              |              |             |             |             |        |
| 200m (660ft)                   |   |              |              |             |       |       |              |              |              |             |             |             | 150m (490ft) | 100m (330ft) | 75m (245ft) | 50m (165ft) | 37m (120ft) |        |
|                                |   |              |              |             |       |       |              |              |              |             |             |             |              |              |             |             |             | SP2201 |
|                                |   |              |              |             |       |       |              |              |              |             |             |             |              |              |             |             |             | SP2202 |
|                                |   |              |              |             |       |       |              |              |              |             |             |             |              |              |             |             |             | SP2203 |
|                                | SP3201  |              |              |             |       |       |              |              |              |             |             |             |              |              |             |             |             |        |
| SP3202                         |   |              |              |             |       |       |              |              |              |             |             |             |              |              |             |             |             |        |
| SP4201                         | 250m (820ft)  | 185m (607ft) | 125m (410ft) | 90m (295ft) |       |       |              |              |              |             |             |             |              |              |             |             |             |        |
| SP4202                         |   |              |              |             |       |       |              |              |              |             |             |             |              |              |             |             |             |        |
| SP4203                         |   |              |              |             |       |       |              |              |              |             |             |             |              |              |             |             |             |        |

**Table 12-25 Maximum motor cable lengths (400V drives)**

| 400V Nominal AC supply voltage |  |               |              |             |             |             |
|--------------------------------|--|---------------|--------------|-------------|-------------|-------------|
| Model                          | Maximum permissible motor cable length for each of the following frequencies |               |              |             |             |             |
|                                | 3kHz   | 4kHz          | 6kHz         | 8kHz        | 12kHz       | 16kHz       |
| SP1401                         | 65m (210ft)  |               |              |             |             |             |
| SP1402                         | 100m (330ft)   |               |              |             |             |             |
| SP1403                         | 130m (425ft)   |               |              |             |             |             |
| SP1404                         | 200m (660ft)   | 150m (490ft)  | 100m (330ft) | 75m (245ft) | 50m (165ft) | 37m (120ft) |
| SP1405                         |  |               |              |             |             |             |
| SP1406                         |  |               |              |             |             |             |
| SP2401                         |  |               |              |             |             |             |
| SP2402                         |  |               |              |             |             |             |
| SP2403                         |  |               |              |             |             |             |
| SP2404                         |  |               |              |             |             |             |
| SP3401                         |  |               |              |             |             |             |
| SP3402                         |  |               |              |             |             |             |
| SP3403                         |  |               |              |             |             |             |
| SP4401                         | 250m (820ft)   | 185m (607ft)  | 125m (410ft) | 90m (295ft) |             |             |
| SP4402                         |  |               |              |             |             |             |
| SP4403                         |  |               |              |             |             |             |
| SP5401                         |  |               |              |             |             |             |
| SP5402                         |  |               |              |             |             |             |
| SP6401                         |  |               |              |             |             |             |
| SP6402                         |  |               |              |             |             |             |
| SP8411                         | 500m (1640ft)  | 370m (1214ft) | 250m (820ft) |             |             |             |
| SP8412                         |  |               |              |             |             |             |
| SP8413                         |  |               |              |             |             |             |
| SP8414                         |  |               |              |             |             |             |
| SP9411                         |  |               |              |             |             |             |
| SP9412                         |  |               |              |             |             |             |
| SP9413                         |  |               |              |             |             |             |
| SP9414                         |  |               |              |             |             |             |
| SP9415                         |  |               |              |             |             |             |

**Table 12-26 Maximum motor cable lengths (575V drives)**

| 575V Nominal AC supply voltage |  |              |              |             |       |       |
|--------------------------------|--|--------------|--------------|-------------|-------|-------|
| Model                          | Maximum permissible motor cable length for each of the following frequencies |              |              |             |       |       |
|                                | 3kHz   | 4kHz         | 6kHz         | 8kHz        | 12kHz | 16kHz |
| SP3501                         | 200m (660ft)   | 150m (490ft) | 100m (330ft) | 75m (245ft) |       |       |
| SP3502                         |  |              |              |             |       |       |
| SP3503                         |  |              |              |             |       |       |
| SP3504                         |  |              |              |             |       |       |
| SP3505                         |  |              |              |             |       |       |
| SP3506                         |  |              |              |             |       |       |
| SP3507                         |  |              |              |             |       |       |

**Table 12-27 Maximum motor cable lengths (690V drives)**

| 690V Nominal AC supply voltage |  |              |              |             |       |       |
|--------------------------------|--|--------------|--------------|-------------|-------|-------|
| Model                          | Maximum permissible motor cable length for each of the following frequencies |              |              |             |       |       |
|                                | 3kHz   | 4kHz         | 6kHz         | 8kHz        | 12kHz | 16kHz |
| SP4601                         | 250m (820ft)   | 185m (607ft) | 125m (410ft) | 90m (295ft) |       |       |
| SP4602                         |  |              |              |             |       |       |
| SP4603                         |  |              |              |             |       |       |
| SP4604                         |  |              |              |             |       |       |
| SP4605                         |  |              |              |             |       |       |
| SP4606                         |  |              |              |             |       |       |
| SP5601                         |  |              |              |             |       |       |
| SP5602                         |  |              |              |             |       |       |
| SP6601                         |  |              |              |             |       |       |
| SP6602                         |  |              |              |             |       |       |

- Cable lengths in excess of the specified values may be used only when special techniques are adopted; refer to the supplier of the drive.
- The default switching frequency is 3kHz for Open-loop and Closed-loop vector, and 6kHz for Servo.

The maximum cable length is reduced from that shown in Table 12-24 and Table 12-25 if high capacitance motor cables are used. For further information, refer to section *High-capacitance cables* on page 79.

**12.1.21 Braking resistor values**

**Table 12-28 Minimum resistance values and peak power rating for the braking resistor at 40°C (104°F)**

| Model            | Minimum resistance*<br>Ω | Instantaneous power rating<br>kW |
|------------------|--------------------------|----------------------------------|
| SP1201 to SP1203 | 43                       | 3.5                              |
| SP1204           | 29                       | 5.3                              |
| SP2201 to SP2203 | 18                       | 8.9                              |
| SP3201 to SP3202 | 5                        | 30.3                             |
| SP4201 to SP4203 | 5                        | 30.3                             |
| SP1401 to SP1404 | 74                       | 8.3                              |
| SP1405 to SP1406 | 58                       | 10.6                             |
| SP2401 to SP2404 | 19                       | 33.1                             |
| SP3401 to SP3403 | 18                       | 35.5                             |
| SP4401 to SP4402 | 11                       | 55.3                             |
| SP4403           | 9                        | 67.6                             |
| SP5401 to SP5402 | 7                        | 86.9                             |
| SP6401 to SP6402 | 5                        | 121.7                            |
| SP6411 to SP6412 |                          |                                  |
| SP3501 to SP3507 | 18                       | 50.7                             |
| SP4601 to SP4606 | 13                       | 95                               |
| SP5601 to SP5602 | 10                       | 125.4                            |
| SP6601 to SP6602 |                          |                                  |
| SP6611 to SP6612 |                          |                                  |

\* Resistor tolerance: ±10%

## 12.1.22 Torque settings

**Table 12-29 Drive control and relay terminal data**

| Model | Connection type        | Torque setting    |
|-------|------------------------|-------------------|
| All   | Plug-in terminal block | 0.5 N m 0.4 lb ft |

**Table 12-30 Wall mounted drive power terminal data**

| Model size       | AC terminals                                     | High current DC and braking                          | Low voltage DC                                       | Ground terminal                   |
|------------------|--|--|--|-----------------------------------|
| 1                | Plug-in terminal block<br>1.5 N m<br>(1.1 lb ft) | Terminal block (M4 screws)<br>1.5 N m (1.1 lb ft)    |  | Stud (M5)<br>4.0 N m<br>2.9 lb ft |
| 2                |  | Terminal block (M5 screws)<br>1.5 N m<br>(1.1 lb ft) | Terminal block (M4 screws)<br>1.5 N m<br>(1.1 lb ft) |                                   |
| 3                | Terminal block (M6 screws)<br>2.5 N m 1.8 lb ft  |  | M10 stud<br>15 N m<br>(11.1 lb ft)                   | 6.0 N m<br>4.4 lb ft              |
| 4                | M10 stud   |  |  | M10 stud                          |
| 5                | 15 N m   |  |  | 15 N m                            |
| 6                | (11.1 lb ft)                                     |  |  | (11.1 lb ft)                      |
| Torque tolerance |  |  |  | ±10%                              |

**Table 12-31 Free standing cubicle drive terminal data**

| Model size       | AC terminals   | High current DC and braking | Low voltage DC | Ground terminal |
|------------------|--|-----------------------------|----------------|-----------------|
| 8                | 2 x M10 clearance holes per phase for parallel cables. |                             |                | 15 N m          |
| 9                | 15 N m (11.1 lb ft)<br>Nut and bolt not supplied.      |                             |                | 15 N m          |
| Torque tolerance |  |                             |                | ±10%            |

## 12.1.23 Electromagnetic compatibility (EMC)

This is a summary of the EMC performance of the drive. For full details, refer to the *Unidrive SP EMC Data Sheet* which can be obtained from the supplier of the drive.

**Table 12-32 Immunity compliance**

| Standard                                 | Type of immunity   | Test specification  | Application   | Level                      |
|--|--|---|---|----------------------------|
| IEC61000-4-2<br>EN61000-4-2              | Electrostatic discharge  | 6kV contact discharge<br>8kV air discharge                            | Module enclosure  | Level 3 (industrial)       |
| IEC61000-4-3<br>EN61000-4-3              | Radio frequency radiated field   | 10V/m prior to modulation<br>80 - 1000MHz<br>80% AM (1kHz) modulation | Module enclosure  | Level 3 (industrial)       |
| IEC61000-4-4<br>EN61000-4-4              | Fast transient burst   | 5/50ns 2kV transient at 5kHz repetition frequency via coupling clamp  | Control lines   | Level 4 (industrial harsh) |
|  |  | 5/50ns 2kV transient at 5kHz repetition frequency by direct injection | Power lines   | Level 3 (industrial)       |
| IEC61000-4-5<br>EN61000-4-5              | Surges   | Common mode 4kV 1.2/50µs waveshape                                    | AC supply lines: line to ground                               | Level 4                    |
|  |  | Differential mode 2kV 1.2/50µs waveshape                              | AC supply lines: line to line                                 | Level 3                    |
|  |  | Lines to ground   | Signal ports to ground <sup>1</sup>                           | Level 2                    |
| IEC61000-4-6<br>EN61000-4-6              | Conducted radio frequency  | 10V prior to modulation<br>0.15 - 80MHz<br>80% AM (1kHz) modulation   | Control and power lines                                       | Level 3 (industrial)       |
| IEC61000-4-11<br>EN61000-4-11            | Voltage dips and interruptions   | -30% 10ms<br>+60% 100ms<br>-60% 1s<br><-95% 5s                        | AC power ports  |                            |
| EN50082-1<br>IEC61000-6-1<br>EN61000-6-1 | Generic immunity standard for the residential, commercial and light - industrial environment |   |   | Complies                   |
| EN50082-2<br>IEC61000-6-2<br>EN61000-6-2 | Generic immunity standard for the industrial environment                                     |   |   | Complies                   |
| EN61800-3<br>IEC61800-3<br>EN61800-3     | Product standard for adjustable speed power drive systems (immunity requirements)            |   | Meets immunity requirements for first and second environments |                            |

<sup>1</sup> See section *Surge immunity of control circuits - long cables and connections outside a building* on page 90 for control ports for possible requirements regarding grounding and external surge protection

### Emission

The drive contains an in-built filter for basic emission control. An additional optional external filter provides further reduction of emission. The requirements of the following standards are met, depending on the motor cable length and switching frequency.

**Table 12-33 Size 1 emission compliance**

| Motor cable length (m)                           | Switching frequency (kHz) |     |   |     |    |    |
|--|---------------------------|-----|---|-----|----|----|
|  | 3                         | 4   | 6 | 8   | 12 | 16 |
| Using internal filter:                           |                           |     |   |     |    |    |
| 0 to 4   | E2U                       | E2R |   |     |    |    |
| >4   | E2R                       |     |   |     |    |    |
| Using internal filter and external ferrite ring: |                           |     |   |     |    |    |
| 0 to 10  | E2U                       |     |   | E2R |    |    |
| > 10   | E2R                       |     |   |     |    |    |
| Using external filter:                           |                           |     |   |     |    |    |
| 0 to 25  | R                         |     | I |     |    |    |
| 25 to 75   |                           |     | I |     |    |    |
| 75 to 100  | I                         |     |   |     |    |    |

**Table 12-34 Size 2 emission compliance**

| Motor cable length (m)                           | Switching frequency (kHz) |     |   |     |    |    |
|--|---------------------------|-----|---|-----|----|----|
|  | 3                         | 4   | 6 | 8   | 12 | 16 |
| Using internal filter:                           |                           |     |   |     |    |    |
| Any  | E2R                       |     |   |     |    |    |
| Using internal filter and external ferrite ring: |                           |     |   |     |    |    |
| 0 to 4   | E2U                       |     |   | E2R |    |    |
| 4 to 10  | E2U                       | E2R |   |     |    |    |
| > 10   | E2R                       |     |   |     |    |    |
| Using external filter:                           |                           |     |   |     |    |    |
| 0 to 25  | R                         |     | I |     |    |    |
| 25 to 75   |                           |     | I |     |    |    |
| 75 to 100  | I                         |     |   |     |    |    |

**Table 12-35 Size 3 (200V and 400V only) emission compliance**

| Motor cable length (m)                           | Switching frequency (kHz) |     |   |   |    |
|--|---------------------------|-----|---|---|----|
|  | 3                         | 4   | 6 | 8 | 12 |
| Using internal filter:                           |                           |     |   |   |    |
| Any  | E2R                       |     |   |   |    |
| Using internal filter and external ferrite ring: |                           |     |   |   |    |
| 0 to 10  | E2U                       | E2R |   |   |    |
| > 10   | E2R                       |     |   |   |    |
| Using external filter:                           |                           |     |   |   |    |
| 0 to 20  | R                         | I   |   |   |    |
| 20 to 50   |                           |     | I |   |    |
| 50 to 75   |                           |     | I |   |    |
| 75 to 100  | I                         |     |   |   |    |

**Table 12-36 Size 4 (400V only) emission compliance**

| Motor cable length (m) | Switching frequency (kHz) |     |   |   |
|------------------------|---------------------------|-----|---|---|
|                        | 3                         | 4   | 6 | 8 |
| Using internal filter: |                           |     |   |   |
| Any                    | E2R                       |     |   |   |
| Using external filter: |                           |     |   |   |
| 0 to 25                |                           |     | I |   |
| 20 to 50               |                           |     | I |   |
| 50 to 75               | I                         | E2U |   |   |
| 75 to 100              | I                         | E2U |   |   |

**Key** (shown in decreasing order of permitted emission level):

- E2R EN 61800-3 second environment, restricted distribution (Additional measures may be required to prevent interference)
- E2U EN 61800-3 second environment, unrestricted distribution

I Industrial generic standard EN 50081-2 (EN 61000-6-4) EN 61800-3 first environment restricted distribution (The following caution is required by EN 61800-3)



This is a product of the restricted distribution class according to IEC 61800-3. In a domestic environment this product may cause radio interference in which case the user may be required to take adequate measures.

R Residential generic standard EN 50081-1 (EN 61000-6-3) EN 61800-3 first environment unrestricted distribution

EN 61800-3 defines the following:

- The first environment is one that includes domestic premises. It also includes establishments directly connected without intermediate transformers to a low-voltage power supply network which supplies buildings used for domestic purposes.
- The second environment is one that includes all establishments other than those directly connected to a low-voltage power supply network which supplies buildings used for domestic purposes.
- Restricted distribution is defined as a mode of sales distribution in which the manufacturer restricts the supply of equipment to suppliers, customers or users who separately or jointly have technical competence in the EMC requirements of the application of drives.

## 12.2 Optional external EMC filters

**Table 12-37 Unidrive SP and EMC filter cross reference**

| Drive            | Schaffner   | Epcos       |
|------------------|-------------|-------------|
|                  | CT part no. | CT part no. |
| SP1201 to SP1202 | 4200-6118   | 4200-6121   |
| SP1203 to SP1204 | 4200-6119   | 4200-6120   |
| SP2201 to SP2203 | 4200-6210   | 4200-6211   |
| SP3201 to SP3202 | 4200-6307   | 4200-6306   |
| SP4201 to SP4203 | 4200-6406   | 4200-6405   |
| SP1401 to SP1404 | 4200-6118   | 4200-6121   |
| SP1405 to SP1406 | 4200-6119   | 4200-6120   |
| SP2401 to SP2404 | 4200-6210   | 4200-6211   |
| SP3401 to SP3403 | 4200-6305   | 4200-6306   |
| SP4401 to SP4403 | 4200-6406   | 4200-6405   |
| SP5401 to SP5402 | 4200-6503   | 4200-6501   |
| SP6401 to SP6402 | 4200-6603   | 4200-6601   |
| SP3501 to SP3507 | 4200-6309   | 4200-6308   |
| SP4601 to SP4606 | 4200-6408   | 4200-6407   |
| SP5601 to SP5602 | 4200-6504   | 4200-6502   |
| SP6601 to SP6602 | 4200-6604   | 4200-6602   |

For free standing cubicle drives (size 8 and 9), EMC filters can be sourced directly from Schaffner and Epcos. See Table 12-38 for details.

**Table 12-38 Free standing cubicle drive EMC filter details (size 8 and 9)**

| Drive  | Power (kW) | Input (A) | Filter rating (A) | Filter (V) | Epcos part number | Schaffner part number |
|--------|------------|-----------|-------------------|------------|-------------------|-----------------------|
| SP8411 | 185/200    | 408       | 600               | 415        | B84143-B600-S20   | FN3359-600-99         |
| SP8412 | 225/250    | 467       | 600               | 415        | B84143-B600-S20   | FN3359-600-99         |
| SP8413 | 250/315    | 576       | 600               | 415        | B84143-B600-S20   | FN3359-600-99         |
| SP8414 | 315/355    | 678       | 1000              | 415        | B84143-B1000-S20  | FN3359-1000-99        |
| SP9411 | 355/400    | 864       | 1000              | 415        | B84143-B1000-S20  | FN3359-1000-99        |
| SP9412 | 400/450    | 864       | 1000              | 415        | B84143-B1000-S20  | FN3359-1000-99        |
| SP9413 | 450/500    | 935       | 1000              | 415        | B84143-B1000-S20  | FN3359-1000-99        |
| SP9414 | 500/560    | 1151      | 1600              | 415        | B84143-B1600-S20  | FN3359-1600-99        |
| SP9415 | 560/675    | 1356      | 1600              | 415        | B84143-B1600-S20  | FN3359-1600-99        |

## 12.2.1 EMC filter ratings

Table 12-39 Optional external EMC filter details

| CT part number | Manufacturer | Maximum continuous current |                     | Voltage rating<br>V | IP rating | Power dissipation at rated current<br>W | Ground leakage   |                  | Discharge resistors |            |
|----------------|--------------|----------------------------|---------------------|---------------------|-----------|---|--|------------------|---------------------|------------|
|                |              | @ 40°C (104°F)<br>A        | @ 50°C (122°F)<br>A |                     |           |   | Balanced supply phase-to-phase and phase-to-ground<br>mA | Worst case<br>mA |                     |            |
| 4200-6118      | Schaffner    | 10                         | 10                  | 400                 | 20        | 6.9                                     | 29.4   | 153              | See Note 1          |            |
| 4200-6119      |              | 16                         | 16                  |                     |           | 9.2                                     | 38.8   | 277              |                     |            |
| 4200-6210      |              | 32                         | 28.2                |                     |           | 11                                      | 38.0   | 206              |                     |            |
| 4200-6305      |              | 62                         | 56.6                | 23                  |           | 66.0                                    | 357  |                  |                     |            |
| 4200-6307      |              | 75                         | 68.5                | 29                  |           | 24.0                                    | 170  |                  |                     |            |
| 4200-6309      |              | 30                         | 30                  | 15                  |           | 102.0                                   | 557  | See Note 3       |                     |            |
| 4200-6406      |              | 101                        | 92.2                | 25                  |           | 73.0                                    | 406  | See Note 1       |                     |            |
| 4200-6408      |              | 58                         | 52.8                | 31                  |           | 66.0                                    | 344  | See Note 1       |                     |            |
| 4200-6503      |              | 164                        | 150                 | 30                  |           | 39.1                                    | 216  | See Note 4       |                     |            |
| 4200-6504      |              | 95                         | 86.7                | 30                  |           | 66.0                                    | 344  | See Note 1       |                     |            |
| 4200-6603      |              | 260                        | 237                 | 480                 | 00        | 14.2                                    | 41.0   | 219              | See Note 1          |            |
| 4200-6604      |              |                            |                     |                     |           |   |  |                  |                     |            |
| 4200-6121      |              | Epcos                      | 10                  | 9.1                 | 400       | 20                                      | 4.2  | <30.0            | 186.5               | See Note 2 |
| 4200-6120      | 16           |                            | 14.6                | 10.8                |           |   |  |                  |                     |            |
| 4200-6211      | 32           |                            | 29.1                | 17.8                |           |   |  |                  |                     |            |
| 4200-6306      | 75           |                            | 68.3                | 19.4                |           |   | 238  |                  |                     |            |
| 4200-6308      | 30           |                            | 22.5                | 660                 | 17.6      |   | <35.0  | 230              |                     |            |
| 4200-6405      | 101          |                            | 75                  | 480                 | 30        |   | <30.0  | 180              |                     |            |
| 4200-6407      | 58           |                            | 44                  | 690                 | 15        |   | <40.0  | <340             | See Note 5          |            |
| 4200-6501      | 165          |                            | 125                 | 480                 | 27        |   | <20.0  | <120             | See Note 2          |            |
| 4200-6502      | 95           |                            | 71                  | 690                 | 19        |   | <55.0  | <450             | See Note 5          |            |
| 4200-6601      |              |                            |                     |                     |           |   |  |                  |                     |            |
| 4200-6602      |              |                            |                     |                     |           |   |  |                  |                     |            |

### NOTE

1. 1MΩ in a star connection between phases, with the star point connected by a 680kΩ resistor to ground (i.e. line to line 2MΩ, line to ground 1.68MΩ)
2. 1MΩ in a star connection between phases, with the star point connected by a 1.5MΩ resistor to ground (i.e. line to line 2MΩ, line to ground 2.5MΩ)
3. 2MΩ between phases with each phase connected by a 660kΩ resistance to ground.
4. 1.5MΩ in a star connection between phases, with the star point connected by a 680kΩ resistor to ground (i.e. line to line 3MΩ, line to ground 2.18MΩ)
5. 1.8MΩ in a star connection between phases, with the star point connected by a 1.5MΩ resistor to ground (i.e. line to line 3.6MΩ, line to ground 3.3MΩ)

## 12.2.2 Overall EMC filter dimensions

Table 12-40 Optional external EMC filter dimensions

| CT part number | Manufacturer         | Dimension            |                    |                   | Weight           |      |                   |      |      |
|----------------|----------------------|----------------------|--------------------|-------------------|------------------|------|-------------------|------|------|
|                |                      | H                    | W                  | D                 | kg               | lb   |                   |      |      |
| 4200-6118      | Schaffner            | 440 mm (17.323 in)   | 100 mm (3.937 in)  | 45 mm (1.772 in)  | 1.4              | 3.1  |                   |      |      |
| 4200-6119      |                      |                      |                    |                   |                  |      |                   |      |      |
| 4200-6210      |                      | 428.5 mm (16.870 in) | 155 mm (6.102 in)  | 55 mm (2.165 in)  | 2                | 4.4  |                   |      |      |
| 4200-6305      |                      | 414 mm (16.299 in)   | 250 mm (9.842 in)  | 60 mm (2.362 in)  | 3.5              | 7.7  |                   |      |      |
| 4200-6307      |                      |                      |                    |                   |                  |      |                   |      |      |
| 4200-6309      |                      | 300 mm (11.811 in)   | 225 mm (8.858 in)  | 100 mm (3.937 in) | 4                | 8.8  |                   |      |      |
| 4200-6406      |                      |                      |                    |                   |                  |      |                   |      |      |
| 4200-6408      |                      |                      |                    |                   |                  |      | 208 mm (8.189 in) | 3.8  | 8.4  |
| 4200-6503      |                      |                      |                    |                   |                  |      | 249 mm (9.803 in) | 6.8  | 15   |
| 4200-6504      |                      |                      |                    |                   |                  |      | 225 mm (8.858 in) | 4.4  | 9.7  |
| 4200-6603      |                      | 135 mm (5.315 in)    | 295 mm (11.614 in) | 230 mm (9.055 in) | 5.25             | 11.6 |                   |      |      |
| 4200-6604      |                      |                      |                    |                   |                  |      |                   |      |      |
| 4200-6121      |                      | Epcos                | 450 mm (17.717 in) | 100 mm (3.937 in) | 45 mm (1.772 in) | 2.1  | 4.6               |      |      |
| 4200-6120      |                      |                      |                    |                   |                  |      |                   |      |      |
| 4200-6211      | 431.5 mm (16.988 in) |                      | 155 mm (6.102 in)  | 55 mm (2.165 in)  | 3.3              | 7.3  |                   |      |      |
| 4200-6306      | 425 mm (16.732 in)   |                      | 250 mm (9.843 in)  | 60 mm (2.362 in)  | 5.1              | 11.2 |                   |      |      |
| 4200-6308      |                      |                      |                    |                   |                  |      |                   |      |      |
| 4200-6405      | 300 mm (11.811 in)   |                      | 207 mm (8.150 in)  | 90 mm (3.543 in)  | 7.8              | 17.2 |                   |      |      |
| 4200-6407      |                      |                      |                    |                   |                  |      | 205 mm (8.071 in) | 8.0  | 17.6 |
| 4200-6501      |                      |                      |                    |                   |                  |      | 249 mm (9.803 in) | 12.0 | 26.5 |
| 4200-6502      |                      |                      |                    | 120 mm (4.724 in) | 10.0             | 22.0 |                   |      |      |
| 4200-6601      |                      |                      |                    |                   |                  |      |                   |      |      |
| 4200-6602      |                      |                      |                    |                   |                  |      |                   |      |      |

## 12.2.3 EMC filter torque settings

Table 12-41 Optional external EMC Filter terminal data

| CT part number | Manufacturer           | Power connections        |                        | Ground connections  |                     |
|----------------|------------------------|--------------------------|------------------------|---------------------|---------------------|
|                |                        | Max cable size           | Max torque             | Ground stud size    | Max torque          |
| 4200-6118      | Schaffner              | 4mm <sup>2</sup> 12AWG   | 0.8 N m (0.6 lb ft)    | M5                  | 3.5 N m (2.6 lb ft) |
| 4200-6119      |                        |                          |                        |                     |                     |
| 4200-6210      |                        | 10mm <sup>2</sup> 8AWG   | 2.0 N m (1.5 lb ft)    |                     |                     |
| 4200-6305      |                        | 16mm <sup>2</sup> 6AWG   | 2.2 N m (1.6 lb ft)    | M6                  | 3.9 N m (2.9 lb ft) |
| 4200-6307      |                        |                          |                        |                     |                     |
| 4200-6309      |                        | 50mm <sup>2</sup> 0AWG   | 8 N m (5.9 lb ft)      | M10                 | 25 N m (18.4 lb ft) |
| 4200-6406      |                        |                          |                        |                     |                     |
| 4200-6408      |                        |                          |                        |                     |                     |
| 4200-6503      |                        | 95mm <sup>2</sup> 4/0AWG | 20 N m (14.7 lb ft)    | M10                 | 25 N m (18.4 lb ft) |
| 4200-6504      |                        | 50mm <sup>2</sup> 0AWG   | 8 N m (5.9 lb ft)      |                     |                     |
| 4200-6603      |                        |                          | 12 N m (8.8 lb ft)     |                     |                     |
| 4200-6604      |                        |                          |                        |                     |                     |
| 4200-6120      |                        | Epcos                    | 4mm <sup>2</sup> 12AWG | 0.6 N m (0.4 lb ft) | M5                  |
| 4200-6121      |                        |                          |                        |                     |                     |
| 4200-6211      | 10mm <sup>2</sup> 8AWG |                          | 1.35 N m (1.0 lb ft)   |                     |                     |
| 4200-6306      | 16mm <sup>2</sup> 6AWG |                          | 2.2 N m (1.6 lb ft)    | M6                  | 5.1 N m (3.8 lb ft) |
| 4200-6308      |                        |                          |                        |                     |                     |
| 4200-6405      | 50mm <sup>2</sup> 0AWG |                          | 6.8 N m (5.0 lb ft)    | M10                 | 10 N m (7.4 lb ft)  |
| 4200-6407      |                        |                          |                        |                     |                     |
| 4200-6501      |                        |                          |                        |                     |                     |
| 4200-6502      |                        |                          |                        |                     |                     |
| 4200-6601      |                        |                          |                        |                     |                     |
| 4200-6602      |                        |                          |                        |                     |                     |

# 13 Diagnostics

The display on the drive gives various information about the status of the drive. These fall into three categories:

- Trip indications
- Alarm indications
- Status indications



Users must not attempt to repair a drive if it is faulty, nor carry out fault diagnosis other than through the use of the diagnostic features described in this chapter. If a drive is faulty, it must be returned to an authorized Control Techniques distributor for repair.

## 13.1 Trip indications

If the drive trips, the output of the drive is disabled so that the drive stops controlling the motor. The lower display indicates that a trip has occurred and the upper display shows the trip. If this is a multi-module drive and a power module has indicated a trip, then the upper display will alternate between the trip string and the module number.

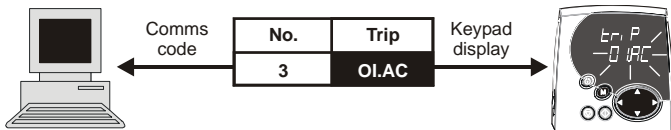
Trips are listed alphabetically in Table 13-1 based on the trip indication shown on the drive display. Refer to Figure 13-1.

If a display is not used, the drive LED Status indicator will flash if the drive has tripped. Refer to Figure 13-2.

The trip indication can be read in Pr 10.20 providing a trip number. Trip numbers are listed in numerical order in Table 13-2 so the trip indication can be cross referenced and then diagnosed using Table 13-1.

### Example

1. Trip code 3 is read from Pr 10.20 via serial communications.
2. Checking Table 13-2 shows Trip 3 is an OI.AC trip.



3. Look up OI.AC in Table 13-1.
4. Perform checks detailed under *Diagnosis*.

Figure 13-1 Keypad status modes

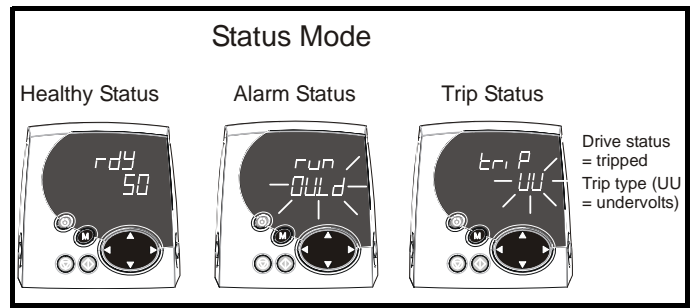
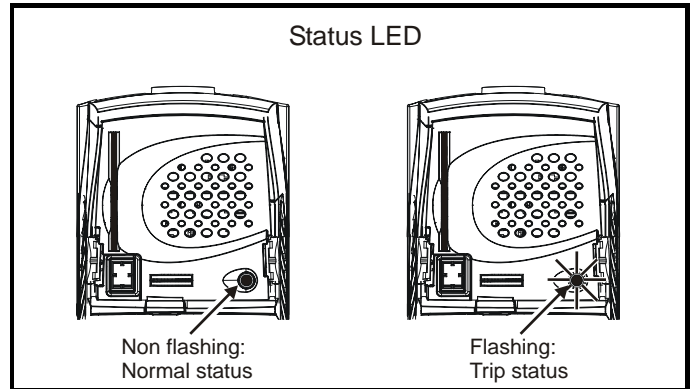





Figure 13-2 Location of the status LED



| Trip  | Diagnosis   |
|-------|---|
| OI.AC | <b>Instantaneous output over current detected: peak output current greater than 225%</b>  |
| 3     | Acceleration / deceleration rate is too short.<br>If seen during autotune reduce voltage boost Pr 5.15<br>Check for short circuit on output cabling<br>Check integrity of motor insulation<br>Check feedback device wiring<br>Check feedback device mechanical coupling<br>Check feedback signals are free from noise<br>Is motor cable length within limits for that frame size?<br>Reduce the values in speed loop gain parameters – Pr 3.10, Pr 3.11 and Pr 3.12 (closed loop vector and servo modes only)<br>Has offset measurement test been completed? (servo mode only)<br>Reduce the values in current loop gain parameters - Pr 4.13 and Pr 4.14 (closed loop vector and servo modes only) |

**Table 13-1 Trip indications**

| Trip          | Diagnosis  |
|---------------|--|
| <b>C.Acc</b>  | <b>SMARTCARD trip: SMARTCARD Read / Write fail</b>   |
| 185           | Check SMARTCARD is fitted / located correctly<br>Replace SMARTCARD   |
| <b>C.boot</b> | <b>SMARTCARD trip: The menu 0 parameter modification cannot be saved to the SMARTCARD because the necessary file has not been created on the SMARTCARD</b>   |
| 177           | A write to a menu 0 parameter has been initiated via the keypad with Pr 11.42 set to auto(3) or boot(4), but the necessary file on the SMARTCARD has not been created<br>Ensure that Pr 11.42 is correctly set and reset the drive to create the necessary file on the SMARTCARD<br>Re-attempt the parameter write to the menu 0 parameter |
| <b>C.bUSY</b> | <b>SMARTCARD trip: SMARTCARD can not perform the required function as it is being accessed by a Solutions Module</b>   |
| 178           | Wait for the Solutions Module to finish accessing the SMARTCARD and then re-attempt the required function  |
| <b>C.Chg</b>  | <b>SMARTCARD trip: Data location already contains data</b>   |
| 179           | Erase data in data location<br>Write data to an alternative data location  |
| <b>C.cPr</b>  | <b>SMARTCARD trip: The values stored in the drive and the values in the data block on the SMARTCARD are different</b>  |
| 188           | Press the red  reset button   |
| <b>C.dAt</b>  | <b>SMARTCARD trip: Data location specified does not contain any data</b>   |
| 183           | Ensure data block number is correct  |
| <b>C.Err</b>  | <b>SMARTCARD trip: SMARTCARD data is corrupted</b>   |
| 182           | Ensure the card is located correctly<br>Erase data and retry<br>Replace SMARTCARD  |
| <b>C.Full</b> | <b>SMARTCARD trip: SMARTCARD full</b>  |
| 184           | Delete a data block or use different SMARTCARD   |
| <b>cL2</b>    | <b>Analogue input 2 current loss (current mode)</b>  |
| 28            | Check analogue input 2 (terminal 7) current signal is present (4-20mA, 20-4mA)   |
| <b>cL3</b>    | <b>Analogue input 3 current loss (current mode)</b>  |
| 29            | Check analogue input 3 (terminal 8) current signal is present (4-20mA, 20-4mA)   |
| <b>CL.bit</b> | <b>Trip initiated from the control word (Pr 6.42)</b>  |
| 35            | Disable the control word by setting Pr 6.43 to 0 or check setting of Pr 6.42   |
| <b>C.OPtn</b> | <b>SMARTCARD trip: Solutions Modules fitted are different between source drive and destination drive</b>   |
| 180           | Ensure correct Solutions Modules are fitted<br>Ensure Solutions Modules are in the same Solutions Module slot<br>Press the red  reset button  |
| <b>C.rdo</b>  | <b>SMARTCARD trip: SMARTCARD has the Read Only bit set</b>   |
| 181           | Enter 9777 in Pr <b>xx.00</b> to allow SMARTCARD Read / Write access<br>Ensure card is not writing to data locations 500 to 999  |

| Trip                | Diagnosis   |           |          |      |                       |                     |                |      |                              |             |                     |             |                     |             |                    |             |                   |      |                     |             |                |             |                      |             |                   |      |                              |      |   |
|---------------------|---|-----------|----------|------|-----------------------|---------------------|----------------|------|------------------------------|-------------|---------------------|-------------|---------------------|-------------|--------------------|-------------|-------------------|------|---------------------|-------------|----------------|-------------|----------------------|-------------|-------------------|------|------------------------------|------|---|
| <b>C.rtg</b>        | <b>SMARTCARD trip: SMARTCARD attempting to change the destination drive ratings<br/>No drive rating parameters have been transferred</b>  |           |          |      |                       |                     |                |      |                              |             |                     |             |                     |             |                    |             |                   |      |                     |             |                |             |                      |             |                   |      |                              |      |   |
| 186                 | <p>Press the red  reset button<br/>Drive rating parameters are:</p> <table border="1"> <thead> <tr> <th>Parameter</th> <th>Function</th> </tr> </thead> <tbody> <tr> <td>2.08</td> <td>Standard ramp voltage</td> </tr> <tr> <td>4.05/6/7, 21.27/8/9</td> <td>Current limits</td> </tr> <tr> <td>4.24</td> <td>User current maximum scaling</td> </tr> <tr> <td>5.07, 21.07</td> <td>Motor rated current</td> </tr> <tr> <td>5.09, 21.09</td> <td>Motor rated voltage</td> </tr> <tr> <td>5.10, 21.10</td> <td>Rated power factor</td> </tr> <tr> <td>5.17, 21.12</td> <td>Stator resistance</td> </tr> <tr> <td>5.18</td> <td>Switching frequency</td> </tr> <tr> <td>5.23, 21.13</td> <td>Voltage offset</td> </tr> <tr> <td>5.24, 21.14</td> <td>Transient inductance</td> </tr> <tr> <td>5.25, 21.24</td> <td>Stator inductance</td> </tr> <tr> <td>6.06</td> <td>DC injection braking current</td> </tr> <tr> <td>6.48</td> <td>Mains loss ride through detection level</td> </tr> </tbody> </table> <p>The above parameters will be set to their default values.</p> | Parameter | Function | 2.08 | Standard ramp voltage | 4.05/6/7, 21.27/8/9 | Current limits | 4.24 | User current maximum scaling | 5.07, 21.07 | Motor rated current | 5.09, 21.09 | Motor rated voltage | 5.10, 21.10 | Rated power factor | 5.17, 21.12 | Stator resistance | 5.18 | Switching frequency | 5.23, 21.13 | Voltage offset | 5.24, 21.14 | Transient inductance | 5.25, 21.24 | Stator inductance | 6.06 | DC injection braking current | 6.48 | Mains loss ride through detection level |
| Parameter           | Function  |           |          |      |                       |                     |                |      |                              |             |                     |             |                     |             |                    |             |                   |      |                     |             |                |             |                      |             |                   |      |                              |      |   |
| 2.08                | Standard ramp voltage   |           |          |      |                       |                     |                |      |                              |             |                     |             |                     |             |                    |             |                   |      |                     |             |                |             |                      |             |                   |      |                              |      |   |
| 4.05/6/7, 21.27/8/9 | Current limits  |           |          |      |                       |                     |                |      |                              |             |                     |             |                     |             |                    |             |                   |      |                     |             |                |             |                      |             |                   |      |                              |      |   |
| 4.24                | User current maximum scaling  |           |          |      |                       |                     |                |      |                              |             |                     |             |                     |             |                    |             |                   |      |                     |             |                |             |                      |             |                   |      |                              |      |   |
| 5.07, 21.07         | Motor rated current   |           |          |      |                       |                     |                |      |                              |             |                     |             |                     |             |                    |             |                   |      |                     |             |                |             |                      |             |                   |      |                              |      |   |
| 5.09, 21.09         | Motor rated voltage   |           |          |      |                       |                     |                |      |                              |             |                     |             |                     |             |                    |             |                   |      |                     |             |                |             |                      |             |                   |      |                              |      |   |
| 5.10, 21.10         | Rated power factor  |           |          |      |                       |                     |                |      |                              |             |                     |             |                     |             |                    |             |                   |      |                     |             |                |             |                      |             |                   |      |                              |      |   |
| 5.17, 21.12         | Stator resistance   |           |          |      |                       |                     |                |      |                              |             |                     |             |                     |             |                    |             |                   |      |                     |             |                |             |                      |             |                   |      |                              |      |   |
| 5.18                | Switching frequency   |           |          |      |                       |                     |                |      |                              |             |                     |             |                     |             |                    |             |                   |      |                     |             |                |             |                      |             |                   |      |                              |      |   |
| 5.23, 21.13         | Voltage offset  |           |          |      |                       |                     |                |      |                              |             |                     |             |                     |             |                    |             |                   |      |                     |             |                |             |                      |             |                   |      |                              |      |   |
| 5.24, 21.14         | Transient inductance  |           |          |      |                       |                     |                |      |                              |             |                     |             |                     |             |                    |             |                   |      |                     |             |                |             |                      |             |                   |      |                              |      |   |
| 5.25, 21.24         | Stator inductance   |           |          |      |                       |                     |                |      |                              |             |                     |             |                     |             |                    |             |                   |      |                     |             |                |             |                      |             |                   |      |                              |      |   |
| 6.06                | DC injection braking current  |           |          |      |                       |                     |                |      |                              |             |                     |             |                     |             |                    |             |                   |      |                     |             |                |             |                      |             |                   |      |                              |      |   |
| 6.48                | Mains loss ride through detection level   |           |          |      |                       |                     |                |      |                              |             |                     |             |                     |             |                    |             |                   |      |                     |             |                |             |                      |             |                   |      |                              |      |   |
| <b>C.TyP</b>        | <b>SMARTCARD trip: SMARTCARD parameter set not compatible with drive</b>  |           |          |      |                       |                     |                |      |                              |             |                     |             |                     |             |                    |             |                   |      |                     |             |                |             |                      |             |                   |      |                              |      |   |
| 187                 | <p>Press the reset button<br/>Ensure destination drive type is the same as the source parameter file drive type</p>   |           |          |      |                       |                     |                |      |                              |             |                     |             |                     |             |                    |             |                   |      |                     |             |                |             |                      |             |                   |      |                              |      |   |
| <b>dEst</b>         | <b>Two or more parameters are writing to the same destination parameter</b>   |           |          |      |                       |                     |                |      |                              |             |                     |             |                     |             |                    |             |                   |      |                     |             |                |             |                      |             |                   |      |                              |      |   |
| 199                 | Set Pr xx.00 = 12001 check all visible parameters in the menus for duplication  |           |          |      |                       |                     |                |      |                              |             |                     |             |                     |             |                    |             |                   |      |                     |             |                |             |                      |             |                   |      |                              |      |   |
| <b>EEF</b>          | <b>EEPROM data corrupted - Drive mode becomes open loop and serial comms will timeout with remote keypad on the drive<br/>RS485 comms port.</b>   |           |          |      |                       |                     |                |      |                              |             |                     |             |                     |             |                    |             |                   |      |                     |             |                |             |                      |             |                   |      |                              |      |   |
| 31                  | This trip can only be cleared by loading default parameters and saving parameters   |           |          |      |                       |                     |                |      |                              |             |                     |             |                     |             |                    |             |                   |      |                     |             |                |             |                      |             |                   |      |                              |      |   |
| <b>Enc1</b>         | <b>Drive encoder trip: Encoder power supply overload</b>  |           |          |      |                       |                     |                |      |                              |             |                     |             |                     |             |                    |             |                   |      |                     |             |                |             |                      |             |                   |      |                              |      |   |
| 189                 | <p>Check encoder power supply wiring and encoder current requirement<br/>Maximum current = 200mA @ 15V, or 300mA @ 8V and 5V</p>  |           |          |      |                       |                     |                |      |                              |             |                     |             |                     |             |                    |             |                   |      |                     |             |                |             |                      |             |                   |      |                              |      |   |
| <b>Enc2</b>         | <b>Drive encoder trip: Wire break (Drive encoder terminals 1 &amp; 2, 3 &amp; 4, 5 &amp; 6)</b>   |           |          |      |                       |                     |                |      |                              |             |                     |             |                     |             |                    |             |                   |      |                     |             |                |             |                      |             |                   |      |                              |      |   |
| 190                 | <p>Check cable continuity<br/>Check wiring of feedback signals is correct<br/>Check encoder power is set correctly<br/>Replace feedback device<br/>If wire break detection on the main drive encoder input is not required, set Pr 3.40 = 0 to disable the Enc2 trip</p>  |           |          |      |                       |                     |                |      |                              |             |                     |             |                     |             |                    |             |                   |      |                     |             |                |             |                      |             |                   |      |                              |      |   |
| <b>Enc3</b>         | <b>Drive encoder trip: Phase offset incorrect whilst running</b>  |           |          |      |                       |                     |                |      |                              |             |                     |             |                     |             |                    |             |                   |      |                     |             |                |             |                      |             |                   |      |                              |      |   |
| 191                 | <p>Check the encoder signal for noise<br/>Check encoder shielding<br/>Check the integrity of the encoder mechanical mounting<br/>Repeat the offset measurement test</p>   |           |          |      |                       |                     |                |      |                              |             |                     |             |                     |             |                    |             |                   |      |                     |             |                |             |                      |             |                   |      |                              |      |   |
| <b>Enc4</b>         | <b>Drive encoder trip: Feedback device comms failure</b>  |           |          |      |                       |                     |                |      |                              |             |                     |             |                     |             |                    |             |                   |      |                     |             |                |             |                      |             |                   |      |                              |      |   |
| 192                 | <p>Ensure encoder power supply is correct<br/>Ensure baud rate is correct<br/>Check encoder wiring<br/>Replace feedback device</p>  |           |          |      |                       |                     |                |      |                              |             |                     |             |                     |             |                    |             |                   |      |                     |             |                |             |                      |             |                   |      |                              |      |   |
| <b>Enc5</b>         | <b>Drive encoder trip: Checksum or CRC error</b>  |           |          |      |                       |                     |                |      |                              |             |                     |             |                     |             |                    |             |                   |      |                     |             |                |             |                      |             |                   |      |                              |      |   |
| 193                 | <p>Check the encoder signal for noise<br/>Check the encoder cable shielding<br/>With EnDat encoders, check the comms resolution and/or carry out the auto-configuration Pr 3.41</p>   |           |          |      |                       |                     |                |      |                              |             |                     |             |                     |             |                    |             |                   |      |                     |             |                |             |                      |             |                   |      |                              |      |   |
| <b>Enc6</b>         | <b>Drive encoder trip: Encoder has indicated an error</b>   |           |          |      |                       |                     |                |      |                              |             |                     |             |                     |             |                    |             |                   |      |                     |             |                |             |                      |             |                   |      |                              |      |   |
| 194                 | <p>Replace feedback device<br/>With SSI encoders, check the wiring and encoder supply setting</p>   |           |          |      |                       |                     |                |      |                              |             |                     |             |                     |             |                    |             |                   |      |                     |             |                |             |                      |             |                   |      |                              |      |   |

| Trip          | Diagnosis   |
|---------------|---|
| <b>Enc7</b>   | <b>Drive encoder trip: Initialisation failed</b>  |
| 195           | Re-set the drive<br>Check the correct encoder type is entered into Pr 3.38<br>Check encoder wiring<br>Check encoder power supply is set correctly<br>Carry out the auto-configuration Pr 3.41<br>Replace feedback device  |
| <b>Enc8</b>   | <b>Drive encoder trip: Auto configuration on power up has been requested and failed</b>   |
| 196           | Change the setting of Pr 3.41 to 0 and manually enter the drive encoder turns (Pr 3.33) and the equivalent number of lines per revolution (Pr 3.34)<br>Check the comms resolution   |
| <b>Enc9</b>   | <b>Drive encoder trip: Position feedback selected is selected from a Solutions Module slot which does not have a speed / position feedback Solutions Module fitted</b>  |
| 197           | Check setting of Pr 3.26 (or Pr 21.21 if the second motor parameters have been enabled)   |
| <b>Enc10</b>  | <b>Drive encoder trip: Servo mode phasing failure because encoder phase angle (Pr 3.25 or Pr 21.20) is incorrect</b>  |
| 198           | Check the encoder wiring.<br>Perform an autotune to measure the encoder phase angle or manually enter the correct phase angle into Pr 3.25 (or Pr 21.20).<br>Spurious Enc10 trips can be seen in very dynamic applications. This trip can be disabled by setting the overspeed threshold in Pr 3.08 to a value greater than zero. Caution should be used in setting the over speed threshold level as a value which is too large may mean that an encoder fault will not be detected. |
| <b>Enc11</b>  | <b>Drive encoder trip: A failure has occurred during the alignment of the analogue signals of a SINCOS encoder with the digital count derived from the sine and cosine waveforms and the comms position (if applicable). This fault is usually due to noise on the sine and cosine signals.</b>   |
| 161           | Check encoder cable shield.<br>Examine sine and cosine signals for noise.   |
| <b>Enc12</b>  | <b>Drive encoder trip: Hiperface encoder - The encoder type could not be identified during auto-configuration</b>   |
| 162           | Check encoder type can be auto-configured.<br>Check encoder wiring.<br>Enter parameters manually.   |
| <b>Enc13</b>  | <b>Drive encoder trip: EnDat encoder - The number of encoder turns read from the encoder during auto-configuration is not a power of 2</b>  |
| 163           | Select a different type of encoder.   |
| <b>Enc14</b>  | <b>Drive encoder trip: EnDat encoder - The number of comms bits defining the encoder position within a turn read from the encoder during auto-configuration is too large.</b>   |
| 164           | Select a different type of encoder.<br>Faulty encoder.  |
| <b>Enc15</b>  | <b>Drive encoder trip: The number of periods per revolution calculated from encoder data during auto-configuration is either less than 2 or greater than 50,000.</b>  |
| 165           | Linear motor pole pitch / encoder ppr set up is incorrect or out of parameter range<br>i.e. Pr 5.36 = 0 or Pr 21.31 = 0.<br>Faulty encoder.   |
| <b>Enc16</b>  | <b>Drive encoder trip: EnDat encoder - The number of comms bits per period for a linear encoder exceeds 255.</b>  |
| 166           | Select a different type of encoder.<br>Faulty encoder.  |
| <b>Enc17</b>  | <b>Drive encoder trip: The periods per revolution obtained during auto-configuration for a rotary SINCOS encoder is not a power of two.</b>   |
| 167           | Select a different type of encoder.<br>Faulty encoder.  |
| <b>ENP.Er</b> | <b>Data error from electronic nameplate stored in selected position feedback device</b>   |
| 176           | Replace feedback device   |
| <b>Et</b>     | <b>External trip from input on terminal 31</b>  |
| 6             | Check terminal 31 signal<br>Check value of Pr 10.32<br>Enter 12001 in Pr xx.00 and check for parameter controlling Pr 10.32<br>Ensure Pr 10.32 or Pr 10.38 (=6) are not being controlled by serial comms  |
| <b>HF01</b>   | <b>Data processing error: CPU address error</b>   |
|               | Hardware fault - return drive to supplier   |

| Trip        | Diagnosis  |
|-------------|--|
| <b>HF02</b> | <b>Data processing error: DMAC address error</b>   |
|             | Hardware fault - return drive to supplier  |
| <b>HF03</b> | <b>Data processing error: Illegal instruction</b>  |
|             | Hardware fault - return drive to supplier  |
| <b>HF04</b> | <b>Data processing error: Illegal slot instruction</b>   |
|             | Hardware fault - return drive to supplier  |
| <b>HF05</b> | <b>Data processing error: Undefined exception</b>  |
|             | Hardware fault - return drive to supplier  |
| <b>HF06</b> | <b>Data processing error: Reserved exception</b>   |
|             | Hardware fault - return drive to supplier  |
| <b>HF07</b> | <b>Data processing error: Watchdog failure</b>   |
|             | Hardware fault - return drive to supplier  |
| <b>HF08</b> | <b>Data processing error: Level 4 crash</b>  |
|             | Hardware fault - return drive to supplier  |
| <b>HF09</b> | <b>Data processing error: Heap overflow</b>  |
|             | Hardware fault - return drive to supplier  |
| <b>HF10</b> | <b>Data processing error: Router error</b>   |
|             | Hardware fault - return drive to supplier  |
| <b>HF11</b> | <b>Data processing error: Access to EEPROM failed</b>  |
|             | Hardware fault - return drive to supplier  |
| <b>HF12</b> | <b>Data processing error: Main program stack overflow</b>  |
|             | Hardware fault - return drive to supplier  |
| <b>HF13</b> | <b>Data processing error: Software incompatible with hardware</b>  |
|             | Hardware or software fault - return drive to supplier  |
| <b>HF17</b> | <b>Multi-module system thermistor short circuit</b>  |
| <b>217</b>  | Hardware fault - return drive to supplier  |
| <b>HF18</b> | <b>Multi-module system interconnect cable error</b>  |
| <b>218</b>  | Hardware fault - return drive to supplier  |
| <b>HF19</b> | <b>Temperature feedback multiplexing failure</b>   |
| <b>219</b>  | Hardware fault - return drive to supplier  |
| <b>HF20</b> | <b>Power stage recognition: serial code error</b>  |
| <b>220</b>  | Hardware fault - return drive to supplier  |
| <b>HF21</b> | <b>Power stage recognition: unrecognised frame size</b>  |
| <b>221</b>  | Hardware fault - return drive to supplier  |
| <b>HF22</b> | <b>Power stage recognition: multi module frame size mismatch</b>   |
| <b>222</b>  | Hardware fault - return drive to supplier  |
| <b>HF23</b> | <b>Power stage recognition: multi module voltage rating mismatch</b>   |
| <b>223</b>  | Hardware fault - return drive to supplier  |
| <b>HF24</b> | <b>Power stage recognition: unrecognised drive size</b>  |
| <b>224</b>  | Hardware fault - return drive to supplier  |
| <b>HF25</b> | <b>Current feedback offset error</b>   |
| <b>225</b>  | Hardware fault - return drive to supplier  |
| <b>HF26</b> | <b>Soft start relay failed to close, soft start monitor failed or braking IGBT short circuit at power up</b> |
| <b>226</b>  | Hardware fault - return drive to supplier  |
| <b>HF27</b> | <b>Power stage thermistor 1 fault</b>  |
| <b>227</b>  | Hardware fault - return drive to supplier  |

| Trip          | Diagnosis  |
|---------------|--|
| <b>HF28</b>   | <b>Power stage thermistor 2 fault or internal fan fault (size 3 and larger)</b>  |
| 228           | Hardware fault - return drive to supplier  |
| <b>HF29</b>   | <b>Control board thermistor fault</b>  |
| 229           | Hardware fault - return drive to supplier  |
| <b>HF30</b>   | <b>DCCT wire break trip from power module</b>  |
| 230           | Hardware fault - return drive to supplier  |
| <b>HF31</b>   | <b>Aux fan failure from power module</b>   |
| 231           | Replace auxiliary fan  |
| <b>HF32</b>   | <b>Power stage - a module has not powered up in a multi-module parallel drive</b>  |
| 232           | Check AC power supply  |
| <b>It.AC</b>  | <b>Output current overload timed out (<math>I^2t</math>) - accumulator value can be seen in Pr 4.19</b>  |
| 20            | Ensure the load is not jammed / sticking<br>Check the load on the motor has not changed<br>If seen during an autotune in servo mode, ensure that the motor rated current Pr <b>0.46</b> (Pr <b>5.07</b> ) or Pr <b>21.07</b> is $\leq$ Heavy Duty current rating of the drive<br>Tune the rated speed parameter (closed loop vector only)<br>Check feedback device signal for noise<br>Check the feedback device mechanical coupling |
| <b>It.br</b>  | <b>Braking resistor overload timed out (<math>I^2t</math>) – accumulator value can be seen in Pr 10.39</b>   |
| 19            | Ensure the values entered in Pr <b>10.30</b> and Pr <b>10.31</b> are correct<br>Increase the power rating of the braking resistor and change Pr <b>10.30</b> and Pr <b>10.31</b><br>If an external thermal protection device is being used and the braking resistor software overload is not required, set Pr <b>10.30</b> or Pr <b>10.31</b> to 0 to disable the trip   |
| <b>L.SYnC</b> | <b>Drive failed to synchronise to the supply voltage in Regen mode</b>   |
| 39            | Refer to the <i>Diagnostics</i> chapter in the <i>Unidrive SP Regen Installation Guide</i> .   |
| <b>O.CtL</b>  | <b>Drive control board over temperature</b>  |
| 23            | Check cubicle / drive fans are still functioning correctly<br>Check cubicle ventilation paths<br>Check cubicle door filters<br>Check ambient temperature<br>Reduce drive switching frequency   |
| <b>O.ht1</b>  | <b>Power device over temperature based on thermal model</b>  |
| 21            | Reduce drive switching frequency<br>Reduce duty cycle<br>Decrease acceleration / deceleration rates<br>Reduce motor load   |
| <b>O.ht2</b>  | <b>Heatsink over temperature</b>   |
| 22            | Check cubicle / drive fans are still functioning correctly<br>Check cubicle ventilation paths<br>Check cubicle door filters<br>Increase ventilation<br>Decrease acceleration / deceleration rates<br>Reduce drive switching frequency<br>Reduce duty cycle<br>Reduce motor load  |
| <b>Oht2.P</b> | <b>Power module heatsink over temperature</b>  |
| 105           | Check cubicle / drive fans are still functioning correctly<br>Check cubicle ventilation paths<br>Check cubicle door filters<br>Increase ventilation<br>Decrease acceleration / deceleration rates<br>Reduce drive switching frequency<br>Reduce duty cycle<br>Reduce motor load  |

| Trip          | Diagnosis   |
|---------------|---|
| <b>O.ht3</b>  | <b>Drive over-temperature based on thermal model</b>  |
| 27            | The drive will attempt to stop the motor before tripping. If the motor does not stop in 10s the drive trips immediately.<br>Check cubicle / drive fans are still functioning correctly<br>Check cubicle ventilation paths<br>Check cubicle door filters<br>Increase ventilation<br>Decrease acceleration / deceleration rates<br>Reduce duty cycle<br>Reduce motor load   |
| <b>Oht4.P</b> | <b>Power module rectifier over temperature or input snubber resistor over temperature (size 4 and above)</b>  |
| 102           | Check for supply imbalance<br>Check for supply disturbance such as notching from a DC drive<br>Check cubicle / drive fans are still functioning correctly<br>Check cubicle ventilation paths<br>Check cubicle door filters<br>Increase ventilation<br>Decrease acceleration / deceleration rates<br>Reduce drive switching frequency<br>Reduce duty cycle<br>Reduce motor load  |
| <b>OI.AC</b>  | <b>Instantaneous output over current detected: peak output current greater than 225%</b>  |
| 3             | Acceleration /deceleration rate is too short.<br>If seen during autotune reduce voltage boost Pr <b>5.15</b><br>Check for short circuit on output cabling<br>Check integrity of motor insulation<br>Check feedback device wiring<br>Check feedback device mechanical coupling<br>Check feedback signals are free from noise<br>Is motor cable length within limits for that frame size?<br>Reduce the values in speed loop gain parameters – Pr <b>3.10</b> , Pr <b>3.11</b> and Pr <b>3.12</b> (closed loop vector and servo modes only)<br>Has offset measurement test been completed? (servo mode only)<br>Reduce the values in current loop gain parameters - Pr <b>4.13</b> and Pr <b>4.14</b> (closed loop vector and servo modes only) |
| <b>OIAC.P</b> | <b>Power module over current detected from the module output currents</b>   |
| 104           | Acceleration /deceleration rate is too short.<br>If seen during autotune reduce voltage boost Pr <b>5.15</b><br>Check for short circuit on output cabling<br>Check integrity of motor insulation<br>Check feedback device wiring<br>Check feedback device mechanical coupling<br>Check feedback signals are free from noise<br>Is motor cable length within limits for that frame size?<br>Reduce the values in speed loop gain parameters – Pr <b>3.10</b> , Pr <b>3.11</b> and Pr <b>3.12</b> (closed loop vector and servo modes only)<br>Has offset measurement test been completed? (servo mode only)<br>Reduce the values in current loop gain parameters - Pr <b>4.13</b> and Pr <b>4.14</b> (closed loop vector and servo modes only) |
| <b>OI.br</b>  | <b>Braking transistor over-current detected: short circuit protection for the braking transistor activated</b>  |
| 4             | Check braking resistor wiring<br>Check braking resistor value is greater than or equal to the minimum resistance value<br>Check braking resistor insulation   |
| <b>OIbr.P</b> | <b>Power module braking IGBT over current</b>   |
| 103           | Check braking resistor wiring<br>Check braking resistor value is greater than or equal to the minimum resistance value<br>Check braking resistor insulation   |
| <b>OldC.P</b> | <b>Power module over current detected from IGBT on state voltage monitoring</b>   |
| 109           | Vce IGBT protection activated.<br>Check motor and cable insulation.   |
| <b>O.Ld1</b>  | <b>Digital output overload: total current drawn from 24V supply and digital outputs exceeds 200mA</b>   |
| 26            | Check total load on digital outputs (terminals 24,25,26)and +24V rail (terminal 22)   |
| <b>O.SPd</b>  | <b>Motor speed has exceeded the over speed threshold</b>  |
| 7             | Increase the over speed trip threshold in Pr <b>3.08</b> (closed loop modes only)<br>Speed has exceeded 1.2 x Pr <b>1.06</b> or Pr <b>1.07</b> (open loop mode)<br>Reduce the speed loop P gain (Pr <b>3.10</b> ) to reduce the speed overshoot (closed loop modes only)  |

| Trip                 | Diagnosis   |  |              |  |     |     |     |     |     |     |     |     |     |     |      |      |
|----------------------|---|--|--------------|--|-----|-----|-----|-----|-----|-----|-----|-----|-----|-----|------|------|
| <b>OV</b>            | <b>DC bus voltage has exceeded the peak level or the maximum continuous level for 15 seconds</b>  |  |              |  |     |     |     |     |     |     |     |     |     |     |      |      |
| 2                    | <p>Increase deceleration ramp (Pr <b>0.04</b>)<br/> Decrease braking resistor value (staying above the minimum value)<br/> Check nominal AC supply level<br/> Check for supply disturbances which could cause the DC bus to rise – voltage overshoot after supply recovery from a notch induced by DC drives.<br/> Check motor insulation</p> <table border="1"> <thead> <tr> <th>Drive voltage rating</th> <th>Peak voltage</th> <th>Maximum continuous voltage level (15s)</th> </tr> </thead> <tbody> <tr> <td>200</td> <td>415</td> <td>410</td> </tr> <tr> <td>400</td> <td>830</td> <td>815</td> </tr> <tr> <td>575</td> <td>990</td> <td>970</td> </tr> <tr> <td>690</td> <td>1190</td> <td>1175</td> </tr> </tbody> </table> <p>If the drive is operating in low voltage DC mode the overvoltage trip level is 1.45 x Pr <b>6.46</b>.</p> | Drive voltage rating                   | Peak voltage | Maximum continuous voltage level (15s) | 200 | 415 | 410 | 400 | 830 | 815 | 575 | 990 | 970 | 690 | 1190 | 1175 |
| Drive voltage rating | Peak voltage  | Maximum continuous voltage level (15s) |              |  |     |     |     |     |     |     |     |     |     |     |      |      |
| 200                  | 415   | 410                                    |              |  |     |     |     |     |     |     |     |     |     |     |      |      |
| 400                  | 830   | 815                                    |              |  |     |     |     |     |     |     |     |     |     |     |      |      |
| 575                  | 990   | 970                                    |              |  |     |     |     |     |     |     |     |     |     |     |      |      |
| 690                  | 1190  | 1175                                   |              |  |     |     |     |     |     |     |     |     |     |     |      |      |
| <b>OV.P</b>          | <b>Power module DC bus voltage has exceeded the peak level or the maximum continuous level for 15 seconds</b>   |  |              |  |     |     |     |     |     |     |     |     |     |     |      |      |
| 106                  | <p>Increase deceleration ramp (Pr <b>0.04</b>)<br/> Decrease braking resistor value (staying above the minimum value)<br/> Check nominal AC supply level<br/> Check for supply disturbances which could cause the DC bus to rise – voltage overshoot after supply recovery from a notch induced by DC drives.<br/> Check motor insulation</p> <table border="1"> <thead> <tr> <th>Drive voltage rating</th> <th>Peak voltage</th> <th>Maximum continuous voltage level (15s)</th> </tr> </thead> <tbody> <tr> <td>200</td> <td>415</td> <td>410</td> </tr> <tr> <td>400</td> <td>830</td> <td>815</td> </tr> <tr> <td>575</td> <td>990</td> <td>970</td> </tr> <tr> <td>690</td> <td>1190</td> <td>1175</td> </tr> </tbody> </table> <p>If the drive is operating in low voltage DC mode the overvoltage trip level is 1.45 x Pr <b>6.46</b>.</p> | Drive voltage rating                   | Peak voltage | Maximum continuous voltage level (15s) | 200 | 415 | 410 | 400 | 830 | 815 | 575 | 990 | 970 | 690 | 1190 | 1175 |
| Drive voltage rating | Peak voltage  | Maximum continuous voltage level (15s) |              |  |     |     |     |     |     |     |     |     |     |     |      |      |
| 200                  | 415   | 410                                    |              |  |     |     |     |     |     |     |     |     |     |     |      |      |
| 400                  | 830   | 815                                    |              |  |     |     |     |     |     |     |     |     |     |     |      |      |
| 575                  | 990   | 970                                    |              |  |     |     |     |     |     |     |     |     |     |     |      |      |
| 690                  | 1190  | 1175                                   |              |  |     |     |     |     |     |     |     |     |     |     |      |      |
| <b>PAd</b>           | <b>Keypad has been removed when the drive is receiving the speed reference from the keypad</b>  |  |              |  |     |     |     |     |     |     |     |     |     |     |      |      |
| 34                   | <p>Fit keypad and reset<br/> Change speed reference selector to select speed reference from another source</p>  |  |              |  |     |     |     |     |     |     |     |     |     |     |      |      |
| <b>Ph</b>            | <b>AC voltage input phase loss or large supply imbalance detected</b>   |  |              |  |     |     |     |     |     |     |     |     |     |     |      |      |
| 32                   | <p>Ensure all three phases are present and balanced<br/> Check input voltage levels are correct (at full load)</p> <p><b>NOTE</b></p> <p>Load level must be between 50 and 100% for the drive to trip under phase loss conditions. The drive will attempt to stop the motor before this trip is initiated.</p>  |  |              |  |     |     |     |     |     |     |     |     |     |     |      |      |
| <b>Ph.P</b>          | <b>Power module phase loss detection</b>  |  |              |  |     |     |     |     |     |     |     |     |     |     |      |      |
| 107                  | <p>Ensure all three phases are present and balanced<br/> Check input voltage levels are correct (at full load)</p>  |  |              |  |     |     |     |     |     |     |     |     |     |     |      |      |
| <b>PS</b>            | <b>Internal power supply fault</b>  |  |              |  |     |     |     |     |     |     |     |     |     |     |      |      |
| 5                    | <p>Remove any Solutions Modules and reset<br/> Check integrity of interface ribbon cables and connections (size 4,5,6 only)<br/> Hardware fault - return drive to supplier</p>  |  |              |  |     |     |     |     |     |     |     |     |     |     |      |      |
| <b>PS.10V</b>        | <b>10V user power supply current greater than 10mA</b>  |  |              |  |     |     |     |     |     |     |     |     |     |     |      |      |
| 8                    | <p>Check wiring to terminal 4<br/> Reduce load on terminal 4</p>  |  |              |  |     |     |     |     |     |     |     |     |     |     |      |      |
| <b>PS.24V</b>        | <b>24V internal power supply overload</b>   |  |              |  |     |     |     |     |     |     |     |     |     |     |      |      |
| 9                    | <p>The total user load of the drive and Solutions Modules has exceeded the internal 24V power supply limit.<br/> The user load consists of the drive's digital outputs, the SM-I/O Plus digital outputs, the drive's main encoder supply and the SM-Universal Encoder Plus encoder supply.</p> <ul style="list-style-type: none"> <li>Reduce load and reset</li> <li>Provide an external 24V &gt;50W power supply</li> <li>Remove any Solutions Modules and reset</li> </ul>  |  |              |  |     |     |     |     |     |     |     |     |     |     |      |      |
| <b>PS.P</b>          | <b>Power module power supply fail</b>   |  |              |  |     |     |     |     |     |     |     |     |     |     |      |      |
| 108                  | <p>Remove any Solutions Modules and reset<br/> Check integrity of interface ribbon cables and connections (size 4,5,6 only)<br/> Hardware fault - return drive to supplier</p>  |  |              |  |     |     |     |     |     |     |     |     |     |     |      |      |
| <b>PSAVE.Er</b>      | <b>Power down save parameters in the EEPROM are corrupt</b>   |  |              |  |     |     |     |     |     |     |     |     |     |     |      |      |
| 37                   | <p>Indicates that the power was removed when power down save parameters were being saved.<br/> The drive will revert back to the power down parameter set that was last saved successfully.<br/> Perform a user save (Pr <b>xx.00</b> to 1000 or 1001 and reset the drive) or power down the drive normally to ensure this trip does or occur the next time the drive is powered up.</p>  |  |              |  |     |     |     |     |     |     |     |     |     |     |      |      |

| <b>Trip</b>        | <b>Diagnosis</b>  |
|--------------------|---|
| <b>rS</b>          | <b>Failure to measure resistance during autotune or when starting in open loop vector mode 0 or 3</b>   |
| <b>33</b>          | Check motor power connection continuity   |
| <b>SAVE.Er</b>     | <b>User save parameters in the EEPROM are corrupt</b>   |
| <b>36</b>          | Indicates that the power was removed when user parameters were being saved. The drive will revert back to the user parameter set that was last saved successfully. Perform a user save (Pr <b>xx.00</b> to 1000 or 1001 and reset the drive) to ensure this trip does or occur the next time the drive is powered up. |
| <b>SCL</b>         | <b>Drive RS485 serial comms loss to remote keypad</b>   |
| <b>30</b>          | Refit the cable between the drive and keypad<br>Check cable for damage<br>Replace cable<br>Replace keypad   |
| <b>SLX.dF</b>      | <b>Solutions Module slot X trip: Solutions Module type fitted in slot X changed</b>   |
| <b>204,209,214</b> | Save parameters and reset   |

| Trip          | Diagnosis  |  |  |  |
|---------------|--|--|--|--|
| <b>SLX.Er</b> | <b>Solutions Module slot X trip: Solutions Module in slot X has detected a fault</b>   |  |  |  |
| 202,207,212   | <b>Feedback module category</b>  |  |  |  |
|               | Check value in Pr <b>15/16/17.50</b> . The following table lists the possible error codes for the SM-Universal Encoder Plus, SM-Encoder Plus and SM-Resolver. See the <i>Diagnostics</i> section in the relevant Solutions Module User Guide for more information. |  |  |  |
|               | Error code   | Module   | Trip Description   | Diagnostic   |
|               | 0  | All  | No trip  | No fault detected  |
|               | 1  | SM-Universal Encoder Plus  | Encoder power supply overload  | Check encoder power supply wiring and encoder current requirement Maximum current = 200mA @ 15V, or 300mA @ 8V and 5V  |
|               |  | SM-Resolver  | Excitation output short circuit  | Check the excitation output wiring.  |
|               | 2  | SM-Universal Encoder Plus & SM-Resolver  | Wire break   | Check cable continuity<br>Check wiring of feedback signals is correct<br>Check supply voltage or excitation output level<br>Replace feedback device                                    |
|               | 3  | SM-Universal Encoder Plus  | Phase offset incorrect whilst running  | Check the encoder signal for noise<br>Check encoder shielding<br>Check the integrity of the encoder mechanical mounting<br>Repeat the offset measurement test                          |
|               | 4  | SM-Universal Encoder Plus  | Feedback device communications failure   | Ensure encoder power supply is correct<br>Ensure baud rate is correct<br>Check encoder wiring<br>Replace feedback device   |
|               | 5  | SM-Universal Encoder Plus  | Checksum or CRC error  | Check the encoder signal for noise<br>Check the encoder cable shielding  |
|               | 6  | SM-Universal Encoder Plus  | Encoder has indicated an error   | Replace encoder  |
|               | 7  | SM-Universal Encoder Plus  | Initialisation failed  | Check the correct encoder type is entered into Pr <b>15/16/17.15</b><br>Check encoder wiring<br>Check supply voltage level<br>Replace feedback device                                  |
|               | 8  | SM-Universal Encoder Plus  | Auto configuration on power up has been requested and failed   | Change the setting of Pr <b>15/16/17.18</b> and manually enter the number of turns (Pr <b>15/16/17.09</b> ) and the equivalent number of lines per revolution (Pr <b>15/16/17.10</b> ) |
|               | 9  | SM-Universal Encoder Plus  | Motor thermistor trip  | Check motor temperature<br>Check thermistor continuity   |
|               | 10   | SM-Universal Encoder Plus  | Motor thermistor short circuit   | Check motor thermistor wiring<br>Replace motor / motor thermistor  |
|               | 11   | SM-Universal Encoder Plus  | Failure of the sincos analogue position alignment during encoder initialisation  | Check encoder cable shield.<br>Examine sine and cosine signals for noise.  |
|               |  | SM-Resolver  | Poles not compatible with motor  | Check that the correct number of resolver poles has been set in Pr <b>15/16/17.15</b> .  |
|               | 12   | SM-Universal Encoder Plus  | Encoder type could not be identified during auto-configuration   | Check encoder type can be auto-configured.<br>Check encoder wiring.<br>Enter parameters manually.  |
|               | 13   | SM-Universal Encoder Plus  | Number of encoder turns read from the encoder during auto-configuration is not a power of 2  | Select a different type of encoder.  |
|               | 14   | SM-Universal Encoder Plus  | Number of comms bits defining the encoder position within a turn read from the encoder during auto-configuration is too large.                         | Select a different type of encoder.<br>Faulty encoder.   |
| 15            | SM-Universal Encoder Plus  | The number of periods per revolution calculated from encoder data during auto-configuration is either <2 or >50,000. | Linear motor pole pitch / encoder ppr set up is incorrect or out of parameter range i.e. Pr <b>5.36</b> = 0 or Pr <b>21.31</b> = 0.<br>Faulty encoder. |  |
| 16            | SM-Universal Encoder Plus  | The number of comms bits per period for a linear encoder exceeds 255.  | Select a different type of encoder.<br>Faulty encoder.   |  |
| 74            | All  | Solutions Module has overheated  | Check ambient temperature<br>Check cubicle ventilation   |  |

| Trip               | Diagnosis  |   |                  |    |                             |    |   |    |                          |    |   |    |   |    |                              |    |                               |    |        |    |   |    |                        |    |                             |    |  |    |                          |    |                        |    |                                      |    |                  |    |        |    |                                  |    |                               |    |                           |    |  |    |  |    |                             |    |                         |    |                       |    |                         |    |                                     |    |                     |    |   |    |  |    |   |    |   |    |                             |    |                                |    |                                       |    |                  |    |                      |    |   |    |   |    |   |    |   |    |  |    |                    |    |                               |
|--------------------|--|---|------------------|----|-----------------------------|----|---|----|--------------------------|----|---|----|---|----|------------------------------|----|-------------------------------|----|--------|----|---|----|------------------------|----|-----------------------------|----|--|----|--------------------------|----|------------------------|----|--------------------------------------|----|------------------|----|--------|----|----------------------------------|----|-------------------------------|----|---------------------------|----|--|----|--|----|-----------------------------|----|-------------------------|----|-----------------------|----|-------------------------|----|-------------------------------------|----|---------------------|----|---|----|--|----|---|----|---|----|-----------------------------|----|--------------------------------|----|---------------------------------------|----|------------------|----|----------------------|----|---|----|---|----|---|----|---|----|--|----|--------------------|----|-------------------------------|
| <b>SLX.Er</b>      | <b>Solutions Module slot X trip: Solutions Module in slot X has detected a fault</b>   |   |                  |    |                             |    |   |    |                          |    |   |    |   |    |                              |    |                               |    |        |    |   |    |                        |    |                             |    |  |    |                          |    |                        |    |                                      |    |                  |    |        |    |                                  |    |                               |    |                           |    |  |    |  |    |                             |    |                         |    |                       |    |                         |    |                                     |    |                     |    |   |    |  |    |   |    |   |    |                             |    |                                |    |                                       |    |                  |    |                      |    |   |    |   |    |   |    |   |    |  |    |                    |    |                               |
| <b>202,207,212</b> | <p><b>Automation (Applications) module category</b></p> <p>Check value in Pr <b>15/16/17.50</b>. The following table lists the possible error codes for the SM-Applications and SM-Applications Lite. See the <i>Diagnostics</i> section in the relevant Solutions Module User Guide for more information.</p> <table border="1"> <thead> <tr> <th style="text-align: center;">Error Code</th> <th style="text-align: center;">Trip Description</th> </tr> </thead> <tbody> <tr><td>39</td><td>User program stack overflow</td></tr> <tr><td>40</td><td>Unknown error - please contact supplier</td></tr> <tr><td>41</td><td>Parameter does not exist</td></tr> <tr><td>42</td><td>Attempt to write to a read-only parameter</td></tr> <tr><td>43</td><td>Attempt to read from a write-only parameter</td></tr> <tr><td>44</td><td>Parameter value out of range</td></tr> <tr><td>45</td><td>Invalid synchronisation modes</td></tr> <tr><td>46</td><td>Unused</td></tr> <tr><td>47</td><td>Synchronisation lost with CTSync Master</td></tr> <tr><td>48</td><td>RS485 not in user mode</td></tr> <tr><td>49</td><td>Invalid RS485 configuration</td></tr> <tr><td>50</td><td>Maths error - divide by zero or overflow</td></tr> <tr><td>51</td><td>Array index out of range</td></tr> <tr><td>52</td><td>Control word user trip</td></tr> <tr><td>53</td><td>DPL program incompatible with target</td></tr> <tr><td>54</td><td>DPL task overrun</td></tr> <tr><td>55</td><td>Unused</td></tr> <tr><td>56</td><td>Invalid timer unit configuration</td></tr> <tr><td>57</td><td>Function block does not exist</td></tr> <tr><td>58</td><td>Flash PLC Storage corrupt</td></tr> <tr><td>59</td><td>Drive rejected application module as Sync master</td></tr> <tr><td>60</td><td>CTNet hardware failure. Please contact your supplier</td></tr> <tr><td>61</td><td>CTNet invalid configuration</td></tr> <tr><td>62</td><td>CTNet invalid baud-rate</td></tr> <tr><td>63</td><td>CTNet invalid node ID</td></tr> <tr><td>64</td><td>Digital Output overload</td></tr> <tr><td>65</td><td>Invalid function block parameter(s)</td></tr> <tr><td>66</td><td>User heap too large</td></tr> <tr><td>67</td><td>RAM file does not exist or a non-RAM file id has been specified</td></tr> <tr><td>68</td><td>The RAM file specified is not associated to an array</td></tr> <tr><td>69</td><td>Failed to update drive parameter database cache in Flash memory</td></tr> <tr><td>70</td><td>User program downloaded while drive enabled</td></tr> <tr><td>71</td><td>Failed to change drive mode</td></tr> <tr><td>72</td><td>Invalid CTNet buffer operation</td></tr> <tr><td>73</td><td>Fast parameter initialisation failure</td></tr> <tr><td>74</td><td>Over-temperature</td></tr> <tr><td>75</td><td>Hardware unavailable</td></tr> <tr><td>76</td><td>Module type cannot be resolved. Module is not recognised.</td></tr> <tr><td>77</td><td>Inter-option module comms error with module in slot 1</td></tr> <tr><td>78</td><td>Inter-option module comms error with module in slot 2</td></tr> <tr><td>79</td><td>Inter-option module comms error with module in slot 3</td></tr> <tr><td>80</td><td>Inter-option module comms error with module unknown slot</td></tr> <tr><td>81</td><td>APC internal error</td></tr> <tr><td>82</td><td>Communcations to drive faulty</td></tr> </tbody> </table> | Error Code  | Trip Description | 39 | User program stack overflow | 40 | Unknown error - please contact supplier | 41 | Parameter does not exist | 42 | Attempt to write to a read-only parameter | 43 | Attempt to read from a write-only parameter | 44 | Parameter value out of range | 45 | Invalid synchronisation modes | 46 | Unused | 47 | Synchronisation lost with CTSync Master | 48 | RS485 not in user mode | 49 | Invalid RS485 configuration | 50 | Maths error - divide by zero or overflow | 51 | Array index out of range | 52 | Control word user trip | 53 | DPL program incompatible with target | 54 | DPL task overrun | 55 | Unused | 56 | Invalid timer unit configuration | 57 | Function block does not exist | 58 | Flash PLC Storage corrupt | 59 | Drive rejected application module as Sync master | 60 | CTNet hardware failure. Please contact your supplier | 61 | CTNet invalid configuration | 62 | CTNet invalid baud-rate | 63 | CTNet invalid node ID | 64 | Digital Output overload | 65 | Invalid function block parameter(s) | 66 | User heap too large | 67 | RAM file does not exist or a non-RAM file id has been specified | 68 | The RAM file specified is not associated to an array | 69 | Failed to update drive parameter database cache in Flash memory | 70 | User program downloaded while drive enabled | 71 | Failed to change drive mode | 72 | Invalid CTNet buffer operation | 73 | Fast parameter initialisation failure | 74 | Over-temperature | 75 | Hardware unavailable | 76 | Module type cannot be resolved. Module is not recognised. | 77 | Inter-option module comms error with module in slot 1 | 78 | Inter-option module comms error with module in slot 2 | 79 | Inter-option module comms error with module in slot 3 | 80 | Inter-option module comms error with module unknown slot | 81 | APC internal error | 82 | Communcations to drive faulty |
|                    | Error Code   | Trip Description  |                  |    |                             |    |   |    |                          |    |   |    |   |    |                              |    |                               |    |        |    |   |    |                        |    |                             |    |  |    |                          |    |                        |    |                                      |    |                  |    |        |    |                                  |    |                               |    |                           |    |  |    |  |    |                             |    |                         |    |                       |    |                         |    |                                     |    |                     |    |   |    |  |    |   |    |   |    |                             |    |                                |    |                                       |    |                  |    |                      |    |   |    |   |    |   |    |   |    |  |    |                    |    |                               |
|                    | 39   | User program stack overflow                                     |                  |    |                             |    |   |    |                          |    |   |    |   |    |                              |    |                               |    |        |    |   |    |                        |    |                             |    |  |    |                          |    |                        |    |                                      |    |                  |    |        |    |                                  |    |                               |    |                           |    |  |    |  |    |                             |    |                         |    |                       |    |                         |    |                                     |    |                     |    |   |    |  |    |   |    |   |    |                             |    |                                |    |                                       |    |                  |    |                      |    |   |    |   |    |   |    |   |    |  |    |                    |    |                               |
|                    | 40   | Unknown error - please contact supplier                         |                  |    |                             |    |   |    |                          |    |   |    |   |    |                              |    |                               |    |        |    |   |    |                        |    |                             |    |  |    |                          |    |                        |    |                                      |    |                  |    |        |    |                                  |    |                               |    |                           |    |  |    |  |    |                             |    |                         |    |                       |    |                         |    |                                     |    |                     |    |   |    |  |    |   |    |   |    |                             |    |                                |    |                                       |    |                  |    |                      |    |   |    |   |    |   |    |   |    |  |    |                    |    |                               |
|                    | 41   | Parameter does not exist  |                  |    |                             |    |   |    |                          |    |   |    |   |    |                              |    |                               |    |        |    |   |    |                        |    |                             |    |  |    |                          |    |                        |    |                                      |    |                  |    |        |    |                                  |    |                               |    |                           |    |  |    |  |    |                             |    |                         |    |                       |    |                         |    |                                     |    |                     |    |   |    |  |    |   |    |   |    |                             |    |                                |    |                                       |    |                  |    |                      |    |   |    |   |    |   |    |   |    |  |    |                    |    |                               |
|                    | 42   | Attempt to write to a read-only parameter                       |                  |    |                             |    |   |    |                          |    |   |    |   |    |                              |    |                               |    |        |    |   |    |                        |    |                             |    |  |    |                          |    |                        |    |                                      |    |                  |    |        |    |                                  |    |                               |    |                           |    |  |    |  |    |                             |    |                         |    |                       |    |                         |    |                                     |    |                     |    |   |    |  |    |   |    |   |    |                             |    |                                |    |                                       |    |                  |    |                      |    |   |    |   |    |   |    |   |    |  |    |                    |    |                               |
|                    | 43   | Attempt to read from a write-only parameter                     |                  |    |                             |    |   |    |                          |    |   |    |   |    |                              |    |                               |    |        |    |   |    |                        |    |                             |    |  |    |                          |    |                        |    |                                      |    |                  |    |        |    |                                  |    |                               |    |                           |    |  |    |  |    |                             |    |                         |    |                       |    |                         |    |                                     |    |                     |    |   |    |  |    |   |    |   |    |                             |    |                                |    |                                       |    |                  |    |                      |    |   |    |   |    |   |    |   |    |  |    |                    |    |                               |
|                    | 44   | Parameter value out of range                                    |                  |    |                             |    |   |    |                          |    |   |    |   |    |                              |    |                               |    |        |    |   |    |                        |    |                             |    |  |    |                          |    |                        |    |                                      |    |                  |    |        |    |                                  |    |                               |    |                           |    |  |    |  |    |                             |    |                         |    |                       |    |                         |    |                                     |    |                     |    |   |    |  |    |   |    |   |    |                             |    |                                |    |                                       |    |                  |    |                      |    |   |    |   |    |   |    |   |    |  |    |                    |    |                               |
|                    | 45   | Invalid synchronisation modes                                   |                  |    |                             |    |   |    |                          |    |   |    |   |    |                              |    |                               |    |        |    |   |    |                        |    |                             |    |  |    |                          |    |                        |    |                                      |    |                  |    |        |    |                                  |    |                               |    |                           |    |  |    |  |    |                             |    |                         |    |                       |    |                         |    |                                     |    |                     |    |   |    |  |    |   |    |   |    |                             |    |                                |    |                                       |    |                  |    |                      |    |   |    |   |    |   |    |   |    |  |    |                    |    |                               |
|                    | 46   | Unused  |                  |    |                             |    |   |    |                          |    |   |    |   |    |                              |    |                               |    |        |    |   |    |                        |    |                             |    |  |    |                          |    |                        |    |                                      |    |                  |    |        |    |                                  |    |                               |    |                           |    |  |    |  |    |                             |    |                         |    |                       |    |                         |    |                                     |    |                     |    |   |    |  |    |   |    |   |    |                             |    |                                |    |                                       |    |                  |    |                      |    |   |    |   |    |   |    |   |    |  |    |                    |    |                               |
|                    | 47   | Synchronisation lost with CTSync Master                         |                  |    |                             |    |   |    |                          |    |   |    |   |    |                              |    |                               |    |        |    |   |    |                        |    |                             |    |  |    |                          |    |                        |    |                                      |    |                  |    |        |    |                                  |    |                               |    |                           |    |  |    |  |    |                             |    |                         |    |                       |    |                         |    |                                     |    |                     |    |   |    |  |    |   |    |   |    |                             |    |                                |    |                                       |    |                  |    |                      |    |   |    |   |    |   |    |   |    |  |    |                    |    |                               |
|                    | 48   | RS485 not in user mode  |                  |    |                             |    |   |    |                          |    |   |    |   |    |                              |    |                               |    |        |    |   |    |                        |    |                             |    |  |    |                          |    |                        |    |                                      |    |                  |    |        |    |                                  |    |                               |    |                           |    |  |    |  |    |                             |    |                         |    |                       |    |                         |    |                                     |    |                     |    |   |    |  |    |   |    |   |    |                             |    |                                |    |                                       |    |                  |    |                      |    |   |    |   |    |   |    |   |    |  |    |                    |    |                               |
|                    | 49   | Invalid RS485 configuration                                     |                  |    |                             |    |   |    |                          |    |   |    |   |    |                              |    |                               |    |        |    |   |    |                        |    |                             |    |  |    |                          |    |                        |    |                                      |    |                  |    |        |    |                                  |    |                               |    |                           |    |  |    |  |    |                             |    |                         |    |                       |    |                         |    |                                     |    |                     |    |   |    |  |    |   |    |   |    |                             |    |                                |    |                                       |    |                  |    |                      |    |   |    |   |    |   |    |   |    |  |    |                    |    |                               |
|                    | 50   | Maths error - divide by zero or overflow                        |                  |    |                             |    |   |    |                          |    |   |    |   |    |                              |    |                               |    |        |    |   |    |                        |    |                             |    |  |    |                          |    |                        |    |                                      |    |                  |    |        |    |                                  |    |                               |    |                           |    |  |    |  |    |                             |    |                         |    |                       |    |                         |    |                                     |    |                     |    |   |    |  |    |   |    |   |    |                             |    |                                |    |                                       |    |                  |    |                      |    |   |    |   |    |   |    |   |    |  |    |                    |    |                               |
|                    | 51   | Array index out of range  |                  |    |                             |    |   |    |                          |    |   |    |   |    |                              |    |                               |    |        |    |   |    |                        |    |                             |    |  |    |                          |    |                        |    |                                      |    |                  |    |        |    |                                  |    |                               |    |                           |    |  |    |  |    |                             |    |                         |    |                       |    |                         |    |                                     |    |                     |    |   |    |  |    |   |    |   |    |                             |    |                                |    |                                       |    |                  |    |                      |    |   |    |   |    |   |    |   |    |  |    |                    |    |                               |
|                    | 52   | Control word user trip  |                  |    |                             |    |   |    |                          |    |   |    |   |    |                              |    |                               |    |        |    |   |    |                        |    |                             |    |  |    |                          |    |                        |    |                                      |    |                  |    |        |    |                                  |    |                               |    |                           |    |  |    |  |    |                             |    |                         |    |                       |    |                         |    |                                     |    |                     |    |   |    |  |    |   |    |   |    |                             |    |                                |    |                                       |    |                  |    |                      |    |   |    |   |    |   |    |   |    |  |    |                    |    |                               |
|                    | 53   | DPL program incompatible with target                            |                  |    |                             |    |   |    |                          |    |   |    |   |    |                              |    |                               |    |        |    |   |    |                        |    |                             |    |  |    |                          |    |                        |    |                                      |    |                  |    |        |    |                                  |    |                               |    |                           |    |  |    |  |    |                             |    |                         |    |                       |    |                         |    |                                     |    |                     |    |   |    |  |    |   |    |   |    |                             |    |                                |    |                                       |    |                  |    |                      |    |   |    |   |    |   |    |   |    |  |    |                    |    |                               |
|                    | 54   | DPL task overrun  |                  |    |                             |    |   |    |                          |    |   |    |   |    |                              |    |                               |    |        |    |   |    |                        |    |                             |    |  |    |                          |    |                        |    |                                      |    |                  |    |        |    |                                  |    |                               |    |                           |    |  |    |  |    |                             |    |                         |    |                       |    |                         |    |                                     |    |                     |    |   |    |  |    |   |    |   |    |                             |    |                                |    |                                       |    |                  |    |                      |    |   |    |   |    |   |    |   |    |  |    |                    |    |                               |
|                    | 55   | Unused  |                  |    |                             |    |   |    |                          |    |   |    |   |    |                              |    |                               |    |        |    |   |    |                        |    |                             |    |  |    |                          |    |                        |    |                                      |    |                  |    |        |    |                                  |    |                               |    |                           |    |  |    |  |    |                             |    |                         |    |                       |    |                         |    |                                     |    |                     |    |   |    |  |    |   |    |   |    |                             |    |                                |    |                                       |    |                  |    |                      |    |   |    |   |    |   |    |   |    |  |    |                    |    |                               |
|                    | 56   | Invalid timer unit configuration                                |                  |    |                             |    |   |    |                          |    |   |    |   |    |                              |    |                               |    |        |    |   |    |                        |    |                             |    |  |    |                          |    |                        |    |                                      |    |                  |    |        |    |                                  |    |                               |    |                           |    |  |    |  |    |                             |    |                         |    |                       |    |                         |    |                                     |    |                     |    |   |    |  |    |   |    |   |    |                             |    |                                |    |                                       |    |                  |    |                      |    |   |    |   |    |   |    |   |    |  |    |                    |    |                               |
|                    | 57   | Function block does not exist                                   |                  |    |                             |    |   |    |                          |    |   |    |   |    |                              |    |                               |    |        |    |   |    |                        |    |                             |    |  |    |                          |    |                        |    |                                      |    |                  |    |        |    |                                  |    |                               |    |                           |    |  |    |  |    |                             |    |                         |    |                       |    |                         |    |                                     |    |                     |    |   |    |  |    |   |    |   |    |                             |    |                                |    |                                       |    |                  |    |                      |    |   |    |   |    |   |    |   |    |  |    |                    |    |                               |
|                    | 58   | Flash PLC Storage corrupt                                       |                  |    |                             |    |   |    |                          |    |   |    |   |    |                              |    |                               |    |        |    |   |    |                        |    |                             |    |  |    |                          |    |                        |    |                                      |    |                  |    |        |    |                                  |    |                               |    |                           |    |  |    |  |    |                             |    |                         |    |                       |    |                         |    |                                     |    |                     |    |   |    |  |    |   |    |   |    |                             |    |                                |    |                                       |    |                  |    |                      |    |   |    |   |    |   |    |   |    |  |    |                    |    |                               |
|                    | 59   | Drive rejected application module as Sync master                |                  |    |                             |    |   |    |                          |    |   |    |   |    |                              |    |                               |    |        |    |   |    |                        |    |                             |    |  |    |                          |    |                        |    |                                      |    |                  |    |        |    |                                  |    |                               |    |                           |    |  |    |  |    |                             |    |                         |    |                       |    |                         |    |                                     |    |                     |    |   |    |  |    |   |    |   |    |                             |    |                                |    |                                       |    |                  |    |                      |    |   |    |   |    |   |    |   |    |  |    |                    |    |                               |
|                    | 60   | CTNet hardware failure. Please contact your supplier            |                  |    |                             |    |   |    |                          |    |   |    |   |    |                              |    |                               |    |        |    |   |    |                        |    |                             |    |  |    |                          |    |                        |    |                                      |    |                  |    |        |    |                                  |    |                               |    |                           |    |  |    |  |    |                             |    |                         |    |                       |    |                         |    |                                     |    |                     |    |   |    |  |    |   |    |   |    |                             |    |                                |    |                                       |    |                  |    |                      |    |   |    |   |    |   |    |   |    |  |    |                    |    |                               |
|                    | 61   | CTNet invalid configuration                                     |                  |    |                             |    |   |    |                          |    |   |    |   |    |                              |    |                               |    |        |    |   |    |                        |    |                             |    |  |    |                          |    |                        |    |                                      |    |                  |    |        |    |                                  |    |                               |    |                           |    |  |    |  |    |                             |    |                         |    |                       |    |                         |    |                                     |    |                     |    |   |    |  |    |   |    |   |    |                             |    |                                |    |                                       |    |                  |    |                      |    |   |    |   |    |   |    |   |    |  |    |                    |    |                               |
|                    | 62   | CTNet invalid baud-rate   |                  |    |                             |    |   |    |                          |    |   |    |   |    |                              |    |                               |    |        |    |   |    |                        |    |                             |    |  |    |                          |    |                        |    |                                      |    |                  |    |        |    |                                  |    |                               |    |                           |    |  |    |  |    |                             |    |                         |    |                       |    |                         |    |                                     |    |                     |    |   |    |  |    |   |    |   |    |                             |    |                                |    |                                       |    |                  |    |                      |    |   |    |   |    |   |    |   |    |  |    |                    |    |                               |
|                    | 63   | CTNet invalid node ID   |                  |    |                             |    |   |    |                          |    |   |    |   |    |                              |    |                               |    |        |    |   |    |                        |    |                             |    |  |    |                          |    |                        |    |                                      |    |                  |    |        |    |                                  |    |                               |    |                           |    |  |    |  |    |                             |    |                         |    |                       |    |                         |    |                                     |    |                     |    |   |    |  |    |   |    |   |    |                             |    |                                |    |                                       |    |                  |    |                      |    |   |    |   |    |   |    |   |    |  |    |                    |    |                               |
|                    | 64   | Digital Output overload   |                  |    |                             |    |   |    |                          |    |   |    |   |    |                              |    |                               |    |        |    |   |    |                        |    |                             |    |  |    |                          |    |                        |    |                                      |    |                  |    |        |    |                                  |    |                               |    |                           |    |  |    |  |    |                             |    |                         |    |                       |    |                         |    |                                     |    |                     |    |   |    |  |    |   |    |   |    |                             |    |                                |    |                                       |    |                  |    |                      |    |   |    |   |    |   |    |   |    |  |    |                    |    |                               |
|                    | 65   | Invalid function block parameter(s)                             |                  |    |                             |    |   |    |                          |    |   |    |   |    |                              |    |                               |    |        |    |   |    |                        |    |                             |    |  |    |                          |    |                        |    |                                      |    |                  |    |        |    |                                  |    |                               |    |                           |    |  |    |  |    |                             |    |                         |    |                       |    |                         |    |                                     |    |                     |    |   |    |  |    |   |    |   |    |                             |    |                                |    |                                       |    |                  |    |                      |    |   |    |   |    |   |    |   |    |  |    |                    |    |                               |
|                    | 66   | User heap too large   |                  |    |                             |    |   |    |                          |    |   |    |   |    |                              |    |                               |    |        |    |   |    |                        |    |                             |    |  |    |                          |    |                        |    |                                      |    |                  |    |        |    |                                  |    |                               |    |                           |    |  |    |  |    |                             |    |                         |    |                       |    |                         |    |                                     |    |                     |    |   |    |  |    |   |    |   |    |                             |    |                                |    |                                       |    |                  |    |                      |    |   |    |   |    |   |    |   |    |  |    |                    |    |                               |
|                    | 67   | RAM file does not exist or a non-RAM file id has been specified |                  |    |                             |    |   |    |                          |    |   |    |   |    |                              |    |                               |    |        |    |   |    |                        |    |                             |    |  |    |                          |    |                        |    |                                      |    |                  |    |        |    |                                  |    |                               |    |                           |    |  |    |  |    |                             |    |                         |    |                       |    |                         |    |                                     |    |                     |    |   |    |  |    |   |    |   |    |                             |    |                                |    |                                       |    |                  |    |                      |    |   |    |   |    |   |    |   |    |  |    |                    |    |                               |
|                    | 68   | The RAM file specified is not associated to an array            |                  |    |                             |    |   |    |                          |    |   |    |   |    |                              |    |                               |    |        |    |   |    |                        |    |                             |    |  |    |                          |    |                        |    |                                      |    |                  |    |        |    |                                  |    |                               |    |                           |    |  |    |  |    |                             |    |                         |    |                       |    |                         |    |                                     |    |                     |    |   |    |  |    |   |    |   |    |                             |    |                                |    |                                       |    |                  |    |                      |    |   |    |   |    |   |    |   |    |  |    |                    |    |                               |
|                    | 69   | Failed to update drive parameter database cache in Flash memory |                  |    |                             |    |   |    |                          |    |   |    |   |    |                              |    |                               |    |        |    |   |    |                        |    |                             |    |  |    |                          |    |                        |    |                                      |    |                  |    |        |    |                                  |    |                               |    |                           |    |  |    |  |    |                             |    |                         |    |                       |    |                         |    |                                     |    |                     |    |   |    |  |    |   |    |   |    |                             |    |                                |    |                                       |    |                  |    |                      |    |   |    |   |    |   |    |   |    |  |    |                    |    |                               |
| 70                 | User program downloaded while drive enabled  |   |                  |    |                             |    |   |    |                          |    |   |    |   |    |                              |    |                               |    |        |    |   |    |                        |    |                             |    |  |    |                          |    |                        |    |                                      |    |                  |    |        |    |                                  |    |                               |    |                           |    |  |    |  |    |                             |    |                         |    |                       |    |                         |    |                                     |    |                     |    |   |    |  |    |   |    |   |    |                             |    |                                |    |                                       |    |                  |    |                      |    |   |    |   |    |   |    |   |    |  |    |                    |    |                               |
| 71                 | Failed to change drive mode  |   |                  |    |                             |    |   |    |                          |    |   |    |   |    |                              |    |                               |    |        |    |   |    |                        |    |                             |    |  |    |                          |    |                        |    |                                      |    |                  |    |        |    |                                  |    |                               |    |                           |    |  |    |  |    |                             |    |                         |    |                       |    |                         |    |                                     |    |                     |    |   |    |  |    |   |    |   |    |                             |    |                                |    |                                       |    |                  |    |                      |    |   |    |   |    |   |    |   |    |  |    |                    |    |                               |
| 72                 | Invalid CTNet buffer operation   |   |                  |    |                             |    |   |    |                          |    |   |    |   |    |                              |    |                               |    |        |    |   |    |                        |    |                             |    |  |    |                          |    |                        |    |                                      |    |                  |    |        |    |                                  |    |                               |    |                           |    |  |    |  |    |                             |    |                         |    |                       |    |                         |    |                                     |    |                     |    |   |    |  |    |   |    |   |    |                             |    |                                |    |                                       |    |                  |    |                      |    |   |    |   |    |   |    |   |    |  |    |                    |    |                               |
| 73                 | Fast parameter initialisation failure  |   |                  |    |                             |    |   |    |                          |    |   |    |   |    |                              |    |                               |    |        |    |   |    |                        |    |                             |    |  |    |                          |    |                        |    |                                      |    |                  |    |        |    |                                  |    |                               |    |                           |    |  |    |  |    |                             |    |                         |    |                       |    |                         |    |                                     |    |                     |    |   |    |  |    |   |    |   |    |                             |    |                                |    |                                       |    |                  |    |                      |    |   |    |   |    |   |    |   |    |  |    |                    |    |                               |
| 74                 | Over-temperature   |   |                  |    |                             |    |   |    |                          |    |   |    |   |    |                              |    |                               |    |        |    |   |    |                        |    |                             |    |  |    |                          |    |                        |    |                                      |    |                  |    |        |    |                                  |    |                               |    |                           |    |  |    |  |    |                             |    |                         |    |                       |    |                         |    |                                     |    |                     |    |   |    |  |    |   |    |   |    |                             |    |                                |    |                                       |    |                  |    |                      |    |   |    |   |    |   |    |   |    |  |    |                    |    |                               |
| 75                 | Hardware unavailable   |   |                  |    |                             |    |   |    |                          |    |   |    |   |    |                              |    |                               |    |        |    |   |    |                        |    |                             |    |  |    |                          |    |                        |    |                                      |    |                  |    |        |    |                                  |    |                               |    |                           |    |  |    |  |    |                             |    |                         |    |                       |    |                         |    |                                     |    |                     |    |   |    |  |    |   |    |   |    |                             |    |                                |    |                                       |    |                  |    |                      |    |   |    |   |    |   |    |   |    |  |    |                    |    |                               |
| 76                 | Module type cannot be resolved. Module is not recognised.  |   |                  |    |                             |    |   |    |                          |    |   |    |   |    |                              |    |                               |    |        |    |   |    |                        |    |                             |    |  |    |                          |    |                        |    |                                      |    |                  |    |        |    |                                  |    |                               |    |                           |    |  |    |  |    |                             |    |                         |    |                       |    |                         |    |                                     |    |                     |    |   |    |  |    |   |    |   |    |                             |    |                                |    |                                       |    |                  |    |                      |    |   |    |   |    |   |    |   |    |  |    |                    |    |                               |
| 77                 | Inter-option module comms error with module in slot 1  |   |                  |    |                             |    |   |    |                          |    |   |    |   |    |                              |    |                               |    |        |    |   |    |                        |    |                             |    |  |    |                          |    |                        |    |                                      |    |                  |    |        |    |                                  |    |                               |    |                           |    |  |    |  |    |                             |    |                         |    |                       |    |                         |    |                                     |    |                     |    |   |    |  |    |   |    |   |    |                             |    |                                |    |                                       |    |                  |    |                      |    |   |    |   |    |   |    |   |    |  |    |                    |    |                               |
| 78                 | Inter-option module comms error with module in slot 2  |   |                  |    |                             |    |   |    |                          |    |   |    |   |    |                              |    |                               |    |        |    |   |    |                        |    |                             |    |  |    |                          |    |                        |    |                                      |    |                  |    |        |    |                                  |    |                               |    |                           |    |  |    |  |    |                             |    |                         |    |                       |    |                         |    |                                     |    |                     |    |   |    |  |    |   |    |   |    |                             |    |                                |    |                                       |    |                  |    |                      |    |   |    |   |    |   |    |   |    |  |    |                    |    |                               |
| 79                 | Inter-option module comms error with module in slot 3  |   |                  |    |                             |    |   |    |                          |    |   |    |   |    |                              |    |                               |    |        |    |   |    |                        |    |                             |    |  |    |                          |    |                        |    |                                      |    |                  |    |        |    |                                  |    |                               |    |                           |    |  |    |  |    |                             |    |                         |    |                       |    |                         |    |                                     |    |                     |    |   |    |  |    |   |    |   |    |                             |    |                                |    |                                       |    |                  |    |                      |    |   |    |   |    |   |    |   |    |  |    |                    |    |                               |
| 80                 | Inter-option module comms error with module unknown slot   |   |                  |    |                             |    |   |    |                          |    |   |    |   |    |                              |    |                               |    |        |    |   |    |                        |    |                             |    |  |    |                          |    |                        |    |                                      |    |                  |    |        |    |                                  |    |                               |    |                           |    |  |    |  |    |                             |    |                         |    |                       |    |                         |    |                                     |    |                     |    |   |    |  |    |   |    |   |    |                             |    |                                |    |                                       |    |                  |    |                      |    |   |    |   |    |   |    |   |    |  |    |                    |    |                               |
| 81                 | APC internal error   |   |                  |    |                             |    |   |    |                          |    |   |    |   |    |                              |    |                               |    |        |    |   |    |                        |    |                             |    |  |    |                          |    |                        |    |                                      |    |                  |    |        |    |                                  |    |                               |    |                           |    |  |    |  |    |                             |    |                         |    |                       |    |                         |    |                                     |    |                     |    |   |    |  |    |   |    |   |    |                             |    |                                |    |                                       |    |                  |    |                      |    |   |    |   |    |   |    |   |    |  |    |                    |    |                               |
| 82                 | Communcations to drive faulty  |   |                  |    |                             |    |   |    |                          |    |   |    |   |    |                              |    |                               |    |        |    |   |    |                        |    |                             |    |  |    |                          |    |                        |    |                                      |    |                  |    |        |    |                                  |    |                               |    |                           |    |  |    |  |    |                             |    |                         |    |                       |    |                         |    |                                     |    |                     |    |   |    |  |    |   |    |   |    |                             |    |                                |    |                                       |    |                  |    |                      |    |   |    |   |    |   |    |   |    |  |    |                    |    |                               |

| Trip          | Diagnosis  |  |   |                  |   |     |           |    |   |                         |    |  |   |         |                        |                              |         |  |              |         |                          |                       |              |                                     |               |     |                         |                    |    |                          |                      |  |             |  |    |     |                                   |    |             |                             |    |             |                                     |    |                        |                                   |    |                        |                                |    |                        |                                |    |                        |                                |    |             |                         |    |             |                   |    |             |                          |    |             |                     |    |     |                         |    |     |                         |
|---------------|--|--|---|------------------|---|-----|-----------|----|---|-------------------------|----|--|---|---------|------------------------|------------------------------|---------|--|--------------|---------|--------------------------|-----------------------|--------------|-------------------------------------|---------------|-----|-------------------------|--------------------|----|--------------------------|----------------------|--|-------------|--|----|-----|-----------------------------------|----|-------------|-----------------------------|----|-------------|-------------------------------------|----|------------------------|-----------------------------------|----|------------------------|--------------------------------|----|------------------------|--------------------------------|----|------------------------|--------------------------------|----|-------------|-------------------------|----|-------------|-------------------|----|-------------|--------------------------|----|-------------|---------------------|----|-----|-------------------------|----|-----|-------------------------|
| <b>SLX.Er</b> | <b>Solutions Module slot X trip: Solutions Module in slot X has detected a fault</b>   |  |   |                  |   |     |           |    |   |                         |    |  |   |         |                        |                              |         |  |              |         |                          |                       |              |                                     |               |     |                         |                    |    |                          |                      |  |             |  |    |     |                                   |    |             |                             |    |             |                                     |    |                        |                                   |    |                        |                                |    |                        |                                |    |                        |                                |    |             |                         |    |             |                   |    |             |                          |    |             |                     |    |     |                         |    |     |                         |
| 202,207,212   | <p><b>Automation (I/O Expansion) module category</b></p> <p>Check value in Pr 15/16/17.50. The following table lists the possible error codes for the SM-I/O Plus, SM-I/O Lite, SM-I/O Timer, SM-PELV and SM-I/O 120V modules. See the <i>Diagnostics</i> section in the relevant Solutions Module User Guide for more information.</p> <table border="1"> <thead> <tr> <th>Error code</th> <th>Module</th> <th>Reason for fault</th> </tr> </thead> <tbody> <tr> <td>0</td> <td>All</td> <td>No errors</td> </tr> <tr> <td>1</td> <td>All</td> <td>Digital output overload</td> </tr> <tr> <td rowspan="2">2</td> <td>SM-I/O Lite, SM-I/O Timer</td> <td>Analogue input 1 current input too high (&gt;22mA) or too low (&lt;3mA)</td> </tr> <tr> <td>SM-PELV</td> <td>Digital input overload</td> </tr> <tr> <td>3</td> <td>SM-PELV</td> <td>Analogue input 1 current input too low (&lt;3mA)</td> </tr> <tr> <td>4</td> <td>SM-PELV</td> <td>User power supply absent</td> </tr> <tr> <td>5</td> <td>SM-I/O Timer</td> <td>Real time clock communication error</td> </tr> <tr> <td>74</td> <td>All</td> <td>Module over temperature</td> </tr> </tbody> </table>   | Error code   | Module  | Reason for fault | 0 | All | No errors | 1  | All   | Digital output overload | 2  | SM-I/O Lite, SM-I/O Timer  | Analogue input 1 current input too high (>22mA) or too low (<3mA) | SM-PELV | Digital input overload | 3                            | SM-PELV | Analogue input 1 current input too low (<3mA)                    | 4            | SM-PELV | User power supply absent | 5                     | SM-I/O Timer | Real time clock communication error | 74            | All | Module over temperature |                    |    |                          |                      |  |             |  |    |     |                                   |    |             |                             |    |             |                                     |    |                        |                                   |    |                        |                                |    |                        |                                |    |                        |                                |    |             |                         |    |             |                   |    |             |                          |    |             |                     |    |     |                         |    |     |                         |
|               | Error code   | Module   | Reason for fault  |                  |   |     |           |    |   |                         |    |  |   |         |                        |                              |         |  |              |         |                          |                       |              |                                     |               |     |                         |                    |    |                          |                      |  |             |  |    |     |                                   |    |             |                             |    |             |                                     |    |                        |                                   |    |                        |                                |    |                        |                                |    |                        |                                |    |             |                         |    |             |                   |    |             |                          |    |             |                     |    |     |                         |    |     |                         |
|               | 0  | All  | No errors   |                  |   |     |           |    |   |                         |    |  |   |         |                        |                              |         |  |              |         |                          |                       |              |                                     |               |     |                         |                    |    |                          |                      |  |             |  |    |     |                                   |    |             |                             |    |             |                                     |    |                        |                                   |    |                        |                                |    |                        |                                |    |                        |                                |    |             |                         |    |             |                   |    |             |                          |    |             |                     |    |     |                         |    |     |                         |
|               | 1  | All  | Digital output overload   |                  |   |     |           |    |   |                         |    |  |   |         |                        |                              |         |  |              |         |                          |                       |              |                                     |               |     |                         |                    |    |                          |                      |  |             |  |    |     |                                   |    |             |                             |    |             |                                     |    |                        |                                   |    |                        |                                |    |                        |                                |    |                        |                                |    |             |                         |    |             |                   |    |             |                          |    |             |                     |    |     |                         |    |     |                         |
|               | 2  | SM-I/O Lite, SM-I/O Timer  | Analogue input 1 current input too high (>22mA) or too low (<3mA) |                  |   |     |           |    |   |                         |    |  |   |         |                        |                              |         |  |              |         |                          |                       |              |                                     |               |     |                         |                    |    |                          |                      |  |             |  |    |     |                                   |    |             |                             |    |             |                                     |    |                        |                                   |    |                        |                                |    |                        |                                |    |                        |                                |    |             |                         |    |             |                   |    |             |                          |    |             |                     |    |     |                         |    |     |                         |
|               |  | SM-PELV  | Digital input overload  |                  |   |     |           |    |   |                         |    |  |   |         |                        |                              |         |  |              |         |                          |                       |              |                                     |               |     |                         |                    |    |                          |                      |  |             |  |    |     |                                   |    |             |                             |    |             |                                     |    |                        |                                   |    |                        |                                |    |                        |                                |    |                        |                                |    |             |                         |    |             |                   |    |             |                          |    |             |                     |    |     |                         |    |     |                         |
|               | 3  | SM-PELV  | Analogue input 1 current input too low (<3mA)                     |                  |   |     |           |    |   |                         |    |  |   |         |                        |                              |         |  |              |         |                          |                       |              |                                     |               |     |                         |                    |    |                          |                      |  |             |  |    |     |                                   |    |             |                             |    |             |                                     |    |                        |                                   |    |                        |                                |    |                        |                                |    |                        |                                |    |             |                         |    |             |                   |    |             |                          |    |             |                     |    |     |                         |    |     |                         |
|               | 4  | SM-PELV  | User power supply absent  |                  |   |     |           |    |   |                         |    |  |   |         |                        |                              |         |  |              |         |                          |                       |              |                                     |               |     |                         |                    |    |                          |                      |  |             |  |    |     |                                   |    |             |                             |    |             |                                     |    |                        |                                   |    |                        |                                |    |                        |                                |    |                        |                                |    |             |                         |    |             |                   |    |             |                          |    |             |                     |    |     |                         |    |     |                         |
|               | 5  | SM-I/O Timer   | Real time clock communication error                               |                  |   |     |           |    |   |                         |    |  |   |         |                        |                              |         |  |              |         |                          |                       |              |                                     |               |     |                         |                    |    |                          |                      |  |             |  |    |     |                                   |    |             |                             |    |             |                                     |    |                        |                                   |    |                        |                                |    |                        |                                |    |                        |                                |    |             |                         |    |             |                   |    |             |                          |    |             |                     |    |     |                         |    |     |                         |
|               | 74   | All  | Module over temperature   |                  |   |     |           |    |   |                         |    |  |   |         |                        |                              |         |  |              |         |                          |                       |              |                                     |               |     |                         |                    |    |                          |                      |  |             |  |    |     |                                   |    |             |                             |    |             |                                     |    |                        |                                   |    |                        |                                |    |                        |                                |    |                        |                                |    |             |                         |    |             |                   |    |             |                          |    |             |                     |    |     |                         |    |     |                         |
| <b>SLX.Er</b> | <b>Solutions Module slot X trip: Solutions Module in slot X has detected a fault</b>   |  |   |                  |   |     |           |    |   |                         |    |  |   |         |                        |                              |         |  |              |         |                          |                       |              |                                     |               |     |                         |                    |    |                          |                      |  |             |  |    |     |                                   |    |             |                             |    |             |                                     |    |                        |                                   |    |                        |                                |    |                        |                                |    |                        |                                |    |             |                         |    |             |                   |    |             |                          |    |             |                     |    |     |                         |    |     |                         |
| 202,207,212   | <p><b>Fieldbus module category</b></p> <p>Check value in Pr 15/16/17.50. The following table lists the possible error codes for the Fieldbus modules. See the <i>Diagnostics</i> section in the relevant Solutions Module User Guide for more information.</p> <table border="1"> <thead> <tr> <th>Error code</th> <th>Module</th> <th>Trip Description</th> </tr> </thead> <tbody> <tr> <td>0</td> <td>All</td> <td>No trip</td> </tr> <tr> <td>52</td> <td>SM-PROFIBUS-DP, SM-Interbus, SM-DeviceNet, SM-CANOpen</td> <td>User control word trip</td> </tr> <tr> <td>61</td> <td>SM-PROFIBUS-DP, SM-Interbus, SM-DeviceNet, SM-CANOpen, SM-SERCOS</td> <td>Configuration error</td> </tr> <tr> <td>64</td> <td>SM-DeviceNet</td> <td>Expected packet rate timeout</td> </tr> <tr> <td>65</td> <td>SM-PROFIBUS-DP, SM-Interbus, SM-DeviceNet, SM-CANOpen, SM-SERCOS</td> <td>Network loss</td> </tr> <tr> <td>66</td> <td>SM-PROFIBUS-DP</td> <td>Critical link failure</td> </tr> <tr> <td></td> <td>SM-CAN, SM-DeviceNet, SM-CANOpen</td> <td>Bus off error</td> </tr> <tr> <td>69</td> <td>SM-CAN</td> <td>No acknowledgement</td> </tr> <tr> <td>70</td> <td>All (except SM-Ethernet)</td> <td>Flash transfer error</td> </tr> <tr> <td></td> <td>SM-Ethernet</td> <td>No valid menu data available for the module from the drive</td> </tr> <tr> <td>74</td> <td>All</td> <td>Solutions module over temperature</td> </tr> <tr> <td>75</td> <td>SM-Ethernet</td> <td>The drive is not responding</td> </tr> <tr> <td>76</td> <td>SM-Ethernet</td> <td>The Modbus connection has timed out</td> </tr> <tr> <td>80</td> <td>All (except SM-SERCOS)</td> <td>Inter-option communications error</td> </tr> <tr> <td>81</td> <td>All (except SM-SERCOS)</td> <td>Communications error to slot 1</td> </tr> <tr> <td>82</td> <td>All (except SM-SERCOS)</td> <td>Communications error to slot 2</td> </tr> <tr> <td>83</td> <td>All (except SM-SERCOS)</td> <td>Communications error to slot 3</td> </tr> <tr> <td>84</td> <td>SM-Ethernet</td> <td>Memory allocation error</td> </tr> <tr> <td>85</td> <td>SM-Ethernet</td> <td>File system error</td> </tr> <tr> <td>86</td> <td>SM-Ethernet</td> <td>Configuration file error</td> </tr> <tr> <td>87</td> <td>SM-Ethernet</td> <td>Language file error</td> </tr> <tr> <td>98</td> <td>All</td> <td>Internal watchdog error</td> </tr> <tr> <td>99</td> <td>All</td> <td>Internal software error</td> </tr> </tbody> </table> | Error code   | Module  | Trip Description | 0 | All | No trip   | 52 | SM-PROFIBUS-DP, SM-Interbus, SM-DeviceNet, SM-CANOpen | User control word trip  | 61 | SM-PROFIBUS-DP, SM-Interbus, SM-DeviceNet, SM-CANOpen, SM-SERCOS | Configuration error   | 64      | SM-DeviceNet           | Expected packet rate timeout | 65      | SM-PROFIBUS-DP, SM-Interbus, SM-DeviceNet, SM-CANOpen, SM-SERCOS | Network loss | 66      | SM-PROFIBUS-DP           | Critical link failure |              | SM-CAN, SM-DeviceNet, SM-CANOpen    | Bus off error | 69  | SM-CAN                  | No acknowledgement | 70 | All (except SM-Ethernet) | Flash transfer error |  | SM-Ethernet | No valid menu data available for the module from the drive | 74 | All | Solutions module over temperature | 75 | SM-Ethernet | The drive is not responding | 76 | SM-Ethernet | The Modbus connection has timed out | 80 | All (except SM-SERCOS) | Inter-option communications error | 81 | All (except SM-SERCOS) | Communications error to slot 1 | 82 | All (except SM-SERCOS) | Communications error to slot 2 | 83 | All (except SM-SERCOS) | Communications error to slot 3 | 84 | SM-Ethernet | Memory allocation error | 85 | SM-Ethernet | File system error | 86 | SM-Ethernet | Configuration file error | 87 | SM-Ethernet | Language file error | 98 | All | Internal watchdog error | 99 | All | Internal software error |
|               | Error code   | Module   | Trip Description  |                  |   |     |           |    |   |                         |    |  |   |         |                        |                              |         |  |              |         |                          |                       |              |                                     |               |     |                         |                    |    |                          |                      |  |             |  |    |     |                                   |    |             |                             |    |             |                                     |    |                        |                                   |    |                        |                                |    |                        |                                |    |                        |                                |    |             |                         |    |             |                   |    |             |                          |    |             |                     |    |     |                         |    |     |                         |
|               | 0  | All  | No trip   |                  |   |     |           |    |   |                         |    |  |   |         |                        |                              |         |  |              |         |                          |                       |              |                                     |               |     |                         |                    |    |                          |                      |  |             |  |    |     |                                   |    |             |                             |    |             |                                     |    |                        |                                   |    |                        |                                |    |                        |                                |    |                        |                                |    |             |                         |    |             |                   |    |             |                          |    |             |                     |    |     |                         |    |     |                         |
|               | 52   | SM-PROFIBUS-DP, SM-Interbus, SM-DeviceNet, SM-CANOpen            | User control word trip  |                  |   |     |           |    |   |                         |    |  |   |         |                        |                              |         |  |              |         |                          |                       |              |                                     |               |     |                         |                    |    |                          |                      |  |             |  |    |     |                                   |    |             |                             |    |             |                                     |    |                        |                                   |    |                        |                                |    |                        |                                |    |                        |                                |    |             |                         |    |             |                   |    |             |                          |    |             |                     |    |     |                         |    |     |                         |
|               | 61   | SM-PROFIBUS-DP, SM-Interbus, SM-DeviceNet, SM-CANOpen, SM-SERCOS | Configuration error   |                  |   |     |           |    |   |                         |    |  |   |         |                        |                              |         |  |              |         |                          |                       |              |                                     |               |     |                         |                    |    |                          |                      |  |             |  |    |     |                                   |    |             |                             |    |             |                                     |    |                        |                                   |    |                        |                                |    |                        |                                |    |                        |                                |    |             |                         |    |             |                   |    |             |                          |    |             |                     |    |     |                         |    |     |                         |
|               | 64   | SM-DeviceNet   | Expected packet rate timeout                                      |                  |   |     |           |    |   |                         |    |  |   |         |                        |                              |         |  |              |         |                          |                       |              |                                     |               |     |                         |                    |    |                          |                      |  |             |  |    |     |                                   |    |             |                             |    |             |                                     |    |                        |                                   |    |                        |                                |    |                        |                                |    |                        |                                |    |             |                         |    |             |                   |    |             |                          |    |             |                     |    |     |                         |    |     |                         |
|               | 65   | SM-PROFIBUS-DP, SM-Interbus, SM-DeviceNet, SM-CANOpen, SM-SERCOS | Network loss  |                  |   |     |           |    |   |                         |    |  |   |         |                        |                              |         |  |              |         |                          |                       |              |                                     |               |     |                         |                    |    |                          |                      |  |             |  |    |     |                                   |    |             |                             |    |             |                                     |    |                        |                                   |    |                        |                                |    |                        |                                |    |                        |                                |    |             |                         |    |             |                   |    |             |                          |    |             |                     |    |     |                         |    |     |                         |
|               | 66   | SM-PROFIBUS-DP   | Critical link failure   |                  |   |     |           |    |   |                         |    |  |   |         |                        |                              |         |  |              |         |                          |                       |              |                                     |               |     |                         |                    |    |                          |                      |  |             |  |    |     |                                   |    |             |                             |    |             |                                     |    |                        |                                   |    |                        |                                |    |                        |                                |    |                        |                                |    |             |                         |    |             |                   |    |             |                          |    |             |                     |    |     |                         |    |     |                         |
|               |  | SM-CAN, SM-DeviceNet, SM-CANOpen                                 | Bus off error   |                  |   |     |           |    |   |                         |    |  |   |         |                        |                              |         |  |              |         |                          |                       |              |                                     |               |     |                         |                    |    |                          |                      |  |             |  |    |     |                                   |    |             |                             |    |             |                                     |    |                        |                                   |    |                        |                                |    |                        |                                |    |                        |                                |    |             |                         |    |             |                   |    |             |                          |    |             |                     |    |     |                         |    |     |                         |
|               | 69   | SM-CAN   | No acknowledgement  |                  |   |     |           |    |   |                         |    |  |   |         |                        |                              |         |  |              |         |                          |                       |              |                                     |               |     |                         |                    |    |                          |                      |  |             |  |    |     |                                   |    |             |                             |    |             |                                     |    |                        |                                   |    |                        |                                |    |                        |                                |    |                        |                                |    |             |                         |    |             |                   |    |             |                          |    |             |                     |    |     |                         |    |     |                         |
|               | 70   | All (except SM-Ethernet)   | Flash transfer error  |                  |   |     |           |    |   |                         |    |  |   |         |                        |                              |         |  |              |         |                          |                       |              |                                     |               |     |                         |                    |    |                          |                      |  |             |  |    |     |                                   |    |             |                             |    |             |                                     |    |                        |                                   |    |                        |                                |    |                        |                                |    |                        |                                |    |             |                         |    |             |                   |    |             |                          |    |             |                     |    |     |                         |    |     |                         |
|               |  | SM-Ethernet  | No valid menu data available for the module from the drive        |                  |   |     |           |    |   |                         |    |  |   |         |                        |                              |         |  |              |         |                          |                       |              |                                     |               |     |                         |                    |    |                          |                      |  |             |  |    |     |                                   |    |             |                             |    |             |                                     |    |                        |                                   |    |                        |                                |    |                        |                                |    |                        |                                |    |             |                         |    |             |                   |    |             |                          |    |             |                     |    |     |                         |    |     |                         |
|               | 74   | All  | Solutions module over temperature                                 |                  |   |     |           |    |   |                         |    |  |   |         |                        |                              |         |  |              |         |                          |                       |              |                                     |               |     |                         |                    |    |                          |                      |  |             |  |    |     |                                   |    |             |                             |    |             |                                     |    |                        |                                   |    |                        |                                |    |                        |                                |    |                        |                                |    |             |                         |    |             |                   |    |             |                          |    |             |                     |    |     |                         |    |     |                         |
|               | 75   | SM-Ethernet  | The drive is not responding                                       |                  |   |     |           |    |   |                         |    |  |   |         |                        |                              |         |  |              |         |                          |                       |              |                                     |               |     |                         |                    |    |                          |                      |  |             |  |    |     |                                   |    |             |                             |    |             |                                     |    |                        |                                   |    |                        |                                |    |                        |                                |    |                        |                                |    |             |                         |    |             |                   |    |             |                          |    |             |                     |    |     |                         |    |     |                         |
|               | 76   | SM-Ethernet  | The Modbus connection has timed out                               |                  |   |     |           |    |   |                         |    |  |   |         |                        |                              |         |  |              |         |                          |                       |              |                                     |               |     |                         |                    |    |                          |                      |  |             |  |    |     |                                   |    |             |                             |    |             |                                     |    |                        |                                   |    |                        |                                |    |                        |                                |    |                        |                                |    |             |                         |    |             |                   |    |             |                          |    |             |                     |    |     |                         |    |     |                         |
|               | 80   | All (except SM-SERCOS)   | Inter-option communications error                                 |                  |   |     |           |    |   |                         |    |  |   |         |                        |                              |         |  |              |         |                          |                       |              |                                     |               |     |                         |                    |    |                          |                      |  |             |  |    |     |                                   |    |             |                             |    |             |                                     |    |                        |                                   |    |                        |                                |    |                        |                                |    |                        |                                |    |             |                         |    |             |                   |    |             |                          |    |             |                     |    |     |                         |    |     |                         |
|               | 81   | All (except SM-SERCOS)   | Communications error to slot 1                                    |                  |   |     |           |    |   |                         |    |  |   |         |                        |                              |         |  |              |         |                          |                       |              |                                     |               |     |                         |                    |    |                          |                      |  |             |  |    |     |                                   |    |             |                             |    |             |                                     |    |                        |                                   |    |                        |                                |    |                        |                                |    |                        |                                |    |             |                         |    |             |                   |    |             |                          |    |             |                     |    |     |                         |    |     |                         |
|               | 82   | All (except SM-SERCOS)   | Communications error to slot 2                                    |                  |   |     |           |    |   |                         |    |  |   |         |                        |                              |         |  |              |         |                          |                       |              |                                     |               |     |                         |                    |    |                          |                      |  |             |  |    |     |                                   |    |             |                             |    |             |                                     |    |                        |                                   |    |                        |                                |    |                        |                                |    |                        |                                |    |             |                         |    |             |                   |    |             |                          |    |             |                     |    |     |                         |    |     |                         |
|               | 83   | All (except SM-SERCOS)   | Communications error to slot 3                                    |                  |   |     |           |    |   |                         |    |  |   |         |                        |                              |         |  |              |         |                          |                       |              |                                     |               |     |                         |                    |    |                          |                      |  |             |  |    |     |                                   |    |             |                             |    |             |                                     |    |                        |                                   |    |                        |                                |    |                        |                                |    |                        |                                |    |             |                         |    |             |                   |    |             |                          |    |             |                     |    |     |                         |    |     |                         |
|               | 84   | SM-Ethernet  | Memory allocation error   |                  |   |     |           |    |   |                         |    |  |   |         |                        |                              |         |  |              |         |                          |                       |              |                                     |               |     |                         |                    |    |                          |                      |  |             |  |    |     |                                   |    |             |                             |    |             |                                     |    |                        |                                   |    |                        |                                |    |                        |                                |    |                        |                                |    |             |                         |    |             |                   |    |             |                          |    |             |                     |    |     |                         |    |     |                         |
|               | 85   | SM-Ethernet  | File system error   |                  |   |     |           |    |   |                         |    |  |   |         |                        |                              |         |  |              |         |                          |                       |              |                                     |               |     |                         |                    |    |                          |                      |  |             |  |    |     |                                   |    |             |                             |    |             |                                     |    |                        |                                   |    |                        |                                |    |                        |                                |    |                        |                                |    |             |                         |    |             |                   |    |             |                          |    |             |                     |    |     |                         |    |     |                         |
|               | 86   | SM-Ethernet  | Configuration file error  |                  |   |     |           |    |   |                         |    |  |   |         |                        |                              |         |  |              |         |                          |                       |              |                                     |               |     |                         |                    |    |                          |                      |  |             |  |    |     |                                   |    |             |                             |    |             |                                     |    |                        |                                   |    |                        |                                |    |                        |                                |    |                        |                                |    |             |                         |    |             |                   |    |             |                          |    |             |                     |    |     |                         |    |     |                         |
|               | 87   | SM-Ethernet  | Language file error   |                  |   |     |           |    |   |                         |    |  |   |         |                        |                              |         |  |              |         |                          |                       |              |                                     |               |     |                         |                    |    |                          |                      |  |             |  |    |     |                                   |    |             |                             |    |             |                                     |    |                        |                                   |    |                        |                                |    |                        |                                |    |                        |                                |    |             |                         |    |             |                   |    |             |                          |    |             |                     |    |     |                         |    |     |                         |
|               | 98   | All  | Internal watchdog error   |                  |   |     |           |    |   |                         |    |  |   |         |                        |                              |         |  |              |         |                          |                       |              |                                     |               |     |                         |                    |    |                          |                      |  |             |  |    |     |                                   |    |             |                             |    |             |                                     |    |                        |                                   |    |                        |                                |    |                        |                                |    |                        |                                |    |             |                         |    |             |                   |    |             |                          |    |             |                     |    |     |                         |    |     |                         |
|               | 99   | All  | Internal software error   |                  |   |     |           |    |   |                         |    |  |   |         |                        |                              |         |  |              |         |                          |                       |              |                                     |               |     |                         |                    |    |                          |                      |  |             |  |    |     |                                   |    |             |                             |    |             |                                     |    |                        |                                   |    |                        |                                |    |                        |                                |    |                        |                                |    |             |                         |    |             |                   |    |             |                          |    |             |                     |    |     |                         |    |     |                         |

| Trip                | Diagnosis  |  |                  |   |                   |   |                         |   |                        |   |                 |   |  |   |                                     |   |               |   |  |   |                                 |   |  |    |                         |    |                                   |    |                                 |    |                             |    |                          |    |                          |    |                        |    |                              |    |                              |    |                   |    |                                   |
|---------------------|--|--|------------------|---|-------------------|---|-------------------------|---|------------------------|---|-----------------|---|--|---|-------------------------------------|---|---------------|---|--|---|---------------------------------|---|--|----|-------------------------|----|-----------------------------------|----|---------------------------------|----|-----------------------------|----|--------------------------|----|--------------------------|----|------------------------|----|------------------------------|----|------------------------------|----|-------------------|----|-----------------------------------|
| <b>SLX.Er</b>       | <b>Solutions Module slot X trip: Solutions Module in slot X has detected a fault</b>   |  |                  |   |                   |   |                         |   |                        |   |                 |   |  |   |                                     |   |               |   |  |   |                                 |   |  |    |                         |    |                                   |    |                                 |    |                             |    |                          |    |                          |    |                        |    |                              |    |                              |    |                   |    |                                   |
| <b>202,207,212</b>  | <b>SLM module category</b><br>Check value in Pr <b>15/16/17.50</b> . The following table lists the possible error codes for the SM-SLM. See the <i>Diagnostics</i> section in the <i>SM-SLM User Guide</i> for more information.   |  |                  |   |                   |   |                         |   |                        |   |                 |   |  |   |                                     |   |               |   |  |   |                                 |   |  |    |                         |    |                                   |    |                                 |    |                             |    |                          |    |                          |    |                        |    |                              |    |                              |    |                   |    |                                   |
|                     | <table border="1"> <thead> <tr> <th>Error Code</th> <th>Trip Description</th> </tr> </thead> <tbody> <tr><td>0</td><td>No fault detected</td></tr> <tr><td>1</td><td>Power supply overloaded</td></tr> <tr><td>2</td><td>SLM version is too low</td></tr> <tr><td>3</td><td>DriveLink error</td></tr> <tr><td>4</td><td>Incorrect switching frequency selected</td></tr> <tr><td>5</td><td>Feedback source selection incorrect</td></tr> <tr><td>6</td><td>Encoder error</td></tr> <tr><td>7</td><td>Motor object number of instances error</td></tr> <tr><td>8</td><td>Motor object list version error</td></tr> <tr><td>9</td><td>Performance object number of instances error</td></tr> <tr><td>10</td><td>Parameter channel error</td></tr> <tr><td>11</td><td>Drive operating mode incompatible</td></tr> <tr><td>12</td><td>Error writing to the SLM EEPROM</td></tr> <tr><td>13</td><td>Motor object type incorrect</td></tr> <tr><td>14</td><td>Unidrive SP object error</td></tr> <tr><td>15</td><td>Encoder object CRC error</td></tr> <tr><td>16</td><td>Motor object CRC error</td></tr> <tr><td>17</td><td>Performance object CRC error</td></tr> <tr><td>18</td><td>Unidrive SP object CRC error</td></tr> <tr><td>19</td><td>Sequencer timeout</td></tr> <tr><td>74</td><td>Solutions module over temperature</td></tr> </tbody> </table> | Error Code                                   | Trip Description | 0 | No fault detected | 1 | Power supply overloaded | 2 | SLM version is too low | 3 | DriveLink error | 4 | Incorrect switching frequency selected | 5 | Feedback source selection incorrect | 6 | Encoder error | 7 | Motor object number of instances error | 8 | Motor object list version error | 9 | Performance object number of instances error | 10 | Parameter channel error | 11 | Drive operating mode incompatible | 12 | Error writing to the SLM EEPROM | 13 | Motor object type incorrect | 14 | Unidrive SP object error | 15 | Encoder object CRC error | 16 | Motor object CRC error | 17 | Performance object CRC error | 18 | Unidrive SP object CRC error | 19 | Sequencer timeout | 74 | Solutions module over temperature |
|                     | Error Code   | Trip Description                             |                  |   |                   |   |                         |   |                        |   |                 |   |  |   |                                     |   |               |   |  |   |                                 |   |  |    |                         |    |                                   |    |                                 |    |                             |    |                          |    |                          |    |                        |    |                              |    |                              |    |                   |    |                                   |
|                     | 0  | No fault detected                            |                  |   |                   |   |                         |   |                        |   |                 |   |  |   |                                     |   |               |   |  |   |                                 |   |  |    |                         |    |                                   |    |                                 |    |                             |    |                          |    |                          |    |                        |    |                              |    |                              |    |                   |    |                                   |
|                     | 1  | Power supply overloaded                      |                  |   |                   |   |                         |   |                        |   |                 |   |  |   |                                     |   |               |   |  |   |                                 |   |  |    |                         |    |                                   |    |                                 |    |                             |    |                          |    |                          |    |                        |    |                              |    |                              |    |                   |    |                                   |
|                     | 2  | SLM version is too low                       |                  |   |                   |   |                         |   |                        |   |                 |   |  |   |                                     |   |               |   |  |   |                                 |   |  |    |                         |    |                                   |    |                                 |    |                             |    |                          |    |                          |    |                        |    |                              |    |                              |    |                   |    |                                   |
|                     | 3  | DriveLink error                              |                  |   |                   |   |                         |   |                        |   |                 |   |  |   |                                     |   |               |   |  |   |                                 |   |  |    |                         |    |                                   |    |                                 |    |                             |    |                          |    |                          |    |                        |    |                              |    |                              |    |                   |    |                                   |
|                     | 4  | Incorrect switching frequency selected       |                  |   |                   |   |                         |   |                        |   |                 |   |  |   |                                     |   |               |   |  |   |                                 |   |  |    |                         |    |                                   |    |                                 |    |                             |    |                          |    |                          |    |                        |    |                              |    |                              |    |                   |    |                                   |
|                     | 5  | Feedback source selection incorrect          |                  |   |                   |   |                         |   |                        |   |                 |   |  |   |                                     |   |               |   |  |   |                                 |   |  |    |                         |    |                                   |    |                                 |    |                             |    |                          |    |                          |    |                        |    |                              |    |                              |    |                   |    |                                   |
|                     | 6  | Encoder error                                |                  |   |                   |   |                         |   |                        |   |                 |   |  |   |                                     |   |               |   |  |   |                                 |   |  |    |                         |    |                                   |    |                                 |    |                             |    |                          |    |                          |    |                        |    |                              |    |                              |    |                   |    |                                   |
|                     | 7  | Motor object number of instances error       |                  |   |                   |   |                         |   |                        |   |                 |   |  |   |                                     |   |               |   |  |   |                                 |   |  |    |                         |    |                                   |    |                                 |    |                             |    |                          |    |                          |    |                        |    |                              |    |                              |    |                   |    |                                   |
|                     | 8  | Motor object list version error              |                  |   |                   |   |                         |   |                        |   |                 |   |  |   |                                     |   |               |   |  |   |                                 |   |  |    |                         |    |                                   |    |                                 |    |                             |    |                          |    |                          |    |                        |    |                              |    |                              |    |                   |    |                                   |
|                     | 9  | Performance object number of instances error |                  |   |                   |   |                         |   |                        |   |                 |   |  |   |                                     |   |               |   |  |   |                                 |   |  |    |                         |    |                                   |    |                                 |    |                             |    |                          |    |                          |    |                        |    |                              |    |                              |    |                   |    |                                   |
|                     | 10   | Parameter channel error                      |                  |   |                   |   |                         |   |                        |   |                 |   |  |   |                                     |   |               |   |  |   |                                 |   |  |    |                         |    |                                   |    |                                 |    |                             |    |                          |    |                          |    |                        |    |                              |    |                              |    |                   |    |                                   |
|                     | 11   | Drive operating mode incompatible            |                  |   |                   |   |                         |   |                        |   |                 |   |  |   |                                     |   |               |   |  |   |                                 |   |  |    |                         |    |                                   |    |                                 |    |                             |    |                          |    |                          |    |                        |    |                              |    |                              |    |                   |    |                                   |
|                     | 12   | Error writing to the SLM EEPROM              |                  |   |                   |   |                         |   |                        |   |                 |   |  |   |                                     |   |               |   |  |   |                                 |   |  |    |                         |    |                                   |    |                                 |    |                             |    |                          |    |                          |    |                        |    |                              |    |                              |    |                   |    |                                   |
|                     | 13   | Motor object type incorrect                  |                  |   |                   |   |                         |   |                        |   |                 |   |  |   |                                     |   |               |   |  |   |                                 |   |  |    |                         |    |                                   |    |                                 |    |                             |    |                          |    |                          |    |                        |    |                              |    |                              |    |                   |    |                                   |
|                     | 14   | Unidrive SP object error                     |                  |   |                   |   |                         |   |                        |   |                 |   |  |   |                                     |   |               |   |  |   |                                 |   |  |    |                         |    |                                   |    |                                 |    |                             |    |                          |    |                          |    |                        |    |                              |    |                              |    |                   |    |                                   |
|                     | 15   | Encoder object CRC error                     |                  |   |                   |   |                         |   |                        |   |                 |   |  |   |                                     |   |               |   |  |   |                                 |   |  |    |                         |    |                                   |    |                                 |    |                             |    |                          |    |                          |    |                        |    |                              |    |                              |    |                   |    |                                   |
|                     | 16   | Motor object CRC error                       |                  |   |                   |   |                         |   |                        |   |                 |   |  |   |                                     |   |               |   |  |   |                                 |   |  |    |                         |    |                                   |    |                                 |    |                             |    |                          |    |                          |    |                        |    |                              |    |                              |    |                   |    |                                   |
|                     | 17   | Performance object CRC error                 |                  |   |                   |   |                         |   |                        |   |                 |   |  |   |                                     |   |               |   |  |   |                                 |   |  |    |                         |    |                                   |    |                                 |    |                             |    |                          |    |                          |    |                        |    |                              |    |                              |    |                   |    |                                   |
| 18                  | Unidrive SP object CRC error   |  |                  |   |                   |   |                         |   |                        |   |                 |   |  |   |                                     |   |               |   |  |   |                                 |   |  |    |                         |    |                                   |    |                                 |    |                             |    |                          |    |                          |    |                        |    |                              |    |                              |    |                   |    |                                   |
| 19                  | Sequencer timeout  |  |                  |   |                   |   |                         |   |                        |   |                 |   |  |   |                                     |   |               |   |  |   |                                 |   |  |    |                         |    |                                   |    |                                 |    |                             |    |                          |    |                          |    |                        |    |                              |    |                              |    |                   |    |                                   |
| 74                  | Solutions module over temperature  |  |                  |   |                   |   |                         |   |                        |   |                 |   |  |   |                                     |   |               |   |  |   |                                 |   |  |    |                         |    |                                   |    |                                 |    |                             |    |                          |    |                          |    |                        |    |                              |    |                              |    |                   |    |                                   |
| <b>SLX.HF</b>       | <b>Solutions Module slot X trip: Solutions Module X hardware fault</b>   |  |                  |   |                   |   |                         |   |                        |   |                 |   |  |   |                                     |   |               |   |  |   |                                 |   |  |    |                         |    |                                   |    |                                 |    |                             |    |                          |    |                          |    |                        |    |                              |    |                              |    |                   |    |                                   |
| <b>200,205,210</b>  | Ensure Solutions Module is fitted correctly<br>Return Solutions Module to supplier   |  |                  |   |                   |   |                         |   |                        |   |                 |   |  |   |                                     |   |               |   |  |   |                                 |   |  |    |                         |    |                                   |    |                                 |    |                             |    |                          |    |                          |    |                        |    |                              |    |                              |    |                   |    |                                   |
| <b>SLX.nF</b>       | <b>Solutions Module slot X trip: Solutions Module has been removed</b>   |  |                  |   |                   |   |                         |   |                        |   |                 |   |  |   |                                     |   |               |   |  |   |                                 |   |  |    |                         |    |                                   |    |                                 |    |                             |    |                          |    |                          |    |                        |    |                              |    |                              |    |                   |    |                                   |
| <b>203,208,213</b>  | Ensure Solutions Module is fitted correctly<br>Re-fit Solutions Module<br>Save parameters and reset drive  |  |                  |   |                   |   |                         |   |                        |   |                 |   |  |   |                                     |   |               |   |  |   |                                 |   |  |    |                         |    |                                   |    |                                 |    |                             |    |                          |    |                          |    |                        |    |                              |    |                              |    |                   |    |                                   |
| <b>SL.rtd</b>       | <b>Solutions Module trip: Drive mode has changed and Solutions Module parameter routing is now incorrect</b>   |  |                  |   |                   |   |                         |   |                        |   |                 |   |  |   |                                     |   |               |   |  |   |                                 |   |  |    |                         |    |                                   |    |                                 |    |                             |    |                          |    |                          |    |                        |    |                              |    |                              |    |                   |    |                                   |
| <b>215</b>          | Press reset.<br>If the trip persists, contact the supplier of the drive.   |  |                  |   |                   |   |                         |   |                        |   |                 |   |  |   |                                     |   |               |   |  |   |                                 |   |  |    |                         |    |                                   |    |                                 |    |                             |    |                          |    |                          |    |                        |    |                              |    |                              |    |                   |    |                                   |
| <b>SLX.tO</b>       | <b>Solutions Module slot X trip: Solutions Module watchdog timeout</b>   |  |                  |   |                   |   |                         |   |                        |   |                 |   |  |   |                                     |   |               |   |  |   |                                 |   |  |    |                         |    |                                   |    |                                 |    |                             |    |                          |    |                          |    |                        |    |                              |    |                              |    |                   |    |                                   |
| <b>201,206,211</b>  | Press reset.<br>If the trip persists, contact the supplier of the drive.   |  |                  |   |                   |   |                         |   |                        |   |                 |   |  |   |                                     |   |               |   |  |   |                                 |   |  |    |                         |    |                                   |    |                                 |    |                             |    |                          |    |                          |    |                        |    |                              |    |                              |    |                   |    |                                   |
| <b>t010</b>         | <b>User trip defined in 2<sup>nd</sup> processor Solutions Module code</b>   |  |                  |   |                   |   |                         |   |                        |   |                 |   |  |   |                                     |   |               |   |  |   |                                 |   |  |    |                         |    |                                   |    |                                 |    |                             |    |                          |    |                          |    |                        |    |                              |    |                              |    |                   |    |                                   |
| <b>10</b>           | SM-Applications program must be interrogated to find the cause of this trip  |  |                  |   |                   |   |                         |   |                        |   |                 |   |  |   |                                     |   |               |   |  |   |                                 |   |  |    |                         |    |                                   |    |                                 |    |                             |    |                          |    |                          |    |                        |    |                              |    |                              |    |                   |    |                                   |
| <b>t038</b>         | <b>User trip defined in 2<sup>nd</sup> processor Solutions Module code</b>   |  |                  |   |                   |   |                         |   |                        |   |                 |   |  |   |                                     |   |               |   |  |   |                                 |   |  |    |                         |    |                                   |    |                                 |    |                             |    |                          |    |                          |    |                        |    |                              |    |                              |    |                   |    |                                   |
| <b>38</b>           | SM-Applications program must be interrogated to find the cause of this trip  |  |                  |   |                   |   |                         |   |                        |   |                 |   |  |   |                                     |   |               |   |  |   |                                 |   |  |    |                         |    |                                   |    |                                 |    |                             |    |                          |    |                          |    |                        |    |                              |    |                              |    |                   |    |                                   |
| <b>t040 to t089</b> | <b>User trip defined in 2<sup>nd</sup> processor Solutions Module code</b>   |  |                  |   |                   |   |                         |   |                        |   |                 |   |  |   |                                     |   |               |   |  |   |                                 |   |  |    |                         |    |                                   |    |                                 |    |                             |    |                          |    |                          |    |                        |    |                              |    |                              |    |                   |    |                                   |
| <b>40 to 89</b>     | SM-Applications program must be interrogated to find the cause of this trip  |  |                  |   |                   |   |                         |   |                        |   |                 |   |  |   |                                     |   |               |   |  |   |                                 |   |  |    |                         |    |                                   |    |                                 |    |                             |    |                          |    |                          |    |                        |    |                              |    |                              |    |                   |    |                                   |
| <b>t099</b>         | <b>User trip defined in 2<sup>nd</sup> processor Solutions Module code</b>   |  |                  |   |                   |   |                         |   |                        |   |                 |   |  |   |                                     |   |               |   |  |   |                                 |   |  |    |                         |    |                                   |    |                                 |    |                             |    |                          |    |                          |    |                        |    |                              |    |                              |    |                   |    |                                   |
| <b>99</b>           | SM-Applications program must be interrogated to find the cause of this trip  |  |                  |   |                   |   |                         |   |                        |   |                 |   |  |   |                                     |   |               |   |  |   |                                 |   |  |    |                         |    |                                   |    |                                 |    |                             |    |                          |    |                          |    |                        |    |                              |    |                              |    |                   |    |                                   |
| <b>t101</b>         | <b>User trip defined in 2<sup>nd</sup> processor Solutions Module code</b>   |  |                  |   |                   |   |                         |   |                        |   |                 |   |  |   |                                     |   |               |   |  |   |                                 |   |  |    |                         |    |                                   |    |                                 |    |                             |    |                          |    |                          |    |                        |    |                              |    |                              |    |                   |    |                                   |
| <b>101</b>          | SM-Applications program must be interrogated to find the cause of this trip  |  |                  |   |                   |   |                         |   |                        |   |                 |   |  |   |                                     |   |               |   |  |   |                                 |   |  |    |                         |    |                                   |    |                                 |    |                             |    |                          |    |                          |    |                        |    |                              |    |                              |    |                   |    |                                   |
| <b>t111 to t160</b> | <b>User trip defined in 2<sup>nd</sup> processor Solutions Module code</b>   |  |                  |   |                   |   |                         |   |                        |   |                 |   |  |   |                                     |   |               |   |  |   |                                 |   |  |    |                         |    |                                   |    |                                 |    |                             |    |                          |    |                          |    |                        |    |                              |    |                              |    |                   |    |                                   |
| <b>111 to 160</b>   | SM-Applications program must be interrogated to find the cause of this trip  |  |                  |   |                   |   |                         |   |                        |   |                 |   |  |   |                                     |   |               |   |  |   |                                 |   |  |    |                         |    |                                   |    |                                 |    |                             |    |                          |    |                          |    |                        |    |                              |    |                              |    |                   |    |                                   |

| Trip                | Diagnosis  |
|---------------------|--|
| <b>t168 to t175</b> | <b>User trip defined in 2<sup>nd</sup> processor Solutions Module code</b>   |
| <b>168 to 175</b>   | SM-Applications program must be interrogated to find the cause of this trip  |
| <b>t216</b>         | <b>User trip defined in 2<sup>nd</sup> processor Solutions Module code</b>   |
| <b>216</b>          | SM-Applications program must be interrogated to find the cause of this trip  |
| <b>th</b>           | <b>Motor thermistor trip</b>   |
| <b>24</b>           | Check motor temperature<br>Check thermistor continuity<br>Set Pr 7.15 = VOLt and reset the drive to disable this function  |
| <b>thS</b>          | <b>Motor thermistor short circuit</b>  |
| <b>25</b>           | Check motor thermistor wiring<br>Replace motor / motor thermistor<br>Set Pr 7.15 = VOLt and reset the drive to disable this function   |
| <b>tunE*</b>        | <b>Autotune stopped before completion</b>  |
| <b>18</b>           | The drive has tripped out during the autotune<br>The red stop key has been pressed during the autotune<br>The secure disable signal (terminal 31) was active during the autotune procedure |
| <b>tunE1*</b>       | <b>The position feedback did not change or required speed could not be reached during the inertia test (see Pr 5.12)</b>   |
| <b>11</b>           | Ensure the motor is free to turn i.e. brake was released<br>Check feedback device wiring is correct<br>Check feedback parameters are set correctly<br>Check encoder coupling to motor      |
| <b>tunE2*</b>       | <b>Position feedback direction incorrect or motor could not be stopped during the inertia test (see Pr 5.12)</b>   |
| <b>12</b>           | Check motor cable wiring is correct<br>Check feedback device wiring is correct<br>Swap any two motor phases (closed loop vector only)  |
| <b>tunE3*</b>       | <b>Drive encoder commutation signals connected incorrectly or measured inertia out of range (see Pr 5.12)</b>  |
| <b>13</b>           | Check motor cable wiring is correct<br>Check feedback device U,V and W commutation signal wiring is correct  |
| <b>tunE4*</b>       | <b>Drive encoder U commutation signal fail during an autotune</b>  |
| <b>14</b>           | Check feedback device U phase commutation wires continuity<br>Replace encoder  |
| <b>tunE5*</b>       | <b>Drive encoder V commutation signal fail during an autotune</b>  |
| <b>15</b>           | Check feedback device V phase commutation wires continuity<br>Replace encoder  |
| <b>tunE6*</b>       | <b>Drive encoder W commutation signal fail during an autotune</b>  |
| <b>16</b>           | Check feedback device W phase commutation wires continuity<br>Replace encoder  |
| <b>tunE7*</b>       | <b>Motor number of poles set incorrectly</b>   |
| <b>17</b>           | Check lines per revolution for feedback device<br>Check the number of poles in Pr 5.11 is set correctly  |
| <b>Unid.P</b>       | <b>Power module unidentified trip</b>  |
| <b>110</b>          | Check all interconnecting cables between power modules<br>Ensure cables are routed away from electrical noise sources  |
| <b>UP ACC</b>       | <b>Onboard PLC program: cannot access Onboard PLC program file on drive</b>  |
| <b>98</b>           | Disable drive - write access is not allowed when the drive is enabled<br>Another source is already accessing Onboard PLC program - retry once other action is complete                     |
| <b>UP div0</b>      | <b>Onboard PLC program attempted divide by zero</b>  |
| <b>90</b>           | Check program  |
| <b>UP OFL</b>       | <b>Onboard PLC program variables and function block calls using more than the allowed RAM space (stack overflow)</b>   |
| <b>95</b>           | Check program  |
| <b>UP ovr</b>       | <b>Onboard PLC program attempted out of range parameter write</b>  |
| <b>94</b>           | Check program  |
| <b>UP PAr</b>       | <b>Onboard PLC program attempted access to a non-existent parameter</b>  |
| <b>91</b>           | Check program  |

| Trip                       | Diagnosis   |                            |                               |     |     |     |     |           |     |
|----------------------------|---|----------------------------|-------------------------------|-----|-----|-----|-----|-----------|-----|
| UP ro                      | Onboard PLC program attempted write to a read-only parameter  |                            |                               |     |     |     |     |           |     |
| 92                         | Check program   |                            |                               |     |     |     |     |           |     |
| UP So                      | Onboard PLC program attempted read of a write-only parameter  |                            |                               |     |     |     |     |           |     |
| 93                         | Check program   |                            |                               |     |     |     |     |           |     |
| UP udF                     | Onboard PLC program un-defined trip   |                            |                               |     |     |     |     |           |     |
| 97                         | Check program   |                            |                               |     |     |     |     |           |     |
| UP uSEr                    | Onboard PLC program requested a trip  |                            |                               |     |     |     |     |           |     |
| 96                         | Check program   |                            |                               |     |     |     |     |           |     |
| UV                         | DC bus under voltage threshold reached  |                            |                               |     |     |     |     |           |     |
| 1                          | Check AC supply voltage level<br><table border="1"> <thead> <tr> <th>Drive voltage rating (Vac)</th> <th>Under voltage threshold (Vdc)</th> </tr> </thead> <tbody> <tr> <td>200</td> <td>175</td> </tr> <tr> <td>400</td> <td>350</td> </tr> <tr> <td>575 &amp; 690</td> <td>435</td> </tr> </tbody> </table> | Drive voltage rating (Vac) | Under voltage threshold (Vdc) | 200 | 175 | 400 | 350 | 575 & 690 | 435 |
| Drive voltage rating (Vac) | Under voltage threshold (Vdc)   |                            |                               |     |     |     |     |           |     |
| 200                        | 175   |                            |                               |     |     |     |     |           |     |
| 400                        | 350   |                            |                               |     |     |     |     |           |     |
| 575 & 690                  | 435   |                            |                               |     |     |     |     |           |     |

\*If a tunE through tunE 7 trip occurs, then after the drive is reset the drive cannot be made to run unless it is disabled via the Secure Disable input (terminal 31), drive enable parameter (Pr 6.15) or the control word (Pr 6.42 and Pr 6.43).

Table 13-2 Serial communications look-up table

| No. | Trip     | No.        | Trip         | No.        | Trip         |
|-----|----------|------------|--------------|------------|--------------|
| 1   | UV       | 40 to 89   | t040 to t089 | 184        | C.FULL       |
| 2   | OV       | 90         | UP div0      | 185        | C.Acc        |
| 3   | OI.AC    | 91         | UP PAr       | 186        | C.rtg        |
| 4   | OI.br    | 92         | UP ro        | 187        | C.TyP        |
| 5   | PS       | 93         | UP So        | 188        | C.cPr        |
| 6   | Et       | 94         | UP ovr       | 189        | EnC1         |
| 7   | O.SPd    | 95         | UP OFL       | 190        | EnC2         |
| 8   | PS.10V   | 96         | UP uSEr      | 191        | EnC3         |
| 9   | PS.24V   | 97         | UP udF       | 192        | EnC4         |
| 10  | t010     | 98         | UP ACC       | 193        | EnC5         |
| 11  | tunE1    | 99         | t099         | 194        | EnC6         |
| 12  | tunE2    | 100        |              | 195        | EnC7         |
| 13  | tunE3    | 101        | t101         | 196        | EnC8         |
| 14  | tunE4    | 102        | Oht4.P       | 197        | EnC9         |
| 15  | tunE5    | 103        | Oibr.P       | 198        | EnC10        |
| 16  | tunE6    | 104        | OIAC.P       | 199        | DESt         |
| 17  | tunE7    | 105        | Oht2.P       | 200        | SL1.HF       |
| 18  | tunE     | 106        | OV.P         | 201        | SL1.tO       |
| 19  | It.br    | 107        | PH.P         | 202        | SL1.Er       |
| 20  | It.AC    | 108        | PS.P         | 203        | SL1.nF       |
| 21  | O.ht1    | 109        | OldC.P       | 204        | SL1.dF       |
| 22  | O.ht2    | 110        | Unid.P       | 205        | SL2.HF       |
| 23  | O.CtL    | 111 to 160 | t111 to t160 | 206        | SL2.tO       |
| 24  | th       | 161        | Enc11        | 207        | SL2.Er       |
| 25  | thS      | 162        | Enc12        | 208        | SL2.nF       |
| 26  | O.Ld1    | 163        | Enc13        | 209        | SL2.dF       |
| 27  | O.ht3    | 164        | Enc14        | 210        | SL3.HF       |
| 28  | cL2      | 165        | Enc15        | 211        | SL3.tO       |
| 29  | cL3      | 166        | Enc16        | 212        | SL3.Er       |
| 30  | SCL      | 167        | Enc17        | 213        | SL3.nF       |
| 31  | EEF      | 168 to 175 | t168 to t175 | 214        | SL3.dF       |
| 32  | PH       | 176        | EnP.Er       | 215        | SL.rtd       |
| 33  | rS       | 177        | C.boot       | 216        | t216         |
| 34  | PAd      | 178        | C.bUSY       | 217        | HF17         |
| 35  | CL.bit   | 179        | C.Chg        | 218        | HF18         |
| 36  | SAVE.Er  | 180        | C.OPtn       | 219        | HF19         |
| 37  | PSAVE.Er | 181        | C.RdO        | 220 to 232 | HF20 to HF32 |
| 38  | t038     | 182        | C.Err        |            |              |
| 39  | L.SYnC   | 183        | C.dAt        |            |              |

The trips can be grouped into the following categories. It should be noted that a trip can only occur when the drive is not tripped or is already tripped but with a trip with a lower priority number.

**Table 13-3 Trip categories**

| Priority | Category                               | Trips  | Comments  |
|----------|--|--|---|
| 1        | Hardware faults                        | HF01 to HF16   | These indicate fatal problems and cannot be reset. The drive is inactive after one of these trips and the display shows <b>HFxx</b> . The Drive Healthy relay opens and the serial comms will not function.                           |
| 2        | Non-resetable trips                    | HF17 to HF32, SL1.HF, SL2.HF, SL3.HF   | Cannot be reset. Requires the drive to be powered down.   |
| 3        | EEF trip                               | EEF  | Cannot be reset unless a code to load defaults is first entered in Pr <b>xx.00</b> or Pr <b>11.43</b> .   |
| 4        | SMARTCARD trips                        | C.boot, C.Busy, C.Chg, C.OPtn, C.RdO, C.Err, C.dat, C.FULL, C.Acc, C.rtg, C.TyP, C.cpr | Can be reset after 1.0s<br>SMARTCARD trips have priority 5 during power-up  |
| 4        | Encoder power supply trips             | PS.24V, EnC1   | Can be reset after 1.0s<br>These trips can only override the following priority 5 trips: EnC2 to EnC8 or Enc11 to Enc17   |
| 5        | Autotune                               | tunE, tunE1 to tunE7   | Can be reset after 1.0s, but the drive cannot be made to run unless it is disabled via the Secure Disable input (terminal 31), <i>Drive enable</i> (Pr <b>6.15</b> ) or the <i>Control word</i> (Pr <b>6.42</b> and Pr <b>6.43</b> ). |
| 5        | Normal trips with extended reset       | OI.AC, OI.Br, OIAC.P, OIBr.P, OldC.P   | Can be reset after 10.0s  |
| 5        | Normal trips                           | All other trips not included in this table   | Can be reset after 1.0s   |
| 5        | Non-important trips                    | th, thS, Old1, cL2, cL3, SCL   | If Pr <b>10.37</b> is 1 or 3 the drive will stop before tripping  |
| 5        | Phase loss                             | PH   | The drive attempts to stop before tripping  |
| 5        | Drive over-heat based on thermal model | O.ht3  | The drive attempts to stop before tripping, but if it does not stop within 10s the drive will automatically trip  |
| 6        | Self-resetting trips                   | UV   | Under voltage trip cannot be reset by the user, but is automatically reset by the drive when the supply voltage is with specification   |

Although the UV trip operates in a similar way to all other trips, all drive functions can still operate but the drive cannot be enabled. The following differences apply to the UV trip:

1. Power-down save user parameters are saved when UV trip is activated except when the main high voltage supply is not active (i.e. operating in Low Voltage DC Supply Mode, Pr **6.44** = 1).
2. The UV trip is self-resetting when the DC bus voltage rises above the drive restart voltage level. If another trip is active instead of UV at this point, the trip is not reset.
3. The drive can change between using the main high voltage supply and low voltage DC supply only when the drive is in the under voltage condition (Pr **10.16** = 1). The UV trip can only be seen as active if another trip is not active in the under voltage condition.
4. When the drive is first powered up a UV trip is initiated if the supply voltage is below the restart voltage level and another trip is not active. This does not cause save power down save parameters to be saved at this point.

## 13.2 Alarm indications

In any mode an alarm flashes alternately with the data displayed on the 2<sup>nd</sup> row when one of the following conditions occur. If action is not taken to eliminate any alarm except "Autotune" the drive may eventually trip.

**Table 13-4 Alarm indications**

| Lower display   | Description   |
|---|---|
| <b>br.rS</b>  | Braking resistor overload   |
| Braking resistor I <sup>2</sup> t accumulator (Pr <b>10.37</b> ) in the drive has reached 75.0% of the value at which the drive will trip and the braking IGBT is active.   |   |
| <b>Hot</b>  | Heatsink or control board or inverter IGBT over temperature alarms are active |
| <ul style="list-style-type: none"> <li>• The drive heatsink temperature has reached a threshold and the drive will trip O.ht2 if the temperature continues to rise (see the O.ht2 trip).</li> </ul> Or <ul style="list-style-type: none"> <li>• The ambient temperature around the control PCB is approaching the over temperature threshold (see the O.CtL trip).</li> </ul> |   |
| <b>OVLd</b>   | Motor overload  |
| The motor I <sup>2</sup> t accumulator in the drive has reached 75% of the value at which the drive will be tripped and the load on the drive is >100%  |   |

### 13.3 Status indications

Table 13-5 Status indications

| Upper display     | Description  | Drive output stage |
|-------------------|--|--------------------|
| <b>ACt</b>        | Regeneration mode active<br>The regen unit is enabled and synchronised to the supply.  | Enabled            |
| <b>ACUU</b>       | AC Supply loss<br>The drive has detected that the AC supply has been lost and is attempting to maintain the DC bus voltage by decelerating the motor.                          | Enabled            |
| <b>*Auto tunE</b> | Autotune in progress<br>The autotune procedure has been initialised. **'Auto' and 'tunE' will flash alternatively on the display.  | Enabled            |
| <b>dc</b>         | DC applied to the motor<br>The drive is applying DC injection braking.   | Enabled            |
| <b>dEC</b>        | Decelerating<br>The drive is decelerating the motor.   | Enabled            |
| <b>inh</b>        | Inhibit<br>The drive is inhibited and cannot be run. The drive enable signal is not applied to terminal 31 or Pr 6.15 is set to 0.   | Disabled           |
| <b>PLC</b>        | Onboard PLC program is running<br>An Onboard PLC program is fitted and running. The lower display will flash 'PLC' once every 10s.   | Not applicable     |
| <b>POS</b>        | Positioning<br>The drive is positioning/orientating the motor shaft.   | Enabled            |
| <b>rdY</b>        | Ready<br>The drive is ready to be run.   | Disabled           |
| <b>run</b>        | Running<br>The drive is running.   | Enabled            |
| <b>SCAn</b>       | Scanning<br>OL> The drive is searching for the motor frequency when synchronising to a spinning motor.<br>Regen> The drive is enabled and is synchronising to the line.        | Enabled            |
| <b>StoP</b>       | Stop or holding zero speed<br>The drive is holding zero speed.<br>Regen> The drive is enabled but the AC voltage is too low, or the DC bus voltage is still rising or falling. | Enabled            |
| <b>triP</b>       | Trip condition<br>The drive has tripped and is no longer controlling the motor. The trip code appears on the lower display.  | Disabled           |

Table 13-6 Solutions Module and SMARTCARD status indications at power-up

| Lower display  | Description  |
|----------------|--|
| <b>boot</b>    | A parameter set is being transferred from the SMARTCARD to the drive during power-up. For further information, please refer to section 9.2.4 <i>Booting up from the SMARTCARD on every power up (Pr 11.42 = boot (4))</i> on page 153. |
| <b>cArd</b>    | The drive is writing a parameter set to the SMARTCARD during power-up. For further information, please refer to section 9.2.3 <i>Auto saving parameter changes (Pr 11.42 = Auto (3))</i> on page 153.                                  |
| <b>IoAding</b> | The drive is writing information to a Solutions Module.  |

### 13.4 Displaying the trip history

The drive retains a log of the last 10 trips that have occurred in Pr 10.20 to Pr 10.29 and the corresponding multi-module drive module number (Pr 6.49 = 1) or the trip time (Pr 6.49 = 0) for each trip in Pr 10.41 to Pr 10.51. The time of the trip is recorded from the powered-up clock (if Pr 6.28 = 0) or from the run time clock (if Pr 6.28 = 1).

Pr 10.20 is the most recent trip, or the current trip if the drive is in a trip condition (with the module number or trip time stored in Pr 10.41 and Pr 10.42). Pr 10.29 is the oldest trip (with the module number or trip time stored in Pr 10.51). Each time a new trip occurs, all the parameters move down one, such that the current trip (and time) is stored in Pr 10.20 (and Pr 10.41 to Pr 10.42) and the oldest trip (and time) is lost out of the bottom of the log.

If any parameter between Pr 10.20 and Pr 10.29 inclusive is read by serial communications, then the trip number in Table 13-1 *Trip indications* on page 276 is the value transmitted.

## 14 UL Listing Information

The Control Techniques UL file number is E171230. Confirmation of UL listing can be found on the UL website: [www.ul.com](http://www.ul.com).

### 14.1 Common UL information

#### Conformity

The drive conforms to UL listing requirements only when the following are observed:

- The drive is installed in a type 1 enclosure, or better, as defined by UL50
- The ambient temperature does not exceed 40°C (104°F) when the drive is operating
- The terminal tightening torques specified in section 3.14.2 *Terminal sizes and torque settings* on page 65.
- If the drive control stage is supplied by an external power supply (+24V), the external power supply must be a UL Class 2 power supply

#### Motor overload protection

The drive provides motor overload protection. The default overload protection level is no higher than 150% of full-load current (FLC) of the drive in open loop mode and no higher than 175% of full-load current (FLC) of the drive in closed loop vector or servo modes. It is necessary for the motor rated current to be entered into Pr **0.46** (or Pr **5.07**) for the protection to operate correctly. The protection level may be adjusted below 150% if required. Refer to section 8.3 *Current limits* on page 148 for more information. The drive also provides motor thermal protection. Refer to section 8.4 *Motor thermal protection* on page 148.

#### Overspeed Protection

The drive provides overspeed protection. However, it does not provide the level of protection afforded by an independent high integrity overspeed protection device.

### 14.2 Power dependant UL information

#### 14.2.1 Unidrive SP size 1 to 6

##### Conformity

The drive conforms to UL listing requirements only when the following is observed:

##### Fuses

###### Size 1 to 3

- The correct UL-listed fast acting fuses (class CC up to 30A and class J above 30A), e.g. Bussman Limitron KTK series, Gould Amp-Trap ATM series or equivalent, are used in the AC supply. The drive does not comply with UL if MCBs are used in place of fuses.

For further details on fusing, refer to in Table 4-3 and Table 4-4 on page 76.

###### Size 4 to 6

- The UL-listed Ferraz HSJ (High speed J class) fuses are used in the AC supply. The drive does not comply with UL if any other fuses or MCBs are used in place of those stated.

For further details on fusing, refer to Table 4-5 on page 77.

##### Field wiring

###### Size 1 to 4

- Class 1 60/75°C (140/167°F) copper wire only is used in the installation

###### Size 5 and 6

- Class 1 75°C (167°F) copper wire only is used in the installation

##### Field wiring connectors

###### Sizes 4 to 6

- UL listed wire connectors are used for terminating power circuit field wiring, e.g. IlSCO TA series

### 14.3 AC supply specification

The Unidrive SP is suitable for use in a circuit capable of delivering not more than 100,000rms symmetrical Amperes at 264Vac rms maximum (200V drives), 528Vac rms maximum (400V drives) or 600Vac rms maximum (575V and 690V drives).

### 14.4 Maximum continuous output current

The drive models are listed as having the maximum continuous output currents (FLC) shown in Table 14-1, Table 14-2, Table 14-3 and Table 14-4 (see Chapter 12 *Technical Data* on page 257 for details).

**Table 14-1 Maximum continuous output current (200V drives)**

| Model  | FLC (A) | Model  | FLC (A) |
|--------|---------|--------|---------|
| SP1201 | 5.2     | SP3201 | 42      |
| SP1202 | 6.8     | SP3202 | 54      |
| SP1203 | 9.6     | SP4201 | 68      |
| SP1204 | 11      | SP4202 | 80      |
| SP2201 | 15.5    | SP4203 | 104     |
| SP2202 | 22      |        |         |
| SP2203 | 28      |        |         |

**Table 14-2 Maximum continuous output current (400V drives)**

| Model  | FLC (A) | Model  | FLC (A) |
|--------|---------|--------|---------|
| SP1401 | 2.8     | SP3401 | 35      |
| SP1402 | 3.8     | SP3402 | 43      |
| SP1403 | 5.0     | SP3403 | 56      |
| SP1404 | 6.9     | SP4401 | 68      |
| SP1405 | 8.8     | SP4402 | 83      |
| SP1406 | 11      | SP4403 | 104     |
| SP2401 | 15.3    | SP5401 | 138     |
| SP2402 | 21      | SP5402 | 168     |
| SP2403 | 29      | SP6401 | 202     |
| SP2404 | 29      | SP6402 | 236     |

**Table 14-3 Maximum continuous output current (575V drives)**

| Model  | FLC (A) | Model  | FLC (A) |
|--------|---------|--------|---------|
| SP3501 | 5.4     | SP3505 | 16      |
| SP3502 | 6.1     | SP3506 | 22      |
| SP3503 | 8.3     | SP3507 | 27      |
| SP3504 | 11      |        |         |

**Table 14-4 Maximum continuous output current (690V drives)**

| Model  | FLC (A) | Model  | FLC (A) |
|--------|---------|--------|---------|
| SP4601 | 22      | SP5601 | 84      |
| SP4602 | 27      | SP5602 | 99      |
| SP4603 | 36      | SP6601 | 125     |
| SP4604 | 43      | SP6602 | 144     |
| SP4605 | 52      |        |         |
| SP4606 | 62      |        |         |

### 14.5 Safety label

The safety label supplied with the connectors and mounting brackets must be placed on a fixed part inside the drive enclosure where it can be seen clearly by maintenance personnel for UL compliance.

The label clearly states "CAUTION Risk of Electric Shock Power down unit 10 minutes before removing cover".

### 14.6 UL listed accessories

- SM-Universal Encoder Plus
- SM-Resolver
- SM-Encoder Plus
- 15-way D-type converter
- SM-I/O Plus
- SM-Applications
- SM-Applications Lite
- SM-SLM
- SM-PROFIBUS-DP
- SM-DeviceNet
- SM-INTERBUS
- SM-CAN
- SM-CANopen
- SM-Keypad
- SM-Keypad Plus

# List of figures

|             |   |    |             |  |    |
|-------------|---|----|-------------|--|----|
| Figure 2-1  | Features of the wall mounted drive .....  | 17 | Figure 3-32 | Through-panel mounting the size 3 drive .....  | 44 |
| Figure 2-2  | Features of the free standing cubicle drive .....   | 18 | Figure 3-33 | Through-panel mounting the size 4 drive .....  | 44 |
| Figure 2-3  | Typical drive rating labels .....   | 19 | Figure 3-34 | Through-panel mounting the size 5 drive .....  | 45 |
| Figure 2-4  | Options available with Unidrive SP .....  | 20 | Figure 3-35 | Through-panel mounting the size 6 drive .....  | 46 |
| Figure 2-5  | Accessories supplied with size 1 .....  | 22 | Figure 3-36 | Size 4, 5 and 6 mounting bracket .....   | 47 |
| Figure 2-6  | Accessories supplied with size 2 .....  | 23 | Figure 3-37 | Orientation of the size 4, 5 and 6 mounting<br>bracket .....                         | 47 |
| Figure 2-7  | Accessories supplied with size 3 .....  | 23 | Figure 3-38 | Location of top surface mounting brackets<br>for size 5 and 6 .....                  | 47 |
| Figure 2-8  | Accessories supplied with size 4 .....  | 24 | Figure 3-39 | Incomer shell / applications cubicle<br>dimensions .....                             | 48 |
| Figure 2-9  | Accessories supplied with size 5 .....  | 24 | Figure 3-40 | Size 8 free standing cubicle drive dimensions .                                      | 49 |
| Figure 2-10 | Accessories supplied with size 6 .....  | 24 | Figure 3-41 | Size 9 free standing cubicle drive dimensions .                                      | 50 |
| Figure 3-1  | Removing a free standing cubicle drive<br>from packaging .....  | 25 | Figure 3-42 | Enclosure layout .....   | 51 |
| Figure 3-2  | Lifting the free standing cubicle drive .....   | 26 | Figure 3-43 | Enclosure having front, sides and top panels<br>free to dissipate heat .....         | 52 |
| Figure 3-3  | Location and identification of terminal covers ...  | 27 | Figure 3-44 | Example of IP54 (NEMA 12) rating layout .....  | 53 |
| Figure 3-4  | Location and identification of terminal covers<br>for free standing cubicle drives .....                                  | 28 | Figure 3-45 | Fitting of IP54 insert for size 1 .....  | 54 |
| Figure 3-5  | Removing the size 1 terminal covers .....   | 29 | Figure 3-46 | Fitting of IP54 insert for size 2 .....  | 54 |
| Figure 3-6  | Removing the size 2 terminal covers .....   | 29 | Figure 3-47 | Footprint mounting the EMC filter .....  | 55 |
| Figure 3-7  | Removing the size 3 terminal covers .....   | 29 | Figure 3-48 | Bookcase mounting the EMC filter .....   | 55 |
| Figure 3-8  | Removing the size 4, 5 and 6 terminal<br>covers (size 4 illustrated) .....  | 30 | Figure 3-49 | Size 4 to 6 mounting of EMC filter .....   | 55 |
| Figure 3-9  | Removing the size 8 terminal covers from<br>the free standing cubicle drive .....   | 30 | Figure 3-50 | Size 1 external EMC filter .....   | 56 |
| Figure 3-10 | Removing the size 9 terminal covers from<br>the free standing cubicle drive .....   | 31 | Figure 3-51 | Size 2 external EMC filter .....   | 56 |
| Figure 3-11 | Preparation for baying the incomer /<br>applications cubicle .....  | 32 | Figure 3-52 | Size 3 external EMC filter .....   | 57 |
| Figure 3-12 | Preparation for baying the size 8 free<br>standing drive .....  | 32 | Figure 3-53 | Size 4 and 5 external EMC filter .....   | 58 |
| Figure 3-13 | Preparation for baying the size 9 free<br>standing drive (slave and master) .....   | 32 | Figure 3-54 | Size 6 external EMC filter .....   | 59 |
| Figure 3-14 | Baying of cubicles .....  | 33 | Figure 3-55 | Through-panel mounting cut-out details for<br>size 1 .....                           | 60 |
| Figure 3-15 | Baying the incomer shell / applications<br>cubicle to a free standing cubicle drive .....                                 | 34 | Figure 3-56 | Through-panel mounting cut-out details for<br>size 2 .....                           | 60 |
| Figure 3-16 | Baying the size 9 master and slave .....  | 34 | Figure 3-57 | Fitting the heatsink mounted braking<br>resistor on size 1 .....                     | 60 |
| Figure 3-17 | Fitting the parallel cable from a size 9<br>master to slave .....   | 35 | Figure 3-58 | Connecting the brake resistor on a surface<br>mounted size 1 .....                   | 60 |
| Figure 3-18 | Removing the finger-guard break-outs .....  | 36 | Figure 3-59 | Connecting the brake resistor on a<br>through-panel mounted size 1 .....             | 61 |
| Figure 3-19 | Removing the DC terminal cover break-outs ....  | 36 | Figure 3-60 | Removing the baffle plate on a size 2 .....  | 61 |
| Figure 3-20 | Fitting fuses to the size 8 and 9 free<br>standing cubicle drives .....   | 36 | Figure 3-61 | Modifying the fan baffle on a size 2 .....   | 61 |
| Figure 3-21 | Removing the cable gland plate from the<br>size 8 and 9 free standing cubicle drive for<br>“glanding off” the cable ..... | 37 | Figure 3-62 | Fitting the heatsink mounted braking resistor<br>on a size 2 .....                   | 61 |
| Figure 3-22 | Fitting and removal of a Solutions Module .....   | 38 | Figure 3-63 | Connecting the brake resistor on a surface<br>mounted size 2 .....                   | 62 |
| Figure 3-23 | Fitting and removal of a keypad .....   | 38 | Figure 3-64 | Connecting the brake resistor on a<br>through-panel mounted size 2 .....             | 62 |
| Figure 3-24 | Surface mounting the size 1 drive .....   | 39 | Figure 3-65 | Locations of the power and ground<br>terminals on wall mounted drives .....          | 63 |
| Figure 3-25 | Surface mounting the size 2 drive .....   | 39 | Figure 3-66 | Locations of the power and ground terminals<br>on free standing cubicle drives ..... | 64 |
| Figure 3-26 | Surface mounting the size 3 drive .....   | 40 | Figure 4-1  | Unidrive SP size 1 power connections .....   | 66 |
| Figure 3-27 | Surface mounting the size 4 drive .....   | 40 | Figure 4-2  | Unidrive SP size 2 power connections .....   | 67 |
| Figure 3-28 | Surface mounting the size 5 drive .....   | 41 | Figure 4-3  | Unidrive SP size 3 power connections .....   | 67 |
| Figure 3-29 | Surface mounting the size 6 drive .....   | 42 | Figure 4-4  | Unidrive SP size 4, 5 and 6 power connections  | 68 |
| Figure 3-30 | Through-panel mounting the size 1 drive .....   | 43 | Figure 4-5  | Unidrive SP size 8 free standing cubicle drive<br>power connections .....            | 69 |
| Figure 3-31 | Through-panel mounting the size 2 drive .....   | 43 |             |  |    |

|             |   |    |              |   |     |
|-------------|---|----|--------------|---|-----|
| Figure 4-6  | Unidrive SP size 9 free standing cubicle drive power connections .....        | 70 | Figure 4-45  | Size 4 and 5 low voltage DC mode enable connections .....   | 99  |
| Figure 4-7  | Unidrive SP size 2 ground connections .....                                   | 71 | Figure 4-46  | Size 6 low voltage DC mode enable connections .....   | 99  |
| Figure 4-8  | Unidrive SP size 3 ground connections .....                                   | 71 | Figure 4-47  | Start / stop control EN954-1 category B - replacement of contactor .....                                  | 101 |
| Figure 4-9  | Unidrive SP size 4, 5 and 6 ground connections .....                          | 71 | Figure 4-48  | Category 3 interlock using electromechanical safety contactors .....                                      | 101 |
| Figure 4-10 | Unidrive SP size 8 and 9 free standing cubicle ground connections .....       | 72 | Figure 4-49  | Category 3 interlock using Secure Disable with protected wiring .....                                     | 101 |
| Figure 4-11 | Location of the size 6 heatsink fan supply connections .....                  | 73 | Figure 4-50  | Use of contactor and relay to avoid the need for protected wiring .....                                   | 101 |
| Figure 4-12 | Size 6 heatsink fan supply connections .....                                  | 73 | Figure 5-1   | SM-Keypad .....   | 102 |
| Figure 4-13 | Location of size 8 and 9 free standing cubicle drive 24V power supply .....   | 74 | Figure 5-2   | SM-Keypad Plus .....  | 102 |
| Figure 4-14 | SP8414 24V power supply .....   | 74 | Figure 5-3   | Display modes .....   | 103 |
| Figure 4-15 | Cable construction influencing the capacitance .....                          | 79 | Figure 5-4   | Mode examples .....   | 103 |
| Figure 4-16 | Preferred chain connection for multiple motors .....                          | 79 | Figure 5-5   | Parameter navigation .....  | 103 |
| Figure 4-17 | Alternative connection for multiple motors .....                              | 80 | Figure 5-6   | Menu structure .....  | 104 |
| Figure 4-18 | Typical protection circuit for a braking resistor .....                       | 82 | Figure 5-7   | Menu 0 Cloning .....  | 104 |
| Figure 4-19 | Fitting of grounding clamp (size 1 and 2) .....                               | 83 | Figure 6-1   | Menu 0 logic diagram .....  | 112 |
| Figure 4-20 | Fitting of grounding clamp (size 3) .....                                     | 83 | Figure 6-2   | Fixed and variable V/f characteristics .....  | 115 |
| Figure 4-21 | Fitting of grounding bracket (sizes 1 to 6) .....                             | 83 | Figure 7-1   | Minimum connections to get the motor running in any operating mode for sizes 1 to 6 .....                 | 126 |
| Figure 4-22 | Grounding link bracket in its surface mount position (as supplied) .....      | 84 | Figure 7-2   | Minimum connections to get the motor running in any operating mode for free standing cubicle drives ..... | 128 |
| Figure 4-23 | Grounding link bracket folded up into its through- panel mount position ..... | 84 | Figure 8-1   | Motor thermal protection (Heavy Duty) .....   | 148 |
| Figure 4-24 | Removal of internal EMC filter (size 1 to 3) .....                            | 84 | Figure 8-2   | Motor thermal protection (Normal Duty) .....  | 148 |
| Figure 4-25 | Removal of internal EMC filter (sizes 4 to 6) .....                           | 84 | Figure 8-3   | Torque and rated voltage against speed .....  | 149 |
| Figure 4-26 | General EMC enclosure layout showing ground connections .....                 | 85 | Figure 9-1   | Installation of the SMARTCARD .....   | 151 |
| Figure 4-27 | Drive cable clearances .....  | 86 | Figure 9-2   | Basic SMARTCARD operation .....   | 151 |
| Figure 4-28 | Feedback cable, twisted pair .....  | 86 | Figure 10-1  | Unidrive SP Onboard PLC program scheduling .....  | 157 |
| Figure 4-29 | Feedback cable connections .....  | 87 | Figure 10-2  | Programming options for Unidrive SP .....   | 158 |
| Figure 4-30 | Supply and ground cable clearance (size 1 to 3) .....                         | 88 | Figure 11-1  | Menu 1 logic diagram .....  | 168 |
| Figure 4-31 | Supply and ground cable clearance (size 4 to 6) .....                         | 88 | Figure 11-2  | Menu 2 logic diagram .....  | 172 |
| Figure 4-32 | Sensitive signal circuit clearance .....                                      | 89 | Figure 11-3  | Menu 3 Open-loop logic diagram .....  | 175 |
| Figure 4-33 | Grounding the drive, motor cable shield and filter .....                      | 89 | Figure 11-4  | Menu 3 Closed loop logic diagram .....  | 176 |
| Figure 4-34 | Grounding the motor cable shield .....  | 89 | Figure 11-5  | Menu 4 Open loop logic diagram .....  | 180 |
| Figure 4-35 | Shielding requirements of optional external braking resistor .....            | 89 | Figure 11-6  | Menu 4 Closed-loop vector logic diagram .....   | 181 |
| Figure 4-36 | Grounding of signal cable shields using the grounding bracket .....           | 90 | Figure 11-7  | Menu 4 Servo logic diagram .....  | 182 |
| Figure 4-37 | Connecting the motor cable to a terminal block in the enclosure .....         | 90 | Figure 11-8  | Menu 5 Open-loop logic diagram .....  | 184 |
| Figure 4-38 | Connecting the motor cable to an isolator switch .....                        | 90 | Figure 11-9  | Menu 5 Closed-loop logic diagram .....  | 186 |
| Figure 4-39 | Surge suppression for digital and unipolar inputs and outputs .....           | 91 | Figure 11-10 | Menu 6 logic diagram .....  | 189 |
| Figure 4-40 | Surge suppression for analogue and bipolar inputs and outputs .....           | 91 | Figure 11-11 | Menu 7 logic diagram .....  | 191 |
| Figure 4-41 | Location of the RJ45 serial comms connector .....                             | 91 | Figure 11-12 | Menu 8 logic diagram .....  | 194 |
| Figure 4-42 | Default terminal functions .....  | 93 | Figure 11-13 | Menu 9 logic diagram .....  | 198 |
| Figure 4-43 | Location of encoder connector .....   | 96 | Figure 11-14 | Menu 12 logic diagram .....   | 203 |
| Figure 4-44 | Location of the size 4 to 6 low voltage DC mode enable connections .....      | 99 | Figure 11-15 | Menu 12 logic diagram (continued) .....   | 204 |
|             |   |    | Figure 11-16 | Open-loop brake function .....  | 205 |
|             |   |    | Figure 11-17 | Open-loop brake sequence .....  | 205 |
|             |   |    | Figure 11-18 | Closed-loop brake function .....  | 206 |
|             |   |    | Figure 11-19 | Closed-loop brake sequence .....  | 206 |
|             |   |    | Figure 11-20 | Menu 13 Open-loop logic diagram .....   | 208 |
|             |   |    | Figure 11-21 | Menu 13 Closed-loop logic diagram .....   | 210 |

|              |  |     |
|--------------|--|-----|
| Figure 11-22 | Menu 14 Logic diagram .....  | 214 |
| Figure 11-23 | Location of Solutions Module slots and<br>their corresponding menu numbers ..... | 217 |
| Figure 11-24 | SM-Universal Encoder Plus logic diagram .....                                    | 218 |
| Figure 11-25 | SM-Resolver logic diagram .....  | 222 |
| Figure 11-26 | SM-Encoder Plus logic diagram .....  | 224 |
| Figure 11-27 | SM-I/O Plus analogue logic diagram .....   | 226 |
| Figure 11-28 | SM-I/O Plus digital logic diagram 1 .....  | 227 |
| Figure 11-29 | SM-I/O Plus digital logic diagram 2 .....  | 228 |
| Figure 11-30 | SM-I/O Lite & SM-I/O Timer digital I/O logic<br>diagram .....                    | 230 |
| Figure 11-31 | SM-I/O Lite & SM-I/O Timer analogue I/O<br>logic diagram .....                   | 231 |
| Figure 11-32 | SM-I/O Timer real time clock logic diagram .....                                 | 231 |
| Figure 11-33 | SM-PELV digital I/O logic diagram .....  | 233 |
| Figure 11-34 | SM-PELV digital input logic diagram .....  | 234 |
| Figure 11-35 | SM-PELV relay logic diagram .....  | 234 |
| Figure 11-36 | SM-PELV analog input logic diagram .....   | 235 |
| Figure 11-37 | SM-PELV analog output logic diagram .....  | 235 |
| Figure 11-38 | SM-I/O 120V digital input logic diagram .....                                    | 237 |
| Figure 11-39 | SM-I/O 120V digital I/O logic diagram .....                                      | 238 |
| Figure 11-40 | SM-SLM logic diagram .....   | 242 |
| Figure 11-41 | Digital input connections when Pr <b>6.04</b> is<br>set to 0 to 3 .....          | 254 |
| Figure 13-1  | Keypad status modes .....  | 275 |
| Figure 13-2  | Location of the status LED .....   | 275 |

## List of tables

|            |   |     |            |   |     |
|------------|---|-----|------------|---|-----|
| Table 2-1  | 200V Drive ratings (200V to 240V $\pm 10\%$ ) .....   | 12  | Table 7-1  | Minimum control connection requirements for each control mode .....   | 124 |
| Table 2-2  | 400V Drive ratings (380V to 480V $\pm 10\%$ ) .....   | 12  | Table 7-2  | Minimum control connection requirements for each mode of operation .....  | 124 |
| Table 2-3  | 575V Drive ratings (500V to 575V $\pm 10\%$ ) .....   | 14  | Table 7-3  | Parameters required for feedback device set-up .....  | 134 |
| Table 2-4  | 690V Drive ratings (500V to 690V $\pm 10\%$ ) .....   | 14  | Table 7-4  | Restrictions of drive encoder lines per revolution with software version V01.06.01 and later .....                  | 137 |
| Table 2-5  | Typical overload limits for size 1 to 5 .....   | 15  | Table 7-5  | Restrictions of drive encoder lines per revolution with software version V01.06.00 and earlier .....                | 137 |
| Table 2-6  | Typical overload limits for size 6 and above .....  | 15  | Table 8-1  | Available switching frequencies for drives .....  | 149 |
| Table 2-7  | Encoders compatible with Unidrive SP .....  | 16  | Table 8-2  | Available switching frequencies for free standing cubicle drives .....  | 149 |
| Table 2-8  | Solutions Module identification .....   | 20  | Table 8-3  | Sample rates for various control tasks at each switching frequency .....  | 149 |
| Table 2-9  | Keypad identification .....   | 22  | Table 9-1  | SMARTCARD data blocks .....   | 152 |
| Table 3-1  | Mounting brackets .....   | 47  | Table 9-2  | SMARTCARD codes .....   | 152 |
| Table 3-2  | Environment considerations .....  | 53  | Table 9-3  | Key to parameter table coding .....   | 154 |
| Table 3-3  | Power losses from the front of the drive when through-panel mounted .....                           | 53  | Table 9-4  | Trip conditions .....   | 155 |
| Table 3-4  | Drive EMC filter details (size 1 to 6) .....  | 55  | Table 9-5  | SMARTCARD status indications .....  | 156 |
| Table 3-5  | Free standing cubicle drive EMC filter details (size 8 and 9) .....                                 | 55  | Table 11-1 | Menu descriptions .....   | 160 |
| Table 3-6  | Drive control and relay terminal data .....   | 65  | Table 11-2 | Key to parameter table coding .....   | 160 |
| Table 3-7  | Wall mounted drive power terminal data .....  | 65  | Table 11-3 | Feature look-up table .....   | 161 |
| Table 3-8  | Free standing cubicle drive terminal data .....   | 65  | Table 11-4 | Definition of parameter ranges & variable maximums .....  | 164 |
| Table 3-9  | Schaffner external EMC filter terminal data .....   | 65  | Table 11-5 | Maximum motor rated current for drives .....  | 166 |
| Table 3-10 | Epcos external EMC Filter terminal data .....   | 65  | Table 11-6 | Maximum motor rated current for free standing cubicle drives .....  | 167 |
| Table 4-1  | Behaviour of the drive in the event of a motor circuit ground (earth) fault with an IT supply ..... | 72  | Table 11-7 | Defaults for Pr <b>10.30</b> and Pr <b>10.31</b> .....  | 201 |
| Table 4-2  | Supply fault current used to calculate maximum input currents .....                                 | 75  | Table 11-8 | Active reference .....  | 248 |
| Table 4-3  | Size 1 to 3 input current, fuse and cable size ratings (European) .....                             | 75  | Table 12-1 | Maximum permissible continuous output current @ 40°C (104°F) ambient for wall mounted drives .....                  | 257 |
| Table 4-4  | Size 1 to 3 input current, fuse and cable size ratings (USA) .....                                  | 76  | Table 12-2 | Maximum permissible continuous output current @ 40°C (104°F) ambient for free standing cubicle drives .....         | 258 |
| Table 4-5  | Size 4 and larger input current, fuse and cable size ratings .....                                  | 77  | Table 12-3 | Maximum permissible continuous output current @ 40°C (104°F) ambient with IP54 insert and standard fan fitted ..... | 258 |
| Table 4-6  | Size 8 and 9 fuses .....  | 77  | Table 12-4 | Maximum permissible continuous output current @ 50°C (122°F) ambient for wall mounted drives .....                  | 259 |
| Table 4-7  | Maximum motor cable lengths (200V drives) .....   | 78  | Table 12-5 | Maximum permissible continuous output current @ 50°C (122°F) ambient for free standing cubicle mounted drives ..... | 260 |
| Table 4-8  | Maximum motor cable lengths (400V drives) .....   | 78  | Table 12-6 | Losses @ 40°C (104°F) ambient for wall mounted drives .....   | 261 |
| Table 4-9  | Maximum motor cable lengths (575V drives) .....   | 78  | Table 12-7 | Losses @ 40°C (104°F) ambient for free standing cubicle drives .....  | 262 |
| Table 4-10 | Maximum motor cable lengths (690V drives) .....   | 79  | Table 12-8 | Losses @ 40°C (104°F) ambient with IP54 insert and standard fan fitted .....  | 262 |
| Table 4-11 | Braking transistor turn on voltage .....  | 80  | Table 12-9 | Losses @ 50°C (122°F) ambient for wall mounted drives .....   | 263 |
| Table 4-12 | Heatsink mounted braking resistor data .....  | 81  |            |   |     |
| Table 4-13 | Minimum resistance values and peak power rating for the braking resistor at 40°C (104°F) .....      | 81  |            |   |     |
| Table 4-14 | Unidrive SP and EMC filter cross reference .....  | 83  |            |   |     |
| Table 4-15 | Second environment emission compliance .....  | 87  |            |   |     |
| Table 4-16 | Connection details for RJ45 connector .....   | 91  |            |   |     |
| Table 4-17 | Isolated serial comms lead details .....  | 91  |            |   |     |
| Table 4-18 | The Unidrive SP control connections consist of: .....   | 92  |            |   |     |
| Table 4-19 | Encoder types .....   | 96  |            |   |     |
| Table 4-20 | Drive encoder connector details .....   | 97  |            |   |     |
| Table 4-21 | Feedback resolution based on frequency and voltage level .....                                      | 98  |            |   |     |
| Table 5-1  | Alarm indications .....   | 105 |            |   |     |
| Table 5-2  | Status indications .....  | 105 |            |   |     |
| Table 5-3  | Solutions Module and SMARTCARD status indications on power-up .....                                 | 105 |            |   |     |

|             |   |            |   |
|-------------|---|------------|---|
| Table 12-10 | Losses @ 50°C (122°F) ambient for free standing cubicle drives .....264                           | Table 14-4 | Maximum continuous output current (690V drives) ..... 292 |
| Table 12-11 | Power losses from the front of the drive when through-panel mounted .....264                      |            |   |
| Table 12-12 | IP Rating degrees of protection .....265  |            |   |
| Table 12-13 | NEMA enclosure ratings .....265   |            |   |
| Table 12-14 | Acoustic noise data for wall mounted drives ...266  |            |   |
| Table 12-15 | Acoustic noise data for free standing cubicle drives .....266                                     |            |   |
| Table 12-16 | Overall wall mounted drive dimensions .....266  |            |   |
| Table 12-17 | Overall free standing cubicle mounted drive dimensions .....266                                   |            |   |
| Table 12-18 | Overall wall mounted drive weights .....266   |            |   |
| Table 12-19 | Overall free standing cubicle drive weights ...266  |            |   |
| Table 12-20 | Supply fault current used to calculate maximum input currents .....267                            |            |   |
| Table 12-21 | Size 1 to 3 input current, fuse and cable size ratings .....267                                   |            |   |
| Table 12-22 | Size 4, 5 and 6 input current, fuse and cable size ratings .....268                               |            |   |
| Table 12-23 | Size 8 and 9 fuses .....268   |            |   |
| Table 12-24 | Maximum motor cable lengths (200V drives) .268  |            |   |
| Table 12-25 | Maximum motor cable lengths (400V drives) .269  |            |   |
| Table 12-26 | Maximum motor cable lengths (575V drives) .269  |            |   |
| Table 12-27 | Maximum motor cable lengths (690V drives) .269  |            |   |
| Table 12-28 | Minimum resistance values and peak power rating for the braking resistor at 40°C (104°F) .....269 |            |   |
| Table 12-29 | Drive control and relay terminal data .....270  |            |   |
| Table 12-30 | Wall mounted drive power terminal data .....270   |            |   |
| Table 12-31 | Free standing cubicle drive terminal data .....270  |            |   |
| Table 12-32 | Immunity compliance .....270  |            |   |
| Table 12-33 | Size 1 emission compliance .....271   |            |   |
| Table 12-34 | Size 2 emission compliance .....271   |            |   |
| Table 12-35 | Size 3 (200V and 400V only) emission compliance .....271  |            |   |
| Table 12-36 | Size 4 (400V only) emission compliance .....271   |            |   |
| Table 12-37 | Unidrive SP and EMC filter cross reference ...272   |            |   |
| Table 12-38 | Free standing cubicle drive EMC filter details (size 8 and 9) .....272                            |            |   |
| Table 12-39 | Optional external EMC filter details .....273   |            |   |
| Table 12-40 | Optional external EMC filter dimensions .....274  |            |   |
| Table 12-41 | Optional external EMC Filter terminal data ....274  |            |   |
| Table 13-1  | Trip indications .....276   |            |   |
| Table 13-2  | Serial communications look-up table .....289  |            |   |
| Table 13-3  | Trip categories .....290  |            |   |
| Table 13-4  | Alarm indications .....290  |            |   |
| Table 13-5  | Status indications .....291   |            |   |
| Table 13-6  | Solutions Module and SMARTCARD status indications at power-up .....291                            |            |   |
| Table 14-1  | Maximum continuous output current (200V drives) .....292  |            |   |
| Table 14-2  | Maximum continuous output current (400V drives) .....292  |            |   |
| Table 14-3  | Maximum continuous output current (575V drives) .....292  |            |   |

# Index

## Symbols

|                           |    |
|---------------------------|----|
| +10V user output .....    | 93 |
| +24V external input ..... | 93 |
| +24V user output .....    | 94 |

## Numerics

|                 |    |
|-----------------|----|
| 0V common ..... | 93 |
|-----------------|----|

## A

|  |   |
|--|---|
| AC supply contactor .....                | 78  |
| AC supply requirements .....             | 72  |
| Acceleration .....                       | 109, 114, 130, 131, 132, 133, 141, 144, 174 |
| Access .....                             | 26  |
| Access Level .....                       | 106   |
| Accuracy .....                           | 265   |
| Acoustic noise .....                     | 266   |
| Advanced menus .....                     | 104   |
| Advanced parameters .....                | 160   |
| Air-flow in a ventilated enclosure ..... | 52  |
| Alarm .....                              | 290   |
| Alarm Indications .....                  | 290   |
| Altitude .....                           | 265   |
| Analogue input 2 .....                   | 94  |
| Analogue input 3 .....                   | 94  |
| Analogue output 1 .....                  | 94  |
| Analogue output 2 .....                  | 94  |
| Autotune .....                           | 138, 141, 144, 146                          |

## B

|                               |     |
|-------------------------------|-----|
| Basic requirements .....      | 124 |
| Braking .....                 | 80  |
| Braking resistor values ..... | 269 |

## C

|                                      |               |
|--------------------------------------|---------------|
| Cable clearances .....               | 86            |
| Cable lengths (maximum) .....        | 268           |
| Cable size ratings .....             | 266           |
| Cable types and lengths .....        | 78            |
| Cautions .....                       | 10            |
| CD ROM file contents .....           | 22            |
| Closed loop vector mode .....        | 15            |
| Control connections .....            | 92            |
| Control terminal specification ..... | 93            |
| Cooling .....                        | 26            |
| Cooling method .....                 | 264           |
| CTSoft .....                         | 134           |
| Current limits .....                 | 148           |
| Current loop gains .....             | 141, 144, 146 |
| Current ratings .....                | 257           |

## D

|                                      |   |
|--------------------------------------|---|
| DC bus paralleling .....             | 73  |
| DC bus voltage .....                 | 80, 165, 249, 252, 253  |
| Deceleration .....                   | 80, 109, 114, 116, 130, 131, 132, 133, 141, 144, 174, 246, 249, 252 |
| Defaults (restoring parameter) ..... | 106   |
| Delta motor operation .....          | 80  |
| Derating .....                       | 257   |
| Destination parameter .....          | 92  |
| Diagnostics .....                    | 275   |
| Digital I/O 1 .....                  | 95  |
| Digital I/O 2 .....                  | 95  |
| Digital I/O 3 .....                  | 95  |
| Digital Input 1 .....                | 95  |
| Digital Input 2 .....                | 95  |
| Digital Input 3 .....                | 95  |
| Dimensions (overall) .....           | 266   |
| Display .....                        | 102   |
| Display messages .....               | 105   |
| Drive enable .....                   | 95  |
| Drive features .....                 | 16  |

## E

|  |             |
|--|-------------|
| Electrical Installation .....                          | 66          |
| Electrical safety .....                                | 26          |
| Electrical terminals .....                             | 63          |
| Electromagnetic compatibility (EMC) .....              | 26, 82, 270 |
| EMC - Compliance with generic emission standards ..... | 88          |
| EMC - General requirements .....                       | 85          |
| EMC - Variations in the wiring .....                   | 89          |
| EMC filter dimensions (external, overall) .....        | 274         |
| EMC filter torque settings (external) .....            | 274         |
| EMC filters (optional external) .....                  | 272         |
| Emission .....   | 270         |
| EN61800-3 (standard for Power Drive Systems) .....     | 87          |
| Enclosure .....  | 51          |
| Enclosure Layout .....                                 | 51          |
| Enclosure sizing .....                                 | 51          |
| Encoder connections .....                              | 86, 96      |
| Encoder feedback limits .....                          | 149         |
| Encoder types .....                                    | 96          |
| Environmental protection .....                         | 26          |
| External EMC filter .....                              | 55          |

## F

|  |     |
|--|-----|
| Feedback device cable screening .....            | 86  |
| Field weakening (constant power) operation ..... | 149 |
| Fieldbus module category parameters .....        | 240 |
| Fire protection .....                            | 26  |
| Fixed V/F mode .....                             | 15  |
| Fuse ratings .....                               | 266 |
| Fuse types .....                                 | 78  |

## G

|                          |        |
|--------------------------|--------|
| Getting Started .....    | 102    |
| Ground connections ..... | 78, 85 |
| Ground leakage .....     | 82     |
| Ground terminals .....   | 63     |
| Grounding bracket .....  | 83     |
| Grounding clamp .....    | 83     |

|  |         |  |                    |
|--|---------|--|--------------------|
| <b>H</b>                                     |         | <b>M</b>   |                    |
| Hazardous areas .....                        | 26      | Maximum speed / frequency .....  | 150                |
| Heatsink mounted braking resistor .....      | 60, 80  | Mechanical Installation .....  | 25                 |
| High speed operation .....                   | 149     | Menu 0 .....   | 104, 109           |
| Humidity .....                               | 264     | Menu 01 - Frequency / speed reference .....                              | 168                |
| <b>I</b>                                     |         | Menu 02 - Ramps .....  | 172                |
| I/O module category parameters .....         | 226     | Menu 03 - Slave frequency, speed feedback and speed control .....        | 175                |
| Input current ratings .....                  | 266     | Menu 04 - Torque and current control .....                               | 180                |
| Input inductor calculation .....             | 73      | Menu 05 - Motor control .....  | 184                |
| Internal EMC filter .....                    | 84      | Menu 06 - Sequencer and clock .....                                      | 189                |
| IP Rating (Ingress protection) .....         | 53, 265 | Menu 07 - Analogue I/O .....   | 191                |
| Isolator switch .....                        | 90      | Menu 08 - Digital I/O .....  | 194                |
| Items supplied with the drive .....          | 22      | Menu 09 - Programmable logic, motorised pot and binary sum .....         | 198                |
| <b>K</b>                                     |         | Menu 10 - Status and trips .....   | 201                |
| Keypad and display - fitting / removal ..... | 38      | Menu 11 - General drive set-up .....                                     | 202                |
| Keypad operation .....                       | 102     | Menu 12 - Threshold detectors and variable selectors .....               | 203                |
| <b>L</b>                                     |         | Menu 13 - Position control .....   | 208                |
| Line reactors .....                          | 72, 264 | Menu 14 - User PID controller .....                                      | 214                |
|  |         | Menu 15, 16 and 17 - Solutions Module set-up .....                       | 217                |
|  |         | Menu 18 - Application menu 1 .....                                       | 245                |
|  |         | Menu 19 - Application menu 2 .....                                       | 245                |
|  |         | Menu 20 - Application menu 3 .....                                       | 245                |
|  |         | Menu 21 - Second motor parameters .....                                  | 246                |
|  |         | Menu 22 - Additional Menu 0 set-up .....                                 | 247                |
|  |         | Menu structure .....   | 103                |
|  |         | Minimum connections to get the motor running in any operating mode ..... | 126, 128           |
|  |         | Mode parameter .....   | 92                 |
|  |         | Model number .....   | 15                 |
|  |         | Motor (running the motor) .....  | 124                |
|  |         | Motor cable - interruptions .....  | 90                 |
|  |         | Motor isolator-switch .....  | 90                 |
|  |         | Motor map parameters .....   | 138                |
|  |         | Motor number of poles .....  | 138, 140, 143, 146 |
|  |         | Motor rated current .....  | 138, 140, 143, 146 |
|  |         | Motor rated current (maximum) .....                                      | 148                |
|  |         | Motor rated frequency .....  | 138, 140, 143      |
|  |         | Motor rated power factor .....   | 138, 140, 143      |
|  |         | Motor rated speed .....  | 138, 140, 143      |
|  |         | Motor rated speed autotune .....   | 141, 144           |
|  |         | Motor rated voltage .....  | 138, 140, 143      |
|  |         | Motor requirements .....   | 264                |
|  |         | Motor thermal protection .....   | 148                |
|  |         | Motor winding voltage .....  | 79                 |
|  |         | Mounting methods .....   | 39                 |
|  |         | Multiple motors .....  | 79                 |
|  |         | <b>N</b>   |                    |
|  |         | Nameplate description .....  | 19                 |
|  |         | NEMA rating .....  | 53, 265            |
|  |         | Notes .....  | 10                 |
|  |         | <b>O</b>   |                    |
|  |         | Onboard PLC .....  | 157                |
|  |         | Open loop mode .....   | 15                 |
|  |         | Open loop vector mode .....  | 15                 |
|  |         | Operating mode (changing) .....  | 106, 124           |
|  |         | Operating modes .....  | 15                 |
|  |         | Optimisation .....   | 138                |
|  |         | Options .....  | 20                 |
|  |         | Output contactor .....   | 80                 |
|  |         | Output frequency .....   | 265                |

**P**

|  |         |
|--|---------|
| Parameter access level .....                       | 106     |
| Parameter ranges .....                             | 164     |
| Parameter security .....                           | 106     |
| Planning the installation .....                    | 26      |
| Position feedback .....                            | 124     |
| Position feedback module category parameters ..... | 218     |
| Power dissipation .....                            | 261     |
| Power ratings .....                                | 81, 257 |
| Power terminals .....                              | 63      |
| Precision reference Analogue input 1 .....         | 93      |
| Product information .....                          | 11      |

**Q**

|                                 |     |
|---------------------------------|-----|
| Quadratic V/F mode .....        | 15  |
| Quick Start commissioning ..... | 130 |
| Quick start commissioning ..... | 134 |
| Quick start connections .....   | 124 |

**R**

|   |         |
|---|---------|
| Ratings .....                             | 11, 75  |
| Reactor current ratings .....             | 73, 264 |
| Relay contacts .....                      | 95      |
| Residual current device (RCD) .....       | 82      |
| Resistances (minimum) .....               | 81      |
| Resolution .....                          | 265     |
| RJ45 connector - connection details ..... | 91      |
| Routine maintenance .....                 | 65      |

**S**

|   |               |
|---|---------------|
| Safety Information .....  | 10, 25        |
| Saving parameters .....   | 106           |
| Sealed enclosure - sizing .....   | 51            |
| SECURE DISABLE .....  | 100           |
| Serial comms lead .....   | 91            |
| Serial communications connections .....   | 91            |
| Serial communications look-up table .....   | 289           |
| Serial communications port isolation .....  | 91            |
| Servo .....   | 15            |
| Single line descriptions .....  | 109           |
| Slip compensation .....   | 139           |
| SMARTCARD operation .....   | 151, 157      |
| SMARTCARD trips .....   | 155           |
| Solutions Module .....  | 217           |
| Solutions Module - fitting / removal .....  | 38            |
| Speed feedback .....  | 124           |
| Speed loop gains .....  | 142, 145, 147 |
| Speed range .....   | 265           |
| Star motor operation .....  | 80            |
| Start up time .....   | 265           |
| Starts per hour .....   | 265           |
| Status .....  | 105, 291      |
| Status Indications .....  | 291           |
| Storage .....   | 265           |
| Supply requirements .....   | 264           |
| Supply types .....  | 72            |
| Surface mounting the drive .....  | 39            |
| Surge immunity of control circuits - long cables and connections outside a building ..... | 90            |
| Surge suppression for analogue and bipolar inputs and outputs .....                       | 91            |
| Surge suppression for digital and unipolar inputs and outputs .....                       | 91            |
| Switching frequency .....   | 149, 150      |
| SYPTLite .....  | 157           |

**T**

|   |         |
|---|---------|
| Technical data .....                                      | 257     |
| Temperature .....   | 264     |
| Terminal block in the enclosure .....                     | 90      |
| Terminal cover removal .....                              | 26      |
| Terminal sizes .....                                      | 65      |
| Thermal protection circuit for the braking resistor ..... | 82      |
| Through-panel mounting the drive .....                    | 43      |
| Torque settings .....                                     | 65, 270 |
| Trip .....  | 275     |
| Trip categories .....                                     | 290     |
| Trip History .....  | 291     |
| Trip Indications .....                                    | 275     |

**U**

|                              |     |
|------------------------------|-----|
| UL Listing Information ..... | 292 |
| User Security .....          | 107 |

**V**

|                         |     |
|-------------------------|-----|
| Variable maximums ..... | 164 |
| Ventilation .....       | 53  |
| Vibration .....         | 265 |
| Voltage mode .....      | 139 |

**W**

|                |     |
|----------------|-----|
| Warnings ..... | 10  |
| Weights .....  | 266 |



# Training

## Invest in YOUR Future

Control Techniques offers a unique combination of drive, servo and software training solutions all designed to maximise the productivity of your machine or process. Train in a safe and dedicated environment with highly qualified and experienced trainers. For a great mix of classroom and practical 'hands-on' teaching experience contact your local Drive Centre.



### AC Drive Maintenance

Basic Electrical Technology (Part 1 & Part 2)

Commander SK Simple AC Drive

High Speed Communications (Profibus, DeviceNet, CNet etc.)

DC Drive Maintenance

E-Series Drive

Fan & Pump Duty Assist Control Application Software

Flying Shear Control Application Software

Mentor II DC Digital Drives

MC Motion Controller, M'Ax Servo & MultiAx

Motion Controller with Control Techniques Drives

Commander SE Simple AC Drive

Servo Drives & Systems

Introduction to Servo Drives & Systems

MD29 / UD70 Application Programming

Unidrive Classic Universal AC Drive

Unidrive  Universal AC Drive



Winder Control Application Software

Train at our dedicated, fully equipped Training Centre based in the heart of Mid Wales, alternatively training can be arranged on site at your own facilities or at your local Drive Centre. To contact your local Drive Centre visit [www.controltechniques.com](http://www.controltechniques.com)



Control Techniques Visitor and Training Centre, Unit 5 St. Giles Technology Park, Newtown, Powys SY16 3AJ, UK  
Tel: +44 (0)1686 612900 Fax: +44 (0)1686 612999 [www.controltechniques.com](http://www.controltechniques.com) Email: [training@controltechniques.com](mailto:training@controltechniques.com)



**0471-0000-11**