

User Guide

UD50

Additional I/O
small option module
for Unidrive

Part Number: 0447-0046

Issue Number: 3

General Information

The manufacturer accepts no liability for any consequences resulting from inappropriate, negligent or incorrect installation or adjustment of the operating parameters of the equipment or from mismatching the Drive with the motor.

The contents of this Guide are believed to be correct at the time of printing. In the interests of a commitment to a policy of continuous development and improvement, the manufacturer reserves the right to change the specification of the product or its performance, or the contents of this Guide, without notice.

All rights reserved. No part of this Guide may be reproduced or transmitted in any form or by any means, electrical or mechanical including photocopying, recording or by any information storage or retrieval system, without permission in writing from the publisher.

Use within the European Union, etc

The following information applies where the end use of the Drive is within the European Union, the European Economic Area, or other regions which have implemented Directives of the European Council or equivalent measures.

The Drive complies with the Low Voltage Directive 73/23/EEC.

The installer is responsible for ensuring that the equipment into which the Drive is incorporated complies with all relevant Directives.

The complete equipment must comply with the EMC Directive 89/336/EEC.

If the Drive is incorporated into a machine, the manufacturer is responsible for ensuring that the machine complies with the Machinery Directive 89/392/EEC. In particular, the electrical equipment should generally comply with European Harmonised standard EN60204-1.

Copyright © May 1998 Control Techniques Drives Ltd
Author: RFD
Issue Code: 50nu3
Issue Date: May 1998

Contents

Chapter

1	Introduction	1
2	Safety Information	2
3	Installing the UD50	5
4	Descriptions of the Terminals	7
4.1	Functions	8
5	Related Parameters	9
5.1	Introduction	9
5.2	Key	9
5.3	Descriptions of the parameters	12

Appendix

A	Specifications	A-1
A.1	Relays 2, 3 (terminals 40, 41, 42)	A-1
A.2	Digital inputs F10, F11, F12 (terminals 44, 45, 46)	A-1
A.3	Digital inputs/outputs F7, F8, F9 (terminals 48, 49, 50)	A-2
A.4	Analog inputs 4 & 5 (terminals 51, 52)	A-3
A.5	Analog output 3 (terminal 54)	A-3

Declaration of Conformity

Control Techniques plc,
The Gro, Newtown, Powys, UK, SY16 3BE

UD50 Additional I/O small option module
--

The option module for AC variable speed drive products shown above has been designed and manufactured in accordance with the following European harmonised, national and international standards:

EN60249	Base materials for printed circuits
IEC326-1	Printed boards: general information for the specification writer
IEC326-5	Printed boards: specification for single- and double-sided printed boards with plated-through holes
IEC326-6	Printed boards: specification for multilayer printed boards
IEC664-1	Insulation co-ordination for equipment within low-voltage systems: principles, requirements and tests
EN60529	Degrees of protection provided by enclosures (IP code)
UL94	Flammability rating of plastic materials
UL508C	Standard for power conversion equipment
EN50081-1	Generic emission standard for the residential, commercial and light industrial environment
EN50081-2	Generic emission standard for the industrial environment
EN50082-2	Generic immunity standard for the industrial environment
EN61800-3	Adjustable speed electrical power drive systems – Part 3: EMC product standard including specific test methods

This product complies with the Low Voltage Directive 73/23/EEC, the Electromagnetic Compatibility (EMC) Directive 89/336/EEC and the CE Marking Directive 93/68/EEC.



W. Drury
Technical Director
Newtown
Date: 27th April 1998

These electronic Drive products are intended to be used with appropriate motors, controllers, electrical protection components and other equipment to form complete end products or systems. Compliance with safety and EMC regulations depends upon installing and configuring Drives correctly, including using the specified input filters. The Drives must be installed only by professional assemblers who are familiar with requirements for safety and EMC. The assembler is responsible for ensuring that the end product or system complies with all the relevant laws in the country where it is to be used. Refer to the Unidrive Installation Guide for guidelines on installation. A *Unidrive EMC Data Sheet* is also available giving detailed EMC information.

UD50 User Guide
Issue code: 50nu3

1 Introduction

The UD50 *small option module* increases the I/O capability of the Unidrive by adding the following to the existing I/O in the Drive:

Quantity	Function
2	Relay contacts
3	Digital input
3	Digital port that can be programmed as an input or output
2	Analog voltage input
1	Analog voltage output

All the I/O in the UD50 is programmable for function and signal processing.

The UD50 must be fitted in the *small option module* bay of the Unidrive. All connections to the Drive are made by a multi-way connector. Connections from external equipment are made to a two-part 16-way screw-terminal block on the UD50.

2 Safety Information



2.1

Warnings, Cautions and Notes

A **Warning** contains information which is essential for avoiding a safety hazard.

A **Caution** contains information which is necessary for avoiding a risk of damage to the product or other equipment.

A **Note** contains information which helps to ensure correct operation of the product.

2.2

Electrical safety – general warning

The voltages used in the Drive can cause severe electric shock and/or burns, and could be lethal. Extreme care is necessary at all times when working with or adjacent to the Drive.

Specific warnings are given at the relevant places in this User Guide.

The installation must comply with all relevant safety legislation in the country of use.

The Drive contains capacitors that remain charged to a potentially lethal voltage after the AC supply has been disconnected. If the Drive has been energized, the AC supply must be isolated at least ten minutes before work may continue.

2.3

System design

The Drive is intended as a component for professional incorporation into complete equipment or systems. If installed incorrectly the Drive may present a safety hazard. The Drive uses high voltages and currents, carries a high level of stored electrical energy, and is used to control mechanical equipment which can cause injury.

Close attention is required to the electrical installation and the system-design to avoid hazards either in normal operation or in the event of equipment malfunction. System-design, installation, commissioning and maintenance must be carried out by personnel who have the necessary training and experience. They must read this safety information and this User Guide carefully.

To ensure mechanical safety, additional safety devices such as electro-mechanical interlocks may be required. The Drive must not be used in a safety-critical application without additional high-integrity protection against hazards arising from a malfunction.

2.4 Environmental limits

Instructions in the *Unidrive Installation Guide* regarding transport, storage, installation and use of Drives must be complied with, including the specified environmental limits. Drives must not be subjected to excessive physical force.

2.5 Compliance with regulations

The installer is responsible for complying with all relevant regulations, such as national wiring regulations, accident prevention regulations and electromagnetic compatibility (EMC) regulations. Particular attention must be given to the cross-sectional areas of conductors, the selection of fuses or other protection, and protective earth (ground) connections.

The *Unidrive Installation Guide* contains instructions for achieving compliance with specific EMC standards.

Within the European Union, all machinery in which this product is used must comply with the following directives:

89/392/EEC: Safety of Machinery

89/336/EEC: Electromagnetic Compatibility

2.6 Safety of personnel

The STOP function of the Drive does not remove dangerous voltages from the output of the Drive or from any external option unit.

The Stop and Start controls or electrical inputs of the Drive should not be relied upon to ensure safety of personnel. If a safety hazard could exist from unexpected starting of the Drive, an interlock that electrically isolates the Drive from the AC supply should be installed to prevent the motor being inadvertently started.

Careful consideration must be given to the functions of the Drive which might result in a hazard, either through their intended functions (eg. Auto-start) or through incorrect operation due to a fault or trip (eg. stop/start, forward/reverse, maximum speed).

Under certain conditions, the Drive can suddenly discontinue control of the motor. If the load on the motor could cause the motor speed to be increased (eg. hoists and cranes), a separate method of braking and stopping the motor should be used (eg. a mechanical brake).

Before connecting the AC supply to the Drive, it is important that you understand the operating controls and their operation. If in doubt, do not adjust the Drive. Damage may occur, or lives put at risk. Carefully follow the instructions in this User Guide.

Before making adjustments to the Drive, ensure all personnel in the area are warned. Make notes of all adjustments that are made.

2.7 Risk analysis

In any application where a malfunction of the Drive could lead to damage, loss of life or injury, a risk analysis must be carried out, and where necessary, further measures taken to reduce the risk. This would normally be an appropriate form of independent safety back-up system using simple electro-mechanical components.

2.8 Signal connections

The control circuits are isolated from the power circuits in the Drive by basic insulation only, as specified in IEC664–1. The installer must ensure that the external control circuits are insulated from human contact by at least one layer of insulation rated for use at the AC supply voltage.

If the control circuits are to be connected to other circuits classified as Safety Extra Low Voltage (SELV) (eg. to a personal computer), an additional isolating barrier must be included in order to maintain the SELV classification.

2.9 Adjusting parameters

Some parameters have a profound effect on the operation of the Drive. They must not be altered without careful consideration of the impact on the controlled system. Measures must be taken to prevent unwanted changes due to error or tampering.

3 Installing the UD50



Warning

Before using the following procedure, refer to the Warnings at the beginning of Chapter 2 *Installing the Drive* in the Unidrive Installation Guide.

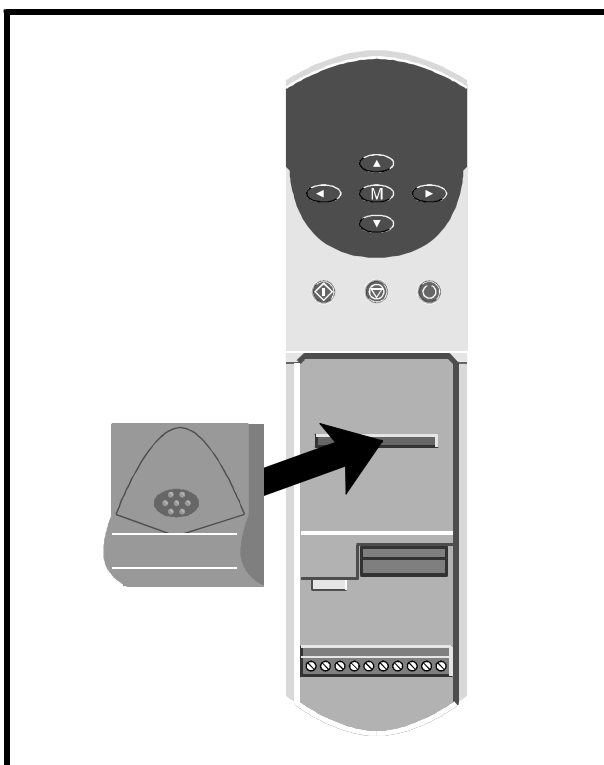

Figure 1 *Installing the UD50 in the Unidrive*

- 1 Before installing the UD50 in the Unidrive, ensure the AC supply has been disconnected from the Drive for at least 10 minutes.
- 2 Check that the exterior of the UD50 is not damaged, and that the multi-way connector is free from dirt and debris. Do not install a damaged or dirty UD50 in the Drive.
- 3 Remove the terminal cover from the Drive (for removal instructions, see *Installing the Drive and RFI filter* in Chapter 2 of the Unidrive Installation Guide).

- 4 Position the multi-way connector on the rear of the UD50 over the connector in the Drive (see Figure 1), and press on the thumb pad to push the UD50 into place.
- 5 Re-fit the terminal cover to the Drive.
- 6 Connect the AC supply to the Drive.
- 7 Set parameter **.00** at **149** to unlock security.
- 8 Check that Menu-16 parameters are now available.
- 9 Check that parameter **16.01** is set at **1**.

If the checks in steps 8 and 9 fail, either the UD50 is not fully inserted, or it is faulty.

4 Descriptions of the Terminals

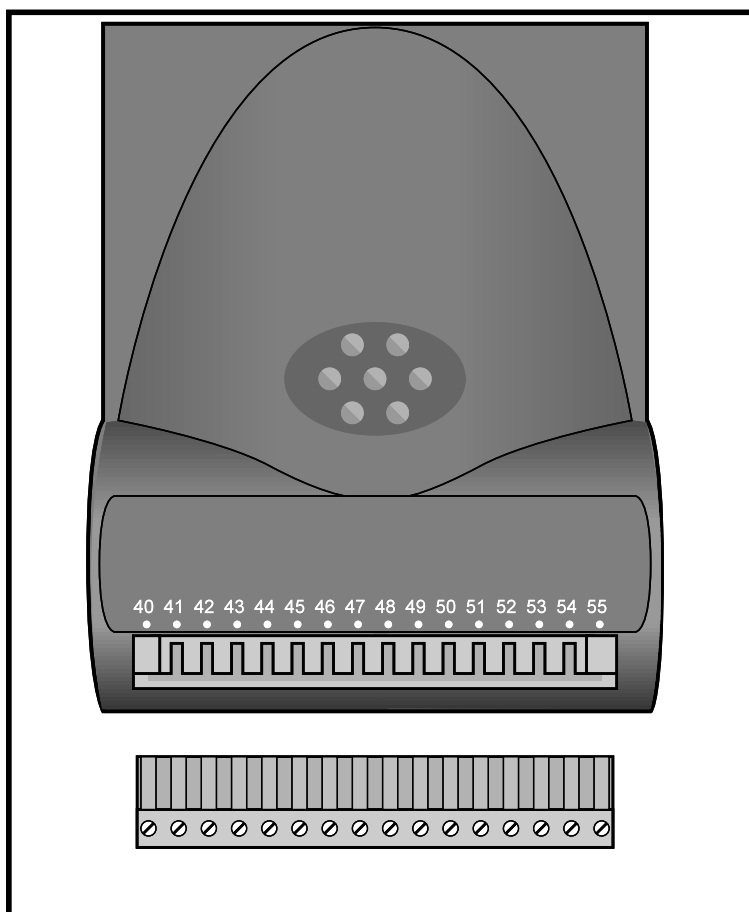

Figure 2 Location of the two-part terminal block

4.1 Functions

Terminal	Function
40	Relay 2 contact
41	Relay 3 contact
42	Relay common
43	0V common (digital)
44	Digital input F10
45	Digital input F11
46	Digital input F12
47	0V common (digital)
48	Digital input/output F7
49	Digital input/output F8
50	Digital input/output F9
51	Analog input 4
52	Analog input 5
53	0V common (analog)
54	Analog output 3
55	0V common (analog)

5 Related Parameters

5.1 Introduction

The parameters listed in this chapter are used for programming and monitoring the I/O of the UD50. Refer to the Unidrive User Guide for programming instructions.



Before attempting to adjust any parameters, refer to the Warnings and Notes at the beginning of Chapter 3 *Setting up the Drive* in the Unidrive User Guide.

5.2 Key

Type of parameter



RO Read-only



RW Read-write

...select Select from two settings

...enable Make or allow a function to operate

...indicator The value can only be read

Limitations of use

R The Drive must be reset for a new value to take effect.

P Protected parameter; the parameter cannot be used as the destination parameter for a programmable input.

Range

Bi Variable parameter having bipolar value range.

Uni Variable parameter having unipolar value range.

Bit Bit parameter

Symbols

⇨ Default value

⇄ Range of values

~ Indicates a range of values
(in the case of bit parameters, ~ indicates *or*).

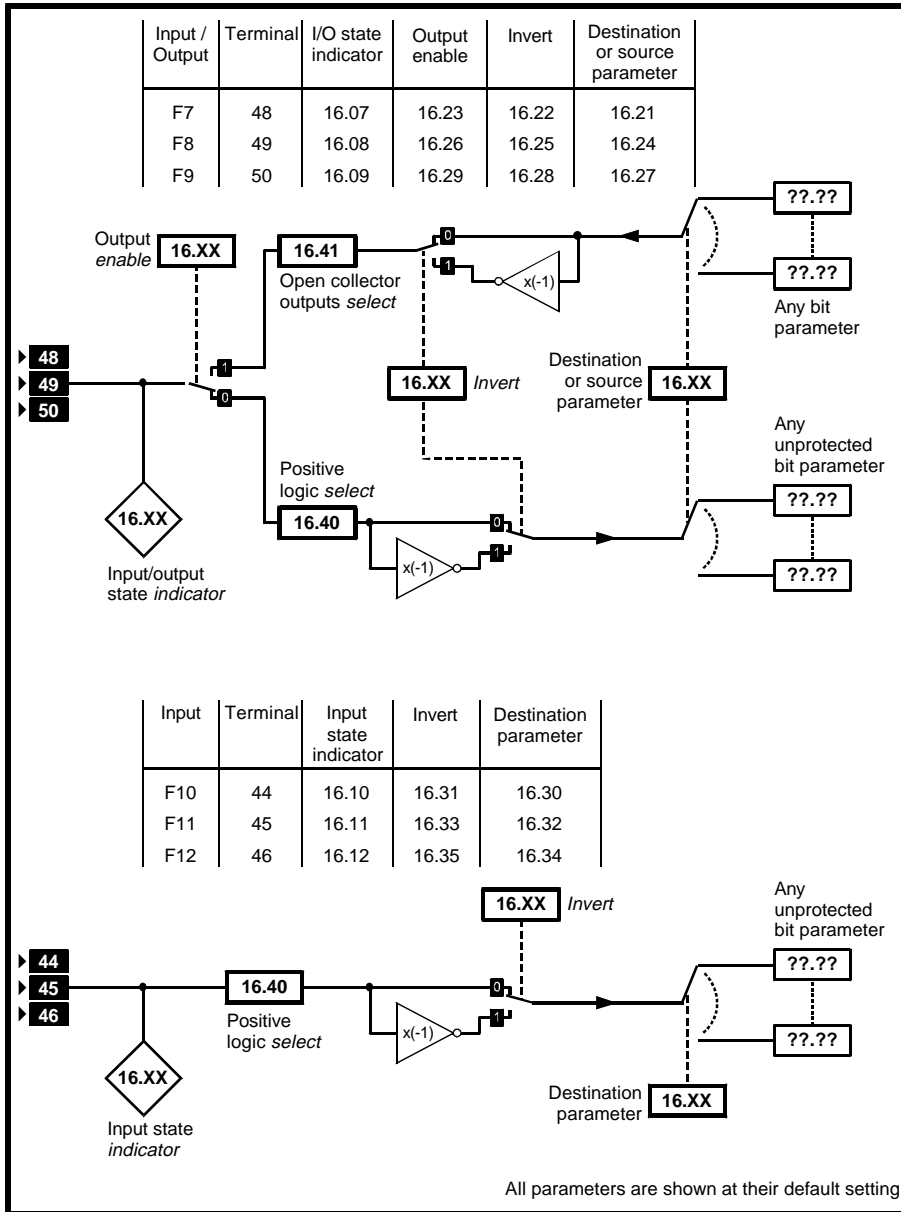

Figure 3 Logic diagram of the digital I/O

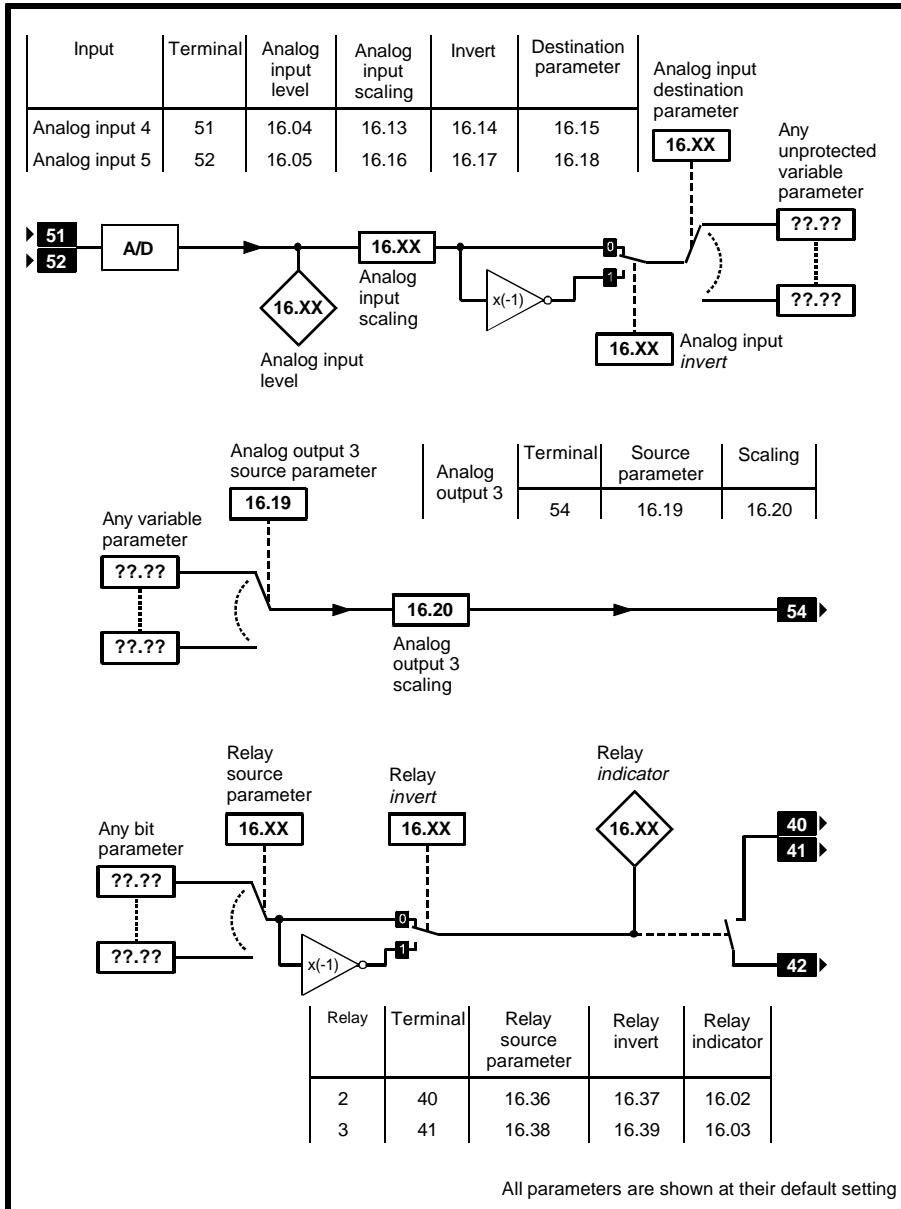

Figure 4 Logic diagram of the analog I/O and relays

5.3 Descriptions of the parameters

16.01 Option module fitted code

⇅	0 ~ 100	⇒			RO	Uni			P
---	---------	---	--	--	----	-----	--	--	---

16.01 indicates the type of small option module that is fitted in the Drive, as follows:

- 0 No small option module
- 1 UD50 Additional I/O
- 2 UD51 Second encoder interface
- 3 UD53 Resolver interface
- 4 UD52 sin-cos encoder

16.02 Relay 2 indicator

16.03 Relay 3 indicator

⇅	0 ~ 1	⇒			RO	Bit			P
---	-------	---	--	--	----	-----	--	--	---

16.02 and **16.03** indicate as follows:

- 0 The related relay contact is open (relay de-energized)
- 1 The related relay contact is closed (relay energized)

16.04 Analog input 4 level

16.05 Analog input 5 level

⇅	±100.0	⇒		%	RO	Bi			P
---	--------	---	--	---	----	----	--	--	---

16.04 and **16.05** indicate the level of the signal applied to the related input terminal (51 or 52) as a percentage of the operating range.

The operating range is affected by the conversion rate of the analog-digital converter, due to varying tolerances.

16.07 Digital input/output F7 state indicator

16.08 Digital input/output F8 state indicator

16.09 Digital input/output F9 state indicator

⇅	0 ~ 1	⇒			RO	Bit			P
---	-------	---	--	--	----	-----	--	--	---

16.07 to **16.09** indicate as follows:

When operating an input...

- 0 The related input is inactive
- 1 The related input is active

When operating as an output...

- 0 The related output sources current from +24V nominal (inactive)
- 1 The related output sinks current to 0V (active)

16.10	Digital input F10 state indicator
16.11	Digital input F11 state indicator
16.12	Digital input F12 state indicator

↕	0 ~ 1	⇒			RO	Bit			P
---	-------	---	--	--	----	-----	--	--	---

16.10 to 16.12 indicate as follows:

- 0 The related input is inactive
- 1 The related input is active

16.13	Analog input 4 scaling
16.16	Analog input 5 scaling

↕	0 ~ 4.000	⇒	1		RW	Uni			
---	-----------	---	---	--	----	-----	--	--	--

Set for the required scaling of the related analog input signal. The default value causes the value of the destination parameter to be the same as the value of the related analog input level parameter (16.04 or 16.05).

16.14	Analog input 4 invert
16.17	Analog input 5 invert

↕	0 ~ 1	⇒	0		RW	Bit			
---	-------	---	---	--	----	-----	--	--	--

Set at 1 in order to invert the polarity of the related analog input signal. Negative input signals will then produce positive values in the destination parameter, and *vice versa*.

16.15	Analog input 4 destination parameter
16.18	Analog input 5 destination parameter

↕	0 ~ 20.50	⇒	0.0	menu. parameter	RW	Uni		R	P
---	-----------	---	-----	--------------------	----	-----	--	---	---

Enter the **menu.parameter** number of the required destination parameter. Only a variable parameter that is not protected (no **P** shown in the parameter description) can be used, otherwise no parameter is assigned to the input.

16.19 Analog output 3 source parameter

⇅	0 ~ 20.50	⇄	0.0	menu. parameter	RW	Uni		R	P
---	-----------	---	-----	--------------------	----	-----	--	---	---

Enter the **menu.parameter** number of the required source parameter. Only a variable parameter can be used, otherwise no parameter is assigned to the output.

16.20 Analog output 3 scaling

⇅	0 ~ 4.000	⇄	1		RW	Uni			
---	-----------	---	---	--	----	-----	--	--	--

Set for the required scaling of the analog output signal. The default value causes a 100% parameter value to produce a 10V output signal.

16.21 Digital input/output F7 destination or source parameter

16.24 Digital input/output F8 destination or source parameter

16.27 Digital input/output F9 destination or source parameter

⇅	0 ~ 20.50	⇄	0.0	menu. parameter	RW	Uni		R	P
---	-----------	---	-----	--------------------	----	-----	--	---	---

When operating as digital inputs

Enter the **menu.parameter** number of the required destination parameter. Only a bit parameter that is not protected (no **P** shown in the parameter description) can be used, otherwise no parameter is assigned to the input.

When operating as digital outputs

Enter the **menu.parameter** number of the source parameter. Only a bit parameter can be used, otherwise no parameter is assigned to the output.

16.22	Digital input/output F7 invert
16.25	Digital input/output F8 invert
16.28	Digital input/output F9 invert

⇅	0 ~ 1	⇄	0		RW	Bit			
---	-------	---	---	--	----	-----	--	--	--

When operating as digital inputs
Set at 1 to invert the logic state of the related applied signal. This will have the effect of inverting the active/inactive states at the input.

When operating as digital outputs
Set at 1 to invert the logic state obtained from the related source parameter. This will have the effect of inverting the source/sink states at the output.

16.23	Digital output F7 enable
16.26	Digital output F8 enable
16.29	Digital output F9 enable

⇅	0 ~ 1	⇄	0		RW	Bit		R	
---	-------	---	---	--	----	-----	--	---	--

Set at 1 to operate the related digital input/output as an output.

16.30	Digital input F10 destination parameter
16.32	Digital input F11 destination parameter
16.34	Digital input F12 destination parameter

⇅	0 ~ 20.50	⇄	0.0	menu. parameter	RW	Uni		R	P
---	-----------	---	-----	--------------------	----	-----	--	---	---

Enter the **menu.parameter** number of the required destination parameter. Only a bit parameter that is not protected (no **P** shown in the parameter description) can be used, otherwise no parameter is assigned to the input.

16.31	Digital input F10 invert
16.33	Digital input F11 invert
16.35	Digital input F12 invert

⇅	0 ~ 1	⇄	0		RW	Bit			
---	-------	---	---	--	----	-----	--	--	--

Set at 1 to invert the logic state of the related applied signal. This will have the effect of inverting the active/inactive states at the input.

16.36 Relay 2 source parameter**16.38 Relay 3 source parameter**

↕	0 ~ 20.50	⇄	0.0	menu. parameter	RW	Uni			P
---	-----------	---	-----	--------------------	----	-----	--	--	---

Enter the **menu.parameter** number of the required source parameter. Only a bit parameter can be used, otherwise no parameter is assigned to the output.

16.37 Relay 2 invert**16.39 Relay 3 invert**

↕	0 ~ 1	⇄	0		RW	Bit			
---	-------	---	---	--	----	-----	--	--	--

Set at 1 to invert the sense of the relay in relation to the logic state of the source parameter. By default, the relay contact is closed when the related source parameter is set at 1.

16.40 Positive-logic select

↕	0 ~ 1	⇄	0		RW	Bit		R	P
---	-------	---	---	--	----	-----	--	---	---

Set as follows for the digital inputs:

- 0 Negative logic (pull-down to make active)
- 1 Positive logic (pull-up to make active)

16.41 Open-collector outputs select

↕	0 ~ 1	⇄	0		RW	Bit		R	P
---	-------	---	---	--	----	-----	--	---	---

When digital inputs/outputs F7, F8, F9 are operating as outputs, by default they operate in push-pull to source or sink current depending on the logic state.

Set at **16.41** at 1 in order to configure these digital outputs as open-collector (current sink, pull-down only). This allows these outputs to be connected in a wired-OR configuration.

Setting **16.41** at 1 has no effect on digital inputs/outputs which are operating as inputs.

A Specifications

A.1 Relays 2, 3 (terminals 40, 41, 42)

Voltage rating	240VAC resistive load Installation category 1 (see Warning below)	120VAC resistive load Installation category 2
Maximum current	2A resistive	
Contact form	Normally open	



Warning

Category 1 installations must have suppression to limit supply-borne transients to a maximum of 1500V peak.

A.2 Digital inputs F10, F11, F12 (terminals 44, 45, 46)

Type	Single ended Complies with IEC1131 (positive-logic only)	
Logic sense	Programmable for positive or negative logic	
Maximum input voltage range	-15V to +33V	
Switching thresholds	10V to 13V (hysteresis: 0.5V)	
	Positive logic	Negative logic
Input current (at 15V)	+2mA to +3mA (current flow into the terminal) The input is <i>active</i>	-1.25mA to -2mA (current flow out of the terminal) The input is <i>inactive</i>
Input current (at 5V)	+0.5 mA to +1mA (current flow into the terminal) The input is <i>inactive</i>	< -2.5mA (current flow out of the terminal) The input is <i>active</i>
Overload protection	Series resistance	
Sampling interval	8 ms	

A.3 Digital inputs/outputs F7, F8, F9 (terminals 48, 49, 50)

When programmed as an input...		
Type	Single-ended Complies with IEC1131 (positive-logic only)	
Logic sense	Programmable for positive or negative logic	
Maximum input voltage range	-15V to +33V	
Switching thresholds	10V to 13V (hysteresis: 0.5V)	
	Positive logic	Negative logic
Input current (at 15V)	+2mA to +3mA (current flow into the terminal) The input is <i>active</i>	-1.25mA to -2mA (current flow out of the terminal) The input is <i>inactive</i>
Input current (at 5V)	+0.5 mA to +1mA (current flow into the terminal) The input is <i>inactive</i>	< -2.5mA (current flow out of the terminal) The input is <i>active</i>
Overload protection	Voltage clamp at -18V and +36V	
Sampling interval	8 ms	
When programmed as an output...		
Type	Push-pull (Can be programmed to operate as open-collector – upper push-pull stage made inactive)	
Output voltage when sourcing current	20.5V to 27V (at -30mA)	
Output voltage when sinking current	0V to 3V (at +30mA)	
Maximum permissible voltage that can be applied to the terminal	-15V to +33V	
Maximum total current	±30mA	
Overload protection	Current limited to ±30mA Voltage clamp at -18V and +36V	
Update interval	8 ms	

A.4 Analog inputs 4 & 5 (terminals 51, 52)

Type	Single-ended
Signal mode	Bipolar voltage
Input voltage operating range	± 9.996 V
Maximum input voltage range	-15V to +33V
Input impedance	20k Ω
Resolution	10 bits plus sign
Gain accuracy	$\pm 2\%$
Error in change of sign	± 5 mV max. relative to 0V
Sampling interval	8 msec

A.5 Analog output 3 (terminal 54)

Type	Single-ended
Signal mode	Bipolar voltage
Output voltage range	-10V to +10V
Maximum permissible voltage that can be applied to the terminal	-15V to +33V
Minimum output current	± 10 mA
Gain accuracy	$\pm 1.6\%$
Minimum load resistance	1k Ω
Maximum load capacitance	159nF
Overload protection	Short-circuit proof
Update interval	8 ms

