

User Guide

UD52

SIN-COS encoder
interface
small option module
for Unidrive

Part Number: 0460-0039

Issue Number: 2

General Information

The manufacturer accepts no liability for any consequences resulting from inappropriate, negligent or incorrect installation or adjustment of the operating parameters of the equipment or from mismatching the Drive with the motor.

This option module is intended for use only with Control Techniques Unidrive products. Any other use invalidates the warranty and may cause a safety hazard.

The contents of this Guide are believed to be correct at the time of printing. In the interests of a commitment to a policy of continuous development and improvement, the manufacturer reserves the right to change the specification of the product or its performance, or the contents of this Guide, without notice.

All rights reserved. No part of this Guide may be reproduced or transmitted in any form or by any means, electrical or mechanical including photocopying, recording or by any information storage or retrieval system, without permission in writing from the publisher.

Use within the European Union, etc

The following information applies where the end use of the Drive is within the European Union, the European Economic Area, or other regions which have implemented Directives of the European Council or equivalent measures.

The Drive, together with its associated option modules, complies with the Low Voltage Directive 73/23/EEC.

The installer is responsible for ensuring that the equipment into which the Drive is incorporated complies with all relevant Directives.

The complete equipment must comply with the EMC Directive 89/336/EEC.

If the Drive is incorporated into a machine, the manufacturer is responsible for ensuring that the machine complies with the Machinery Directive 89/392/EEC. In particular, the electrical equipment should generally comply with European Harmonised standard EN60204-1.

Copyright © July 1999 Control Techniques Drives Ltd

Author: RFD

Issue Code: 52nu2

Issue Date: July 1999

Contents

Chapter

1	Introduction	1
1.1	Main features of the UD52	1
1.2	Principle of operation	2
2	Safety Information	3
3	Installing the UD52	6
4	Making Connections	8
4.1	Locations of the terminals	8
4.2	Functions of the terminals	9
4.3	Serial communications	11
5	Setting Up the UD52	12
5.1	Initial setting up	12
5.2	Phase offset	12
5.3	Position information	13
5.4	Simulated-encoder outputs (terminals 50, 51, 53, 54)	15
5.5	Freeze inputs (terminals 48, 49)	16
5.6	Further setting up	16
6	Related Parameters	17
6.1	Introduction	17
6.2	Programmable software	17
6.3	Parameter descriptions	19
Appendix		
A	Specifications	A-1
A.1	Inputs and outputs	A-1
B	Advanced Functions	B-1
B.1	Alternative configurations	B-1
B.2	Aligning the encoder mechanically	B-2
C	Diagnostics	C-1
C.1	Trip codes	C-1

1 Introduction

1.1 Main features of the UD52

Note

The UD52 can be used only with Drives equipped with version 3 (or later) software. (Parameter 0.50 indicates the software version.)

- Applications** The UD52 SIN-COS encoder *small option module* is an interface module for installation in a Unidrive. The UD52 operates with encoders having 256, 512, 1024, 2048 or 4096 lines per revolution, and has a maximum operating frequency of 102.4kHz (3000RPM with a 2048-line encoder).
The UD52 can be used in a Drive operating in either the Closed-loop Vector or Closed-loop Servo mode in order to obtain speed feedback and very high resolution shaft position. The UD52 is fully compatible with the following *Stegmann* SIN-COS encoders:
SCS60, SCM60, SCS70, SCM70
These encoders are compatible with the two-wire serial communications port in the UD52.
- Absolute-position information** The UD52 can determine the absolute position within a revolution of a single-turn encoder, or in many revolutions of a multi-turn encoder. Unlike the case for a standard encoder, which must be rotated past its marker pulse in order to obtain absolute-position information, absolute-position information from a (suitable) SIN-COS encoder is obtained when the Drive is powered-up.
Speed and position information is displayed in parameters which can be read on the Drive display and/or via serial communications.
- Selection of encoder function** When a UD52 is fitted in the Drive, the Drive automatically uses the SIN-COS encoder as speed and position feedback for the motor. Alternatively, a standard quadrature encoder can be used for speed and position feedback, and the SIN-COS encoder used as an incremental reference.
- Simulated encoder outputs** The UD52 has simulated encoder outputs which normally use the SIN-COS encoder as the source, but can be reconfigured to use the main encoder (Encoder 1) connected to the 15-way D-type on the Drive as the source. These outputs produce *quadrature A/B* signals corresponding to the *line counts* from the source encoder. Also, these outputs can be configured for frequency and direction (**F/D**) signals.
- Installation** The UD52 must be fitted in the *small option module* bay of the Unidrive.
All connections to the Drive are made by a multi-way connector.
Connections from external equipment are made by a pluggable 16-way screw-terminal block on the UD52.

1.2 Principle of operation

The UD52 converts the sinusoidal output signals of a SIN-COS encoder into square waves and counts the edges (as in the case of a standard encoder) to yield position counts at a rate of four times the number of lines per revolution of the encoder. The constantly varying amplitudes of the sine waves are also measured by the UD52 in order to produce 2^{11} (2048) interpolated counts between encoder lines.

The overall resolution is the product of the number of interpolated counts and the number of encoder lines. For example, the UD52 used with a 512-line (2^9) encoder can give a resolution of 2^{20} (1 048 576) counts per revolution).

2 Safety Information

2.1 Warnings, Cautions and Notes

A **Warning** contains information which is essential for avoiding a safety hazard.

A **Caution** contains information which is necessary for avoiding a risk of damage to the product or other equipment.

A **Note** contains information which helps to ensure correct operation of the product.

2.2 Electrical safety – general warning

The voltages used in the Drive can cause severe electric shock and/or burns, and could be lethal. Extreme care is necessary at all times when working with or adjacent to the Drive.

Specific warnings are given at the relevant places in this User Guide.

The installation must comply with all relevant safety legislation in the country of use.

The Drive contains capacitors that remain charged to a potentially lethal voltage after the AC supply has been disconnected. If the Drive has been energized, the AC supply must be isolated at least ten minutes before work may continue.

2.3 System design

The Drive is intended as a component for professional incorporation into complete equipment or systems. If installed incorrectly the Drive may present a safety hazard. The Drive uses high voltages and currents, carries a high level of stored electrical energy, and is used to control mechanical equipment which can cause injury.

Close attention is required to the electrical installation and the system-design to avoid hazards either in normal operation or in the event of equipment malfunction. System-design, installation, commissioning and maintenance must be carried out by personnel who have the necessary training and experience. They must read this safety information and this User Guide carefully.

To ensure mechanical safety, additional safety devices such as electro-mechanical interlocks may be required. The Drive must not be used in a safety-critical application without additional high-integrity protection against hazards arising from a malfunction.

2.4 Environmental limits

Instructions in this User Guide regarding transport, storage, installation and use of Drives must be complied with, including the specified environmental limits. Drives must not be subjected to excessive physical force.

2.5 Compliance with regulations

The installer is responsible for complying with all relevant regulations, such as national wiring regulations, accident prevention regulations and electromagnetic compatibility (EMC) regulations. Particular attention must be given to the cross-sectional areas of conductors, the selection of fuses or other protection, and protective earth (ground) connections.

The *Unidrive Installation Guide* contains instructions for achieving compliance with specific EMC standards.

Within the European Union, all machinery in which this product is used must comply with the following directives:

89/392/EEC: Safety of Machinery

89/336/EEC: Electromagnetic Compatibility

2.6 Safety of personnel

The STOP function of the Drive does not remove dangerous voltages from the output of the Drive or from any external option unit.

The Stop and Start controls or electrical inputs of the Drive must not be relied upon to ensure safety of personnel. If a safety hazard could exist from unexpected starting of the Drive, an interlock that electrically isolates the Drive from the AC supply must be installed to prevent the motor being inadvertently started.

Careful consideration must be given to the functions of the Drive which might result in a hazard, either through their intended functions (eg. Auto-start) or through incorrect operation due to a fault or trip (eg. stop/start, forward/reverse, maximum speed).

Under certain conditions, the Drive can suddenly discontinue control of the motor. If the load on the motor could cause the motor speed to be increased (eg. hoists and cranes), a separate method of braking and stopping the motor must be used (eg. a mechanical brake).

Before connecting the AC supply to the Drive, it is important that you understand the operating controls and their operation. If in doubt, do not apply AC power to the Drive. Damage may occur, or lives put at risk. Carefully follow the instructions in this User Guide.

Before making adjustments to the Drive, ensure all personnel in the area are warned. Make notes of all adjustments that are made.

2.7 Risk analysis

In any application where a malfunction of the Drive could lead to damage, loss of life or injury, a risk analysis must be carried out, and where necessary, further measures taken to reduce the risk. This would normally be an appropriate form of independent safety back-up system using simple electro-mechanical components.

2.8 Signal connections

The control circuits are isolated from the power circuits in the Drive by basic insulation only, as specified in IEC664–1. The installer must ensure that the external control circuits are insulated from human contact by at least one layer of insulation rated for use at the AC supply voltage.

If the control circuits are to be connected to other circuits classified as Safety Extra Low Voltage (SELV) (eg. to a personal computer), an additional isolating barrier must be included in order to maintain the SELV classification.

2.9 Adjusting parameters

Some parameters have a profound effect on the operation of the Drive. They must not be altered without careful consideration of the impact on the controlled system. Measures must be taken to prevent unwanted changes due to error or tampering.

3 Installing the UD52



Warning

Before using the following procedure, refer to the Warnings at the beginning of Chapter 2 *Installing the Drive in the Unidrive Installation Guide*.

- 1 Ensure the Drive is operating in either the Closed-loop Vector or the Closed-loop Servo mode (this is indicated by parameter **11.31 (0.48)**).
- 2 Before installing the UD52 in the Unidrive, ensure the AC supply has been disconnected from the Drive for at least 10 minutes.
- 3 Check that the exterior of the UD52 is not damaged, and that the multi-way connector is free from dirt and debris. Do not install a damaged or dirty UD52 in the Drive.
- 4 Remove the terminal cover from the Drive (for removal instructions, see *Installing the Drive* in Chapter 2 of the Unidrive Installation Guide).
- 5 Position the multi-way connector on the rear of the UD52 over the connector in the Drive (see Figure 1), and press on the thumb pad to push the UD52 into place.
- 6 Re-fit the terminal cover to the Drive.
- 7 Connect the AC supply to the Drive.
- 8 Set parameter **.00** at **149** to unlock security.
- 9 Check that Menu-16 parameters are now available.
- 10 Check that parameter **16.01** is set at **4**.
- 11 If the checks in steps 8 and 9 fail, perform the following:
 - Remove the AC supply from the Drive.
 - Wait at least 10 minutes.
 - Remove the terminal cover.
 - Check that the UD52 is fully inserted.
 - Replace the terminal cover.
 - Re-apply the AC supply.
 - Check again that parameter **16.01** is set at **4**.

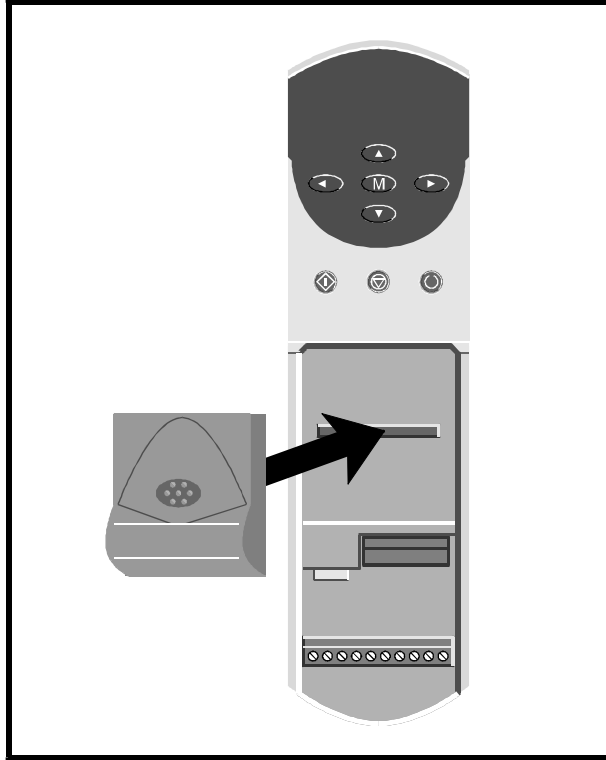

Figure 1 *Installing the UD52 in the Unidrive*

4 Making Connections



Warning

The control circuits are isolated from the power circuits in the Drive by basic insulation only, as specified in IEC664-1. The installer must ensure that the external control circuits are insulated from human contact by at least one layer of insulation rated for use at the AC supply voltage.

If the control circuits are to be connected to other circuits classified as Safety Extra Low Voltage (SELV) (eg. to a personal computer), an additional isolating barrier must be included in order to maintain the SELV classification.

4.1 Locations of the terminals

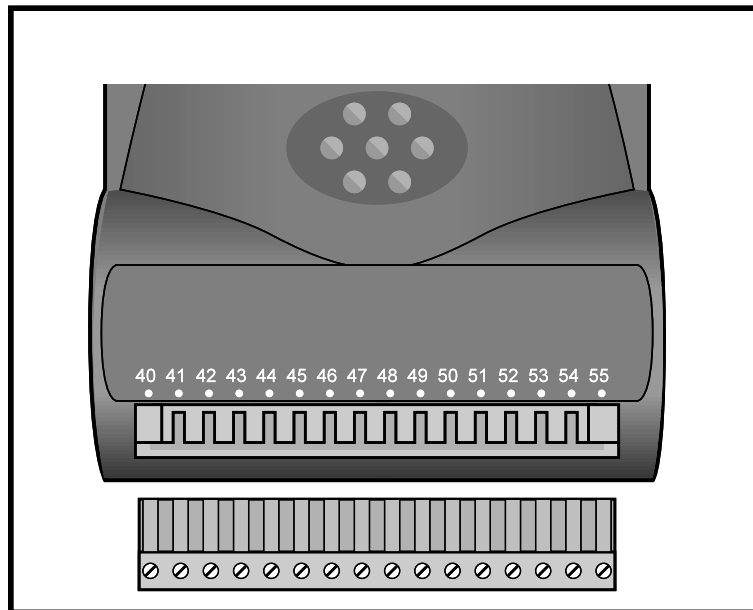

Figure 2 Location of the two-part terminal block

4.2 Functions of the terminals

(Note that \ indicates *not* (eg. **F** indicates **not F**)

Terminal	Name	Function	Comments
40	SININ	Sine input signal	Always required
41	SINREF	Sine input reference	
42	COSIN	Cosine input signal	
43	COSREF	Cosine input reference	
44	0V	0V common	
45	+VENC	DC supply to encoder	
46	SC DATA	Serial comms. EIA485 input and output	Use for Closed-loop Servo mode or when absolute position is required
47	SC DATA\	Serial comms. EIA485 input and output	
48	FREEZE	Freeze SC DATA input	Optional
49	FREEZE\	Freeze SC DATA\ input	
50	A (F)	Simulated-encoder phase quadrature output A or frequency output F (EIA485 serial link)	Optional
51	A\ (F\)	Simulated-encoder phase quadrature output A\ or frequency output F\ (EIA485 serial link)	
52	0V	0V common	
53	B (D)	Simulated-encoder phase quadrature output B or direction output D (EIA485 serial link)	
54	B\ (D\)	Simulated-encoder phase quadrature output B\ or direction output D\ (EIA485 serial link)	
55	0V	0V common	

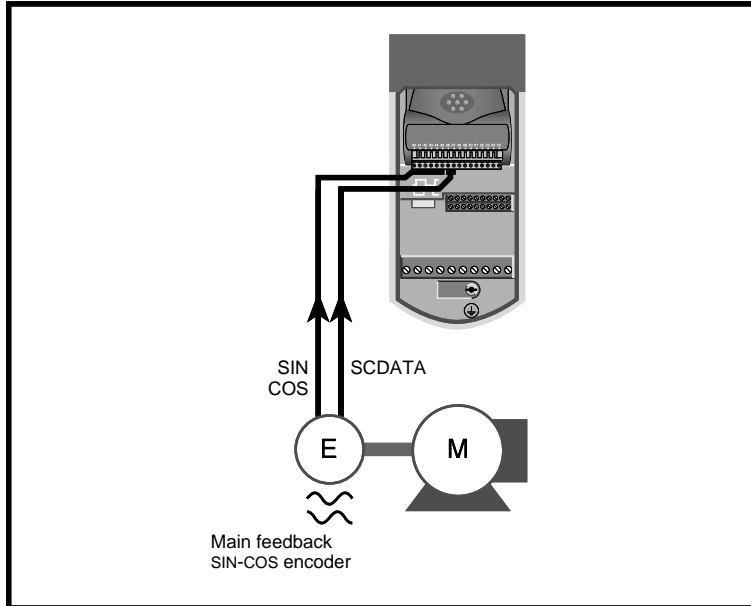

Figure 3 Standard wiring configuration

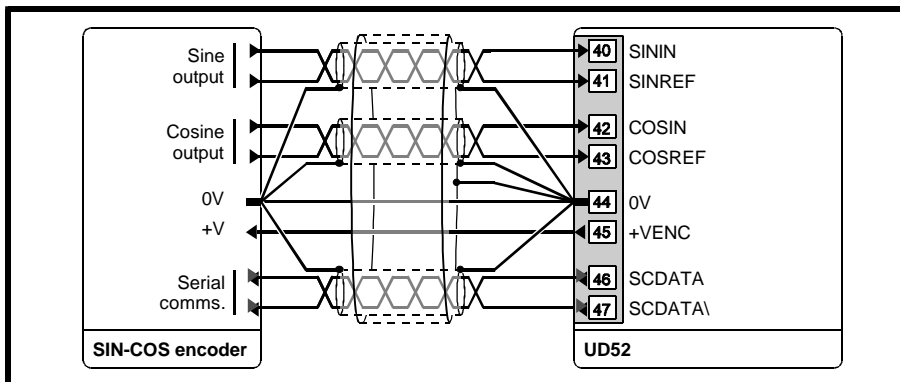

Figure 4 Grounding and screening recommendations for the UD52

The sinusoidal signals from a SIN-COS encoder are low-voltage analog signals. Ensure that electrical noise from the Drive or motor does not adversely affect the encoder feedback. Ensure that motor cables are shielded (see Chapter 2 *Installing the Drive* in the *Installation Guide*). Refer to Figure 3 for grounding and screening recommendations for the UD52.

For the simulated encoder connections, refer to the instructions for the equipment that is to receive the signals.

4.3 Serial communications

When absolute positioning is required, connect terminals 46, 47 *Serial communications* to the appropriate connections on the encoder.

The serial link allows the Drive (at power-up) to interrogate the SIN-COS encoder in order to determine the initial absolute position of the encoder shaft. When the interrogation is completed, the serial link is disabled.

If the serial link fails, the Drive will trip, showing trip code **SEP EC**.

When a SIN-COS encoder is used with a Drive operating in the Closed-loop Servo mode, absolute-position and phase-offset information is always required. In the Closed-loop Vector mode for controlling an induction motor, absolute-position and phase-offset information are optional.

When this information is not required, serial communications connections to the encoder do not need to be made. In this case, set parameter **16.16** *SIN-COS encoder – serial comms disable* at 1 (otherwise a **SEP EC** trip will occur at power-up).

Operating mode	Terminals 46, 47	Parameter 16.16
Closed-loop Servo mode Closed-loop Vector mode when absolute-position information is required	Connect to serial comms. port of SIN-COS encoder	0
Closed-loop Vector mode when absolute-position information is not required	No connections	1

5 Setting Up the UD52

The instructions in this chapter apply when the Drive is being set up for the first time with a UD52 fitted.

5.1 Initial setting up

The default supply voltage to the encoder from terminal 45 is +5.15V. If the encoder requires 8V, set parameter **16.15** *SIN-COS encoder – voltage select* at 1.

Enter the number of lines per revolution for the SIN-COS encoder in parameter **16.12** *SIN-COS encoder – No. of lines per revolution*. The value can be only a power of 2.

5.2 Phase offset

When the Drive is operating in the Closed-loop Servo mode, the phase offset of the SIN-COS encoder in relation to the motor shaft must be entered in parameter **16.09** *SIN-COS encoder – phase offset*.

The phase offset can be entered in either of the following ways:

- Performing an encoder phasing test. The UD52 measures the phase error automatically and enters the value in **16.09**.
- If the phase offset is known, you can enter the value manually in parameter **16.09**.

See also *Aligning the encoder mechanically* in Appendix B *Advanced functions*.

Encoder phasing test (Closed-loop Servo mode)



Warning

During the phasing test, the motor shaft rotates slowly. Before starting, make sure it will be safe for the motor to be run.

During the phasing test, the motor shaft rotates in two stages, as follows:

- Initial jump in position by $\frac{1}{N}$ revolution
- Subsequent rotation by $\frac{4}{N}$ revolution

Where N is the number of motor poles.

Examples

No. of poles	Initial jump	Subsequent rotation
2	$\frac{1}{2}$ revolution	2 revolutions
6	$\frac{1}{6}$ revolution	$\frac{2}{3}$ revolution

Procedure

- 1 Ensure the motor is unloaded (any load will create errors in the phase-offset measurement).
- 2 Set parameter **16.10** *SIN-COS encoder phasing test* at 1.
- 3 Enable the Drive.

The motor shaft rotates (as described above) and the measured value of phase offset is automatically entered in parameter **16.09** *SIN-COS encoder – phase offset*.

If a phasing test is attempted with a motor that has any of the following...

- High inertia
- No damping
- Small load on the shaft

...an incorrect value for the phase offset will be measured. Refer to parameter **5.27** in the *Unidrive Advanced User Guide*.

Note

If the Drive trips and the display indicates trip code ENC.PH7, this indicates either of the following:

The SIN and COS input connections from the encoder are incorrectly made

The phase sequence of the motor is reversed

After correcting the connections, repeat the procedure.

Magnetizing current test (Closed-loop Vector)

Refer to *Autotune* in Chapter 3 *Setting Up the Drive* in the *Unidrive User Guide*, or to parameter **5.12** in the *Unidrive Advanced User Guide*. If the Drive trips while Autotune is being performed see the Note above.

5.3 Position information

Counting revolutions

Single-turn encoder

Revolutions are not counted.

Multiple-turns encoder

Revolutions are indicated in parameter **16.03** *SIN-COS encoder – revolution count*. When the serial communications link to the encoder is used, at power-up the value stored in the encoder is transferred to **16.03**. When the value of **16.03** reaches a maximum limit that is defined in parameter **16.13** *SIN-COS encoder – No. of revolutions*, **16.03** is reset and the count starts again from zero.

By default, **16.03** will not count. When a multi-turn encoder is used, enter the required value in **16.13**, as follows:

16.13	16.03 counts up to...	16.13	16.03 counts up to...
0	0	8	255
1	1	9	511
2	3	10	1023
3	7	11	2047
4	15	12	4095
5	31	13	8191
6	63	14	16383
7	127	15	32767

Absolute-position parameters

When the following conditions are met...

- A compatible SIN-COS encoder is used and serial communications connections are made
- **16.16** *SIN-COS encoder – serial comms. disable* is set at 0 (default)
- **16.14** *SIN-COS as reference encoder* is set at 0 (default)

...the absolute position is indicated by the following parameters:

- 16.04** *SIN-COS encoder incremental position (coarse)*
- 16.05** *SIN-COS encoder incremental position (fine)*

Using position information for orientation

The position value in parameter **16.04** *SIN-COS encoder incremental position (coarse)* (at 16384 counts per revolution) is used as an input to the position-control algorithms in Menu 13. This allows orientation to be performed within one revolution.

Using position information for digital lock

The digital-lock algorithm uses only incremental changes in position obtained from parameter **16.04** and ignores the multi-turn information in parameter **16.03** *SIN-COS encoder – revolution count*.

Only incremental digital lock is performed; multi-turn absolute orientation is not supported.

5.4 Simulated-encoder outputs (terminals 50, 51, 53, 54)

The simulated-encoder outputs can be connected to external equipment for monitoring the output of either a SIN-COS encoder connected to the UD52 or the main encoder (Encoder 1) that is connected to the 15-way D-type on the Drive. By default, the SIN-COS encoder is used as the source. To select Encoder 1, set parameter **16.06** *Simulated-encoder output select* at 1.

Quadrature AB, or frequency and direction

By default, the simulated-encoder outputs are phase-quadrature **A** and **B** signals. For frequency (**F**) and direction (**D**) signals, set parameter **16.08** *Simulated encoder – F/D output enable* at 1.

Pulses per revolution

The simulated-encoder outputs are derived from the polarity changes in the SIN-COS encoder outputs, giving a resolution of four times the number of encoder lines per revolution.

The number of pulses per revolution (PPR) is dependent on the number of lines per revolution of the SIN-COS encoder as well as on the value **16.07** *Simulated-encoder output scaling*.

By default, the outputs are scaled 1:1. To change the scaling, enter the required value in parameter **16.07** *Simulated-encoder output scaling*. The scaling factor is given by the following:

$$\frac{1}{2^{[16.07]}}$$

5.5 Freeze inputs (terminals 48, 49)

If the *Freeze* function is required, a UD70 *large option module* must be fitted in the Drive in order to read the *freeze* position, and pass the data to the system controller or PLC. The initiating signal for the *freeze* function must be applied to terminals 48 and 49 on the UD52.

Related UD70 parameters

_Q20%.5	Control word (bit 5)
----------------	-----------------------------

Set at 1 for the current absolute positions of the feedback and reference encoders to be entered in **_Q21%** and **_Q22%** when the *Freeze* input is activated.

_Q20%.5 is reset to zero when the values have been entered.

_Q21%	Feedback-encoder freeze value
Units	Encoder lines
Range	-2^{31} to 2^{31}
Reset	H = S/V S = N/A P = N/A

_Q22%	Reference-encoder freeze value
Units	Encoder lines
Range	-2^{31} to 2^{31}
Reset	H = S/V S = N/A P = N/A

5.6 Further setting up

Refer to *Parameters descriptions* in Chapter 6 *Related Parameters* for setting up the following:

Function	Parameter
Disable interpolation	16.17
Disable updating the position parameters when reading	16.11

6 Related Parameters

6.1 Introduction

The parameters listed in this chapter are used for programming and monitoring the UD52. Refer to the *Unidrive User Guide* for programming instructions.



Before attempting to adjust any parameters, refer to the Warnings and Notes at the beginning of Chapter 3 *Setting up the Drive* in the Unidrive User Guide.

6.2 Programmable software

Key

Type of parameter



RO Read-only



RW Read-write

...select

Select from two settings

...enable

Make or allow a function to operate

...disable

Stop or disallow a function from operating

...indicator

The value can only be read

Limitations of use

S The new parameter-value is saved when the AC supply is disconnected from the Drive.

P Protected parameter; the parameter cannot be used as the destination parameter for a programmable input.

Range

Bi Variable parameter having bipolar value range.

Uni Variable parameter having unipolar value range.

Bit Bit parameter

Symbols

⇔ Default value

⌈⌋ Range of values

~ Indicates a range of values
(in the case of bit parameters, ~ indicates *or*).

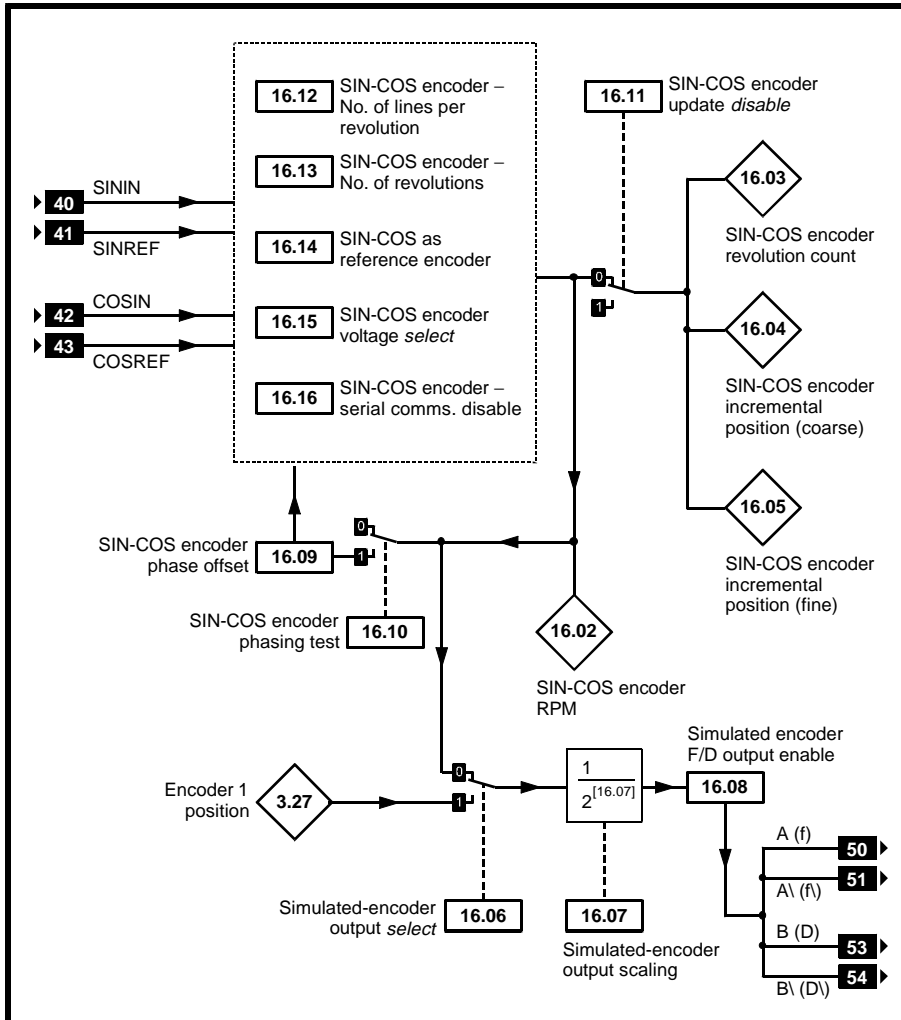

Figure 5 Logic diagram for the UD52

6.3 Parameter descriptions

16.01 Option module fitted code

⇅	0 ~ 100	⇒			RO	Uni			P
---	---------	---	--	--	----	-----	--	--	---

16.01 indicates the type of small option module that is fitted in the Drive, as follows:

- 0 No small option module
- 1 UD50 Additional I/O
- 2 UD51 Second encoder interface
- 3 UD53 Resolver interface
- 4 UD52 SIN-COS encoder interface

16.02 SIN-cos encoder RPM

⇅	±30 000	⇒		RPM	RO	Bi			P
---	---------	---	--	-----	----	----	--	--	---

16.02 indicates the speed of rotation of the encoder. This depends on the correct value having been entered in **16.12** *SIN-COS encoder – No. of lines per revolution*.

16.03 SIN-cos encoder – revolution count

⇅	0 ~ 32767	⇒		Revolutions	RO	Uni			P
---	-----------	---	--	-------------	----	-----	--	--	---

When a multiple-turns encoder and an appropriate value has been entered in **16.13** *SIN-COS encoder – No. of revolutions*, **16.03** indicates the absolute position. In other cases, **16.03** indicates relative position.

When the Drive is powered-up and the serial communications link is used, the value of **16.03** is set at the value stored in the encoder. The value increases to a maximum value determined by the setting of parameter **16.13** *SIN-COS encoder – No. of revolutions*. On the following revolution, the value of **16.03** returns to zero ready to count up again.

16.04 SIN-cos encoder – incremental position (coarse)

⇅	0 ~ 16383	⇒		rev/16384	RO	Uni			P
---	-----------	---	--	-----------	----	-----	--	--	---

16.04 indicates the absolute position of the motor shaft. This position information is derived by the UD52 counting the changes in sign of the encoder outputs, some of the interpolated information and the initial position information.

See **16.05** *SIN-COS encoder – incremental position (fine)*.

16.05 SIN-cos encoder – incremental position (fine)

⇅	0 ~ 255	⇌		rev/4194304	RO	Uni			P
---	---------	---	--	-------------	----	-----	--	--	---

16.04 and 16.05 indicate the position of the motor shaft to a resolution given by:

$$\frac{(256 \times [16.04]) + [16.05]}{4194304} \text{revolution}$$

When the number of encoder lines is less than 2048 (see 16.12), 16.05 indicates the following increments:

No. of lines	16.05 increment	Available resolution
256	8	524288
512	4	1048576
1024	2	2097152
2048	1	4194304
4098	1	4194304 The least significant digit is not available

16.06 Simulated-encoder output select

⇅	0 ~ 1	⇌	0		RW	Bit			
---	-------	---	---	--	----	-----	--	--	--

The simulated encoder outputs appear on the following terminals:

Terminal	Name
50	A (F)
51	A \ (F\)
53	B (D)
54	B \ (D\)

Set 16.06 to select the source of the simulated encoder outputs as follows:

16.06	Source
0	SIN-COS encoder
1	Encoder 1

The simulated encoder outputs are derived only from the counted sign reversals of the source encoder and do not include interpolation. No zero-pulse information is produced.

16.07 Simulated-encoder output scaling

0 ~ 15	⇌	0	2 ⁿ	RW	Uni			
--------	---	---	----------------	----	-----	--	--	--

Enter the required value in **16.07** for scaling the simulated-encoder output. The scaling factor is as follows:

$$\frac{1}{2^{[16.07]}}$$

16.08 Simulated encoder- F/D output enable

0 ~ 1	⇌	0		RW	Bit			
-------	---	---	--	----	-----	--	--	--

Use **16.08** to select the output mode of terminals 50, 51, 53, 54, as follows:

16.08	Output mode
0	A/B quadrature signals
1	Frequency and direction signals

16.09 SIN-cos encoder- phase offset

0 ~ 6143	⇌		1/6143 rev.	RW	Uni	S		P
----------	---	--	-------------	----	-----	---	--	---

16.09 indicates the value of phase offset. See *Phase offset* in Chapter 5 *Setting up the UD52* for ways in which the value is entered.

The value is saved at power-down and is changed only when one of the procedures in *Phase offset* is performed.

When the operating mode of the Drive is changed, **16.09** is reset to zero.

Restoring default values does not affect the value of **16.09**.

16.10 SIN-cos encoder phasing test

0 ~ 1	⇌	0		RW	Bit			
-------	---	---	--	----	-----	--	--	--

Set **16.10** at 1 to initiate the encoder phasing test (on completion, **16.10** automatically returns to 0). See *Phase offset* in Chapter 5 *Setting up the UD52*.

16.11 SIN-cos encoder update *disable*

↕	0 ~ 1	⇄	0		RW	Bit			
---	-------	---	---	--	----	-----	--	--	--

When **16.11** is set at 0 (default), and the SIN-COS encoder shaft position is being read from parameters **16.03**, **16.04** and **16.05** by a large option module (eg. UD70) or via serial communications, the values of these parameters are free to change during the read process. This can result in large position-errors being read.

To ensure that the position information from all three parameters is consistent when reading the values, set **16.11** at 1 to hold the three parameters at the last complete set of values. When the read process is completed, return **16.11** at 0 to allow the parameter values to continue to be updated.

16.12 SIN-cos encoder – No. of lines per revolution

↕	256 ~ 4096	⇄	512	lines	RW	Uni			
---	------------	---	-----	-------	----	-----	--	--	--

Enter the number of lines per revolution of the SIN-COS encoder being used. The value can only be a power of 2.

16.13 SIN-cos encoder – No. of revolutions

↕	0 ~ 15	⇄	0		RW	Uni			
---	--------	---	---	--	----	-----	--	--	--

Enter the required value to give the number of revolutions that parameter **16.03** *SIN-COS encoder – revolution count* is to count to before being reset. The entered value must be the required power of 2, as follows:

16.13	16.03 counts up to...	16.13	16.03 counts up to...
0	0	8	255
1	1	9	511
2	3	10	1023
3	7	11	2047
4	15	12	4095
5	31	13	8191
6	63	14	16383
7	127	15	32767

For use with a single-turn encoder, set **16.13** at 0.

16.14 SIN-cos as reference encoder

↕	0~1	⇌	0		RW	Bit			
---	-----	---	---	--	----	-----	--	--	--

To use the SIN-COS encoder for speed and position reference, set **16.14** at 1. See *Alternative configurations* in Appendix B *Advanced functions*.

16.15 SIN-cos encoder- voltage select

↕	0~1	⇌	0		RW	Bit			
---	-----	---	---	--	----	-----	--	--	--



Caution

A 5V encoder can be damaged if it is supplied with 8V

Use **16.15** to select the encoder DC supply voltage from terminal 45, as follows:

16.15	Voltage
0	+5.15V
1	+8.0V

16.16 SIN-cos encoder- serial comms. *disable*

↕	0~1	⇌	0		RW	Bit			
---	-----	---	---	--	----	-----	--	--	--

When the initial-position information is not required (or not available) from the encoder, set **16.16** at 1 to disable the serial communications link. (See *Serial communications* in Chapter 5 *Setting Up*)

16.17 SIN-cos encoder- interpolation *disable*

↕	0~1	⇌	0		RW	Bit			
---	-----	---	---	--	----	-----	--	--	--

Set **16.17** at 1 when the position information is to consist only of the basic line count (without interpolation being obtained from the intermediate values of the sine wave outputs of the encoder).

A Specifications

A.1 Inputs and outputs

Inputs SININ, SINREF, COSIN, COSREF (terminals 40, 41, 42, 43)

Type	Differential voltage
Signal level	1.1V peak-to-peak
Maximum input frequency	105kHz (not all SIN-COS encoders are designed to operate at this maximum frequency)
Absolute maximum DC voltage that can be applied	$\pm 4V$
Input resistance	$1k\Omega \pm 5\%$ (to 0V)

Encoder DC supply (VENC) (terminal 45)

Nominal voltage	+5.15V or +8V
Tolerance	$\pm 3\%$
Maximum output current	300mA
Protection	Protected against short-circuit and overload

Serial communications (terminals 46, 47)

Transceiver mode	EIA485 2-wire master-slave
Bias resistors	$1k\Omega$ (If the inputs are not connected, the bias resistors will ensure logic 1 is detected)
Termination resistor	$120\Omega \pm 5\%$ (internal, no series capacitor)
Mode of operation	Differential
Maximum permissible number of drivers on the serial link	32
Maximum cable length	1200m (4000 ft)
Maximum data rate (20kbps)	10Mbaud
Maximum-common mode voltage	$-7V \sim +12V$
Driver output signal	$\pm 1.5V$
Driver load	60Ω
Receiver input resistance	$>12k\Omega$
Receiver sensitivity	$\pm 300mV$ within the common-mode voltage range

Freeze inputs (terminals 48, 49)

EIA485 differential (see terminals 46, 47)

Simulated-encoder outputs (terminals 50, 51, 53, 54)

Output type	EIA 485
Maximum output frequency	Quadrature: 205kHz Frequency and direction: 410kHz
Output voltage	Conforms to EIA 485
Absolute maximum voltage that can be applied to each terminal	-10V ~ +15V
Protection	Current limit with thermal protection

Output state	Typical output voltage relative to 0V	
	5mA load	25mA load
Low	1.0V	1.5V
High	4.5V	4V

0V common (terminals 44, 52, 55)

Absolute maximum current that can be applied through each terminal	200mA
--	-------

B Advanced Functions

B.1 Alternative configurations

Reference: Quadrature encoder connected to the 15-way D-type in the Drive

Main feedback: SIN-COS encoder connected to the UD52

Refer to Menus 3, 13, 16

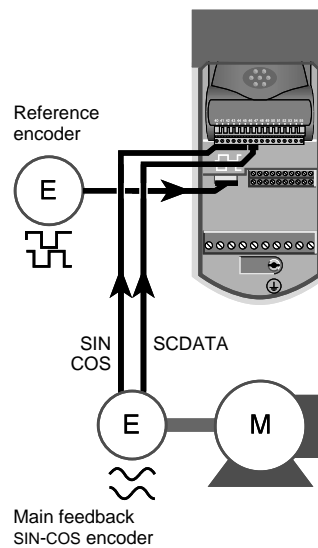

Reference: SIN-COS encoder connected to the UD52

Main feedback: Quadrature encoder connected to the 15-way D-type in the Drive

Refer to Menus 3, 13, 16

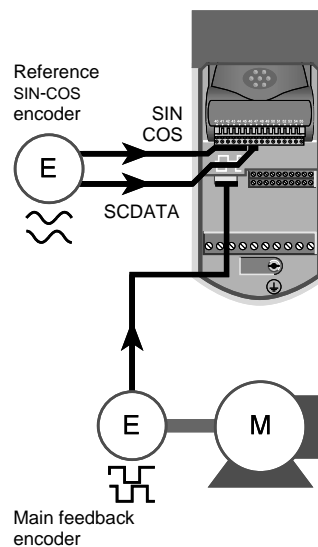

B.2 Aligning the encoder mechanically (Closed-loop Servo mode)

Note

Use this procedure only when the procedure described in *Phase offset in Chapter 5 Setting Up the UD52 cannot be performed.*

When the SIN-COS encoder is used as the feedback, use the following procedure to precisely align the encoder with the motor (for zero phase-offset). Precise alignment can be achieved only when the encoder is connected to the Drive.

The Drive detects the exact points of polarity reversal of the (sine wave) outputs. It would not be possible to identify these accurately on an oscilloscope as in the case of standard encoders.



Warning

During this procedure, the motor shaft will be rotated suddenly to a new position. Before starting, make sure it will be safe for the motor shaft to be rotated.

- 1 Disconnect the motor from the Drive.
- 2 Ensure the shaft is unloaded and free to rotate.
- 3 Apply a *direct current* of 50% of the motor rated current through the motor windings, as shown in Figure B-1.

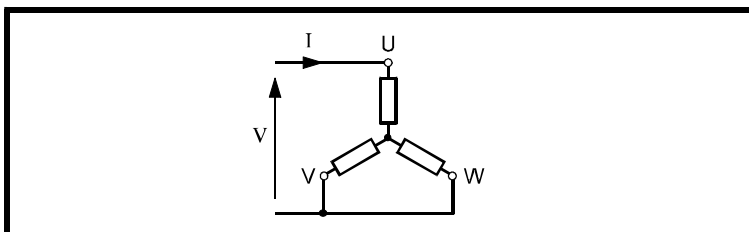

Figure B-1 Connecting a motor to a DC source for mechanically aligning the encoder shaft

The motor shaft will rotate to one of several positions depending on the number of pole-pairs. For example, the shaft of a 6-pole motor will stop at one of three places.

The encoder position is indicated by parameter **16.04** *SIN-COS encoder – incremental position (coarse)*. The value will be given by:

$$\frac{n}{[\text{No. polepairs}]} \times 16384$$

If the encoder is correctly aligned, the value of **n** will always be an integer (varying from 0 to [number of pole pairs – 1]). For a 6-pole motor, this value would be 0, 1 or 2 depending on the shaft position. The value of **16.04** will then be one of the following:

$$0 \quad \left[\frac{0}{3} \times 16384 \right]$$

$$5461 \quad \left[\frac{1}{3} \times 16384 \right]$$

$$10923 \quad \left[\frac{2}{3} \times 16384 \right]$$

If the encoder is not aligned with the motor windings, **16.04** will indicate other values (**n** will not be an integer). To align the encoder, continue to pass direct current through the motor windings and rotate the encoder relative to the motor until parameter **16.04** indicates one of the correct values.

When the SIN-COS encoder is used for feedback (Stand-alone and Slave configurations), ensure the value of parameter **16.09** *SIN-COS encoder – phase offset* is zero.

C Diagnostics

C.1 Trip codes

The following trip codes are associated with the UD52:

Drive display	No.	Conditions
SEP	9	Encoder DC supply short-circuit (terminals 44 and 45).
ENC.PH7	17	The SIN and COS connections from the encoder are incorrectly made or the phase sequence of the motor connections is reversed.
SEP EC	35	Failure of the serial communications link to the encoder. Absolute position information will then not be obtained. After rectifying the fault, remove then re-connect the AC supply to the Drive in order to obtain absolute position information. The trip could be due to any of the following: <ul style="list-style-type: none">Incorrect serial comms. connections (terminals 46 and 47)Encoder DC supply not connected (terminals 44 and 45)Encoder DC supply voltage incorrect (parameter 16.15)Encoder DC supply failed
SEP EF	36	Fault in the SIN-COS encoder.
SEP.diS	180	The type of small option module that the Drive has been programmed to operate with has been removed or is not fitted correctly. Perform either of the following: Ensure the appropriate type of small option module is correctly fitted To operate the Drive in the present configuration, set parameter 00 at 1000 and press the STOP/RESET key.

