



## *User Guide*

---

# ***SM-CANopen***

---

Unidrive SP  
Commander SK  
Commander SX

Part Number: 0471-0020-07  
Issue: 7

## **General Information**

The manufacturer accepts no liability for any consequences resulting from inappropriate, negligent or incorrect installation or adjustment of the optional operating parameters of the equipment or from mismatching the variable speed drive with the motor.

The contents of this guide are believed to be correct at the time of printing. In the interests of a commitment to a policy of continuous development and improvement, Control Techniques reserves the right to change the specification of the product or its performance or the contents of this guide without notice.

All rights reserved. No parts of this guide may be reproduced or transmitted in any form or by any means, electrical or mechanical including photocopying, recording or by an information storage or retrieval system, without permission in writing from the publisher.

---

# Contents

---

<b>1</b>	<b>Safety Information .....</b>	<b>6</b>
1.1	Warnings, cautions and notes .....	6
1.2	Electrical safety - general warning .....	6
1.3	System design and safety of personnel .....	6
1.4	Environmental limits .....	7
1.5	Compliance with regulations .....	7
1.6	Motor .....	7
1.7	Adjusting parameters .....	7
<b>2</b>	<b>Introduction .....</b>	<b>8</b>
2.1	What Is CANopen? .....	8
2.2	What is SM-CANopen? .....	10
2.3	General specification .....	10
2.4	Solutions Module identification .....	11
2.5	Product conformance certificate .....	11
2.6	Conventions used in this guide .....	12
2.7	Conventions used for SM-CANopen .....	12
<b>3</b>	<b>Mechanical Installation .....</b>	<b>13</b>
3.1	Installation .....	13
<b>4</b>	<b>Electrical Installation .....</b>	<b>18</b>
4.1	SM-CANopen terminal descriptions .....	18
4.2	SM-CANopen connections .....	19
4.3	CANopen cable .....	19
4.4	CANopen network termination .....	20
4.5	SM-CANopen cable shield connections .....	20
4.6	CANopen ground point .....	21
4.7	Using the drive as a ground point .....	21
4.8	Unidrive SP: SM-CANopen back-up power supply .....	23
4.9	Maximum network length .....	24
4.10	Spurs .....	24
4.11	Minimum node to node cable length .....	24

<b>5</b>	<b>Getting Started .....</b>	<b>25</b>
5.1	SM-CANopen node address .....	26
5.2	SM-CANopen data rate .....	26
5.3	Flexible PDO Numbering (software compatibility) .....	27
5.4	PDO number configuration .....	27
5.5	PDO structure (PDOs A,B,C & D) .....	28
5.6	Types of set-up .....	28
5.7	Configuration overview .....	29
5.8	Setup flowcharts .....	31
5.9	SM-CANopen data format .....	41
5.10	Default COB-IDs and transmission type .....	41
5.11	SM-CANopen operating status .....	42
5.12	Resetting the SM-CANopen (re-initialising) .....	43
5.13	Unidrive SP: reset Solutions Modules .....	43
5.14	Storing SM-CANopen configuration parameters .....	43
5.15	Restore SM-CANopen defaults .....	44
5.16	Restore previous SM-CANopen configuration .....	45
<b>6</b>	<b>EDS Files .....</b>	<b>47</b>
6.1	What are EDS files? .....	47
6.2	Supplied EDS files .....	47
6.3	Changing EDS files/customisation .....	48
<b>7</b>	<b>Cyclic Data .....</b>	<b>49</b>
7.1	What is a "Process Data Object"? .....	49
7.2	SM-CANopen data format .....	49
7.3	Data size on the network .....	50
7.4	Default settings .....	50
7.5	PDO data mapping errors .....	52
7.6	Unused PDO data channels .....	52
7.7	Changing PDO mapping parameters .....	52
7.8	Blank mapping parameters .....	53
<b>8</b>	<b>Non-Cyclic Data .....</b>	<b>54</b>
8.1	Service data object (SDO) parameter access .....	54
8.2	Mode 1 - CT Single Word mode .....	56
8.3	SM-CANopen set-up using non-cyclic data .....	65
<b>9</b>	<b>Control and Status Words .....</b>	<b>66</b>
9.1	What are control and status words? .....	66
9.2	Control word .....	66
9.3	Status word .....	68
<b>10</b>	<b>Diagnostics .....</b>	<b>70</b>
10.1	Module ID code .....	71
10.2	SM-CANopen firmware version .....	71
10.3	SM-CANopen node address .....	71
10.4	SM-CANopen data rate .....	72
10.5	SM-CANopen operating status .....	72
10.6	SM-CANopen mapping status .....	73
10.7	SM-CANopen error code .....	76
10.8	Stuff Bits .....	77

<b>11</b>	<b>Advanced Features .....</b>	<b>78</b>
11.1	SM-CANopen network loss trip time-out .....	78
11.2	SM-CANopen data endian format .....	79
11.3	Unidrive SP: inter-option communication timing .....	79
11.4	Local Solutions Module parameter access .....	80
11.5	Unidrive SP: mapping To SM-Applications parameters .....	80
11.6	Unidrive SP: block mapping .....	81
11.7	Direct data mapping .....	83
11.8	Cyclic data compression .....	84
11.9	Unidrive SP: event task trigger in SM-Applications .....	84
11.10	PDOA length .....	85
11.11	PDO counter .....	86
11.12	Unidrive SP: linking object dictionary entries to DPL program variables ..	86
11.13	Unidrive SP: SM-Applications object priority .....	88
11.14	Unidrive SP: synchronised data transfer mode .....	89
11.15	Unidrive SP: position control without interpolation .....	94
11.16	Unidrive SP: position control with interpolation .....	97
11.17	Synchronisation example .....	99
<b>12</b>	<b>CANopen Reference .....</b>	<b>106</b>
12.1	Communication profile objects supported .....	106
12.2	Basic data types .....	106
12.3	Device type .....	107
12.4	Flexible PDO numbering (0x2800 and 0x2801) .....	114
12.5	Mapping parameter values .....	114
12.6	RxPDO communication parameters .....	117
12.7	RxPDO mapping parameters .....	119
12.8	TxPDO communication parameters .....	121
12.9	TxPDO mapping parameters .....	124
12.10	Network management objects (NMT) .....	127
12.11	NMT commands .....	128
12.12	Layer setting services (LSS) .....	129
12.13	Emergency object .....	134
12.14	Emergency object state .....	135
12.15	Unidrive SP and Commander SK: device profiles .....	137
<b>13</b>	<b>Quick Reference .....</b>	<b>154</b>
13.1	Drive menu parameter reference .....	154
13.2	Virtual parameter reference .....	155
13.3	Object reference .....	156
<b>14</b>	<b>Glossary Of Terms .....</b>	<b>157</b>

---

# 1 Safety Information

---

## 1.1 Warnings, cautions and notes



A **Warning** contains information, which is essential for avoiding a safety hazard.



A **Caution** contains information, which is necessary for avoiding a risk of damage to the product or other equipment.

### NOTE

A **Note** contains information, which helps to ensure correct operation of the product.

## 1.2 Electrical safety - general warning

The voltages used in the drive can cause severe electrical shock and/or burns, and could be lethal. Extreme care is necessary at all times when working with or adjacent to the drive.

Specific warnings are given at the relevant places in this User Guide.

## 1.3 System design and safety of personnel

The drive is intended as a component for professional incorporation into complete equipment or a system. If installed incorrectly, the drive may present a safety hazard.

The drive uses high voltages and currents, carries a high level of stored electrical energy, and is used to control equipment which can cause injury.

Close attention is required to the electrical installation and the system design to avoid hazards either in normal operation or in the event of equipment malfunction. System design, installation, commissioning and maintenance must be carried out by personnel who have the necessary training and experience. They must read this safety information and this User Guide carefully.

The STOP and SECURE DISABLE functions of the drive do not isolate dangerous voltages from the output of the drive or from any external option unit. The supply must be disconnected by an approved electrical isolation device before gaining access to the electrical connections.

With the sole exception of the SECURE DISABLE function, none of the drive functions must be used to ensure safety of personnel, i.e. they must not be used for safety-related functions.

The SECURE DISABLE function is only available as standard on the Unidrive SP. The Commander SK does not have a secure disable feature. Secure disable is available on Commander SX as an option.

Careful consideration must be given to the functions of the drive which might result in a hazard, either through their intended behaviour or through incorrect operation due to a fault. In any application where a malfunction of the drive or its control system could lead to or allow damage, loss or injury, a risk analysis must be carried out, and where necessary, further measures taken to reduce the risk - for example, an over-speed

protection device in case of failure of the speed control, or a fail-safe mechanical brake in case of loss of motor braking.

The SECURE DISABLE function and secure input on Unidrive SP meet the requirements of EN954-1 category 3 for the prevention of unexpected starting of the drive. They may be used in a safety-related application. **The system designer is responsible for ensuring that the complete system is safe and designed correctly according to the relevant safety standards.**

## 1.4 Environmental limits

Instructions in the *Unidrive SP User Guide*, *Commander SK Getting Started Guide*, *Commander SK Technical Data Guide* and *Commander SX User Guide* regarding transport, storage, installation and use of the drive must be complied with, including the specified environmental limits. Drives must not be subjected to excessive physical force.

## 1.5 Compliance with regulations

The installer is responsible for complying with all relevant regulations, such as national wiring regulations, accident prevention regulations and electromagnetic compatibility (EMC) regulations. Particular attention must be given to the cross-sectional areas of conductors, the selection of fuses or other protection, and protective earth (ground) connections.

The *Unidrive SP User Guide*, *Commander SK EMC Guide* and *Commander SX User Guide* contain instructions for achieving compliance with specific EMC standards.

Within the European Union, all machinery in which this product is used must comply with the following directives:

98/37/EC: Safety of machinery.

89/336/EEC: Electromagnetic Compatibility.

## 1.6 Motor

Ensure the motor is installed in accordance with the manufacturer's recommendations. Ensure the motor shaft is not exposed.

Standard squirrel cage induction motors are designed for single speed operation. If it is intended to use the capability of the drive to run a motor at speeds above its designed maximum, it is strongly recommended that the manufacturer is consulted first.

Low speeds may cause the motor to overheat because the cooling fan becomes less effective. The motor should be fitted with a protection thermistor. If necessary, an electric forced vent fan should be used.

The values of the motor parameters set in the drive affect the protection of the motor. The default values in the drive should not be relied upon.

It is essential that the correct value is entered in the motor rated current parameter: Pr **0.46** for Unidrive SP and Pr **0.06** in Commander SK and Commander SX. This affects the thermal protection of the motor.

## 1.7 Adjusting parameters

Some parameters have a profound effect on the operation of the drive. They must not be altered without careful consideration of the impact on the controlled system.

Measures must be taken to prevent unwanted changes due to error or tampering.

## 2 Introduction

### 2.1 What Is CANopen?

CANopen is a networking system that falls into the generic category of fieldbus. Fieldbuses are generally defined as industrial networking systems that are intended to replace traditional wiring systems. Figure 2-1 shows the traditional cabling requirements to transfer signals between 2 slaves and a master.

Figure 2-1 Traditional cable layout

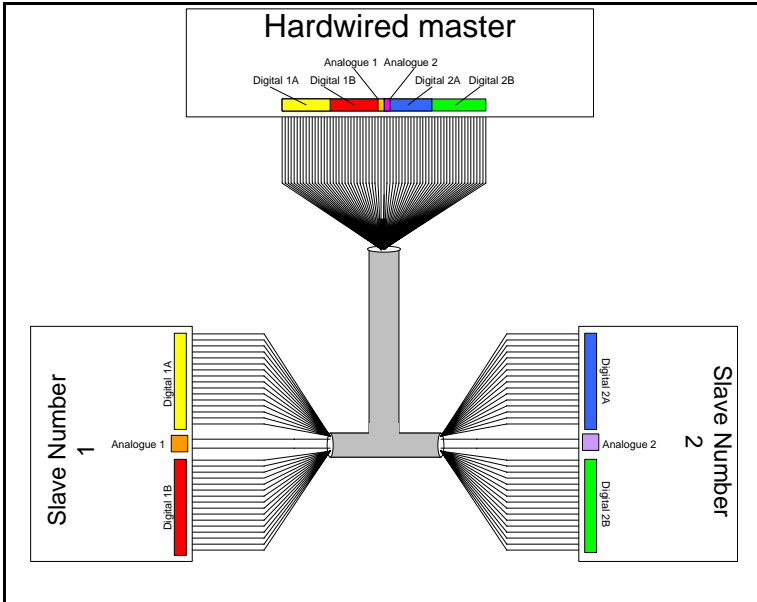

Table 2.1 details how the wiring is used to communicate data between the master and the slaves. Each signal that is communicated requires one signal wire giving a total of 66 signal wires plus a 0V return.

Table 2.1 Traditional wiring details

Number of signals	Type	Source / Destination	Description
16	digital Inputs	slave 1 to master	status signals
16	digital outputs	master to slave 1	control signals
1	analogue output	master to slave 1	control signal
16	digital inputs	slave 2 to master	status signals
16	digital outputs	master to slave 2	control signals
1	analogue output	master to slave 2	control signal

A fieldbus topology such as CANopen allows the same configuration to be realised using only 2 signal wires plus a screen. This method of communication saves significantly on the amount of cabling required and can improve overall system reliability as the number of interconnections is greatly reduced.

Figure 2-2 shows a typical CANopen network system transferring the same signals as given in the traditionally wired example. The signals are now transmitted by converting them into a serial data stream which is received by the master as if they were connected using traditional wiring. The data stream on CANopen allows up to 32 (16 input and 16 output) independent values to be sent or received by the master, there is also a method available to allow a single channel random access (non-cyclic data access) to drive parameters.

**Figure 2-2 CANopen cable layout**

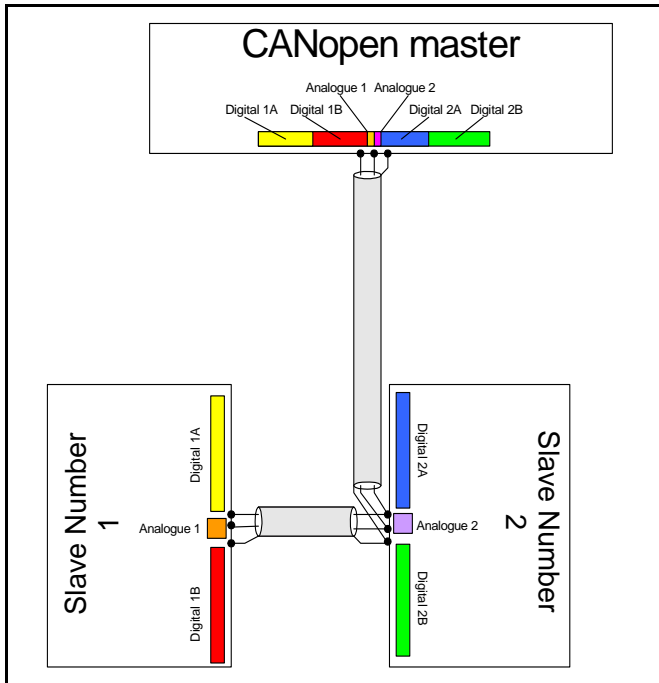

Table 2.2 details the number of data words used to communicate the signals using the CANopen network. It can be seen that the resulting reduction in cabling is significant

**Table 2.2 Data mappings for SM-CANopen**

Number of network words	Type	Source / Destination	Description
1	digital inputs	slave 1 to master	status signals
1	digital outputs	master to slave 1	control signals
1	analogue output	master to slave 1	control signal
1	digital inputs	slave 2 to master	status signals
1	digital outputs	master to slave 2	control signals
1	analogue output	master to slave 2	control signal

CANopen transfers data using two distinct modes. The first of these modes is cyclic where signals are sent in predefined blocks at regular intervals. This is the equivalent of the hard-wired example above in Figure 2-1.

The second method of transfer is called non-cyclic data (CANopen may use SDOs for non-cyclic data) and is used for sending values that only need to be changed occasionally or where the source or destination of the signal changes. This is the equivalent of a temporary patch lead that is removed after use.

## 2.2 What is SM-CANopen?

SM-CANopen is a fieldbus Solutions Module that can be fitted to the expansion slot(s) in any of the following drives to provide CANopen slave connectivity.

- Unidrive SP
- Commander SK
- Commander SX (check compatibility status prior to use).

In the case of Unidrive SP it is possible to use more than one SM-CANopen or a combination of SM-CANopen and other Solutions Modules to add additional functionality such as extended I/O, gateway functionality, or additional PLC features.

**Figure 2-3 SM-CANopen for Unidrive SP**

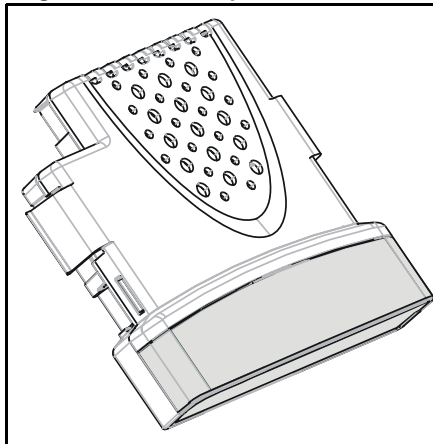

## 2.3 General specification

SM-CANopen has been designed to offer as much flexibility as possible, in particular the PDO numbering system has been specifically designed to offer maximum versatility whilst maintaining conformance to CiA specifications.

- Supported data rates (bits/s): 1M, 800K, 500K, 250K, 125K, 100K, 50K, 20K and 10K.
- Four transmit and four receive PDOs (process data objects) supported.
- Independently configurable transmit and receive PDO numbers (1-511) for maximum application flexibility.
- All synchronous and asynchronous PDO communication modes supported.
- Total of 32 bytes (16 words) in each direction using PDOs (4 TxPDOs of 64 bits and 4 RxPDOs of 64 bits).
- Custom handling of specific objects with SM-Applications/SM-Applications Lite on Unidrive SP.

- Direct mapping of PDO data to and from SM-Applications/SM-Applications Lite parameters\*.
- Service Data Objects (SDO) provide access to all drive and SM-Applications parameters\*.
- Heartbeat protocol supported to guard against loss of communications.
- Emergency object supported, with custom user handling on Unidrive SP with SM-Applications/SM-Applications Lite.
- D-type or screw terminal connections for ease of wiring.
- Synchronised data transfer, with axis synchronisation on Unidrive SP.
- +24V back-up power supply capability via the Unidrive SP.

\*Unidrive SP only feature.

## 2.4 Solutions Module identification

The SM-CANopen can be identified by:

1. The label located on the underside of the Solutions Module.
2. The colour coding across the front of the SM-CANopen (light grey).

Figure 2-4 SM-CANopen labels

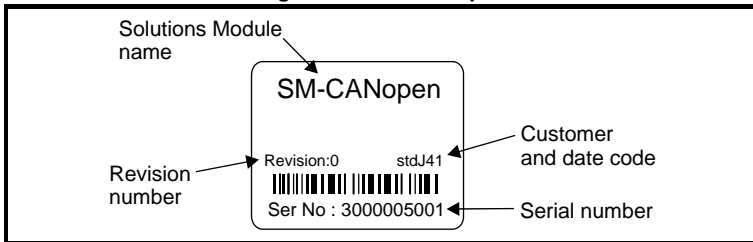

### 2.4.1 Date code format

The date code is split into two sections: a letter followed by a number.

The letter indicates the year, and the number indicates the week number (within the year) in which the Solutions Module was built.

The letters are in alphabetical order, starting with A in 1990 (B in 1991, C in 1992 etc.).

**Example:**

A date code of O35 would correspond to week 35 of year 2005.

## 2.5 Product conformance certificate

SM-CANopen has been awarded a CANopen certificate by *CAN In Automation* (CiA). A copy of the certificate is available from your supplier or local Control Techniques Drive Centre.



## 2.6 Conventions used in this guide

The configuration of the host drive and Solutions Module is done using menus and parameters. A menu is a logical collection of parameters that have similar functionality. In the case of a Solutions Module, the parameters will appear in menu 15 for the Commander SK and Commander SX, and in menu 15, 16 or 17 for the Unidrive SP depending on the slot the module is fitted into. The menu is determined by the number before the decimal point. The method used to determine the menu or parameter is as follows:

- Pr **xx.00** - signifies any menu and parameter number 00.
- Pr **MM.xx** - where MM signifies the menu allocated to the Solution Module (this could be 15, 16 or 17 on the Unidrive SP but will always be 15 on the Commander SK and Commander SX) and xx signifies the parameter number.

**NOTE** All references in this manual to SM-Applications should also extend to SM-Applications Lite. The exceptions to this are references to SM-Applications input/output, CTSync or the RS485 port, as these are not supported on SM-Applications Lite. For full details of the differences see the *Applications Modules User Guide*.

## 2.7 Conventions used for SM-CANopen

When referring to PDOs (process data objects), a PDO normally refers to both TxPDO (transmit process data object) and RxPDO (receive process data object). Where the differences are important this is quantified using the terms TxPDO and RxPDO.

SM-CANopen references PDOs by a letter (A, B,C & D) to differentiate between the configuration of the PDOs and the actual PDO numbers used. SM-CANopen supports 4 TxPDOs (A, B,C & D) and 4 RxPDOs (A, B,C & D) these PDOs have the default PDO numbers of 1, 3, 5 & 6 respectively, however these may be configured to any valid PDO number using a master.

# 3 Mechanical Installation



Before installing the Solutions Module, refer to Chapter 1 *Safety Information* on page 6.



Do not remove the Solutions Module when the drive is powered-up. This could damage the drive and/or the Solutions Module.

## 3.1 Installation

### 3.1.1 Installation on Unidrive SP

Three Solutions Module slots are available on Unidrive SP. The Solutions Module can be plugged into any of these slots but it is recommended that slot 3 be used for the first Solutions Module, then slot 2 and then slot 1. This ensures the maximum mechanical support for the Solutions Module once fitted (see Figure 3-2).

**Figure 3-1 Removing the Unidrive SP terminal cover**

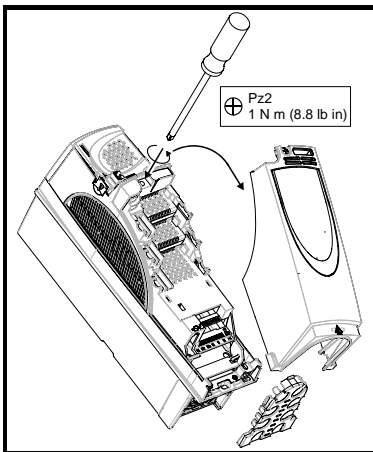

**Figure 3-2 Fitting and removing a Solutions Module into the Unidrive SP**

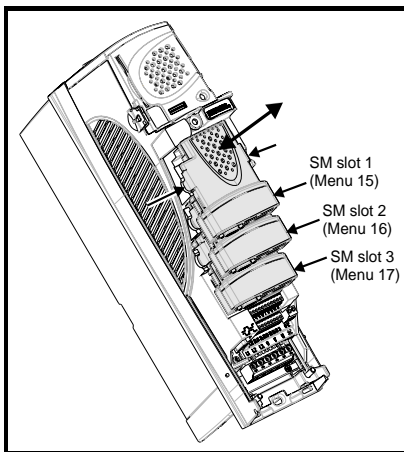

1. Before installing a Solutions Module, ensure the AC supply (or DC bus supply) has been disconnected for at least 10 minutes.
2. Ensure that any +24V and low voltage DC power supplies (if used) have been disconnected from the drive.
3. Check that the exterior of the Solutions Module is not damaged and the multiway connector on the underside of the module is free from dirt and debris.
4. Do not install a damaged or dirty Solutions Module in the drive.
5. Remove the terminal cover from the drive as shown in Figure 3-1.
6. Position the drive connector of the Solutions Module over the appropriate connector of the drive. Push the Solutions Module towards the rear of the drive until it locks into place. Make any wiring connections as appropriate (see Chapter 4 *Electrical Installation* on page 18 for additional information).

Safety Information
Introduction
<b>Mechanical Installation</b>
Electrical Installation
Getting Started
EFS Files
Cyclic Data
Non-Cyclic Data
Control and Status Words
Diagnostics
Advanced Features
CANopen Reference
Quick Reference
Glossary Of Terms
Index

7. Re-fit the terminal cover to the drive by reversing the procedure shown in Figure 3-1.
8. Connect the AC or DC bus supply to the drive.
9. When a Solutions Module is fitted for the first time, as the drive is powered-up, the drive will trip on *SL1.dF* or *SL2.dF* or *SL3.dF* depending on which slot the Solutions Module is fitted to. A parameter save must now be performed. Set Pr **xx.00** = 1000 (or 1001 in the case of solely using the 24V back-up power supply) and press the *Stop/Reset* button. If a parameter save is not performed, the drive will trip on the above trip the next time the drive is powered up.

**NOTE** When using the 24V back-up power supply only, the *SLx.dF* trip will not occur (as the drive is already displaying a *UU* trip).

**NOTE** When fitting two or more Solutions Modules simultaneously, the *SLx.dF* trip is only applicable to the module fitted in the lowest numerical slot.

**NOTE** If an *SLx.dF* trip is not seen after the first power-up, the Solutions Module is not fitted properly to the drive. Power down the drive, remove and re-fit the Solutions Module. Then power can be re-applied to the drive.

10. To access the advanced parameters refer to the *Unidrive SP User Guide*.
11. Check that Menu 15 (*slot 1*), 16 (*slot 2*), or 17 (*slot 3*) parameters are now available (*depending on which slot is used*).
12. Check that Pr **15.01**, Pr **16.01** or Pr **17.01** shows the correct code for the SM-CANopen (408).
13. Power the drive down and back up again. The Solutions Module is now ready for programming.

**NOTE** If the Solutions Module is changed for a different type, the drive will trip as in step 9. Follow the above procedure again to install the module.

14. If the checks in steps 11 and 12 fail, either the Solutions Module is not fully inserted, or it is faulty.
15. If a trip code is now present refer to Chapter 10 *Diagnostics* on page 70.

### 3.1.2 Commander SK

One Solutions Module slot is available on Commander SK. See Figure 3-4



To allow a Solutions Module to be fitted to Commander SK, a protective cover must be removed to allow access to the PCB edge connector (see Figure 3-3). This protective cover provides protection from direct contact of the PCB edge connector by the user. When this cover is removed and Solutions Module fitted, the Solutions Module provides the protection from direct contact by the user. If the Solutions Module is then removed, this PCB edge connector becomes exposed. The user is required to provide protection in this case.

**Figure 3-3 Removing the Commander SK terminal cover**

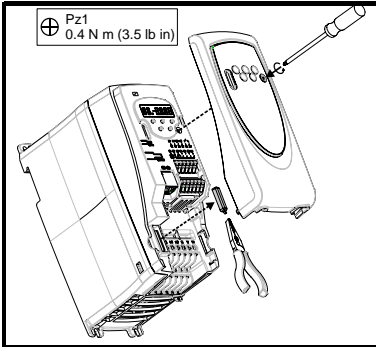

**Figure 3-4 Fitting and removing a Solutions Module into the Commander SK**

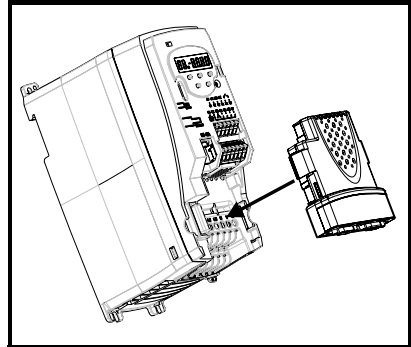

1. Before installing a Solutions Module, ensure the AC or DC bus supply has been disconnected for at least 10 minutes.
2. Ensure that any +24V and low voltage DC power supplies (if used) have been disconnected from the drive.
3. Check that the exterior of the Solutions Module is not damaged and the multiway connector on the underside of the module is free from dirt and debris.
4. Do not install a damaged or dirty Solutions Module in the drive.
5. Remove the terminal cover from the drive as shown in Figure 3-3.
6. Position the drive connector of the Solutions Module over the appropriate connector of the drive and push downwards until it locks into place. Make any wiring connections as appropriate (see Chapter 4 *Electrical Installation* on page 18 for additional information). Ensure that the plastic tab, which covers the drive's Solutions Module connector, is removed before fitting any Solutions Module (see Figure 3-4).
7. Re-fit the terminal cover to the drive by reversing the procedure shown in Figure 3-3.
8. Connect the AC or DC bus supply to the drive.
9. When a Solutions Module is fitted to a Commander SK for the first time, as the drive is powered-up, the drive will trip on SL.dF. Press the STOP/RESET button to clear the trip. The Commander SK automatically saves the Solutions Module identity details to memory which will avoid any future SL.dF trips.

Safety Information
Introduction
Mechanical Installation
Electrical Installation
Getting Started
EDS Files
Cyclic Data
Non-Cyclic Data
Control and Status Words
Diagnostics
Advanced Features
CANopen Reference
Quick Reference
Glossary Of Terms
Index

10. To access the advanced parameters refer to the *Commander SK Getting Started Guide*.

**NOTE**

If a *SL.dF* trip is not seen after the first power-up, the Solutions Module is not fitted properly to the drive. Power down the drive, remove and re-fit the Solutions Module. Then power can be re-applied to the drive.

11. Check that Menu 15 parameters are now available.

12. Check that Pr **15.01** shows the correct code for SM-CANopen (408).

13. Power the drive down and back up again. The Solutions Module is now ready for programming.

**NOTE**

If the Solutions Module is changed for a different type, the drive will trip as in step 9. Follow the above procedure again to install the module. If the checks in steps 11 and 12 fail, either the Solutions Module is not fully inserted, or it is faulty. If a trip code is now present refer to Chapter 10 *Diagnostics* on page 70.

### 3.1.3 Installation on Commander SX

One Solutions Module slot is available on Commander SX (see Figure 3-6).

**Figure 3-5 Removing the Commander SX terminal cover**

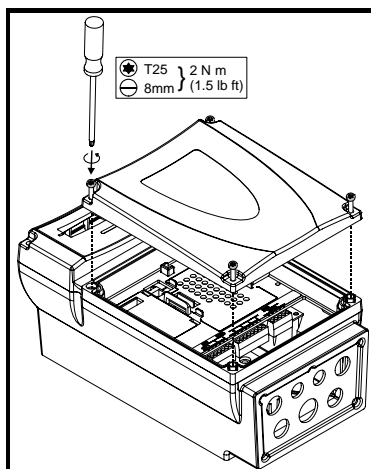

**Figure 3-6 Fitting and removing a Solutions Module into the Commander SX**

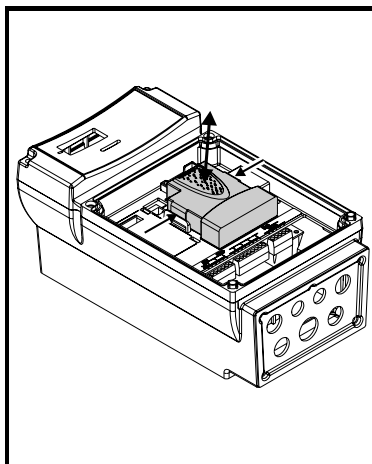

1. Before installing a Solutions Module, ensure the AC supply or DC bus has been disconnected for at least 10 minutes.
2. Ensure that any +24V and low voltage DC power supplies have been disconnected from the drive.
3. Check that the exterior of the Solutions Module is not damaged and the multiway connector on the underside of the module is free from dirt and debris.
4. Do not install a damaged or dirty Solutions Module in the drive.
5. Remove the terminal cover from the drive as shown in Figure 3-5.
6. Position the drive connector of the Solutions Module over the appropriate connector of the drive and push downwards until it locks into place. Make any wiring connections as appropriate (see Chapter 4 *Electrical Installation* on page 18 for additional information).
7. Re-fit the terminal cover to the drive by reversing the procedure shown in Figure 3-5

8. Connect the AC supply or DC bus to the drive.
9. When a Solutions Module is fitted to a Commander SX for the first time, as the drive is powered-up, the drive will trip and flash alternatively between display codes FbUS and triP. Press the STOP/RESET button to clear the trip.
10. The Commander SX automatically save the Solutions Module identity details to memory, which will avoid any future trips.
11. To access the advanced parameters refer to the *Commander SX User Guide*.
12. Check that Menu 15 parameters are now available.
13. Check that Pr **15.01** shows the correct code for the SM-CANopen: 408
14. Power the drive down and back up again. The Solutions Module is now ready for programming.

**NOTE**

If the Solutions Module is changed for a different type, the drive will trip as in step 9. Follow the above procedure again to install the module. If the checks in steps 11 and 12 fail, either the Solutions Module is not fully inserted, or it is faulty. If a trip code is now present refer to Chapter 10 *Diagnostics* on page 70.

**NOTE**

If a trip is not seen after the first power-up, the Solutions Module is not fitted properly to the drive. Power down the drive, remove and re-fit the Solutions Module. The power can then be reapplied to the drive.



**CAUTION**

The Commander SX features may differ significantly to those described for SP and SK. In the case of doubt always consult your supplier or local drive centre.

Safety Information
Introduction
<b>Mechanical Installation</b>
Electrical Installation
Getting Started
EPS Flashes
Cyclic Data
Non-Cyclic Data
Control and Status Words
Diagnostics
Advanced Features
CANopen Reference
Quick Reference
Glossary Of Terms
Index

## 4 Electrical Installation

### 4.1 SM-CANopen terminal descriptions

SM-CANopen has a standard 5-way screw terminal block connector (shown on the right) for the CANopen network. The 9-way male D-type may also be used to connect to SM-CANopen. These connectors are detailed in the CANopen specification.

Figure 4-1 SM-CANopen - front view

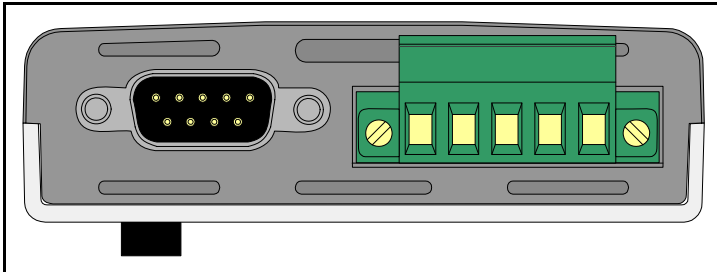

The terminals are numbered from 1-5 reading from left to right (see Figure 4-2).

Table 4.1 SM-CANopen terminal descriptions

5-way terminal	D-type terminal	Function	Description
1	6	0V	0V CANopen external supply (optional)
2	2	CAN-L	Negative data line
3	3,5 Shell	Shield	Cable braided shield connection
4	7	CAN-H	Positive data line
5	9	+24V	+24V CANopen external supply (optional)

**NOTE** The external supply terminals provide power for the CAN transceiver circuitry, but do NOT provide power to keep SM-CANopen operating in the event of the mains power supply loss to the drive. An external supply will keep the CAN transceivers powered up and the network load characteristics constant in the event of loss of power to the drive.



Any external supply must be suitably installed to prevent noise on the network. Pins 1 and 5 are not required by the CANopen network and it is recommended that they are not connected. Connecting pins 1 and 5 to an external supply allows the line driver circuitry to remain powered when the drive and the CANopen module are turned off. This 24V input does not allow SM-CANopen to continue communicating.

## 4.2 SM-CANopen connections

To connect SM-CANopen to the CANopen network, make the connections as shown in the diagram below. The length of the "pigtail" shield connection should be kept as short as possible in order to keep noise to a minimum.

Figure 4-2 SM-CANopen connections

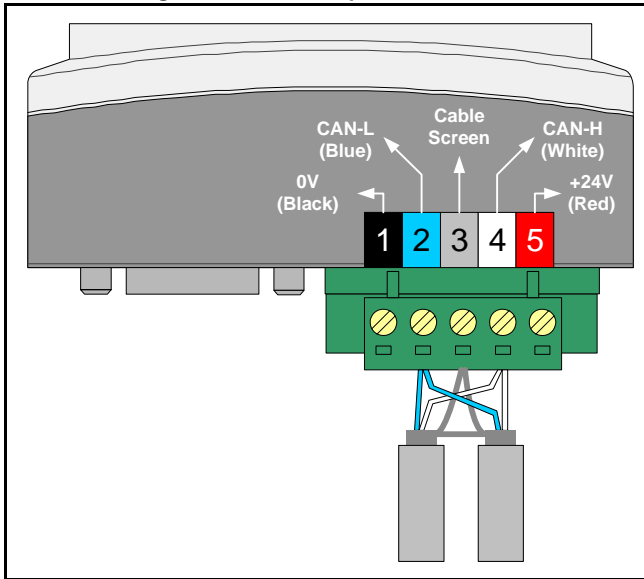

## 4.3 CANopen cable

CANopen cable has a single twisted pair with overall shielding. CANopen-H has a specified colour code and it is strongly recommended that this is adhered to.

Table 4.2 CANopen cable colour codes

Cable	Data signal	Terminal	Description
Blue	CAN-L	2	Negative data line
Braided shield	Shield	3	Cable shield
White	CAN-H	4	Positive data line

CANopen networks run at high data rates and require cable specifically designed to carry high frequency signals. Low quality cable will attenuate the signals, and may render the signal unreadable for the other nodes on the network. Cable specifications and a list of approved manufacturers of cable for use on CANopen networks is available on the CAN In Automation (CiA) CANopen web site at [www.can-cia.de](http://www.can-cia.de).



Control Techniques can only guarantee correct and reliable operation of SM-CANopen if all other equipment installed on the CANopen network (including the network cable) and external supply connections have been approved by CAN In Automation.

## 4.4 CANopen network termination

It is very important with CANopen that the network communications cable is fitted with the specified termination resistor network at each end of the cable segment. This prevents signals from being reflected back down the cable and causing interference. Termination resistors (120Ω 0.25W) should be fitted across the CAN-H and CAN-L lines at BOTH ends of a network segment, as shown in the diagram below.

Figure 4-3 CANopen network termination

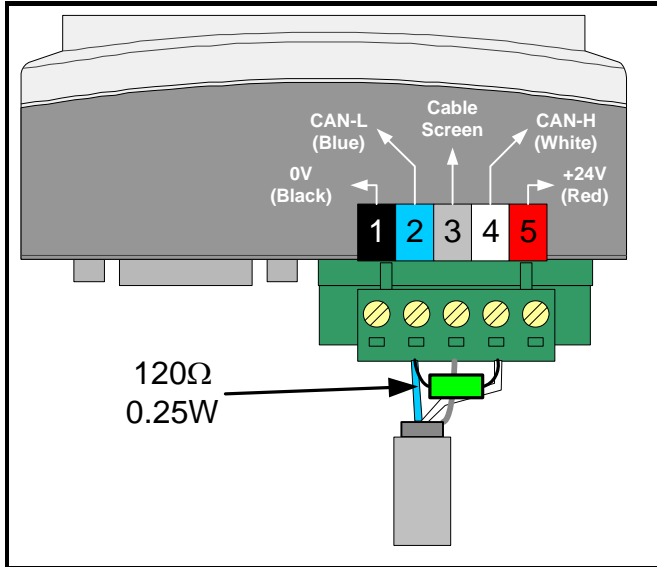

Failure to terminate a network correctly can seriously affect the operation of the network. If the correct termination resistors are not fitted, the noise immunity of the network is greatly reduced. If too many termination resistors are fitted on a CANopen network, the network will be over-loaded, causing reduced signal levels which will result in potential transmission errors.

## 4.5 SM-CANopen cable shield connections

SM-CANopen should be wired with the cable shields isolated from ground at each drive. The cable shields should be linked together at the point where they emerge from the cable, and formed into a short pigtail to be connected to pin 3 on the CANopen connector as shown in Figure 4-2.

### NOTE

The CANopen cable can be tie-wrapped to the grounding bar or a local convenient fixing point that is not live to provide strain relief, but the CANopen cable shield **must** be kept isolated from ground at each node. The only exception to this is the CANopen ground point. Refer to section 4.6 *CANopen ground point* on page 21.

## 4.6 CANopen ground point

The CANopen ground point is the place on a network segment where the cable screen is grounded for electrical safety.



The CANopen cable shield must be grounded AT ONE POINT only, usually near the centre point of the cable run. This is to prevent the cable shield from becoming live in the event of catastrophic failure of another device on the CANopen network. The CANopen ground point is for electrical safety and should not be omitted.

## 4.7 Using the drive as a ground point

### 4.7.1 Unidrive SP

When using a Unidrive SP node as the desired ground point, the shield of one of the CANopen cables can be exposed and clamped to the Grounding Bar, as shown in Figure 4-4 below.

Figure 4-4 CANopen ground point on the Unidrive SP

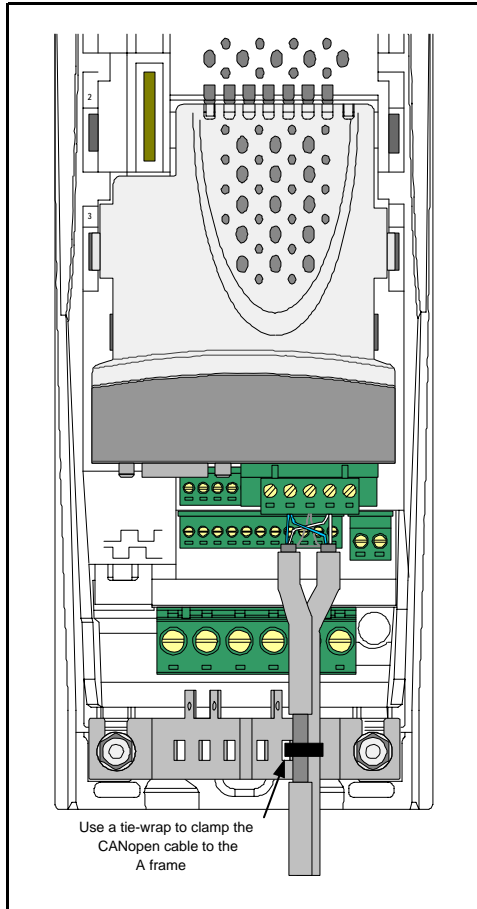

**NOTE** Care should be taken when clamping cables to avoid damage to the cable.

#### 4.7.2 Commander SK

When using a Commander SK as the network grounding point it is recommended that the earthing bracket part number 6541-0036-00 is used. The network cable can then be connected to ground using appropriate clamps (not supplied), or alternatively, tied to the bracket using cable ties (see Figure 4-5).

Figure 4-5 SK-Bracket

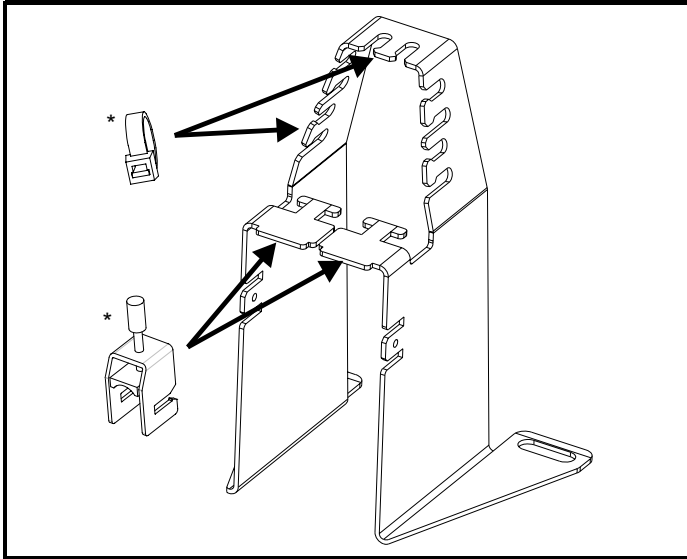

**NOTE** Care should be taken when clamping cables to avoid damage to the cable.

### 4.7.3 Commander SX

When using a Commander SX as the network grounding point, connection of the network screen can be performed with suitable glands on the gland plate or by clamping the cable as close to the drive grounding point as possible (see Figure 4-6).

Figure 4-6 Commander SX shield connections

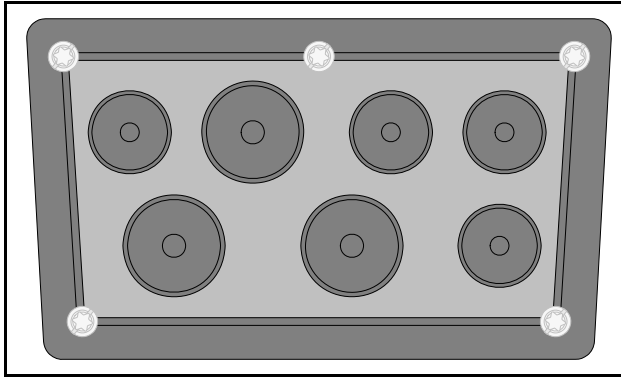

**NOTE** Care should be taken when clamping cables to avoid damage to the cable.

### 4.8 Unidrive SP: SM-CANopen back-up power supply

If the CANopen network is required to continue operating in the event of a loss of the mains supply to the Unidrive SP, a back-up +24V power supply should be connected directly to the Unidrive SP. All option modules draw their power from the Unidrive SPs internal power supply and this will ensure that SM-CANopen will continue to communicate in the event of mains supply loss.

**NOTE** The external power supply pins on the SM-CANopen connectors will NOT keep the SM-CANopen module powered up. These pins only supply power to the CAN transceiver circuitry (with a maximum current drawn of 10mA). The external power supply should be suitably installed so as to prevent external noise entering the drive.

Safety Information
Introduction
Mechanical Installation
<b>Electrical Installation</b>
Getting Started
EDS Files
Cyclic Data
Non-Cyclic Data
Control and Status Words
Diagnostics
Advanced Features
CANopen Reference
Quick Reference
Glossary Of Terms
Index

## 4.9 Maximum network length

The maximum number of nodes that can be connected to a single CANopen network segment is 32. The maximum length of network cable for a CANopen network is dependant on the data rate used (see Table 4.3).

**Table 4.3 CANopen maximum segment lengths**

Data rate (bits/sec)	Maximum network length (m)
1M	30
800K	50
500K	100
250K	250
125K	500
100K	700
50K	1000
20K	2500
10K	5000

## 4.10 Spurs

Control Techniques do not recommend the use of spurs on a CANopen network. For more detailed information please consult the CiA at [www.can-cia.org](http://www.can-cia.org).

## 4.11 Minimum node to node cable length

The CANopen specification does not specify a minimum node to node distance, however, Control Techniques advises a minimum distance of 1m between nodes to prevent excessive mechanical stress and to reduce network reflections.

# 5 Getting Started

This section is intended to provide a generic guide for setting up SM-CANopen and a master controller/PLC. Figure 5-2 *Installation and addressing* on page 31 is intended as the starting point for a new installation. The following pages detail the various methods available to configure SM-CANopen. It is recommended that all of this section is read, before attempting to configure a system. Table 5.1 shows the different versions of drive firmware required to use SM-CANopen.

**Table 5.1 SM-CANopen version compatibility**

Drive Type	Drive Firmware	SM-CANopen Firmware
Commander SK	Version 01.02.00 or later.	Version 03.00.01 or later.
Commander SX	Version 02.01.00 to Version 03.00.00 or later.	Version 02.00.00.
	Version 3.00.00 or later.	Version 02.00.00 or later.
Unidrive SP	Version 01.00.00 or later.	Version 01.00.01 or later.

**NOTE** It is strongly recommended that the latest firmware is used where possible to ensure all features are supported.

**NOTE** Due to the large number of different PLCs/masters that support CANopen, details cannot be provided for a specific master or PLC. Generic support is available through your supplier or local drive centre. Before contacting your supplier or local drive centre for support ensure you have read Chapter 10 *Diagnostics* on page 70 of this manual and check you have configured all parameters and SDOs correctly.

Ensure the following information is available before calling:

- A list of all parameters in SM-CANopen.
- The drive firmware version (*see the drive documentation*).
- A list of any SDOs used for configuration.
- The system file version of SM-Applications (*see the Applications Modules User Guide for more information*).

Safety Information
Introduction
Mechanical Installation
Electrical Installation
<b>Getting Started</b>
EDS Files
Cyclic Data
Non-Cyclic Data
Control and Status Words
Diagnostics
Advanced Features
CANopen Reference
Quick Reference
Glossary Of Terms
Index

## 5.1 SM-CANopen node address

SM-CANopen node address		
Pr MM.03	Default	0
	Range	0 to 127
	Access	RW

Every node on a CANopen network must be given a unique network node address. If two or more nodes are assigned the same node address, network errors may result as 2 nodes attempt to transmit at the same time. The valid range for the node address is 0 to 127, with a default address of 0. SM-CANopen must be reset to make a change of node address take effect (see section 5.12 *Resetting the SM-CANopen (re-initialising)* on page 43).

**NOTE** If an invalid node address is set, SM-CANopen will over-write the value in Pr **MM.03** with 0. When SM-CANopen is reset, this value will be used as the node address. A node address of 0 will disable the CANopen communications layer but the DSP305 V1.1 Layer Setting Service (LSS) will still be active. Refer to section 12.10 *Network management objects (NMT)* on page 127 for further details.

## 5.2 SM-CANopen data rate

SM-CANopen data rate		
Pr MM.04	Default	2 (500kb/s)
	Range	-1 to 8
	Access	RW

Every node on a CANopen network must be configured to run at the same network data rate. If a node is configured with the wrong data rate, it may cause errors on the CANopen network and eventually trip on “SLx.Er” (with error code of 66). SM-CANopen must be reset to make a change of data rate take effect (see section 5.12 *Resetting the SM-CANopen (re-initialising)* on page 43).

**Table 5.2 SM-CANopen data rates**

Pr MM.04	bits/s		Pr MM.04	bits/s
-1	Auto		4	125K
0	1.0M		5	100K
1	800K		6	50K
2	500K		7	20K
3	250K		8	10K

### 5.2.1 Automatic data rate detection

SM-CANopen may be configured to automatically detect the network data rate by setting Pr **MM.04** to -1. SM-CANopen will monitor the CANopen network, and if the data rate is detected, it will set Pr **MM.04** to the indicate the detected data rate. However, it should be noted that the new value of Pr **MM.04** will NOT be stored.

The recommended sequence of events using auto-detection of the data rate as follows:

1. Power up the drive
2. Set Pr **MM.04** to -1
3. Reset SM-CANopen by setting Pr **MM.32** to ON.
4. Connect SM-CANopen to the CANopen network.
5. Wait for Pr **MM.04** to change from -1.

6. Store the Unidrive SP/Commander SK parameters by setting Pr **MM.00** to 1000 and pressing RESET. For the Commander SX store the parameters by pressing the M key.

**NOTE**

SM-CANopen will not be able to reliably detect the network data rate if there is little or no traffic on the network. Auto detection of the data rate is ideal when connecting a new node to an existing network, but may not work reliably if a network is powered up with all nodes attempting to detect the data rate.

## 5.3 Flexible PDO Numbering (software compatibility)

Different software versions handle PDO configuration with varying degrees of flexibility, as detailed below.

### 5.3.1 Software versions prior to V02.01.00

The PDO numbering scheme is fixed and cannot be changed. The PDOs available are TxPDOs 1,3,5 & 6 and RxPDOs 1,3,5 & 6.

### 5.3.2 Software version 02.01.00

PDO1 is fixed and cannot be changed. To configure up to 3 additional PDOs all that is required is to set up the PDO using SDOs at network start-up. This is the same procedure as for previous firmware releases using PDOs 3, 5 and 6 but uses the object number for the new PDO during set-up (i.e. base address + PDO number -1). A maximum of 4 PDOs are allowed and all, apart from PDO1 may be set up to any PDO in the range 0x002-0x1FF. TxPDO and RxPDO numbering is independent. If additional PDOs are mapped an error message will be produced as only the first 3 additional mappings will be accepted by SM-CANopen. To summarise, the first 3 additional PDOs that are configured will be added to SM-CANopen giving a total of 4 PDOs in each direction.

### 5.3.3 Software versions 03.01.01 and later

The default pre-defined PDO numbers for both TxPDOs and RxPDOs remain as 1,3,5 and 6. However, new objects 0x2800 and 0x2801 have been added to allow both TxPDOs and RxPDOs to be re-numbered. This allows 4 PDOs to be configured in each direction, these are referred to as PDOs A,B,C & D as the actual numbers may be changed. Any changes to PDO numbering can only be achieved using objects 0x2800 and 0x2801.

## 5.4 PDO number configuration

If a master dictates the changing of a PDO number for a specific sub-index in object 0x2800 or 0x2801, doing this will result in the existing PDO configuration objects being destroyed and objects for the new PDO being created with default values, and will take effect immediately. If the PDO number is already used within the same object the old PDO will be overwritten. It is now possible to have different numbers for individual TxPDOs and RxPDOs eg. TxPDO 1,2,3,4 and RxPDO 5,6,7,8.

### 5.4.1 Object 0x2800 (RxPDO number configuration)

**Sub Index 0** : Will return 4 when read indicating the maximum sub-index and number of PDOs supported.

**Sub Index 1 – 4** : Are used to read and set the RxPDO number for each of the 4 configurable RxPDOs. The number is specified as the required number less 1. That is, PDO1 would be represented as 0.

Safety Information
Introduction
Mechanical Installation
Electrical Installation
Getting Started
EDS Files
Cyclic Data
Non-Cyclic Data
Control and Status Words
Diagnostics
Advanced Features
CANopen Reference
Quick Reference
Glossary Of Terms
Index

## 5.4.2 Object 0x2801 (TxPDO number configuration)

**Sub Index 0** : Will return 4 when read indicating the maximum sub-index and number of PDOs supported.

**Sub Index 1 – 4** : Are used to read and set the TxPDO number for each of the 4 configurable TxPDOs. The actual index number is calculated by subtracting 1 from the PDO number and adding this number to the base address e.g. for 0x1600 PDO3 = 0x1602.

## 5.5 PDO structure (PDOs A,B,C & D)

SM-CANopen provides 4 TxPDOs and 4 RxPDOs these are referred to as PDOs A,B,C & D, by default these are configured as PDOs 1,3,5 & 6 respectively. PDOA (by default PDO1) may be configured entirely from the Pr **MM.xx** (SM-CANopen) parameters without the need for a master. The remaining PDOs (B,C & D) which by default are allocated to PDOs 3,5 & 6 respectively, require a master to configure them using SDOs (PDOA may also be configured with a master). The benefits of using this scheme are that it allows the 4 PDOs (A,B,C,D) to be configured to any valid PDO number required whilst still achieving conformance.

## 5.6 Types of set-up

SM-CANopen offers several different methods of configuration that depend on the number of PDOs required and the type of master involved.

### 5.6.1 Configuration by SM-CANopen parameters only (no master, single PDO)

A single PDO (PDOA) may be configured by using the Pr **MM.xx** (SM-CANopen) parameters alone. The default setting for the first PDO (PDOA) is TxPDO 1 and RxPDO1. All settings such as transmission type, TxPDO length, RxPDO length, TxPDO mappings and RxPDO mappings can be configured directly from the menu associated with SM-CANopen. This allows simple configuration, but is restricted to a single PDO.

**NOTE** The default transmission type, asynchronous timer trigger (type 255) for TxPDOA cannot be configured without a master, as the SM-CANopen internal timer must be configured to use this feature. For use without a master the transmission type should be changed. This default configuration prevents a partially configured node from transmitting on the network.

### 5.6.2 Configuration using the pre-configured PDOs by SDO (master required)

The default SM-CANopen configuration supports PDOs A,B,C & D set to PDOs 1,3,5 & 6 respectively. In order to use all of these PDOs the configuration of the PDOs must be performed by the master (using SDOs) when the network starts.

### 5.6.3 Flexible PDO numbering (master required)

SM-CANopen provides a special method of reconfiguring the available PDOs while still maintaining conformance (objects 0x2800 and 0x2801). This method allows 4 TxPDOs (A,B,C & D) and 4 RxPDOs (A,B,C & D) to be configured individually to any valid PDO number. It is not necessary for the TxPDOs and RxPDOs to have the same PDO numbers, thus allowing for absolute flexibility during configuration. The configuration objects for the configured PDOs are taken from the base address of the object (eg. 0x1800) plus the configured PDO number minus 1 (e.g. PDO2 would use 0x1801).

**NOTE** If an SDO overwrites the settings made in Pr **MM.xx** (SM-CANopen) then the values for the communications objects will be changed, however the values stored in the parameters will not be altered. To indicate that SDOs have changed the configuration of SM-CANopen, Pr **MM.05** will show a value of 300.

**NOTE** For SM-CANopen firmware 03.01.00 and above, any modifications to the standard configuration for PDOA performed over the SDO protocol will result in the mode parameter (Pr **MM.05**) being set to 300.

### 5.6.4 SDO saving

A method for saving the configured PDOs is available by using a special object (0x1010), which allows all communication settings to be stored in SM-CANopen. This allows SM-CANopen to retain the settings sent by the configuration SDOs from the master. The node is then able to resume communications without requiring the SDO configuration to be re-sent by the master, following a reset or loss of power. This procedure does not replace a drive parameter save.

### 5.6.5 Pre-configuration for a machine (master required initially)

The SDO saving option (0x1010) allows SM-CANopen to be pre-configured on a master before use on a system. This allows the product to be configured for use with a master that does not support SDO configuration of the slave device, or a master that requires a specific set of PDO numbers. This effectively allows the module to be pre-configured before installation and allows SM-CANopen to work in existing hardware configurations with different PDO numbering schemes.

## 5.7 Configuration overview

Figure 5-1 *PDO Configuration overview* on page 30 gives an overview of the configuration process required for SM-CANopen communication objects, details are given for the key stages of set-up. In particular the stages involved in configuring PDO numbers (if required) and the required set-up parameters and objects are shown. Additional details of the objects can be found in the sections relating to the specific objects. It is recommended that all of this section is read before configuring SM-CANopen. This overview is supplemented by the set-up flowcharts that follow.

**Figure 5-1 PDO Configuration overview**

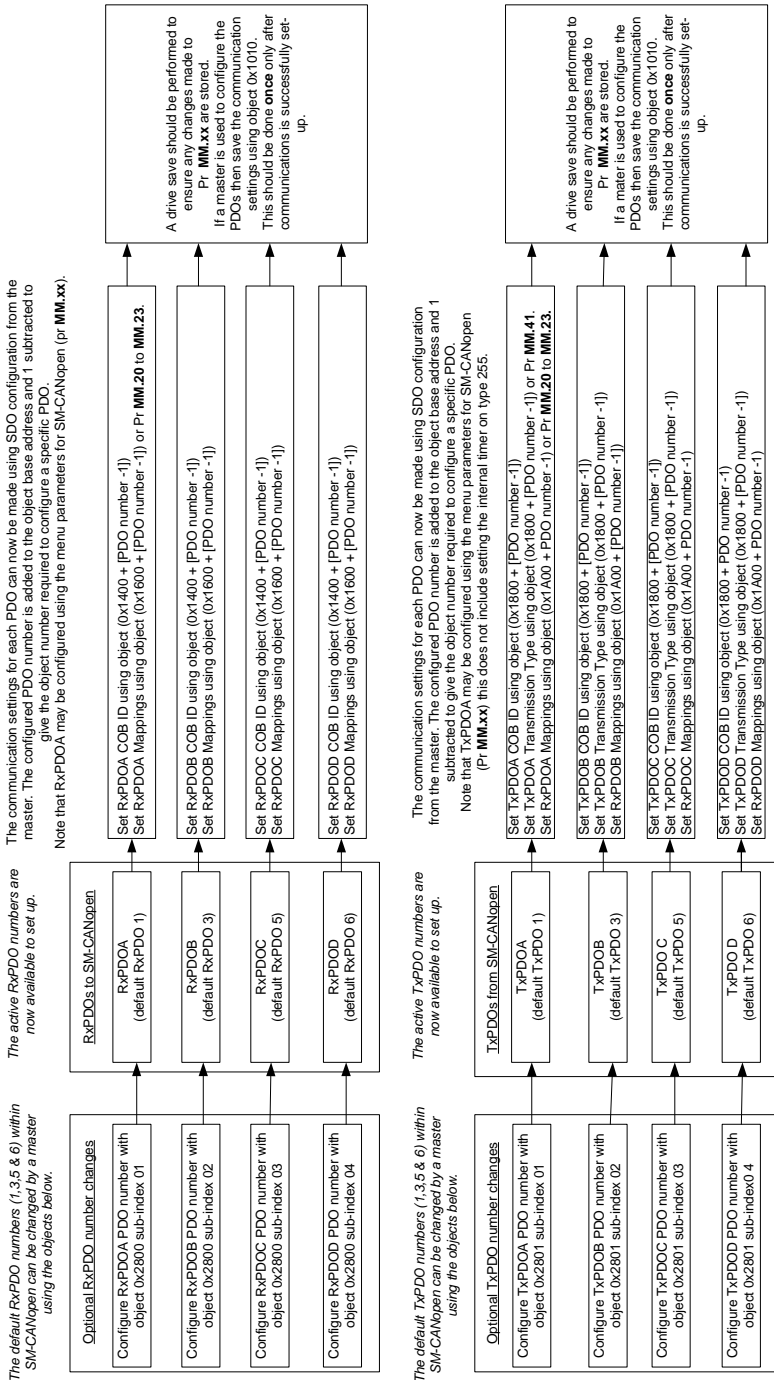

## 5.8 Setup flowcharts

The following flowcharts should be used as a visual reference to aid with the configuration of a generic network. Various options are highlighted by decision boxes and sub flowcharts are used to extend the detail within certain sections.

### 5.8.1 Cabling and addressing flowchart

Figure 5-2 details the requirements for cabling and addressing. This flowchart should be used as the starting point for all configurations.

**Figure 5-2 Installation and addressing**

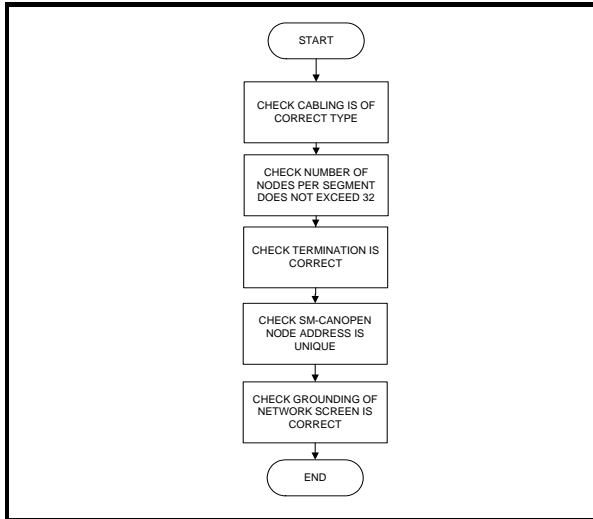

## 5.8.2 Configuring SM-CANopen

Figure 5-3 details the main setup procedure for the PDO settings on SM-CANopen. To break the procedure into manageable sections, additional sub flowcharts are referred to that expand the detail where necessary (always return to this flowchart after completion of a sub flowchart).

**Figure 5-3 Configuration Options Flowchart**

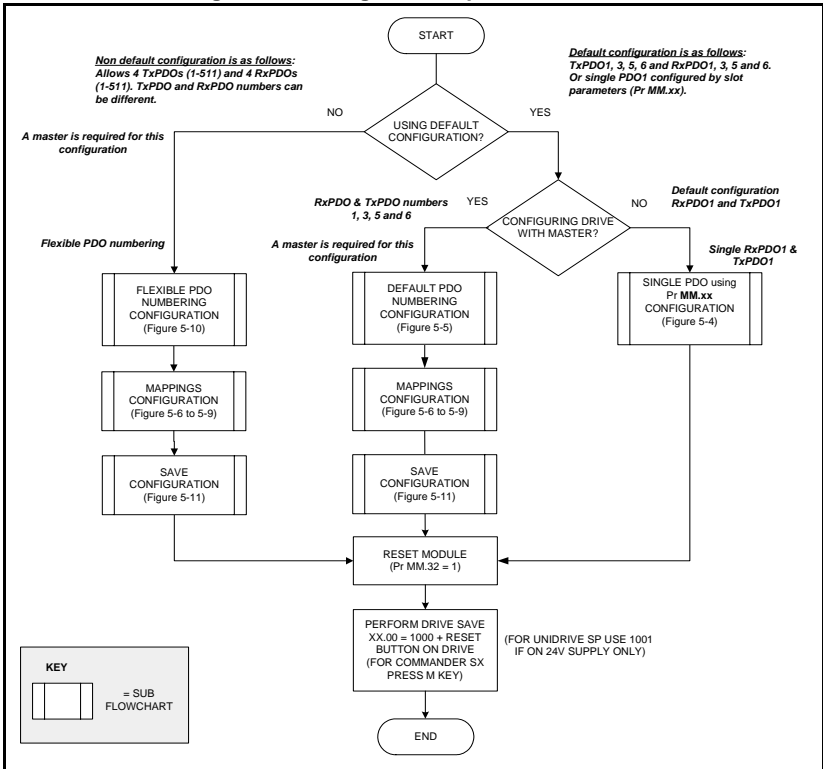

### 5.8.3 Single PDO configuration using drive parameters

Figure 5-4 details the steps required to configure SM-CANopen for a single PDO (PDO which by default is 1) using only the drive menus. This means for a single PDO1 SM-CANopen does not require a master to configure PDO1. The default PDOs in the module are RxPDO 1, 3, 5 and 6.

**Figure 5-4 Manual Configuration Flowchart**

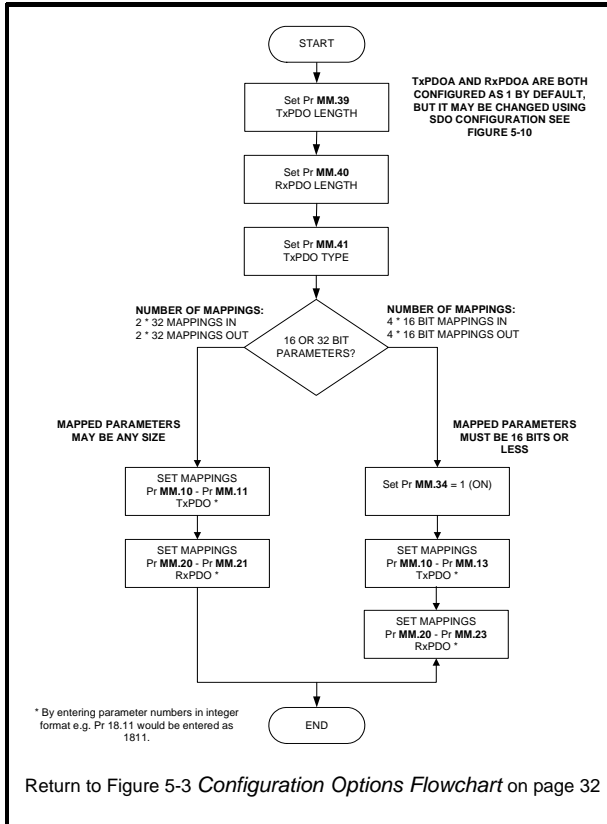

**NOTE** This chart is used in conjunction with Figure 5-3 *Configuration Options Flowchart* on page 32.

## 5.8.4 Configuration of default PDOs

Figure 5-5 details the SDOs required to setup the default RxPDOs and TxPDOs contained within the module. The default PDOs in the module are RxPDOs 1, 3, 5 and 6 and TxPDOs 1, 3, 5 and 6.

**Figure 5-5 Sub flowchart for default PDO numbering**

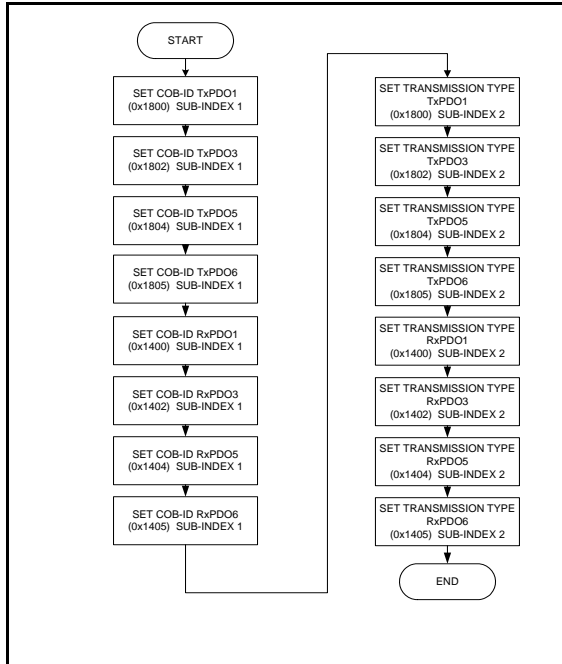

**NOTE**

This chart is used in conjunction with Figure 5-3 *Configuration Options Flowchart* on page 32.

## 5.8.5 Mapping Configuration of PDOs

This diagram shows the configuration of the mappings for PDOs. This is performed using the SDOs shown below. The route through this flowchart will be determined by the size of the parameters that are mapped.

**Figure 5-6 Mapping Configuration Flowchart [1]**

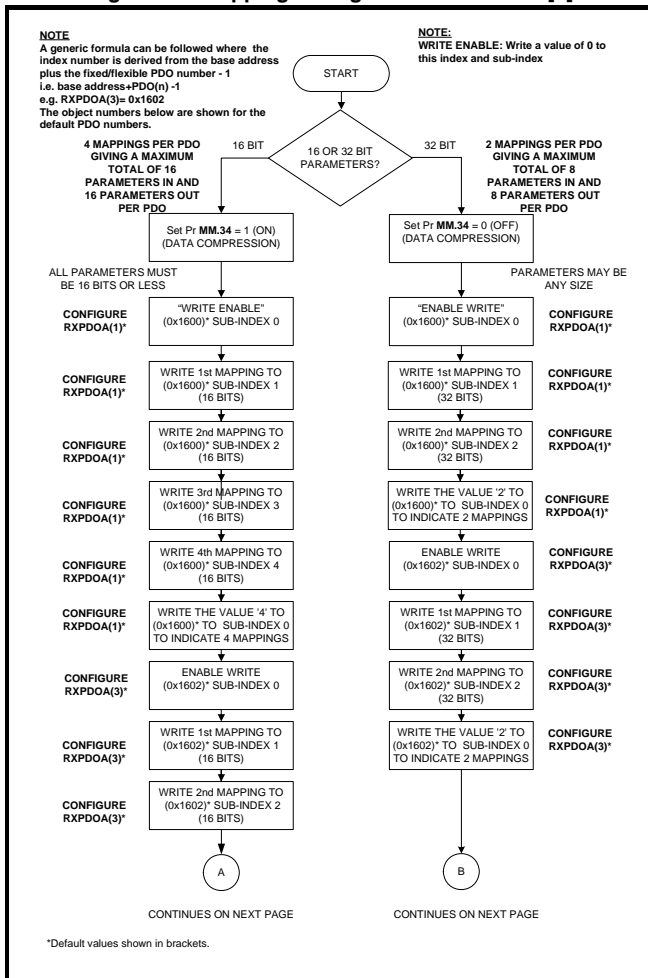

**NOTE** Setting Pr MM.34 to a 1 (data compression on) will allow a maximum of 4 mappings. If data compression is off, or the parameters are 32 bits, then only 2 mappings will be possible (i.e. each PDO has 64 bits, so the size of the parameters mapped will determine the maximum number of mappings). PDOs A,B,C & D may be configured to any valid PDO number and the TxPDO and RxPDO numbers are independent. The default configuration for PDOA, B, C & D are PDO numbers 1, 3, 5 & 6 respectively.

**NOTE** This chart is used in conjunction with Figure 5-3 *Configuration Options Flowchart* on page 32.

**Figure 5-7 Mapping Configuration Flowchart [2]**

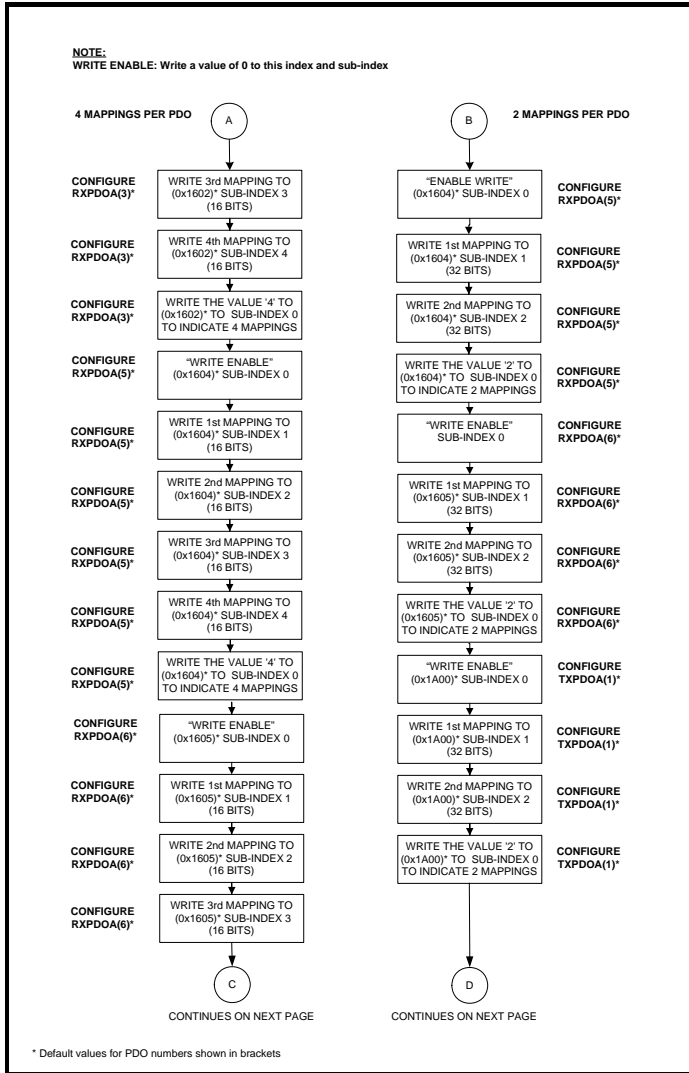

**NOTE** PDOs A,B,C & D may be configured to any valid PDO number, TxPDO and RxPDO numbers are independent. The default configuration for PDOA,B,C & D are PDO numbers 1, 3, 5 and 6 respectively, the default configuration uses the same numbers for both TxPDOs and RxPDOs, although this is not a requirement.

**NOTE** This chart is used in conjunction with Figure 5-3 *Configuration Options Flowchart* on page 32.

**Figure 5-8 Mapping Configuration Flowchart [3]**

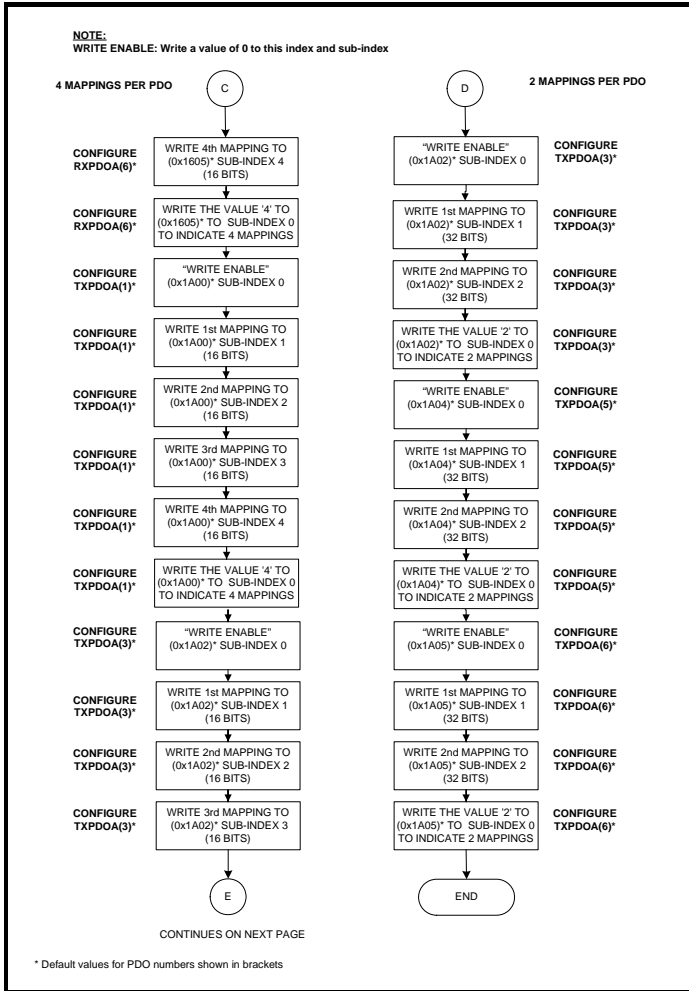

**NOTE** PDOs A,B,C & D may be configured to any valid PDO number, TxPDO and RxPDO numbers are independent. The default configuration for PDO A,B,C & D are PDO numbers 1, 3,5 & 6 respectively. the default configuration uses the same numbers for both TxPDOs and RxPDOs, although this is not a requirement.

**NOTE** This chart is used in conjunction with Figure 5-3 *Configuration Options Flowchart* on page 32.

**Figure 5-9 Mapping Configuration Flowchart [4]**

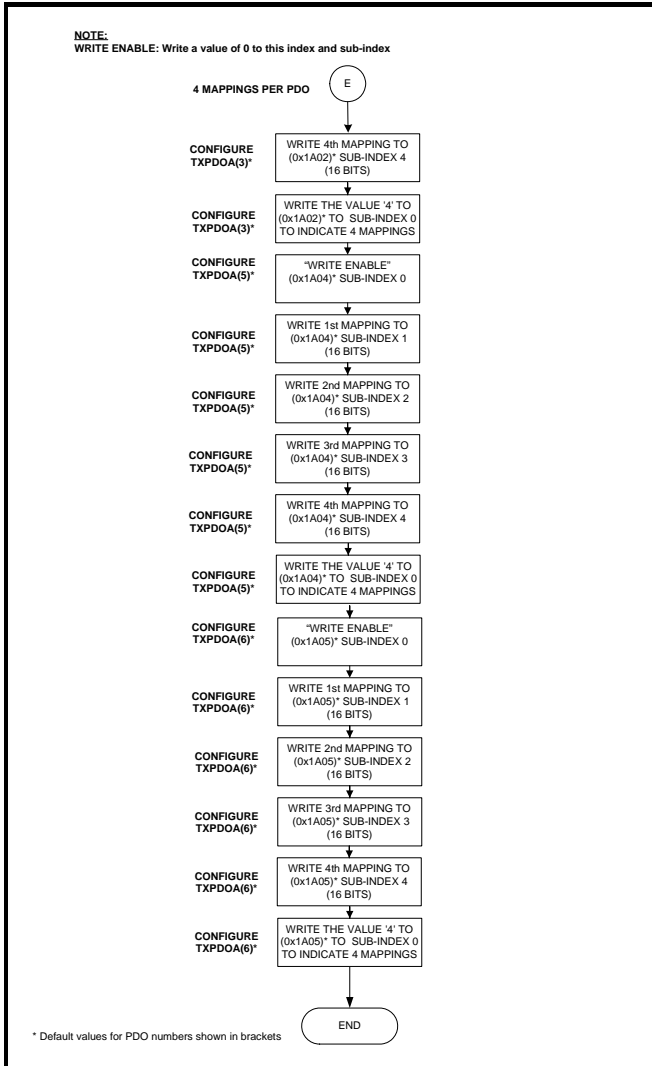

**NOTE** PDOs A,B,C & D may be configured to any valid PDO number, TxPDO and RxPDO numbers are independent. The default configuration for PDO A,B,C & D are PDO numbers 1,3,5 & 6 respectively. The default configuration uses the same numbers for both TxPDOs and RxPDOs, although this is not a requirement.

**NOTE** This chart is used in conjunction with Figure 5-3 *Configuration Options Flowchart* on page 32

## 5.8.6 Flexible PDO configuration

Figure 5-10 details the stages required to configure SM-CANopen to use custom PDO numbering (any valid PDO number from 1 to 511 may be configured). The required PDO numbers for TxPDO A,B,C & D and RxPDO A,B,C & D are written to the configuration objects shown below (the actual value written is the PDO number minus 1).

Figure 5-10 SDO Configuration

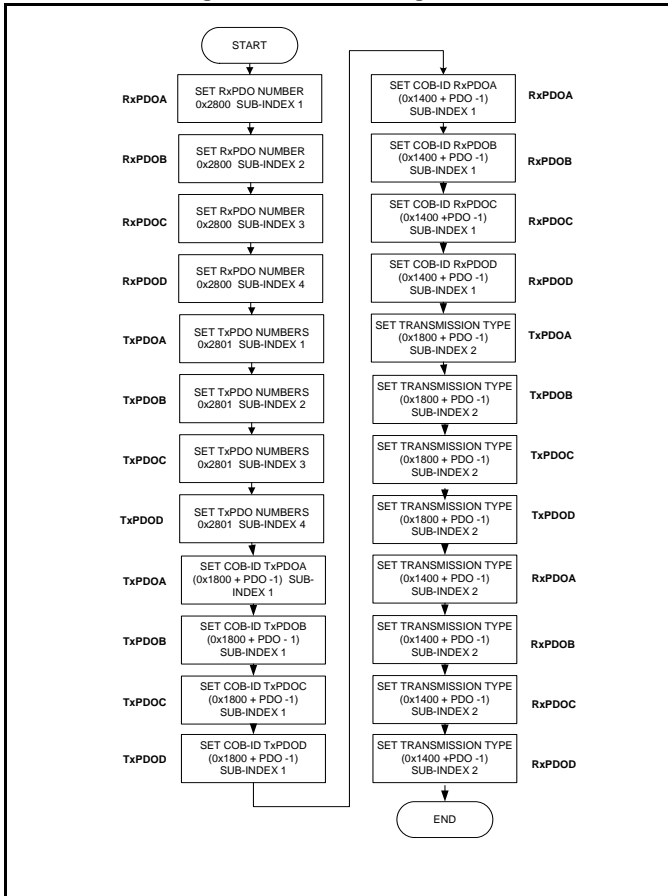

**NOTE** This chart is used in conjunction with Figure 5-3 *Configuration Options Flowchart* on page 32.

The object references in Figure 5-10 (e.g. object 0x1400) are the base addresses for the communication objects. The actual object must be calculated by adding the PDO number configured for PDO (A,B,C or D) to the base address and then subtracting 1.

To set TxPDOA to PDO number 3, Sub-index 1 of object 0x2801 should be set to 2. To set the COB ID for TxPDO 3, object 0x1802 sub-index 1 should be written to. This example configuration sets TxPDOA to TxPDO 3, then configures the transmission type using the SDO configuration for TxPDO3 (i.e. the TxPDO is configured as normal).

### 5.8.7 Saving SDO setup in SM-CANopen

Figure 5-11 details the procedure to save previously sent SDO configuration settings to the SM-CANopen FLASH memory. This removes the requirement to resend configuration SDOs if the CANopen is reset or powered down.

Figure 5-11 Saving SDO setup

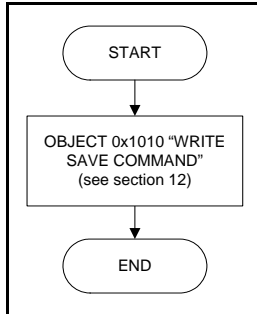

### 5.8.8 Masters with no SDO configuration facility or fixed PDOs

Some masters do not support SDO configuration of communication objects or may only support fixed PDO numbers. In this case it may be possible to use an alternative master to configure the module, and performing a save (using object 0x1010) section 12.3.8 *Store parameters* on page 110. This allows pre-configured CANopen models to be shipped to site after previously being configured. Please see Figure 5-12 for an example SDO configuration.

Figure 5-12 SDO configuration

Obj. idx	Sub. idx	Length	Value (dec)	Value (hex)
0x2801	2	2	1	0x1
0x1801	1	4	672	0x2A0
0x1801	2	1	1	0x1
0x1010	1	4	1702257011	0x65766173
0x1800	5	2	20	0x14
0x1a01	0	1	0	0x0
0x1a01	1	4	538187040	0x20141520
0x1a01	0	1	1	0x1

max. SDOs in Send Queue: 5      max. Boot-Up Timeout (s): 0  
max. SDO Timeout (s): 2

Append...    Insert...    Delete...    Edit...

## 5.9 SM-CANopen data format

SM-CANopen data format PDOA (by default PDO1)		
Pr <b>MM.05</b>	Default	4
	Range	0 - 4, 100 - 103 & 300*
	Access	RW

This parameter specifies the number of data words in the RxPDO and TxPDO for the first configured PDO (by default PDOA). To specify different lengths for RxPDO and TxPDO Pr **MM.39** and Pr **MM.40** should be used.

**NOTE** \*For SM-CANopen firmware 03.01.00 and above, any modifications to the standard configuration for PDOA performed over the SDO protocol will result in the mode parameter (Pr **MM.05**) being set to 300.

By default, RxPDOA and TxPDOA are enabled (transmission type 255) with all other PDOs disabled. TxPDOA and RxPDOA consist of two 32-bit channels each, with each channel mapped directly to a drive parameter. Default mappings as shown in Table 5.3.

**NOTE** TxPDOA and RxPDOA are set to RxPDO1 and RxPDO 1 by default. This parameter will not be used if SM-CANopen is configured by SDOs, in this case a value of 300 will be shown.

**Table 5.3 SM-CANopen default data mapping**

Polled channel	Data word	Mapping parameter	Default mapping status
IN channel 0	Word 0, 1	Pr <b>MM.10</b>	1040 (Pr <b>10.40</b> , status word)
IN channel 1	Word 2, 3	Pr <b>MM.11</b>	201 (Pr <b>2.01</b> , post-ramp speed ref)
OUT channel 0	Word 0, 1	Pr <b>MM.20</b>	642 (Pr <b>6.42</b> , control word)
OUT channel 1	Word 2, 3	Pr <b>MM.21</b>	121 (Pr <b>1.21</b> , digital speed ref 1)

**NOTE** For information on setting up more than PDOA (1) please see section 5.6 *Types of set-up* on page 28.

## 5.10 Default COB-IDs and transmission type

SM-CANopen TxPDOA (TxPDO1 by default) transmission type		
Pr <b>MM.41</b>	Default	255
	Range	0 to 255
	Access	RW

TxPDOA transmission type defaults to 255. If Pr **MM.41** is set to 1 and the SM-CANopen is reset, this will cause the SM-CANopen to transmit TxPDOA in response to every SYNC message received. RxPDOA defaults to transmission type 255, meaning that RxPDOA will be processed immediately when it is received. All transmission types are supported, refer to Chapter 12 *CANopen Reference* on page 106 for more details.

Default COB-IDs are assigned to RxPDO1, TxPDO1 and SDO transfers are in accordance with CiA Draft Standard 301 Version 4.1 and are shown in Table 5.4.

**Table 5.4 Default COB-IDs for PDO1 and SDO transfers**

Object	COB-ID (hex.)	COB-ID (dec.)
TxPDO1	0x180 + node address	384 + node address
RxPDO1	0x200 + node address	512 + node address
SDO (tx)	0x580 + node address	1408 + node address
SDO (rx)	0x600 + node address	1536 + node address

**NOTE** This parameter will not be used if SM-CANopen is configured using SDOs. For information on setting up more than PDOA please see section 5.6 *Types of set-up* on page 28. By default PDOA is configured as PDO1 this can be changed using objects 0x2800 and 0x2801.

## 5.11 SM-CANopen operating status

CANopen operating status		
Pr <b>MM.06</b>	Default	N/A
	Range	-10 to 9999
	Access	RO

CANopen network activity can be monitored in the SM-CANopen operating status parameter Pr **MM.06**. When SM-CANopen is communicating successfully with the CANopen master controller, the SM-CANopen operating status will give an approximate indication of the number of data messages per second that are being processed.

**NOTE** In software versions up to and including V03.01.00, Pr **MM.06** includes all received PDOs, SYNC messages and transmitted PDO messages. The network loss trip will occur if no SYNC or RxPDOs are received and no TxPDOs transmitted within the trip time period (Pr **MM.07**). Please refer to section 11.1 *SM-CANopen network loss trip time-out* on page 78 for details on Pr **MM.07**.

In software versions V03.01.01 and later, Pr **MM.06** includes all received PDOs, SYNC messages, and ALL transmitted messages of ANY type. The network loss trip will occur if no SYNC or PDOs are received within the trip time period. ALL transmitted messages will be ignored for the purpose on network loss trip detection.

Table 5.5 shows the possible values displayed in Pr **MM.06**.

**Table 5.5 SM-CANopen operating status codes**

MM.06	Parameter	Description
>0	Network healthy	Indicates the approximate number of successful network cycles per second. This number may vary between different versions of software (see Pr <b>MM.06</b> description for more details).
0	Network healthy, no data transfer	Indicates that the CANopen master has established communications with SM-CANopen, but there is currently no data transfer in progress.
-1	Initialised	Indicates that the SM-CANopen has initialised correctly and is waiting for the CANopen master to initialise communications. This may also indicate a mismatch between the master and the SM-CANopen configuration.
-2	Internal hardware failure	Indicates that part of the SM-CANopen initialisation sequence was not successful. If this fault persists after a power cycle, replace the SM-CANopen.

**Table 5.5 SM-CANopen operating status codes**

MM.06	Parameter	Description
-3	Configuration error	Indicates that there is an invalid setting in the SM-CANopen configuration parameters. See section 10.6 <i>SM-CANopen mapping status</i> on page 73 and 10.7 <i>SM-CANopen error code</i> on page 76 for further diagnostic details.
-4	Unrecoverable software error	An internal software error has occurred. Reset the SM-CANopen to clear, if error persists, replace the SM-CANopen.
-8	Data rate detection in progress	The SM-CANopen is currently attempting to detect the CANopen network data rate.
-10	Device disabled	Indicates that the DS301 V1.1 CANopen communications layer has been disabled by setting the node address to 0.

## 5.12 Resetting the SM-CANopen (re-initialising)

SM-CANopen reset		
Pr MM.32	Default	0 (OFF)
	Range	0 (OFF) to 1 (ON)
	Access	RW

Changes to the SM-CANopen configuration in menu 15 (15, 16 and 17 for Unidrive SP) parameters will not take effect until the SM-CANopen has been reset.

To reset SM-CANopen:

1. Set Pr **MM.32** to ON.
2. When the reset sequence has been completed, Pr **MM.32** will be reset to OFF (the change to 1 may not be visible).
3. The SM-CANopen will re-initialise using the updated configuration.

**NOTE**

This sequence does NOT store SM-CANopen configuration parameters or SDO setup in the drive or the SM-CANopen FLASH memory. See section 5.14 *Storing SM-CANopen configuration parameters* on page 43 for more information.

## 5.13 Unidrive SP: reset Solutions Modules

To reset all Solutions Modules fitted:

1. Set Pr **MM.00** to 1070.

Press the red RESET button on the drive.

**NOTE**

This sequence does NOT store the SM-CANopen configuration parameters or communication settings (SDO set-up) in the drive or the SM-CANopen FLASH memory. See section 5.14 *Storing SM-CANopen configuration parameters* for more information.

## 5.14 Storing SM-CANopen configuration parameters

Menu 15 (menu 15, 16 and 17 on Unidrive SP) parameters are stored in the host drive. The SM-CANopen will always use these values during initialisation to configure itself, so if a new SM-CANopen is fitted to the same slot, it will communicate using the same settings as the previous SM-CANopen (this will not retrieve the communication parameters (SDO configuration), see Chapter 12 *CANopen Reference* on page 106 for more information).

If the stored values in the host drive are for a different type of Solutions Module, the host drive will trip. The slot configuration parameters will be set to default values for SM-CANopen, but the default values will NOT be stored in the host drive.

Information
Safety
Introduction
Mechanical Installation
Electrical Installation
Getting Started
EDS Files
Cyclic Data
Non-Cyclic Data
Control and Status Words
Diagnostics
Advanced Features
CANopen Reference
Quick Reference
Glossary Of Terms
Index

The SM-CANopen configuration parameters can also be stored in the FLASH memory on the SM-CANopen. If the drive is replaced, the SM-CANopen configuration parameters can subsequently be restored to the new drive.

### 5.14.1 Saving parameters on Unidrive SP/Commander SK

This procedure stores the operating parameters for the SM-CANopen to the drive's internal memory. To store parameters in the host drive:

1. Set Pr **MM.00** to 1000 (a Unidrive SP on 24V supply only requires a value of 1001).
2. Press the red RESET button.

The drive will store all parameters, (except Menu 20 unless SM-Applications/ SM-Applications Lite is fitted and configured appropriately) but the operation of the SM-CANopen will not be affected. Changes made to the SM-CANopen configuration parameters will not take effect until the SM-CANopen is reset (Pr **MM.32**).

**NOTE** To save parameters from SM-CANopen to the memory on Commander SX, press M key.

### 5.14.2 Back-up parameters to SM-CANopen FLASH memory

This procedure can be used to transfer settings to a new drive from a previously configured SM-CANopen module. To store the SM-CANopen configuration parameters in the FLASH memory in the SM-CANopen:

1. Set Pr **MM.31** to ON.
2. Set Pr **MM.00** to 1000 (a Unidrive SP on 24V only requires a value of 1001).\*
3. Press the red RESET button.\*

The host drive will store its parameters, and CANopen communication will be halted immediately. The SM-CANopen configuration parameters will be saved within the FLASH memory. The SM-CANopen will then reset and re-initialise using the updated configuration parameter values.

**NOTE** To save parameters from SM-CANopen to the memory on Commander SX, press M key.  
\* Steps 2 and 3 are not required on Commander SX.

## 5.15 Restore SM-CANopen defaults

Restore SM-CANopen defaults		
Pr <b>MM.30</b>	<b>Default</b>	OFF (0)
	<b>Range</b>	OFF (0) or ON (1)
	<b>Access</b>	RW

This procedure can be used to default the CANopen module to factory settings, this will also default the drive settings. If the SM-CANopen detects that the host drive has been restored to default values, it will over-write the slot configuration parameters with the SM-CANopen default values. This will also clear any SDO configuration previously saved with object 0x1010.

**NOTE** If the stored values in the drive are for a different type of Solutions Module, the SM-CANopen will trip "SLx.DF", but no error code will be set. It will over-write the parameter values with the SM-CANopen default values, but will NOT store these values in the drive.

Pr **MM.30** specifies whether the default values should be written to the SM-CANopen FLASH memory when the host drive is defaulted. If Pr **MM.30** is set to ON, the default values will be written into the SM-CANopen FLASH memory.

The full sequence of events to restore default settings for a SM-CANopen is as follows:

1. Set Pr **MM.30** to 1.
2. **Unidrive SP** - Set Pr **MM.00** to 1233 to restore European defaults (1244 for USA defaults). **Commander SK** - Set Pr **00.29** to *EUR* for European defaults (*USA* for American defaults). **Commander SX** - Set Pr **00.65** to *Eur* for European defaults (*USA* for American defaults).
3. Press the red reset button on the drive.
4. CANopen communications will be stopped.
5. The host drive will load and store its default parameter values.
6. Default parameter values for the SM-CANopen will be loaded in Pr **MM.xx** parameters.
7. The SM-CANopen default parameter values will be stored in the SM-CANopen FLASH memory.
8. SM-CANopen will reset and re-initialise using the default values.

**NOTE** The drive settings will also be defaulted with the above procedure.

## 5.16 Restore previous SM-CANopen configuration

Upload from SM-CANopen FLASH memory		
Pr <b>MM.33</b>	<b>Default</b>	OFF (0)
	<b>Range</b>	OFF (0) or ON (1)
	<b>Access</b>	RW

If valid configuration parameters have previously been stored in the SM-CANopen FLASH memory, these values can be restored to the host drive. When the configuration parameter values have been uploaded to the host drive, the SM-CANopen will reset and re-configure itself using the updated parameter values. Object 0x1010 additionally allows the communication object settings sent by a master to be saved.

This feature allows a pre-configured SM-CANopen to be fitted to a host drive without losing the SM-CANopen configuration. If the SM-CANopen is unable to upload the configuration parameters to the host drive, or configuration parameters have never been stored in the SM-CANopen FLASH memory, the host drive will trip and set the error code (Pr **MM.49**) to 70.

When Pr **MM.33** is set to ON, the SM-CANopen will transfer the configuration parameters from its FLASH memory to the host drive, over-writing the existing values in the host drive.

The full sequence of events for restoring values from a SM-CANopen is as follows:

1. Set Pr **MM.33** to ON.
2. CANopen communications will be stopped.
3. The SM-CANopen will overwrite all Pr **MM.xx** parameters with the values stored in its internal FLASH memory.
4. Pr **MM.33** will be reset to OFF.
5. The SM-CANopen will reset and re-initialise using the restored values.

This procedure will NOT store the updated host drive parameters, to do this a drive save must be performed.

**NOTE** The SM-CANopen will restore its configuration parameters to the menu of parameters associated with the slot that it is installed in. If an SM-CANopen is moved from slot 3 on a Unidrive SP, it can be re-installed in any slot on another Unidrive SP using this procedure.

# 6 EDS Files

## 6.1 What are EDS files?

An EDS (Electronic Data Sheet) file is an ASCII text file, which can be opened, edited, and saved in a simple text editor such as Microsoft Notepad. Before altering an EDS file ensure you have saved a copy of the original file. To maintain good backup practice it is recommended that you rename a copy of the file you wish to edit in the following format:

*OriginalName\_YourCompanyName\_RevisionNumber.EDS*

EDS files are used by some CANopen network configuration tools. They contain information about the objects supported by the drive. EDS files are normally only used during network configuration (some CANopen master controllers do not use EDS files at all).

## 6.2 Supplied EDS files

The files listed in Table 6.1 are generic files that will support a drive fitted with SM-CANopen and an SM-Applications (where fitted). SM-CANopen and SM-Applications configuration parameters are accessed as Pr **60.XX** and Pr **81.XX** respectively, as this allows the modules to be fitted in any slot and the EDS file will still work. The EDS files are available directly from your supplier or local drive centre.

**NOTE** Generic EDS files are not strictly conformant to the CANopen EDS file specification, as some drive parameters are not listed. For example, if SM-CANopen is fitted in slot 1 and SM-Applications is fitted in slot 2, the configuration parameters for slot 3 (Pr **17.PP**) cannot be accessed.

**Table 6.1 Generic SM-CANopen EDS files**

Drive	Drive mode	Additional modules	Data compression	DSP402 profiles	EDS filename
Unidrive SP	Open loop	None	OFF	Disabled	USPOL_G.EDS
Unidrive SP	Open loop	SM-Apps	OFF	Disabled	USPOL_GAP.EDS
Unidrive SP	Open loop	None	ON	Disabled	USPOL_G_DC.EDS
Unidrive SP	Open loop	SM-Apps	ON	Disabled	USPOL_GAP_DC.EDS
Unidrive SP	Open loop	None	ON	Enabled	USPOL_G_DCDP.EDS
Unidrive SP	Open loop	SM-Apps	ON	Enabled	USPOL_GAP_DCDP.EDS
Unidrive SP	Closed loop	None	OFF	Disabled	USPCL_G.EDS
Unidrive SP	Closed loop	SM-Apps	OFF	Disabled	USPCL_GAP.EDS
Unidrive SP	Closed loop	None	ON	Disabled	USPCL_G_DC.EDS
Unidrive SP	Closed loop	SM-Apps	ON	Disabled	USPCL_GAP_DC.EDS
Unidrive SP	Closed loop	None	ON	Enabled	USPCL_G_DCDP.EDS
Unidrive SP	Closed loop	SM-Apps	ON	Enabled	USPCL_GAP_DCDP.EDS
Unidrive SP	Servo	None	OFF	Disabled	USPSV_G.EDS
Unidrive SP	Servo	SM-Apps	OFF	Disabled	USPSV_GAP.EDS
Unidrive SP	Servo	None	ON	Disabled	USPSV_G_DC.EDS
Unidrive SP	Servo	SM-Apps	ON	Disabled	USPSV_GAP_DC.EDS

**Table 6.1 Generic SM-CANopen EDS files**

Drive	Drive mode	Additional modules	Data compression	DSP402 profiles	EDS filename
Unidrive SP	Servo	None	ON	Enabled	USPSV_G_DCDP.EDS
Unidrive SP	Servo	SM-Apps	ON	Enabled	USPSV_GAP_DCDP.EDS
Commander SK	Open loop	None	OFF	Disabled	CSK_G.EDS
Commander SK	Open loop	None	ON	Disabled	CSK_G_DC.EDS
Commander SK	Open loop	None	ON	Enabled	CSK_G_DCDP.EDS
Commander SX	Open loop	None	OFF	Disabled	PXOL_G.EDS
Commander SX	Closed loop	None	OFF	Disabled	PXCL_G.EDS

Bitmap files are supplied with the EDS files for use with the CANopen configuration software on the master. Refer to the master configuration software documentation for instructions on how to install EDS files. Control Techniques cannot provide specific technical support for any of these CANopen configuration packages.

### 6.3 Changing EDS files/customisation

Normally it is not necessary to change EDS files however in certain circumstances it may be necessary to do this (in particular with certain combinations of modules on the Unidrive SP).

# 7 Cyclic Data

## 7.1 What is a “Process Data Object”?

Cyclic data is implemented on CANopen networks by using “process data objects” or PDOs. Separate data objects are used for transmitting (TxPDOs) and receiving (RxPDOs) data. PDO configuration objects are usually pre-configured in the CANopen master controller and downloaded to the SM-CANopen at network initialisation using SDOs.

Mapping parameters are provided that can be used to configure RxPDO1 and TxPDO1 in SM-CANopen (or the first configured PDO (A) if this has been changed using objects 0x2800 or 0x2801). These parameters are used to set default values in the PDO mapping objects during initialisation.

**NOTE** Slot parameters (Pr **MM.xx**) are only required for configuration of the first PDO when configuration is done without SDOs. Configuration would normally be done with SDOs, if supported by the master.

**NOTE** If the CANopen master controller over-writes the mapping objects, the mapping parameters are NOT automatically updated to indicate the new mappings, in the corresponding slot menus. TxPDO and RxPDO describe the direction of data transfer as seen by the slave devices on a CANopen network. By default TxPDOA (default TxPDO1) is configured as transmission type 255.

## 7.2 SM-CANopen data format

SM-CANopen data format PDOA (by default PDO1)		
Pr <b>MM.05</b>	Default	4
	Range	0-4, 100-103,300*
	Access	RW

This parameter specifies the number of data words (16 bit) in the RxPDO and TxPDO for the first configured PDO (PDOA which by default is PDO1). Pr **MM.05** is used when configuring a single PDO using the slot parameters (Pr **MM.xx**) only.

To specify different lengths for RxPDOA and TxPDOA Pr **MM.39** and Pr **MM.40** should be used instead, this however, is not normally required.

SM-CANopen can be configured with up to 4 data words (16 bit) on TxPDOA and 4 data words (16 bit) on RxPDOA. These data words may be configured using mapping parameters (Pr **MM.xx**) for PDOA only, or alternatively all PDOs (A,B,C & D) may be configured using SDOs from the master. See Chapter 5.3 *Flexible PDO Numbering (software compatibility)* on page 27 for more information on PDO numbering.

A value of 100-103 indicates that the first cyclic channel is used for CT mode 1 (non-cyclic) communications. Chapter 8.2 *Mode 1 - CT Single Word mode* on page 56 gives more information on configuring CT mode 1 non-cyclic data.

**NOTE** \*For SM-CANopen firmware 03.01.01 and above, any modifications to the standard configuration for PDOA performed over the SDO protocol will result in the mode parameter (Pr **MM.05**) being set to 300.

## 7.3 Data size on the network

Depending upon the size of the source/destination parameter, the size of the data on the network (PDO or SDO) will vary according to the state of Pr **MM.34** (data compression). When data compression is enabled (by setting Pr **MM.34** = ON) a mapping will use 32 bits if the target drive parameter is a 32 bit parameter. If the target drive parameter for a mapping is only 1, 8 or 16 bits, only 16 bits will be used for that particular mapping (see section 11.8 *Cyclic data compression* on page 84 for more information). This effectively enables 4 mappings per PDO with compression on and 16 bit (or less) mappings as opposed to 2 with compression off or 32 bit mappings (see Figure 7-1 for more details).

**Figure 7-1 Data compression - parameters / network data size**

Source/Destination Parameter Size	Size of Data on Network	
	MM.34 = 1(off)	MM.34 = 1(on)
32 bit *	32 bit *	32 bit *
16 bit	32 bit	16 bit
8 bit	32 bit	16 bit
1 bit	32 bit	16 bit

\* 32 bit parameters do not compress  
16 bit parameters (or less) compress to 16 bit

## 7.4 Default settings

The following details only apply to a PDO configured using parameters in SM-CANopen (Pr **MM.xx**). The setup flowcharts in Chapter 5.6 *Types of set-up* on page 28 detail the setup procedure if the PDO is configured using SDOs.

The SM-CANopen data format for RxPDOA and TxPDOA (which is by default PDO1) is specified as "NPP", where N is the non-cyclic data mode, and PP is the number of data words.

**Table 7.1 Valid SM-CANopen data formats**

Pr <b>MM.05</b>	N	PP	Non-cyclic mode	Cyclic words
0	0	0	Refer to section 11.10 <i>PDOA length</i> on page 85 or section 12.15.1 <i>Enable DSP402 device profiles</i> on page 137	
1 to 4	0	1 to 4	SDO only	1 to 4
100 to 103	1	0 to 3	SDO plus CT Single Word	0 to 3
300	<i>Indicates that the configuration is provided from the master</i>			

The reference for the source or target parameter is entered in the mapping parameter in the form MMPP, where MM = menu number of the target/source parameter and PP = parameter number of the target/source parameter.

**Table 7.2 SM-CANopen PDO default mapping parameters**

IN channel TxPDOA	Mapping parameter	OUT channel RxPDOA	Mapping parameter
	Slot		Slot
0	Pr MM.10	0	Pr MM.20
1	Pr MM.11	1	Pr MM.21
2	Pr MM.12	2	Pr MM.22
3	Pr MM.13	3	Pr MM.23

If a mapping parameter is set to an invalid value (e.g. destination parameter is read only, or parameter does not exist) SM-CANopen will indicate “-3” in the operating status parameter (Pr MM.06). The reason for the mapping error will be indicated by the mapping status parameter (Pr MM.49), refer to section 10.6 *SM-CANopen mapping status* on page 73 for more details.

**NOTE** The IN channel referred to in Table 7.2 is from the perspective of the PLC i.e. referencing data flowing into the PLC.

When the data format is configured using Pr MM.05, SM-CANopen will communicate using the same number of data words for RxPDOA and TxPDOA. It is, however, possible to configure SM-CANopen to communicate with different numbers of words for TxPDOA and RxPDOA. Refer to section 11.10 *PDOA length* on page 85 for full details.

The following sections show some example data formats that can be selected and the parameter mapping that will apply (by default) to each format.

#### 7.4.1 PDOA 2 channels (default) - standard mappings

**NOTE** PDO data channels do not use decimal points. For example, in open loop mode, the Unidrive SP digital speed reference 1 (Pr 1.21) has units of Hertz, accurate to 1 decimal place. To write a value of 24.6Hz to Pr 1.21, the value must be transmitted as 246.

This data format provides 2 data channels on TxPDOA (by default TxPDO1) and RxPDOA (by default RxPDO1) with no non-cyclic data channel. The total data length is 4 words or 8 bytes. To select this data format, set Pr MM.05 = 4. This data format is selected by default.

**Table 7.3 Mapping for PDO1 - 2 channels in and out**

Data word	Parameter	Default mapping status
IN word 0, 1, (TxPDO)	Pr MM.10	Pr 10.40, status word
IN word 2, 3 (TxPDO)	Pr MM.11	Pr 2.01, post-ramp speed reference
OUT word 0, 1 (RxPDO)	Pr MM.20	Pr 6.42, control word
OUT word 2, 3 (RxPDO)	Pr MM.21	Pr 1.21, digital speed reference 1

## 7.4.2 PDOA with 1 channel and CT Single Word non-cyclic data

This data format provides 1 data channel with CT Single Word (Mode 1) non-cyclic data, (see section 8.2 *Mode 1 - CT Single Word mode* on page 56). The data length is 2 words plus 2 words for non-cyclic data (i.e. a total of 4 words). To select this data format, set Pr **MM.05** = 101.

**Table 7.4 Mapping for 1 PDO channel with CT Single Word non-cyclic data**

Data word	Parameter	Default mapping status
IN word 0, 1 (TxPDO)	Pr <b>MM.10</b>	Pr <b>61.50</b> , CT Mode 1 non-cyclic data
IN word 2, 3 (TxPDO)	Pr <b>MM.11</b>	Pr <b>10.40</b> , status word
OUT word 0, 1 (RxPDO)	Pr <b>MM.20</b>	Pr <b>61.50</b> , CT Mode 1 non-cyclic data
OUT word 2, 3 (RxPDO)	Pr <b>MM.21</b>	Pr <b>6.42</b> , control word

## 7.4.3 Additional PDOs and device profiles

The SM-CANopen supports a total of 4 PDOs, plus 3 device profiles. For further information, refer to Chapter 12 *CANopen Reference* on page 106.

## 7.4.4 Duplicate mapping

Care must be taken to ensure that there are no conflicts between the mapping of cyclic data, and the analog and digital inputs within the drive itself. SM-CANopen will not indicate if there is a conflict with drive mapping parameters.

If a parameter is written to from two different sources, the value of this parameter will depend entirely upon the scan time for the parameter and the CANopen network cycle. This may cause the value in the parameter to change continuously between 2 values.

## 7.5 PDO data mapping errors

The SM-CANopen will scan and check the mapping parameter configuration for errors. If an error is detected, the operating status parameter will indicate “-3” and the mapping status will be indicated in Pr **MM.49**, see section 10.6 *SM-CANopen mapping status* on page 73 for full details.

## 7.6 Unused PDO data channels

If any data words are not being used in an application, the un-used mapping parameters should be set to 0. Although the data word will still be transmitted over the CANopen network, any incoming data will be discarded by SM-CANopen and unmapped data words being passed back to the CANopen master controller will be set to 0.

### NOTE

Remember all parameters will have to be stored after they are set. See section 5.14 *Storing SM-CANopen configuration parameters* on page 43.

## 7.7 Changing PDO mapping parameters

When a PDO is enabled, SM-CANopen uses the PDO mapping parameters to calculate the total number of data bytes that will make up the PDO. For a TxPDO, this defines the total number of bytes that will be transmitted. For an RxPDO, this defines how many bytes will be processed; any additional bytes received will be discarded.

The mapping parameters for a PDO can only be modified when the number of mapped application objects in PDO (sub-index 0) is set to 0. This effectively disables the PDO while the mapping is modified using SDO communications. Once all mapping

parameters have been updated, the PDO sub-index 0 is set to specify the total number of defined mappings (normally 4 or 2). SM-CANopen will calculate the PDO length from the mappings, and activate the changes to the PDO mappings.

## 7.8 Blank mapping parameters

If multiple SM-CANopen nodes are configured with the same COB-ID for an RxPDO, they will all receive the RxPDO at the same time. For example, in a system of 4 drives, RxPDO1 could be used to transmit a 16-bit speed reference to each node.

However, the RxPDO1 mapping in each node must be configured to use only one word received on RxPDO1, and discard all other words. This can be achieved by creating a “blank mapping”. For an RxPDO, data with a blank mapping will simply be discarded. TxPDO data values with a blank mapping will be set to 0.

**Table 7.5 Blank mapping objects**

Index	Object code	Name	Type	Access	PDO mapping
0x0002	DEFTYPE	<b>INTEGER8</b>	INTEGER8	RW	Yes
0x0003	DEFTYPE	<b>INTEGER16</b>	INTEGER16	RW	Yes
0x0004	DEFTYPE	<b>INTEGER32</b>	INTEGER32	RW	Yes
0x0005	DEFTYPE	<b>UNSIGNED8</b>	UNSIGNED8	RW	Yes
0x0006	DEFTYPE	<b>UNSIGNED16</b>	UNSIGNED16	RW	Yes
0x0007	DEFTYPE	<b>UNSIGNED32</b>	UNSIGNED32	RW	Yes

Unwanted data should be mapped to the DEFTYPE object of appropriate size. Bytes, words and double words are supported, but the BOOLEAN TYPE IS NOT SUPPORTED. The only other limitation is that there are only 4 mapping parameters per PDO, due to memory restrictions.

For example, consider RxPDOA (by default PDO1) containing four 16-bit speed references, one each for 4 different nodes. If a node needs to access only the 3rd word of RxPDOA and map it to Pr **18.11**, while ignoring the remaining words, the mapping configuration required is shown in Table 7.6.

**Table 7.6 Example of blank mapping objects**

Word	Object	Value
0	0x1600sub1	0x00030010
1	0x1600sub2	0x00030010
2	0x1600sub3	0x20120B10
3	0x1600sub4	0x00030010

**NOTE** Blank mapping objects allow the mappings to contain null references that are not possible by other means.

---

## 8 Non-Cyclic Data

---

SM-CANopen provides two different methods to implement non-cyclic data. The “Service Data Object” or SDO provides the non-cyclic data channel on a CANopen system and allows access to all objects in the SM-CANopen object dictionary. Object access using SDO is controlled entirely by the master controller program.

CT Mode 1 (single word) non-cyclic data is also available on SM-CANopen. This method uses a single word of the TxPDO and RxPDO, to implement the CT Single Word protocol, allowing access to any drive parameter (see section 8.2 *Mode 1 - CT Single Word mode* on page 56 for more information).

**Table 8.1 SM-CANopen non-cyclic data modes**

Non-cyclic mode	Format	Pr MM.05	Non-cyclic access
Disabled	None	0PP	SDO only
Mode 1	CT Single Word	1PP	SDO plus CT Single Word

Non-cyclic data transfer is implemented entirely in the CANopen master, for this reason, Control Techniques is unable to offer any specific technical support with implementing non-cyclic data transfer for any particular CANopen master.

**NOTE** The non-cyclic data channel does not use decimal points. For example, in open loop mode, digital speed reference 1 (Pr **1.21**) has units of Hertz, accurate to 1 decimal place. To write a value of 24.6Hz to Pr **1.21**, the value must be transmitted as 246.

### 8.1 Service data object (SDO) parameter access

The service data object (SDO) provides access to all objects in the CANopen object dictionary and the drive parameters are mapped into the object dictionary as 0x2XXX objects in the following way:

Index:                   0x2000 + *menu*  
Sub-index:              *parameter*

For example Pr **20.21** would be index *0x2014* and the sub-index would be *0x15*. The values are usually expressed in base 16, so care must be taken to enter the correct parameter number.

All other supported entries in the SM-CANopen object dictionary can also be accessed using SDOs. See Chapter 12 *CANopen Reference* on page 106 for a full list of supported objects. Refer to the master controller documentation for full details about implementing SDO transfers within the particular master controller.

**NOTE** Sub-index 0 for any menu will return the highest sub-index available for the object (i.e. the highest parameter number). Pr **xx.00** in any drive can only be accessed as Pr **61. 01**. Commander SX does not support this functionality.

When accessing drive parameters using an SDO, all parameters must be treated as signed 32-bit parameters. If the target parameter is a 16-bit parameter, the data value will be cast to a 32-bit integer. The sign of the 16-bit value will be preserved.

The following SDO services are supported:

- Initiate SDO Download (*Write*)
- Initiate SDO Upload (*Read*)
- Abort SDO Transfer (*Error*)

### 8.1.1 SDO abort codes (errors)

SDO messages use a request-response mechanism and the CANopen master will always expect a response from the slave device. If an error occurs with an SDO transfer SM-CANopen will return an SDO abort code to indicate the reason for the failure, the SDO abort codes are listed in Table 8.2.

**Table 8.2 SDO abort codes**

Abort code (in hex.)	Description
0x05030000	Toggle bit not alternated.
0x05040000	SDO protocol timed out.
0x05040001	Client/server command specifier not valid or unknown.
0x05040002	Invalid block size (block mode only).
0x05040003	Invalid sequence number (block mode only).
0x05040004	CRC error (block mode only).
0x05040005	Out of memory.
0x06010000	Unsupported access to an object.
0x06010001	Attempt to read a write only object.
0x06010002	Attempt to write a read only object.
0x06020000	Object does not exist in the object dictionary.
0x06040041	Object cannot be mapped to the PDO.
0x06040042	The number and length of the objects to be mapped would exceed PDO length.
0x06040043	General parameter incompatibility.
0x06040047	General internal incompatibility in the device.
0x06060000	Access failed due to a hardware error.
0x06070010	Data type does not match, length of service parameter does not match.
0x06070012	Data type does not match, length of service parameter too high.
0x06070013	Data type does not match, length of service parameter too low.
0x06090011	Sub-index does not exist.
0x06090030	Value range of parameter exceeded (only for write access).
0x06090031	Value of parameter written too high.
0x06090032	Value of parameter written too low.
0x06090036	Maximum value is less than minimum value.
0x08000000	General error.
0x08000020	Data cannot be transferred or stored to the application.
0x08000021	Data cannot be transferred or stored to the application because of local control.
0x08000022	Data cannot be transferred or stored to the application because of the present device state.
0x08000023	Object dictionary dynamic generation fails or no object dictionary is present.

Safety Information
Introduction
Mechanical Installation
Electrical Installation
Getting Started
EPS Files
Cyclic Data
<b>Non-Cyclic Data</b>
Control and Status Words
Diagnostics
Advanced Features
CANopen Reference
Quick Reference
Glossary Of Terms
Index

## 8.2 Mode 1 - CT Single Word mode

The CT Single Word (Mode 1) uses one cyclic channel for non-cyclic data. The non-cyclic sub-protocol for the drive requires a specific sequence of 4 or 6 telegrams to implement the parameter access. Each non-cyclic word or telegram is split into 2 bytes to implement the sub-protocol, with the high byte containing the control codes for each telegram, and the low byte containing the data for each telegram.

**NOTE** If cyclic data compression is disabled, the CT Single Word non-cyclic channel will be 32-bits wide, i.e. uses 2 words, and data must be transferred on the low word. If cyclic data compression is enabled, the CT Single Word non-cyclic channel will revert to 16-bits and only use 1 word.

### 8.2.1 Mapping for CT Single Word non-cyclic data (using Pr MM.xx)

To configure an SM-CANopen for CT Single Word Mode non-cyclic data, the following steps must be performed:

1. Set Pr **MM.05** to the required mode.
2. Set Pr **MM.32** to ON to reset and re-initialise SM-CANopen.

When SM-CANopen re-initialises it will map cyclic data IN Word 0 and OUT Word 0 to the CT Single Word protocol parameter Pr **61.50**. All existing mapping parameters will be moved down by 1 word, i.e. the previous mapping set in Pr **MM.10** and Pr **MM.20** will now appear in Pr **MM.11** and Pr **MM.21**. Parameter Pr **61.50** may be mapped using either SDOs from the master or the slot menu (Pr **MM.xx**).

**NOTE** If all IN (TxPDO) or OUT (RxPDO) mapping parameters are being used when the data format change is implemented, the last mapping parameter value will be lost.

**NOTE** It is possible to map the non cyclic channel (Mode 1) using SDOs to the appropriate mapping object. A mapping is required for both the IN (TxPDO) and OUT (RxPDO) word and may be contained in any PDO.

### 8.2.2 CT Single Word protocol

All parameter values for the drive must be written as signed 32-bit data values. Decimal point information is inserted automatically when the data value is written to the drive, and removed when the data value is read. It is important that the number of decimal places of the target parameter is known to prevent scaling errors.

For example writing a value of 1234 to a parameter with 2 decimal places will produce a value of 12.34 in the target parameter, reading a value of 12.34 will return a 32-bit integer value of 1234.

Table 8.3 shows the bit allocations for CT Single word protocol.

**Table 8.3 CT Single Word bit allocation**

b15	b14	b13	b12	b11	b10	b9	b8
READ	ERR	Reserved	32-BIT	Stamp Number			
b7	b6	b5	b4	b3	b2	b1	b0
Data Byte							

**Table 8.4 CT Single Word format**

Bit	Function	Values	Description
0 to 7	Data	0 to 255	Depending on the stamp number of the telegram, this byte contains the menu, parameter or data byte.
8 to 11	Stamp number	0 to 6	Indicates the stamp number of the word. This shows which part of the message is currently in progress. Setting the stamp number to 0 resets the internal non-cyclic state machine.
12	32-BIT	0 = 16-bit data 1 = 32-bit data	Specifies whether a 16-bit or 32-bit data value is to be written to or read from the drive. If 32-BIT is set, telegrams 5 and 6 will be used to transfer the additional data bytes.
13	Reserved	0	Reserved for future use. Always set to 0.
14	ERR	0 = Data OK 1 = Error	Indicates the success or failure of the message. Failure could occur if the parameter does not exist, or is a read-only/write-only parameter. This bit will also be set if the parameter value is out of range in 16-bit mode.
15	READ	0 = Write 1 = Read	Defines whether the data word is part of a READ or WRITE cycle.

**8.2.3 16-bit parameter access**

16-bit data can be used to access parameters within the drive using only 4 telegrams. If an attempt is made to read a 32-bit parameter from the drive, the parameter value will be returned, provided that the parameter value does not exceed a signed 16-bit limits. If the value is larger than a signed 16-bit value, the ERR bit will be set. When writing data to a 32-bit parameter, the 16-bit data will be treated as a signed 16-bit data value. This limits the range that can be written to a 32-bit parameter.

Safety Information
Introduction
Mechanical Installation
Electrical Installation
Getting Started
EDS Files
Cyclic Data
<b>Non-Cyclic Data</b>
Control and Status Words
Diagnostics
Advanced Features
CANopen Reference
Quick Reference
Glossary Of Terms
Index

## 8.2.4 Reading parameters using CT Single Word

To read 32-bit parameters using the non-cyclic channel, the following “telegrams” must be transmitted to construct the message.

- Telegram 1 “Define menu number”.
- Telegram 2 “Define parameter number”.
- Telegram 3 “Request high data byte”.
- Telegram 4 “Request mid-high data byte”.
- Telegram 5 “Request mid-low data byte”.
- Telegram 6 “Request low data byte”.

**Figure 8-1 CT Single Word read sequence**

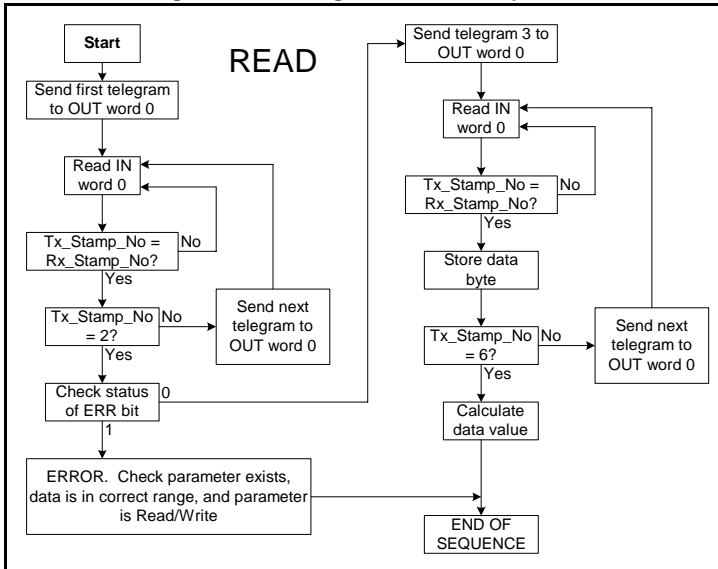

The following example telegrams show how to read the post-ramp speed reference (in rpm with 2 decimal places) from Pr **2.01** in the drive.

### TELEGRAM 1

The first telegram from the CANopen master indicates a READ cycle, and the stamp number is 1. The data byte would contain the menu number for the parameter that is to be read.

Bit	b15-b12	b11-b8	b7-b4	b3-b0
Value	1001	0001	0000	0010

*Data word = 0x9102*

*Stamp number = 1*

*Menu = 2*

When the first telegram has been received and processed in the slave node, it is mirrored in the non-cyclic IN word back to the PLC. This is the signal to the master controller program that the first telegram of the message has been received and the second telegram can be transmitted.

## TELEGRAM 2

The second telegram from the CANopen master also indicates a READ cycle, but the stamp number is now 2. The data byte contains the parameter number for the parameter that is to be read.

Bit	b15-b12	b11-b8	b7-b4	b3-b0
Value	1001	0010	0000	0001

*Data word = 0x9201*

*Stamp number = 2*

*Parameter = 1*

When the second telegram has been received and processed in the slave, it is mirrored in the non-cyclic IN word. This is the signal to the master controller program that the second telegram of the message has been received, and the third telegram can be transmitted.

If telegrams 1 and 2 were not received correctly, or an invalid parameter was specified, SM-CANopen will set the ERROR bit to 1 (b14 = 1) in the data returned to the master and the returned data bits will have no significance. If an error is reported, the non-cyclic data word must be set to 0 to ensure that the non-cyclic state machine is completely reset and ready for the next non-cyclic READ or WRITE sequence.

## TELEGRAM 3

The third telegram from the CANopen master acts as the indication to the slave to send the high data byte from the requested parameter. The data byte is not used in this telegram, and should be set to 0.

Bit	b15-b12	b11-b8	b7-b4	b3-b0
Value	1001	0011	0000	0000

*Data word = 0x9300*

*Stamp number = 3*

When the third telegram has been received and processed in the slave node, the node will mirror the stamp number in the non-cyclic IN word, and load the high byte of the parameter value into the data byte.

Bit	b15-b12	b11-b8	b7-b4	b3-b0
Value	1001	0011	0000	0000

*Data word = 0x9300*

*Stamp number = 3*

*Data high byte = 0x00 = 0*

Safety Information
Introduction
Mechanical Installation
Electrical Installation
Getting Started
EFS Files
Cyclic Data
<b>Non-Cyclic Data</b>
Control and Status Words
Diagnostics
Advanced Features
CANopen Reference
Quick Reference
Glossary Of Terms
Index

## TELEGRAM 4

The fourth telegram from the CANopen master acts as the indication to the slave to send the mid-high data byte from the requested parameter. The data byte is not used in this telegram and should be set to 0.

Bit	b15-b12	b11-b8	b7-b4	b3-b0
Value	1001	0100	0000	0000

*Data word = 0x9400*

*Stamp number = 4*

When the fourth telegram has been received and processed in the slave node, the node will mirror the stamp number in the non-cyclic IN word, and load the mid high byte of the parameter value into the data byte.

Bit	b15-b12	b11-b8	b7-b4	b3-b0
Value	1001	0100	0000	0001

*Data word = 0x9401*

*Stamp number = 4*

*Data mid high byte = 0x01 = 1*

## TELEGRAM 5

The fifth telegram from the CANopen master acts as the indication to the slave to send the mid-low data byte from the requested parameter. The data byte is not used in this telegram and should be set to 0.

Bit	b15-b12	b11-b8	b7-b4	b3-b0
Value	1001	0101	0000	0000

*Data word = 0x9500*

*Stamp number = 5*

When the fifth telegram has been received and processed in the slave node, the node will mirror the stamp number in the non-cyclic IN word, and load the mid-low byte of the parameter value into the data byte.

Bit	b15-b12	b11-b8	b7-b4	b3-b0
Value	1001	0101	0010	0101

*Data word = 0x9505*

*Stamp number = 5*

*Data mid low byte = 0x25 = 37*

## TELEGRAM 6

The sixth telegram from the CANopen master acts as the indication to the slave to send the low data byte from the requested parameter. The data byte is not used in this telegram and should be set to 0.

Bit	b15-b12	b11-b8	b7-b4	b3-b0
Value	1001	0110	0000	0000

*Data word = 0x9600*

*Stamp number = 6*

When the sixth telegram has been received and processed in the slave node, the node will mirror the stamp number in the non-cyclic IN word, and load the low byte of the parameter value into the data byte.

Bit	b15-b12	b11-b8	b7-b4	b3-b0
Value	1001	0110	1101	1100

*Data word = 0x96DC*

*Stamp number = 6*

*Data low byte = 0xDC = 220*

The final value can now be reconstructed as follows:

$$\begin{aligned}\text{Speed} &= (\text{High byte} * 2^{24}) + (\text{Mid-high byte} * 2^{16}) + (\text{Mid-low byte} * 2^8) + \text{Low byte} \\ &= (0 * 16777216) + (1 * 65536) + (37 * 256) + 220 \\ &= 75228 \\ &= 7522.8 \text{ rpm}\end{aligned}$$

## 8.2.5 Writing parameters using CT Single Word

To write to a 32-bit parameter using the non-cyclic channel, the following telegrams must be sent on each network cycle to construct the final message.

- Telegram 1 “Define menu number”.
- Telegram 2 “Define parameter number”.
- Telegram 3 “Send high data byte”.
- Telegram 4 “Send mid-high data byte”.
- Telegram 5 “Send mid-low data byte”.
- Telegram 6 “Send low data byte”.

**Figure 8-2 CT Single Word write sequence**

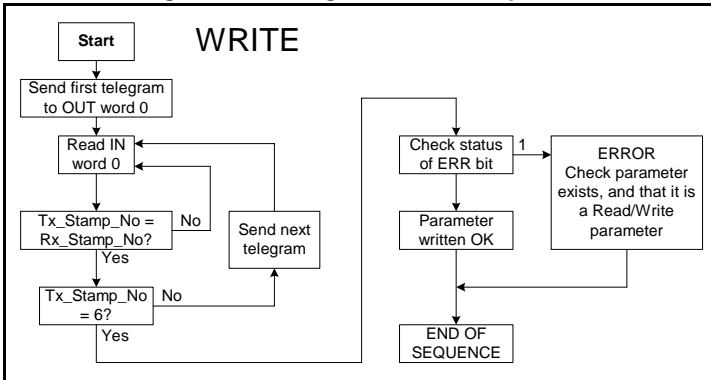

The following example telegrams show how to set the digital speed reference 1 (Pr 1.21) to 12553.9 rpm (32-bit value is 125539) in the drive.

### TELEGRAM 1

The first telegram from the CANopen master indicates a WRITE cycle by setting the Read/Write bit to 0 and the stamp number to 1. The data byte contains the menu number for the parameter that is to be written to.

Bit	b15-b12	b11-b8	b7-b4	b3-b0
Value	0001	0001	0000	0001

*Data word = 0x1101*

*Stamp number = 1*

*Menu = 1*

When the first telegram has been received and processed in the slave node, it is mirrored in the non-cyclic IN word. This is the signal to the master controller program that the first telegram of the message has been received and the second telegram can be transmitted.

## TELEGRAM 2

The second telegram from the CANopen master also indicates a write cycle, but the stamp number is now set to 2. The data byte contains the parameter number for the parameter that is to be written to.

Bit	b15-b12	b11-b8	b7-b4	b3-b0
Value	0001	0010	0001	0101

*Data word = 0x1215*

*Stamp number = 2*

*Parameter = 21*

When the second telegram has been received and processed in the slave node, it is mirrored in the non-cyclic IN word. This is the signal to the master controller program that the second telegram of the message has been received and the third telegram can be transmitted.

## TELEGRAM 3

The third telegram from the CANopen master has the stamp number set to 3. The data bits contain the high data byte for the parameter being written to.

Bit	b15-b12	b11-b8	b7-b4	b3-b0
Value	0001	0011	0000	0000

*Data word = 0x1300*

*Stamp number = 3*

*Data high byte = 0x00*

When the third telegram has been received and processed in the slave node, it is mirrored in the non-cyclic IN word. This is the signal to the master controller program that the third telegram of the message has been received and the fourth telegram can be transmitted.

## TELEGRAM 4

The fourth telegram from the CANopen master has the stamp number set to 4. The data bits contain the mid-high data byte for the parameter being written to.

Bit	b15-b12	b11-b8	b7-b4	b3-b0
Value	0001	0100	0000	0001

*Data word = 0x1401*

*Stamp number = 4*

*Data mid-high byte = 0x01 = 1*

When the fourth telegram has been received and processed in the slave node, it is mirrored in the non-cyclic IN word. This is the signal to the master controller program that the fourth telegram of the message has been received and the fifth telegram can be transmitted.

## TELEGRAM 5

The fifth telegram from the CANopen master has the stamp number set to 5. The data bits contain the mid-low data byte for the parameter being written to.

Bit	b15-b12	b11-b8	b7-b4	b3-b0
Value	0001	0101	1110	1010

*Data word = 0x15EA*

*Stamp number = 5*

*Data mid-low byte = 0xEA = 234*

When the fifth telegram has been received and processed in the slave node, it is mirrored in the non-cyclic IN word. This is the signal to the master controller program that the fifth telegram of the message has been received and the sixth telegram can be transmitted.

## TELEGRAM 6

The sixth telegram from the CANopen master has the stamp number set to 6. The data bits contain the low data byte for the parameter that is being written to.

Bit	b15-b12	b11-b8	b7-b4	b3-b0
Value	0001	0110	0110	0011

*Data word = 0x1663*

*Stamp number = 6*

*Data low byte = 0x63 = 99*

When the sixth telegram has been received and processed in the slave node, it will write the data (Pr 1.21 = 12553.9) as transmitted (the decimal point is automatically inserted when the data is transferred to the drive). If the operation is successful, the ERR bit is reset to 0 and the telegram is reflected in the non-cyclic IN word.

Bit	b15-b12	b11-b8	b7-b4	b3-b0
Value	0001	0110	0110	0011

*Data word = 0x1663*

*Stamp number = 6*

*Data low byte = 0x63 = 99*

If there was a problem with writing the data to the defined parameter, e.g. parameter is read only, does not exist, or data is out of range, the ERR bit is set to 1.

### 8.2.6 Abort CT Single Word non-cyclic message

The internal state machine that controls the non-cyclic data transfer will only accept a new telegram if it contains the next expected telegram number (i.e. after accepting telegram 2, the state machine will only respond to telegram 3). If an error occurs in the master controller that causes the telegrams to get out of step, the master controller program must timeout, abort the message and reset the non-cyclic state machine. A Mode 1 non-cyclic message can be abandoned by resetting the state machine. This is done by setting the non-cyclic word to 0.

Bit	b15-b12	b11-b8	b7-b4	b3-b0
Value	0000	0000	0000	0000

*Data word = 0x0000*

*Stamp number = 0*

### 8.3 SM-CANopen set-up using non-cyclic data

The SM-CANopen can also be configured using SDO or CT Single Word non-cyclic data. The configuration parameters for the slot in which the SM-CANopen is located can be accessed as Pr **60.xx**.

Changes made to the configuration parameters will not take effect until the SM-CANopen has been reset. The SM-CANopen can be reset by writing a value of 1 to Pr **60.32**. A brief interruption in CANopen communications may be seen while the reset sequence is in progress. For information regarding data compression see section 11.8 *Cyclic data compression* on page 84.

**NOTE** All parameters must be stored after they are set, see section 5.14 *Storing SM-CANopen configuration parameters* on page 43 for more information.

---

## 9 Control and Status Words

---

### 9.1 What are control and status words?

The control and status words allow the digital control and monitoring of the drive to be implemented using a single data word for each function. Each bit in the control word has a particular function and provides a method of controlling the output functions of the drive, such as run and direction. These words can be accessed using either cyclic or non cyclic data.

Each bit in the status word provides feedback about the drives state of health and operational condition, such as drive healthy, drive at speed, etc.

### 9.2 Control word

The SM-CANopen control word consists of 16 control bits some of which are reserved. See Table 9.1 for the individual bit function descriptions.

**Table 9.1 Control word bit definitions**

b15	b14*	b13	b12*	b11	b10	b9*	b8
	KEYPAD WDOG	RESET	TRIP			JOG REV	REMOTE
b7*	b6*	b5	b4	b3	b2	b1	b0
AUTO	NOT STOP	RUN	FWD REV	RUN REV	JOG FWD	RUN FWD	ENABLE

\*not used on Commander SX

To enable fieldbus control the fieldbus enable signal (Pr **6.43**) and the auto bit (bit7) must both be set to '1'. When the AUTO bit is reset to 0 the drive will revert to terminal control.

**NOTE** See the Commander SX documentation for a description of these features with Commander SX as these may differ to Unidrive SP and Commander SK.

For safety reasons, the external HARDWARE ENABLE signal must be present before the fieldbus control word can be used to start the drive. This terminal is normally controlled by an external "Emergency Stop" circuit to ensure that the drive is disabled in an emergency situation.

The control word REMOTE bit directly controls the drive parameter Pr **1.42**, the function of which is to select the digital speed reference as the source of the drives speed reference. When the REMOTE bit is reset to 0 the drive will revert to using the external analog speed reference.

The actual digital speed reference selected when REMOTE is set to 1 will be Pr **1.21**, which is also the default mapping for the fieldbus speed reference. However Pr **1.15** can be used to change which of the digital references is selected. For further details on the drive digital speed references, please refer to the appropriate drive *User Guide*.

Table 9.2 lists in detail the function of each control word bit. For further in-depth details about drive control words and sequencing bits please refer to the appropriate drive *User and Advanced User Guides*.

**NOTE** When a trip occurs, the drive control word **MUST** be set to a safe, disabled state. This ensures that the drive does not re-start unexpectedly when it is reset. This can be achieved by continuously monitoring the drive status word and interlocking it with the control word.

**NOTE** By default data compression is off and therefore the control word will be cast as 32 bit with bits 16-31 reserved.

**Table 9.2 Control word bit functions**

Bit	Function	Description
0	ENABLE	Set to 1 to enable the drive. Resetting to 0 will immediately disable the drive, and the motor will <b>coast</b> to a stop. The external HARDWARE ENABLE signal must also be present before the drive can be enabled.
1	RUN FWD	Set to 1 (with ENABLE set to 1) to run the motor in the forward direction. When reset to 0, the drive will <b>decelerate</b> the motor to a controlled stop.
2*	JOG FWD	Set to 1 to jog the motor forward. This signal needs to be used in conjunction with the ENABLE bit. This signal is overridden by a RUN, RUN REV or RUN FWD signal.
3	RUN REV	Set to 1 (with ENABLE set to 1) to run the motor in the reverse direction. When reset to 0, the drive will <b>decelerate</b> the motor to a controlled stop.
4	FWD REV	Set to 1 to select the reverse direction. Set to 0 to run in the forward direction. The RUN signal is used to start and stop the motor.
5	RUN	Set to 1 to run the motor. FWD REV is used to select the direction of motor rotation. When reset to 0, the drive will <b>decelerate</b> the motor to a controlled stop.
6*	NOT STOP	Set to 1 to allow the sequencing bit in the drive to be latched. Refer to the drive <i>Advanced User Guide</i> for more details. If NOT STOP is zero, all latches are cleared and held at 0. Pr <b>6.04</b> must be correctly set for this to function.
7	AUTO	Set to 1 to enable fieldbus control of the drive Control Word. The Control Word Enable (Pr <b>6.43</b> ) must also be set to 1. When reset to 0, the drive will operate under terminal control.
8	REMOTE	Set to 1 to select digital speed reference 1 (Pr <b>1.21</b> ), and to 0 to select analog reference 1 (Pr <b>1.36</b> ). REMOTE directly controls Pr <b>1.42</b> , so reference selector (Pr <b>1.14</b> ) and preset selector (Pr <b>1.15</b> ) must both be set to 0 (default) for the REMOTE bit to work properly.
9*	JOG REV	Set to 1 to jog the motor in reverse. This signal needs to be used in conjunction with the ENABLE bit. This signal is overridden by a RUN/RUN REV/RUN FWD command.
10	Reserved	-
11	Reserved	-
12	TRIP	Set to 1 to trip the drive at any time. The trip display on drive will be "CL.bit" and the trip code will be 35. AUTO (b7) has no effect on this function. The trip cannot be cleared until TRIP is reset to 0.

**Table 9.2 Control word bit functions**

Bit	Function	Description
13	RESET	A 0-1 transition of the RESET bit will reset the drive from a trip condition. If the reason for the trip is still present, or another fault condition has been detected, the drive will immediately trip again. When resetting the drive, it is recommended to check the status word to ensure that the reset was successful, before attempting to re-start the drive.
14*	KEYPAD WDOG	This watchdog is provided for an external keypad or other devices where a break in the communication link must be detected. The watchdog system can be enabled and/or serviced if this bit is changed from zero to one whilst the control word enabled. Once the watchdog is enabled it must be serviced at least once every second or an "SCL" trip will occur. The watchdog is disabled when an "SLC" trip occurs, and so it must be re-enabled when the trip is reset.
15	Reserved	

\*Unidrive SP only.

### 9.3 Status word

The SM-CANopen status word consists of 16 control bits some of which are reserved. See the table below for the individual bit function descriptions.

b15	b14	b13	b12	b11	b10	b9	b8
Not Used	Mains Loss	Direction Running	Direction Set	Brake Alarm	Brake Active	Regen	Current Limit

b7	b6	b5	b4	b3	b2	b1	b0
Load Reached	Above Set Speed	At Set Speed	Below Set Speed	Running At Speed	Zero Speed	Drive Active	Drive Healthy

The fieldbus status word is mapped directly from the drive status word, Pr **10.40**.

Pr **10.40**, is generated by the values of several individual drive status bits Table 9.3 shows the function indicated by each bit in the status word when set to 1.

**Table 9.3 Drive status word bit functions**

Bit	Function	Parameter	Description
0	<b>Drive healthy</b>	Pr 10.01	Indicates the drive is not in the trip state.
1	<b>Drive active</b>	Pr 10.02	Indicates that the output stage of the drive is active.
2	<b>Zero speed</b>	Pr 10.03	In Open Loop mode, zero speed indicates that the absolute value of the post-ramp speed reference is at or below the zero speed threshold. <i>Unidrive SP only</i> - In Closed Loop and Servo modes, zero speed indicates that the absolute value of speed feedback is at or below the zero speed threshold.
3	<b>Running at or below minimum speed</b>	Pr 10.04	In bipolar mode (Pr 1.10 = 1) Pr 10.04 is the same as zero speed, Pr 10.03. (See above.) In unipolar mode, Pr 10.04 is set if the absolute value of the post-ramp speed reference (Pr 2.01) or speed feedback (Pr 3.02) is at or below minimum speed + 0.5Hz or 5rpm. (Minimum speed is defined by Pr 1.07.) This parameter is only set if the drive is running.
4	<b>Below set speed</b>	Pr 10.05	Only set if the drive is running at below set speed. Refer to Pr 3.06, Pr 3.07 and Pr 3.09 in the drive User Guide for more details.
5	<b>At speed</b>	Pr 10.06	Only set if the drive is running at set speed. Refer to Pr 3.06, Pr 3.07 and Pr 3.09 in the drive User Guide.
6	<b>Above set speed</b>	Pr 10.07	Only set if the drive is running at above set speed. Refer to Pr 3.06, Pr 3.07 and Pr 3.09 in the drive User Guide for more details.
7	<b>Load reached</b>	Pr 10.08	Indicates that the modulus of the active current is greater or equal to the rated active current, as defined in menu 4. Refer to the drive <i>Advanced User Guide</i> for more details.
8	<b>In current limit</b>	Pr 10.09	Indicates that the current limits are active.
9	<b>Regenerating</b>	Pr 10.10	Unidrive SP Only: regenerating indicates that power is being transferred from the motor to the drive. In regen mode, regenerating indicates that power is being transferred from the Unidrive SP to the supply.
10	<b>Dynamic brake active</b>	Pr 10.11	Indicates that the braking IGBT is active. If the IGBT becomes active, this parameter will remain on for at least one second.
11	<b>Dynamic brake alarm</b>	Pr 10.12	Dynamic brake alarm is set when the braking IGBT is active, and the braking energy accumulator is greater than 75%.
12	<b>Direction commanded</b>	Pr 10.13	Direction commanded is set to 1 if the Pre-ramp speed reference (Pr 1.03) is negative and reset to 0 if the Pre-ramp speed reference is zero or positive.
13	<b>Direction running</b>	Pr 10.14	A 0 indicates forward direction and a 1 indicates reverse direction. The source of this bit is Pr 2.01 for open loop mode and Pr 3.02 for closed loop and servo modes.
14	<b>Mains loss</b>	Pr 10.15	Mains loss indicates that the drive has detected a mains loss from the level of the DC bus voltage. This parameter can only become active if mains loss ride through or mains loss stop modes are selected. Refer to Pr 6.03 in the <i>drive Advanced User Guide</i> for more details. <i>Unidrive SP only</i> - In regen mode, mains loss is the inverse of Pr 3.07. Refer to the <i>Unidrive SP Advanced User Guide</i> for more details.
15		Not Used	Reserved.

Safety Information
Introduction
Mechanical Installation
Electrical Installation
Getting Started
EDS Files
Cyclic Data
Non-Cyclic Data
<b>Control and Status Words</b>
Diagnostics
Advanced Features
CANopen Reference
Quick Reference
Glossary Of Terms
Index

# 10 Diagnostics

This section provides basic diagnostic information intended to enable the resolution of the most common problems encountered when setting up SM-CANopen on a network. A high percentage of problems reported are basic set-up problems that can be avoided. Start by using the flow chart (Figure 10-1) to determine the possible cause of a problem. If after following the flow chart you are still experiencing problems please contact your supplier or local drive centre for support.

Before requesting support please ensure that you have read the following section and have recorded the firmware/system file versions for SM-CANopen, the drive and SM-Applications where applicable, see Chapter 5 *Getting Started* on page 25 for more information on configuration.

**Figure 10-1 Diagnostic flow chart**

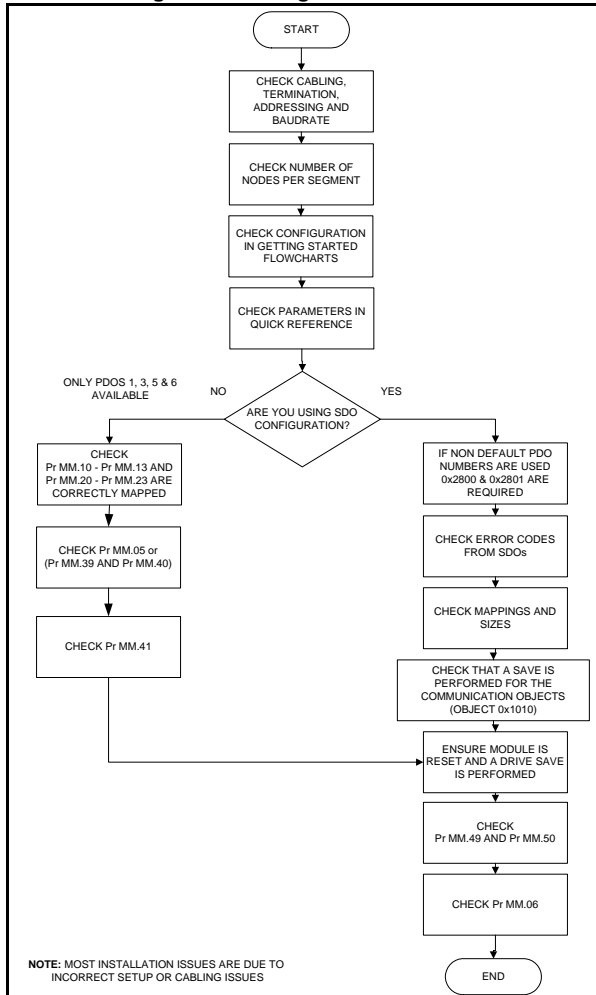

## 10.1 Module ID code

SM-CANopen Module ID code		
Pr MM.01	Default	N/A
	Range	408
	Access	RO

The module ID code indicates the type of Solutions Module that is fitted in the corresponding slot, this should be checked to ensure the correct module is fitted.

## 10.2 SM-CANopen firmware version

SM-CANopen firmware - major version		
Pr MM.02	Default	N/A
	Range	00.00 to 99.99
	Access	RO

SM-CANopen firmware - minor version		
Pr MM.51	Default	N/A
	Range	0 to 99
	Access	RO

The full version of the SM-CANopen firmware can be read for the corresponding slot. Table 10.1 shows how to construct the full firmware version from these values. This version number will be required for technical support.

**Table 10.1 SM-CANopen firmware version**

Major version	Minor version	Firmware version
03.01	0	V03.01.00

## 10.3 SM-CANopen node address

SM-CANopen node address		
Pr MM.03	Default	0
	Range	0 to 127
	Access	RW

Every node on a CANopen network must be given a unique network node address. If two or more nodes are assigned the same node address, network errors may result as 2 nodes attempt to transmit at the same time. The valid range for the node address is 1 to 127, with a default address of 0. The SM-CANopen must be reset to make a change of node address take effect, see section 5.12 *Resetting the SM-CANopen (re-initialising)* on page 43.

If an invalid node address is set SM-CANopen will over-write the value in Pr **MM.03** with 0. When the SM-CANopen is reset the value in this parameter will be used as the CANopen node address.

**NOTE** A node address of 0 will disable the DS301 CANopen communications layer, however the DSP305 V1.1 Layer Setting Service (LSS) will still be active.

## 10.4 SM-CANopen data rate

SM-CANopen data rate		
Pr MM.04	Default	2
	Range	-1 to 8
	Access	RW

Every node on a CANopen network must be configured to run at the same network data rate. If a node is configured with the wrong data rate, it may cause errors on the CAN network, and eventually trip on “SLx.Er” with error code of 66. The SM-CANopen must be reset to make a change of data rate take effect (see section 5.12 *Resetting the SM-CANopen (re-initialising)* on page 43).

If an invalid data rate is set, the SM-CANopen will reject the configured data rate and revert to the nearest valid setting. The default data rate is 500Kbits/s.

**Table 10.2 SM-CANopen data rates**

Pr MM.04	bits/s		Pr MM.04	bits/s
-1	Auto		4	125K
0	1.0M		5	100K
1	800K		6	50K
2	500K		7	20K
3	250K		8	10K

SM-CANopen can automatically detect the network data rate by setting Pr **MM.04** to -1. The SM-CANopen will monitor the CAN network and if the data rate is detected, it will set Pr **MM.04** to indicate the detected data rate. However, it should be noted that the new value of Pr **MM.04** will NOT be stored (this would require a drive save).

**NOTE**

The SM-CANopen may have problems detecting the network data rate if there is little traffic on the CANopen network. Auto-detection of the data rate is ideal when connecting a new node to an existing network, but may not work reliably if a network is powered up with all nodes attempting to detect the network data rate.

## 10.5 SM-CANopen operating status

CANopen operating status		
Pr MM.06	Default	N/A
	Range	-10 to 9999
	Access	RO

The CANopen network activity can be monitored in the SM-CANopen operating status parameter, Pr **MM.06**. When the SM-CANopen is communicating successfully with the CANopen master controller, the SM-CANopen operating status will give an indication of the number of data messages per second that are being processed.

**NOTE**

In version 03.01.00 and earlier Pr **MM.06** includes all received PDOs, SYNC messages and all transmitted PDOs. The network loss trip (as defined by Pr **MM.07**) will occur if non of the above events occurs within the specified time period. This scheme means that if a TxPDO is configured to transmit on a timer or an event, a network loss trip will not occur even if the network cable is removed.

**NOTE**

In version 03.01.01 and later Pr **MM.06** includes all received PDOs, SYNC messages and all transmitted messages of any type. The network loss trip (as defined by Pr **MM.07**) will occur if no data is received within the specified time period. This scheme means that even if a TxPDO is configured to transmit on a timer or an event, a network loss trip will occur even if the network cable is removed.

If a configuration or network error is detected, the drive may trip. This prevents transmitted PDOs from timer or event transactions, preventing a network loss trip as defined in Pr **MM.07**.

**Table 10.3**

Pr <b>MM.06</b>	Parameter	Description
>0	Network healthy	Indicates the number of successful network cycles per second.
0	Network healthy, no data transfer	Indicates that the CANopen master has established communications with SM-CANopen, but there is currently no data transfer in progress.
-1	Initialised	Indicates that SM-CANopen has initialised correctly and is waiting for the CANopen master to initialise communications.
-2	Internal hardware failure	Indicates that part of the SM-CANopen initialisation sequence was not successful. If this fault persists after a power cycle, replace the SM-CANopen.
-3	Configuration error	Indicates that there is an invalid setting in the SM-CANopen configuration parameters see section 10.6 <i>SM-CANopen mapping status</i> on page 73 and section 10.7 <i>SM-CANopen error code</i> on page 76 for further diagnostic details.
-4	Unrecoverable software error	An internal software error has occurred. Reset the SM-CANopen to clear, if error persists, replace the SM-CANopen.
-8	Data rate detection in progress	The SM-CANopen is currently attempting to detect the CANopen network data rate.
-10	Device disabled	Indicates that the DS301 V1.1 CANopen communications layer has been disabled by setting the node address to 0.

## 10.6 SM-CANopen mapping status

SM-CANopen mapping status		
Pr <b>MM.49</b>	Default	0
	Range	0 to 255
	Access	RO

If the SM-CANopen operating status parameter (Pr **MM.06**) indicates “-3”, a mapping configuration error has been detected. The reason for the error is indicated by the SM-CANopen mapping status parameter (Pr **MM.49**). When a mapping error has been corrected, reset SM-CANopen by setting Pr **MM.32** to ON (this will revert immediately to 0).

**Table 10.4 Generic mapping error codes**

Error	Mapping status	Description
No error detected	0	No error detected with the IN or OUT cyclic data mapping configuration.
Direct data mapping error	2	Non-cyclic data cannot be used when direct data mapping is enabled.
Invalid non-cyclic mode	3	An invalid non-cyclic data mode has been selected in Pr <b>MM.05</b> .
Invalid mode value	5	The value entered in Pr <b>MM.05</b> is not supported.
Multiple non-cyclic mapping error	104	A non-cyclic data has been mapped more than once in the IN data mapping configuration parameters (Pr <b>MM.10</b> to Pr <b>MM.13</b> ).
Configuration read error	110	An error has occurred reading the IN cyclic data mapping configuration parameters (Pr <b>MM.10</b> to Pr <b>MM.13</b> ) from the host drive.
Invalid source parameter	111	One or more parameters specified in the IN cyclic data mapping configuration (Pr <b>MM.10</b> to Pr <b>MM.13</b> ) is outside of the allowed range for CANopen. The allowable parameter range is from Pr <b>0.00</b> to Pr <b>199.99</b> .
Read mismatch	112	One or more parameters specified in the IN cyclic data mapping configuration (Pr <b>MM.10</b> to Pr <b>MM.13</b> ) cannot be used as a source parameter for IN data. The parameter may not exist, or is a write-only parameter.
Hole in the IN data mapping configuration	113	IN cyclic data mapping parameters (Pr <b>MM.10</b> to Pr <b>MM.13</b> ) are not contiguous. It is not possible to have an un-used parameter in the middle of the cyclic data.
Inter-option communications error	115	A request to set up an inter-option communications block failed. Either the server does not support block transfer or parameters were not legal.
Too many IN data objects mapped	120	After expanding ranges of block mappings, too many IN cyclic data channels are configured.
Mapping over length	121	Total size of all IN cyclic data mappings has exceeded the total size of the cyclic data.
Register mode objects exceeded	122	More than 10 cyclic IN data channels have been selected with direct data mapping mode.
Multiple non-cyclic mapping error	204	A non-cyclic data mode has been mapped more than once in the OUT cyclic data mapping configuration parameters. (Pr <b>MM.20</b> to Pr <b>MM.23</b> )
Configuration read error	210	An error has occurred reading the OUT cyclic data mapping configuration parameters (Pr <b>MM.20</b> to Pr <b>MM.23</b> ) from the drive.
Invalid destination parameter	211	One or more parameters specified in the OUT cyclic data mapping configuration (Pr <b>MM.20</b> to Pr <b>MM.23</b> ) is outside of the allowed range for CANopen. The allowable parameter range is from Pr <b>0.00</b> to Pr <b>199.99</b> .
Write mismatch	212	One or more parameters specified in the OUT cyclic data mapping configuration (Pr <b>MM.20</b> to Pr <b>MM.23</b> ) cannot be used as a destination parameter for OUT data. The parameter may not exist, or is a read-only parameter. This error will also occur if an attempt is made to map OUT data to the configuration parameters of a fieldbus option in another slot, unless that fieldbus is configured in direct data access mode, i.e. Pr <b>MM.09</b> = ON (1).

**Table 10.4 Generic mapping error codes**

Error	Mapping status	Description
Hole in OUT data mapping configuration	213	OUT data mapping parameters (Pr <b>MM.20</b> to Pr <b>MM.23</b> ) are not contiguous. It is not possible to have an un-used parameter in the middle of the cyclic data.
Duplicate mapping error	214	Two or more OUT cyclic data mapping configuration parameters (Pr <b>MM.20</b> to Pr <b>MM.23</b> ) have been configured with the same destination parameter reference.
Inter-option communications error	215	A request to set up an inter-option communications block failed. Either the server does not support block transfer or parameters were not legal.
Too many OUT data objects mapped	220	After expanding ranges of block mappings, too many OUT cyclic data channels configured.
Mapping over length	221	Total size of all OUT cyclic data mappings has exceeded the total size of the cyclic data.
Register mode objects exceeded	222	More than 10 cyclic OUT data channels have been selected with direct data mapping mode.

There are some additional error codes that are specific to the SM-CANopen. These are listed in Table 10.5.

**Table 10.5 SM-CANopen specific mapping error codes**

Error	Mapping status	Description
Invalid transmission type	30	The transmission type selected for TxPDOA is not supported.
Cannot override objects	31	Parameter Pr <b>MM.42</b> is set, but SM-CANopen has not detected an SM-Applications fitted to the drive.
DSP402 enabled and direct data mapping selected	32	Direct data mapping (Pr <b>MM.09</b> ) and DSP402 device profiles (Pr <b>MM.37</b> ) are both enabled. They cannot be enabled together.
DSP402 enabled and data format selected	33	A data format has been specified in Pr <b>MM.05</b> and DSP402 device profiles (Pr <b>MM.37</b> ) are both enabled, they cannot be enabled together.
DSP402 enabled without data compression	34	Data compression (Pr <b>MM.34</b> ) must be enabled to allow the DSP402 device profiles to be used.
No data mode selected	35	No data mode has been specified in Pr <b>MM.05</b> , Pr <b>MM.37</b> , Pr <b>MM.39</b> or Pr <b>MM.40</b> .

Safety Information
Introduction
Mechanical Installation
Electrical Installation
Getting Started
EFS Files
Cyclic Data
Non-Cyclic Data
Control and Status Words
Diagnostics
Advanced Features
CANopen Reference
Quick Reference
Glossary Of Terms
Index

## 10.7 SM-CANopen error code

SM-CANopen error code		
Pr <b>MM.50</b>	Default	N/A
	Range	0 to 255
	Access	RO

If the SM-CANopen detects an error during operation, it will force a trip on the drive and update the SM-CANopen error code parameter (Pr **MM.49**). Table 10.6 shows the SM-CANopen error codes.

**Table 10.6 SM-CANopen error codes**

Error code	Fault	Description
0	No error detected	Indicates that the trip was not caused by the SM-CANopen. It is possible to trip the drive externally via various communication channels.
52	User control word trip	The TRIP bit has been set in the drive control word.
61	Configuration error	An invalid configuration has been detected. Refer to mapping status parameter (Pr <b>MM.49</b> ) for the configuration error code.
65	Network loss	No new messages have been received for the specified network loss trip time.
66	Bus off error	The CAN controller has seen an excessive number of transmission errors, and has taken itself off the CANopen network. This error can be caused by incorrect network wiring, wrong data rate configured, or a duplicate node address has been set.
70	FLASH transfer error	The SM-CANopen module was unable to upload the configuration parameters from its FLASH memory to the drive.
74	SM-CANopen over temperature	The temperature inside the SM-CANopen has exceeded 82°C.
80	Inter-option communication error	Communications time-out has occurred, but SM-CANopen is unable to determine the reason for the error.
81	Communication error to slot 1	Direct communications between the SM-CANopen and an SM-Applications in another slot has timed out. This can occur when the SM-CANopen has been mapped to directly read or write PLC registers in an SM-Applications, and the SM-Applications has been reset. This may also indicate problems communicating with the host drive.
82	Communication error to slot 2 *	
83	Communication error to slot 3 *	
98	Internal watchdog error	Internal error. Cycle power to the drive to reset from this trip.
99	Internal software error	If trip persists, contact Control Techniques for further assistance.

\* Unidrive SP only.

## 10.8 Stuff Bits

Stuff bits are used by CANopen to ensure that each CANopen device does not transmit a long stream of consecutive 1s or 0s. The number of stuff bits in a CANopen frame depends mainly on the values in the data bytes of the CANopen frame (a series of bytes with 0x00 or 0xFF will produce most stuff bits). The maximum recommended load factor of 0.85 accounts for the worst case number of CANopen stuff bits that may be transmitted in a single frame.

If stuff bits have already been accounted for in the number of bits for each PDO, the network load factor must be < 1.0 for the network to work reliably.

**NOTE** Remember the stuff bit will make values appear to be incorrect when looking at the network with an oscilloscope.

Safety Information
Introduction
Mechanical Installation
Electrical Installation
Getting Started
EDS Files
Cyclic Data
Non-Cyclic Data
Control and Status Words
<b>Diagnostics</b>
Advanced Features
CANopen Reference
Quick Reference
Glossary Of Terms
Index

# 11 Advanced Features

## 11.1 SM-CANOpen network loss trip time-out

SM-CANOpen network loss trip time-out		
Pr <b>MM.07</b>	Default	200
	Range	0 to 3000
	Access	RW

SM-CANOpen resets an internal timer when a valid message is received from the CANOpen network. The network loss trip is triggered when no new messages are received before the timer times out. The SM-CANOpen will trip the drive and the SM-CANOpen error code parameter (Pr **MM.50**) will show 65.

After power-up or reset the network loss trip is not armed until one of the following events occur:

- SYNC message is received.
- RxPDO is received.

Once the trip has been armed, a minimum of one of the above messages must be received or transmitted in each time period. If this does not happen SM-CANOpen will trip the drive.

Figure 11-1 SM-CANOpen network loss trip

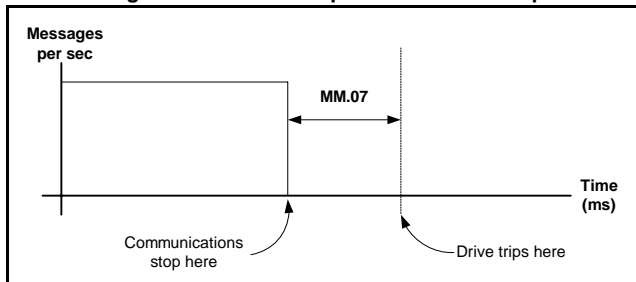

As the trip delay time is reduced, the network loss trip will occur more quickly in the event of a loss of network. However, if the network loss trip time is reduced too far, spurious network loss trips may occur due to time-out occurring before the next message has chance to arrive. The network loss trip time should be set such that a minimum of 4 messages will be received in the specified time period under normal operating conditions.

**NOTE** The network loss trip can be disabled by setting Pr **MM.07** to 0. In this case, the drive will continue to operate using the last received values. It is the user's responsibility to ensure that adequate safety precautions are taken to prevent damage or injury by disabling the drive in the event of a loss of communications.

**NOTE**

In version (03.01.00) or earlier, the following applies. Pr **MM.06** includes all received PDOs and SYNC messages and all transmitted PDO messages. The network loss trip occurs if no SYNC or PDOs are received and no PDOs transmitted within the trip time period (Pr **MM.07**). Please refer to section 11.1 *SM-CANopen network loss trip time-out* on page 78 for further details on Pr **MM.07**.

In version (03.01.01) and later the following applies. Pr **MM.06** includes all received PDOs and SYNC messages and ALL transmitted messages of ANY type. The network loss trip will occur if no SYNC or PDOs are received within the trip time period. ALL transmitted messages will be ignored. Please refer to section 10.5 *SM-CANopen operating status* on page 72 for further detail on Pr **MM.06**.

## 11.2 SM-CANopen data endian format

SM-CANopen Data endian format		
Pr <b>MM.08</b>	Default	ON (little)
	Range	N/A
	Access	RO

When data is sent over the CANopen network, it is transmitted as 8-bit bytes. This means, when a 32-bit double word or 16-bit word data value is split into four or two 8-bit bytes, it is important that the receiving node reconstructs the received bytes correctly to arrive at the 32-bit or 16-bit data value that was originally transmitted. The order in which 8-bit bytes are transmitted is known as the “data endian format”. For CANopen, the endian format is specified as “little endian”.

**Table 11.1 Data endian format**

Data endian format	Pr <b>MM.08</b>	16-bit value	32-bit value	
		Byte order	Word order	Byte order
Little	1	Low byte first High byte second	Low word first High word second	Low byte first Mid low byte second Mid high byte third High byte fourth

## 11.3 Unidrive SP: inter-option communication timing

When more than one Solutions Module is fitted to a Unidrive-SP, communications between modules uses inter-option communications. Inter-option communications is slower than communication directly to the drive parameters.

Typical access times for direct menu access to the drive menu will be in the region of 30µs (per parameter), a similar access using inter-option communications will be in the region of 1ms (per parameter).

When using inter-option communications, if parameters are sequential (within the same menu) then up to 5 parameters may be grouped in to a block, (although this is limited to 4 by the PDO size) this will take up to 1ms for this block to be transferred. A maximum of 8 blocks for input and 8 blocks for output are available.

Safety Information
Introduction
Mechanical Installation
Electrical Installation
Getting Started
EPS Files
Cyclic Data
Non-Cyclic Data
Control and Status Words
Diagnosics
<b>Advanced Features</b>
CANopen Reference
Quick Reference
Glossary Of Terms
Index

## 11.4 Local Solutions Module parameter access

The menu used to configure the SM-CANopen depends on the slot in the Unidrive SP where SM-CANopen is fitted. Menu 60 can be used to ensure that the CANopen configuration parameters can be accessed without necessarily knowing in which drive slot the SM-CANopen is fitted, this can also be used for Commander SK/SX.

When a Menu 60 parameter is accessed from CANopen, the SM-CANopen will re-direct it to the menu that is associated with the slot where the SM-CANopen is fitted.

## 11.5 Unidrive SP: mapping To SM-Applications parameters

SM-CANopen can read and write data directly to and from internal registers in SM-Applications. Six sets of 32-bit registers are accessible in SM-Applications (additional information is available in section 11.6 *Unidrive SP: block mapping* on page 81), each register in SM-Applications can be accessed as a virtual parameter.

SM-CANopen can be configured to read data from and write data to an SM-Applications fitted in any slot in the Unidrive SP by specifying the target parameter as shown in Table 11.2.

**Table 11.2 SM-Applications internal parameters**

SM-Applications parameters	Parameter reference	Direct to slot 1	Direct to slot 2	Direct to slot 3
_Pxx% PLC Registers	Pr 70.xx	Pr 100.xx	Pr 130.xx	Pr 160.xx
_Qxx% PLC Registers	Pr 71.xx	Pr 101.xx	Pr 131.xx	Pr 161.xx
_Rxx% PLC Registers	Pr 72.xx	Pr 102.xx	Pr 132.xx	Pr 162.xx
_Sxx% PLC Registers	Pr 73.xx	Pr 103.xx	Pr 133.xx	Pr 163.xx
_Txx% PLC Registers	Pr 74.xx	Pr 104.xx	Pr 134.xx	Pr 164.xx
_Uxx% PLC Registers	Pr 75.xx	Pr 105.xx	Pr 135.xx	Pr 165.xx
Local Configuration Parameters	Pr 81.xx	Pr 111.xx	Pr 141.xx	Pr 171.xx
Timer Function Parameters	Pr 85.xx	Pr 115.xx	Pr 145.xx	Pr 175.xx
Digital I/O Parameters	Pr 86.xx	Pr 116.xx	Pr 146.xx	Pr 176.xx
Status Parameters	Pr 88.xx	Pr 118.xx	Pr 148.xx	Pr 178.xx
General Parameters	Pr 90.xx	Pr 120.xx	Pr 150.xx	Pr 180.xx
Fast Access Parameters	Pr 91.xx	Pr 121.xx	Pr 151.xx	Pr 181.xx

If the SM-CANopen is configured to map data to Pr 70.xx and Pr 91.xx parameters, data will be exchanged with the SM-Applications fitted in the lowest slot number. This method is convenient to use if there is only one SM-Applications fitted to the Unidrive SP, as it guarantees that data will always be written to the SM-Applications, even if it is moved to a different slot. If two SM-Applications are fitted, it is best to map directly to the required slot.

### 11.5.1 Unidrive SP: single SM-Applications fitted

Consider a Unidrive SP with the following configuration:

- Slot 1 - Vacant
- Slot 2 - SM-Applications.
- Slot 3 - SM-CANopen.

If a parameter read request comes over CANopen to read Pr **71.08**, this will be re-directed to the SM-Applications in the lowest slot number, i.e. the SM-Applications in slot 2. The value in `_Q08%` from slot 2 will be returned.

If a parameter read request comes over CANopen to read Pr **131.08**, this will be sent straight to the SM-Applications in slot 2. The value in `_Q08%` from slot 2 will be returned.

If a parameter read request comes over CANopen to read Pr **101.08**, this will be sent straight to the SM-Applications in slot 1. As there is no SM-Applications fitted in slot 1, an error message will be returned, indicating that the parameter does not exist.

If a single SM-Applications is fitted to the Unidrive SP, normal SM-Applications parameter references can be used without problem, as the SM-CANopen will automatically divert them to the SM-Applications.

### 11.5.2 Unidrive SP: dual SM-Applications fitted

Consider a Unidrive SP with the following configuration:

- Slot 1 - SM-Applications.
- Slot 2 - SM-Applications.
- Slot 3 - SM-CANopen.

If a parameter read request comes over CANopen to read Pr **71.08**, this will be re-directed to the SM-Applications in the lowest slot number, i.e. the SM-Applications in slot 1. The value in `_Q08%` from slot 1 will be returned.

If a parameter read request comes over CANopen to read Pr **131.08**, this will be sent straight to the SM-Applications in slot 2. The value in `_Q08%` from slot 2 will be returned.

If a parameter read request comes over CANopen to read Pr **101.08**, this will be sent straight to the SM-Applications in slot 1. The value in `_Q08%` from slot 1 will be returned.

**NOTE**

If two SM-Applications are fitted to the Unidrive SP, it is best to access SM-Applications parameters using the direct slot parameter references. If normal SM-Applications parameter references are used, and the SM-Applications is removed from slot 1, these parameter references will be re-directed to slot 2 instead.

## 11.6 Unidrive SP: block mapping

On SM-CANopen there are 4 used mapping parameters available for both input (4) and output mappings(4). Block mapping is configured by placing ascending parameters (within the same menu) in to consecutive mapping parameters. Consider the example in Table 11.3.

**NOTE**

Block mapping is only available when using Pr **18.xx**, Pr **19.xx**, Pr **20.xx** and on the PLC registers within SM-Applications. Commander SX does not support this feature.

**Table 11.3 Block Mapping Example**

Mapping parameter	Mapping value	Description
Pr <b>MM.10</b>	1811	Map to 1811 as the start for the block mapping.
Pr <b>MM.11</b>	1814	Map to 1814 as the end for the block mapping.
Pr <b>MM.20</b>	1815	Map to 1815 as the start for the block mapping.
Pr <b>MM.21</b>	1818	Map to 1818 as the end for the block mapping.

This will map parameters Pr **18.11** to Pr **18.12** and Pr **18.13** to Pr **18.14** giving a total of 8 mappings, using only 4 of the mapping parameters as shown in Table 11-2.

**Figure 11-2 Block Mapping Expansions**

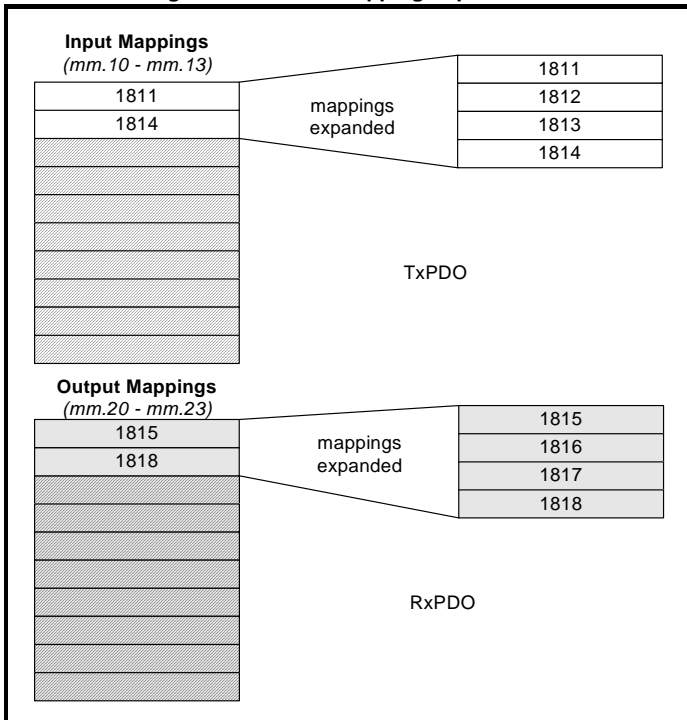

Block mapping can also be used when mapping data to the PLC registers in SM-Applications. If it is required to map to individual parameters within the same menu ensure that the target registers are listed in descending order (see section 11.6.1 *Avoiding block mapping*).

## 11.6.1 Avoiding block mapping

In the above section block mapping was used to define mapping ranges. In order to avoid this the target parameters should be entered in descending order. This means that SM-CANopen will not recognise a range of parameters and only 2 parameters will be mapped.

**Table 11.4 Non-block data mapping example**

Mapping parameter	Mapping value	Description
Pr <b>MM.10</b>	2004	Map to Pr 20.04.
Pr <b>MM.11</b>	2001	Map to Pr 20.01.
Pr <b>MM.12</b> to Pr <b>MM.13</b>	0	Not mapped
Pr <b>MM.20</b>	2035	Map to Pr <b>20.35</b>
Pr <b>MM.21</b>	2031	Map to Pr <b>20.31</b>
Pr <b>MM.22</b> to Pr <b>MM.23</b>	0	Not mapped

## 11.7 Direct data mapping

SM-CANopen Direct data mapping enable		
Pr <b>MM.09</b>	Default	OFF (0)
	Range	OFF (0) or ON (1)
	Access	RW

By default, Pr **MM.10** to Pr **MM.13** and Pr **MM.20** to Pr **MM.23** are used as pointers to specify the destination parameter for OUT data received from the master controller, and the source parameter of IN data to be transmitted to the master controller, for PDOA.

When direct data mapping is enabled, Pr **MM.10** to Pr **MM.13** and Pr **MM.20** to Pr **MM.23** are used as the actual destination and source parameters for OUT data and IN data respectively.

**NOTE** CT Single Word and PPO 4 Word non-cyclic data modes cannot be used when direct mapping is enabled.

When direct data mapping mode is enabled all mapping parameters (Pr **MM.10** to Pr **MM.13** and Pr **MM.20** to Pr **MM.23**) will be reset to 0. When data compression is OFF, the number of data words specified in Pr **MM.05** must be an even number. If an odd number is specified the appropriate parameter will be set to specify the next lowest even number of data words, (i.e. a value of 7 in Pr **MM.05** will only handle 6 data words or 3 data channels).

**Table 11.5 Direct data mapping configurations (data compression OFF)**

Pr <b>MM.05</b>	Description
2 to 4	The 2 channels on RxPDOA will be written directly to Pr <b>MM.10</b> and Pr <b>MM.11</b> , and the 2 channels on TxPDOA will be read directly from Pr <b>MM.20</b> to Pr <b>MM.21</b> .

Parameters Pr **MM.10** to Pr **MM.13** and Pr **MM.20** to Pr **MM.23** are all 16-bit parameters, so each data channel will be reduced to 16-bits when data compression is enabled. Hence, a maximum of 4 channels can be created when using direct data mapping.

**Table 11.6 Direct data mapping configurations (data compression ON)**

Pr <b>MM.05</b>	Description
1 to 8	The 4 channels on RxPDOA will be written directly to Pr <b>MM.10</b> to Pr <b>MM.13</b> , and the 4 channels on TxPDOA will be read directly from Pr <b>MM.20</b> to Pr <b>MM.23</b> .

## 11.8 Cyclic data compression

SM-CANopen Cyclic data compression enable		
Pr <b>MM.34</b>	Default	OFF (0)
	Range	OFF (0) or ON (1)
	Access	RW

By default SM-CANopen uses 32-bits (i.e. 2 data words, for each data channel) even if the target source parameter in the drive is a 16-bit parameter. This strategy ensures that the cyclic data transmitted over the CANopen network is kept aligned with memory locations in new 32-bit PLCs.

Table 11.7 shows an example set of mapping parameters where 2 IN and 2 OUT cyclic data channels are required for RxPDOA and TxPDOA. With data compression disabled, each data channel uses 32-bits (i.e. 2 data words, so a total of 6 words are required). This is not possible for the SM-CANopen as this exceeds the size of the PDO.

**Table 11.7 Example cyclic data channel mapping**

Data channel	Data words used	Mapping for slot	Setting	Data width	Mapping status
IN channel 0	IN word 0, 1	Pr <b>MM.10</b>	1040	16-bit	Pr <b>10.40</b> , status word
IN channel 1	IN word 2, 3	Pr <b>MM.11</b>	201	32-bit	Pr <b>2.01</b> , post-ramp speed ref
OUT channel 0	OUT word 0, 1	Pr <b>MM.20</b>	642	16-bit	Pr <b>6.42</b> , control word
OUT channel 1	OUT word 2, 3	Pr <b>MM.21</b>	121	32-bit	Pr <b>1.21</b> , digital speed ref 1

When data compression is enabled by setting Pr **MM.34** = ON, a data channel will only use 32 bits if the target drive parameter is a 32 bit parameter. If the target drive parameter for a data channel is only 1, 8 or 16 bits wide, only 16 bits will be used for that particular data channel. Hence, the IN and OUT data will now only use a total of 3 words, so Pr **MM.05** can now be set to 3 and the data format can be handled by RxPDOA and TxPDOA. This also applies to mappings performed over SDO.

## 11.9 Unidrive SP: event task trigger in SM-Applications

Slot	SM-Applications EVENT task trigger		
Slot 1	Pr <b>61.41</b>	Default	0
Slot 2	Pr <b>61.42</b>	Range	0 to 4
Slot 3	Pr <b>61.43</b>	Access	WO

The SM-Applications has 4 EVENT tasks available for use in the DPL Program and the SM-CANopen can be configured to trigger one of these tasks.

An EVENT task is triggered when the trigger parameter is actually written to while the value (1 to 4) determines which task is actually triggered. The task trigger parameter can be written to using cyclic or non-cyclic data.

**Table 11.8 EVENT task trigger parameters**

Trigger parameter	Value written to trigger parameter				
	0	1	2	3	4
Pr 61.40*	No action	EVENT*	EVENT1*	EVENT2*	EVENT3*
Pr 61.41	No action	EVENT task in slot 1	EVENT1 task in slot 1	EVENT2 task in slot 1	EVENT3 task in slot 1
Pr 61.42	No action	EVENT task in slot 2	EVENT1 task in slot 2	EVENT2 task in slot 2	EVENT3 task in slot 2
Pr 61.43	No action	EVENT task in slot 3	EVENT1 task in slot 3	EVENT2 task in slot 3	EVENT3 task in slot 3

**NOTE**

\*The specified EVENT task will be triggered in the SM-Applications fitted in the lowest slot number on the Unidrive SP.

When an EVENT task runs in the SM-Applications, the Reason Code parameter (Pr 90.12 to Pr 90.15 for EVENT to EVENT3 task respectively) will indicate why the event task was triggered. The reason codes for Solution Modules are shown in Table 11.9 (refer to the *SM-Applications User Guide* for full details).

**Table 11.9 EVENT task reason codes**

Solution Module	Reason code
SM-DeviceNet	1
SM-PROFIBUS-DP	2
SM-CANopen	3
SM-INTERBUS	4
SM-CAN	5

If cyclic data is used to trigger an EVENT task in an SM-Applications, it is best to map the last OUT cyclic data word to the EVENT task trigger parameter. As cyclic data is written to destination parameters in the order in which it is received, this guarantees that all received cyclic data will have been written to the target parameters BEFORE the EVENT task runs in the SM-Applications. This can be useful for ensuring data is present in the drive before executing code that relies on the values passed across the network.

## 11.10 PDOA length

Name	TxPDOA length (default PDO1)	
Pr MM.39	Default	4
	Range	0 to 4
	Access	RW

Name	RxPDOA length (default PDO1)	
Pr MM.40	Default	4
	Range	0 to 4
	Access	RW

If the number of words is specified using the SM-CANopen data format parameter,

Pr **MM.05**, the number of words in RxPDOA and TxPDOA will be the same. When Pr **MM.05** is set to 0, the TxPDOA and RxPDOA data lengths can be specified separately in Pr **MM.39** and Pr **MM.40** respectively. This allows different numbers of data words to be specified for RxPDOA and TxPDOA.

**NOTE** The default PDO number for RxPDOA and TxPDOA is 1.

## 11.11 PDO counter

Name	PDO counter (RxPDOA counter)	
	Pr <b>MM.46</b>	<b>Default</b>
<b>Range</b>		0 to 255
<b>Access</b>		RO

The PDO counter is incremented by 1 whenever a complete RxPDOA (by default 1) is received. The PDO counter will roll over to 0 when it reaches 255. This is of particular use for ensuring the transfer of data is completed before using values passed across the network. This can be utilised to compensate for synchronisation signals with excessive jitter.

## 11.12 Unidrive SP: linking object dictionary entries to DPL program variables

Integer variables in an SM-Applications DPL program can be associated with the CANopen object dictionary, allowing the CANopen master controller to directly read from and write to DPL variables. Associations can only be made during the INITIAL task of the DPL program.

### 11.12.1 DPL function call

The DPL function **ASSOCIATEINTOPCOMMS** is used to create an association and define attributes of the associated object. When an association is made the object can be given different attributes to control the size and access rights of the object.

Integer variables in an SM-Applications are signed 32-bit integers. If a DPL variable is associated with an object that is less than 32-bits, it is up to the user to ensure that the DPL variable is kept within the limits of the associated object.

```
Status% = ASSOCIATEINTOPCOMMS(Index%, Sub%, Var%, Sign%, Size%
Read%, Write%)
```

**Table 11.10 ASSOCIATEINTOPCOMMS arguments**

Argument	Range	Description
<b>Index%</b>	0x1000, and 0x3000 to 0x9FFF	Specifies the object index and sub-index references to be used to access the specified DPL variable.
<b>Sub%</b>	0x00 to 0xFF	
<b>Var%</b>	N/A	SM-Applications program DPL variable name that is to be linked to Index% and Sub%.
<b>Sign%</b>	0 or 1	0 = object is unsigned 1 = object is signed
<b>Size%</b>	1, 8, 16 or 32	Specifies the object length in bits.

**Table 11.10 ASSOCIATEINTOPCOMMS arguments**

Argument	Range	Description
Read%	0 or 1	0 = object cannot be read by the SM-CANopen. 1 = object can be read by the SM-CANopen.
Write%	0 or 1	0 = object cannot be written to by the SM-CANopen. 1 = object can be written to by the SM-CANopen.
Status%	0 to 7	Indicates the success or otherwise of the function. See Table 11.11 for full details of status return codes.

**ASSOCIATEINTOPCOMMS** returns the following codes to indicate if the association request was successful or not.

**Table 11.11 ASSOCIATEINTOPCOMMS return values**

Value	Meaning	Description
0	Successful	The association was created successfully.
1	Insufficient heap space	There is less than 12 bytes of space remaining on the user heap
2	Duplicate object	An association for that index and sub-index combination has already been created
3	Invalid index	The index number is not in the range 0x0000 to 0xFFFF.
4	Invalid sub-index	The sub-index number is not in the range 0x0000 to 0xFFFF.
5	Invalid variable	The specified DPL variable does not exist.
6	Illegal task	The association was attempted outside the <b>INITIAL</b> task.
7	Invalid format	The requested combination of format parameters is not valid, e.g. <b>signed%</b> = 1 and <b>size%</b> = 1 (boolean), or a format parameter is an invalid value, e.g. <b>Readable%</b> = 3.

**NOTE** It is very important that object associations are made in the correct order. Refer to section 11.12.5 *Optimisation* on page 88 for further details.

### 11.12.2 Object association rules

Certain rules apply when declaring an object association. If any of these rules are broken, **ASSOCIATEINTOPCOMMS** will return an error code (see Table 11.11).

1. The association must be made in the **INITIAL** task of the user program.
2. There must be sufficient user heap space available to make the object association.
3. An object must be readable and/or writable.
4. An object cannot be boolean and signed.
5. Index and sub-index combination must be unique.
6. Associated DPL variables must be integers.

SM-CANopen object associations use the same SM-Applications memory area as DPL variables and arrays, so the total number of objects associations depends on the number of DPL variables and array locations used in the SM-Applications DPL program. SM-Applications has a total of 80K of heap space available for DPL variables and arrays and each SM-CANopen object association requires 12 bytes of heap space.

Safety Information
Introduction
Mechanical Installation
Electrical Installation
Getting Started
EPS Files
Cyclic Data
Non-Cyclic Data
Control and Status Words
Diagnostics
Advanced Features
CANopen Reference
Quick Reference
Glossary Of Terms
Index

### 11.12.3 Example function call

The following function call will create an association between object 0x6000, sub-index 0x01 and variable `MyVar%`, making a signed 16-bit read-only object. The variable `Status%` will contain the function's return value.

```
Status% = ASSOCIATEINTOPCOMMS ( 0x6000 , 1 , MyVar% , 1 , 16 , 1 , 0 )
```

### 11.12.4 Maintaining DPL variables

When an association is created the size and format attributes are used to control access to the DPL variable from SM-CANopen. SM-Applications will restrict access to the DPL variable, based on the specified attributes (i.e. it will not allow a value to be written to a read-only association).

SM-Applications does not automatically maintain DPL variables that have been associated with the SM-CANopen. The DPL program still has full access and control over all DPL variables, so it is possible for the DPL program to write a full 32-bit value to a DPL variable, even though it has been associated with an 8-bit CANopen object. If the CANopen object is subsequently read, the DPL variable will be masked, and the SM-Applications will only pass the low 8-bits to the SM-CANopen. The same principle applies to boolean and 16-bit objects.

If an association has been created declaring an 8-bit read-only object, the DPL program can still write a new value to the DPL variable, and the complete 32-bit range is still available.

It is possible to have multiple associations with different attributes made to the same DPL variable, provided that the index and sub-index references are unique in each case.

### 11.12.5 Optimisation

In order to make object access as quick as possible at run-time, the stored objects need to be sorted to make searching as fast as possible. Searching also needs to take place during the creation of each association to prevent duplicate associations being created.

The association routine is optimised to create associations in ascending order of the combined index and sub-index numbers. If objects are created in ascending order, each one is added to the end of the search list and no sort is needed.

If an association is added that cannot be placed at the end of the search list, a complete sort of the list takes place. The sort process is relatively slow and only takes place during creation of associations in the INITIAL task.

**NOTE** Creating the maximum possible number of associations in the least optimised order (reverse order) will take tens of minutes, compared to less than a second for creation of the same associations in ascending order.

The number of associations possible is only limited by the amount of available heap space in the SM-Applications. If there is insufficient remaining space, an error will be returned by `ASSOCIATEINTOPCOMMS`, and the association will not be created.

## 11.13 Unidrive SP: SM-Applications object priority

Name	SM-Applications object priority	
Pr MM.42	Default	0
	Range	0 to 2
	Access	RW

When DPL variables are linked to the CANopen object dictionary entries, there is no restriction placed on which objects can be created. If a complete profile was written in DPL code, some objects (e.g. **vl\_target\_velocity**), would exist in SM-CANopen and would also be defined in SM-Applications. SM-Application object priority specifies which object takes priority.

**Table 11.12 SM-Applications object priority**

Value	Priority	Description
0	None	SM-CANopen will check its internal object dictionary for the presence of the specified object. If the specified object does not exist in the SM-CANopen, an error message will be returned. SM-CANopen will NOT check the SM-Application object dictionary.
1	SM-CANopen	SM-CANopen will check its internal object dictionary first for the presence of the specified object. If the specified object does not exist, SM-CANopen will next check the SM-Applications object dictionary. If the specified object does not exist in either module, an error message will be returned.
2	SM-Applications	SM-CANopen will check the SM-Applications object dictionary first for the presence of the requested object. If the specified object does not exist, SM-CANopen will next check its internal object dictionary. If the specified object does not exist in either module, an error message will be returned.

## 11.14 Unidrive SP: synchronised data transfer mode

High speed “Synchronised data transfer mode” is a special mode of operation where the SM-CANopen synchronises the Unidrive SP speed loop and SM-Applications POS tasks with the SYNC message from the CANopen network. This ensures that the Unidrive SP speed loops and SM-Applications POS tasks are synchronised across the CANopen network and will use their new data references at the same time.

### 11.14.1 Overview

In order that the synchronisation scheme can be realised on SM-CANopen, it requires certain criteria to be met in terms of network loading and topology. The restraints imposed by this scheme mean that only a single RxPDO may be transmitted and four TxPDOs may be received by the master in a single synchronisation period of 1ms.

In the example below each PDO comprises 64 bits. The RxPDO is sent by the master and contains four 16 bit references, each drive reads its reference from the appropriate mapping parameter (Pr **MM.20** - Pr **MM.23**).

Each drive receives ¼ of RxPDO1 as a reference and transmits a single 64 bit PDO (one from each drive) as feedback. The PDO values are transferred in the mapping parameters Pr **MM.10** to Pr **MM.13** and Pr **MM.20** to Pr **MM.23**.

More drives may be utilised with this scheme, however it is important to consider how this affects the SYNC timing. If further drives are incorporated into the scheme, the synchronisation period must be increased accordingly. Please refer to Technical Bulletin T051105 for further information, which is available either from your supplier or local drive centre.

Safety Information
Introduction
Mechanical Installation
Electrical Installation
Getting Started
EPS Flashes
Cyclic Data
Non-Cyclic Data
Control and Status Words
Diagnostics
Advanced Features
CANopen Reference
Quick Reference
Glossary Of Terms
Index

Figure 11-3 Transmitted RXPDO and TXPDOs

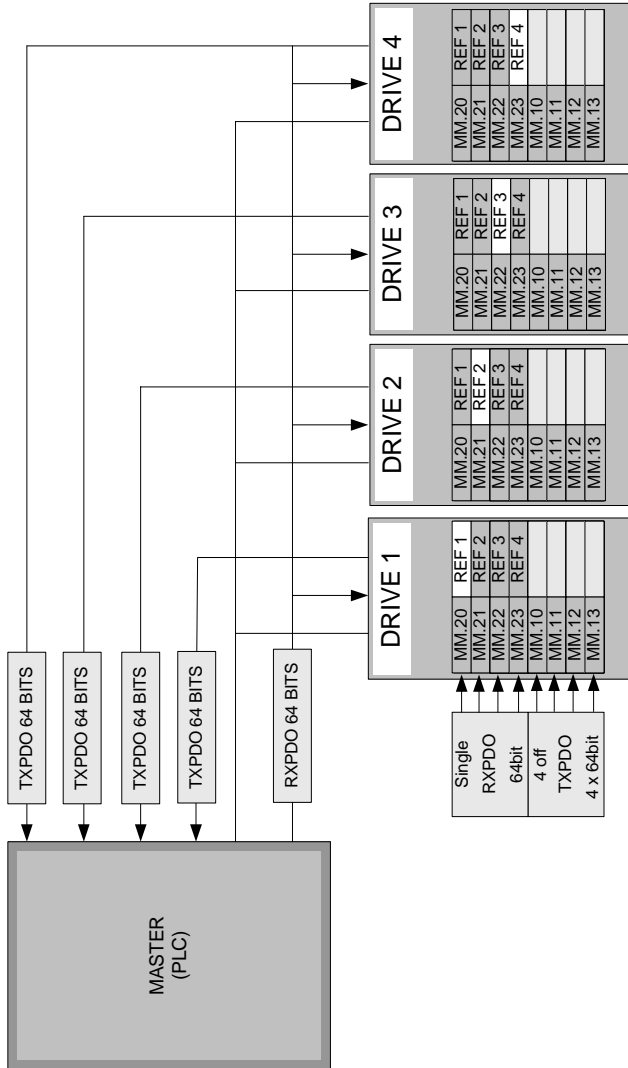

NOTE: Direct data mapping (**MM.09**) must be enabled

## 11.14.2 Configuring synchronised data transfer

The following features must be enabled on SM-CANopen to implement the synchronised data transfer mode:

1. Direct data mapping enabled, set Pr **MM.09** to ON.
2. Data compression enabled, set Pr **MM.34** to ON.
3. Synchronisation producer enabled, set Pr **MM.43** to 1.
4. Transmission type to 1, set Pr **MM.41** to 1.
5. SM-CANopen must be reset by setting Pr **MM.32** to ON to make the configuration changes take effect.
6. Write 1000 to Pr **xx.00** and press the red button to save the parameters.

**NOTE** To use the synchronised data transfer mode, SM-CANopen must be fitted with V3.01.00 or later firmware and SM-Applications must have V1.03.00 or later system file installed.

### 11.14.3 Synchronisation modes

Unidrive SP will allow one of the installed option modules to adjust the timing of the internal loops to keep it synchronised to an external signal. This module is known as the “synchronisation producer” for the Unidrive SP.

**Table 11.13 Synchronisation modes**

Pr <b>MM.43</b>	Mode	Description
0	Independent	SM-CANopen will not participate in the Unidrive SP inter-option synchronisation system.
1	Producer	SM-CANopen will act as the “synchronisation producer” on the Unidrive SP.
2	Consumer	Not valid.

When SM-CANopen is enabled as the synchronisation producer, it will use the CANopen SYNC message as the external synchronisation signal. Every SM-CANopen on a synchronised network must be configured as the synchronisation producer for its Unidrive SP by setting Pr **MM.43** to 1. Please refer to Technical Bulletin T051105 for further information, which is available either from your supplier or local drive centre.

**NOTE** If 2 or more option modules are configured to be the synchronisation producer for the Unidrive SP, the module fitted in the lowest slot will be the synchronisation producer.

When SM-CANopen is enabled as the synchronisation producer, the synchronisation status (Pr **MM.44**) and synchronisation period (Pr **MM.45**) parameters will be updated to indicate the current synchronisation status.

## RxPDOA and TxPDOA mappings

If synchronisation producer (Pr **MM.43**) and direct data mapping (Pr **MM.09**) are both enabled when SM-CANopen initialises, SM-CANopen will use a special operating mode for RxPDOA and TxPDOA. This special operating mode provides high speed deterministic data transfer for RxPDOA and TxPDOA data, ensuring that data received in RxPDOA is available for the POS0 task in the SM-Applications.

Direct data mapping uses Pr **MM.10** to Pr **MM.13** and Pr **MM.20** to Pr **MM.23** as target and source parameters. As they are 16-bit parameters, data compression (Pr **MM.34**) must be enabled.

SM-CANopen needs to access 9 parameters in less than 90µs for deterministic data transfer, and this can only be achieved by using fixed internal mappings to drive parameters with no range checking on the data values. This is achieved by using the mappings shown in Table 11.14

**Table 11.14 TxPDOA and RxPDOA data mappings**

TxPDOA data bytes	Source parameter		RxPDOA data bytes	Target parameter
0, 1	Pr <b>MM.10</b>		0, 1	Pr <b>MM.20</b>
2, 3	Pr <b>MM.11</b>		2, 3	Pr <b>MM.21</b>
4, 5	Pr <b>MM.12</b>		4, 5	Pr <b>MM.22</b>
6, 7	Pr <b>MM.13</b>		6, 7	Pr <b>MM.23</b>

The lack of range checking does not matter as each target and source drive parameter has the full 16-bit range. Meaning that the value of each pair of data bytes in RxPDOA can never exceed the range of the target parameter.

SM-CANopen will update the mapping objects for RxPDOA and TxPDOA in the CANopen object dictionary to reflect the actual mappings that are being used.

**Table 11.15 RxPDOA and TxPDOA (default TxPDO1) mapping objects**

Index	Sub-index	Mapping value <sup>XI</sup>	Target parameter
0x1600 - 0x17FF	0	0x04	
0x1600 - 0x17FF	1	0x20MM1410	Pr <b>MM.20</b>
0x1600 - 0x17FF	2	0x20MM1510	Pr <b>MM.21</b>
0x1600 - 0x17FF	3	0x20MM1610	Pr <b>MM.22</b>
0x1600 - 0x17FF	4	0x20MM1710	Pr <b>MM.23</b>
0x1A00 - 0x1BFF	0	0x04	
0x1A00 - 0x1BFF	1	0x20MM0A10	Pr <b>MM.10</b>
0x1A00 - 0x1BFF	2	0x20MM0B10	Pr <b>MM.11</b>
0x1A00 - 0x1BFF	3	0x20MM0C10	Pr <b>MM.12</b>
0x1A00 - 0x1BFF	4	0x20MM0D10	Pr <b>MM.13</b>

**NOTE**

The actual index will be determined by the values set in 0x2800 and 0x2801 i.e. the default PDO number -1.

As the mappings for RxPDOA and TxPDOA are fixed in direct access mode, changes made to these objects will NOT affect the actual mappings used by the SM-CANopen.

<sup>XI</sup> MM in the mapping value represents the hexadecimal equivalent of the slot menu, eg slot 1 (menu 15) would be MM = 0F.

## 11.14.4 Synchronisation status

Name	Synchronisation status	
Pr MM.44	Default	N/A
	Range	0 to 7
	Access	RO

Synchronisation status indicates the current synchronisation state of the SM-CANopen. Pr MM.44 is only updated when the SM-CANopen has been enabled as the synchronisation producer (see section 11.14.3 *Synchronisation modes* on page 91).

**Table 11.16 Synchronisation status**

Bit	Function	Description
1, 0	SYNC MODE	Indicates the current synchronisation mode selected in Pr MM.43
2	PRODUCER ACTIVE	SM-CANopen is currently active as the synchronisation producer for the drive
3	SYNC OK	Indicates that the jitter in the external signal being used to generate the DINT message is within tolerance for drive
4	SYNC QUALITY	The CANopen SYNC message is consistent. If the SYNC message stops or exceeds the maximum permitted jitter, SYNC QUALITY will be reset to 0.
5 to 7	RESERVED	Reserved

The timing accuracy of the SYNC message from the CANopen master controller is very important if the SM-CANopen is to maintain synchronisation. Refer to section 11.17.4 *Timing accuracy* on page 103 for further details.

## 11.14.5 Synchronisation period

Name	Synchronisation period	
Pr MM.45	Default	0
	Range	1, 2, 4 or 8
	Access	RW

The CANopen SYNC message must be produced every 1, 2, 4 or 8ms to allow the SM-CANopen to achieve synchronisation. The POS task in the SM-Applications must be configured to run at least once per CANopen SYNC message. (See Table 11.17.)

When SM-CANopen has synchronised with the CANopen network, Pr MM.45 shows the current synchronisation period in milliseconds. If synchronisation is lost for any reason, this value will be reset to 0.

**Table 11.17 Synchronisation timings**

CANopen SYNC rate	SM-Applications POS task (ms)					
	0.25	0.5	1	2	4	8
1	OK	OK	OK	-	-	-
2	OK	OK	OK	OK	-	-
4	OK	OK	OK	OK	OK	-
8	OK	OK	OK	OK	OK	OK

### 11.14.6 Synchronising Unidrive SP via the CANopen network

Synchronised position control allows a group of axes (drives) on a CANopen network to make their programmed position moves at the same time. This is very important in precision CNC machines, as the level of synchronisation between axes partly determines the “smoothness” of motion when following a curved profile.

Figure 11-4 and Table 11.18 describe each step of the process used to handle receipt and transmission of data and guarantee that all SM-CANopen devices respond at the same time.

**Table 11.18 CANopen timings**

Time	Description
t1	When RMINT_1MS occurs, SM-CANopen retrieves and writes RxPDOA data directly into Pr <b>MM.20</b> to Pr <b>MM.23</b> , updates the PDO counter in Pr <b>MM.46</b> then reads the values from Pr <b>MM.10</b> to Pr <b>MM.13</b> to generate TxPDOA. All parameter accesses are complete 70µs after RMINT_1MS occurred.
t2	The SM-Applications POS0 task will run 90µs after RMINT_POS. At this point, the new data values from RxPDOA are available to the DPL program in Pr <b>MM.20</b> to Pr <b>MM.23</b> and can be used to generate the new position reference for the advanced position controller. The advanced position controller will run immediately after POS0.
t3	The APC has completed, so the new speed reference will be available. This is transferred into the output channel by POS1, and the results of the APC calculations can be loaded into Pr <b>MM.10</b> to Pr <b>MM.13</b> for the next transmission of TxPDOA.
t4	The SM-Applications system will write the output channel value to the Unidrive SP hard speed reference (Pr <b>3.22</b> ) just before the POS0 task actually runs.
t5	The Unidrive SP speed loop will run on RMINT and will use the updated hard speed reference value in Pr <b>3.22</b> .

**NOTE** RxPDOA and TxPDOA is by default PDO1, but may be changed using objects 0x2801 and 0x2800.

### 11.15 Unidrive SP: position control without interpolation

Position reference interpolation is not required if the CANopen SYNC time (refer to section 11.14.5 *Synchronisation period* on page 93) is the same as the POS task time in the SM-Applications. The new position reference received from the CANopen master controller can be processed in the POS0 task and passed to the advanced position controller on each POS task cycle. Figure 11-5 *Position control without interpolation* on page 96 shows a synchronised CANopen system consisting of 4 nodes running at 1.0 Mbit/s and 1ms SYNC time. The SM-Applications POS0 task is also running at 1ms.

Figure 11-4 SM-CANopen timing

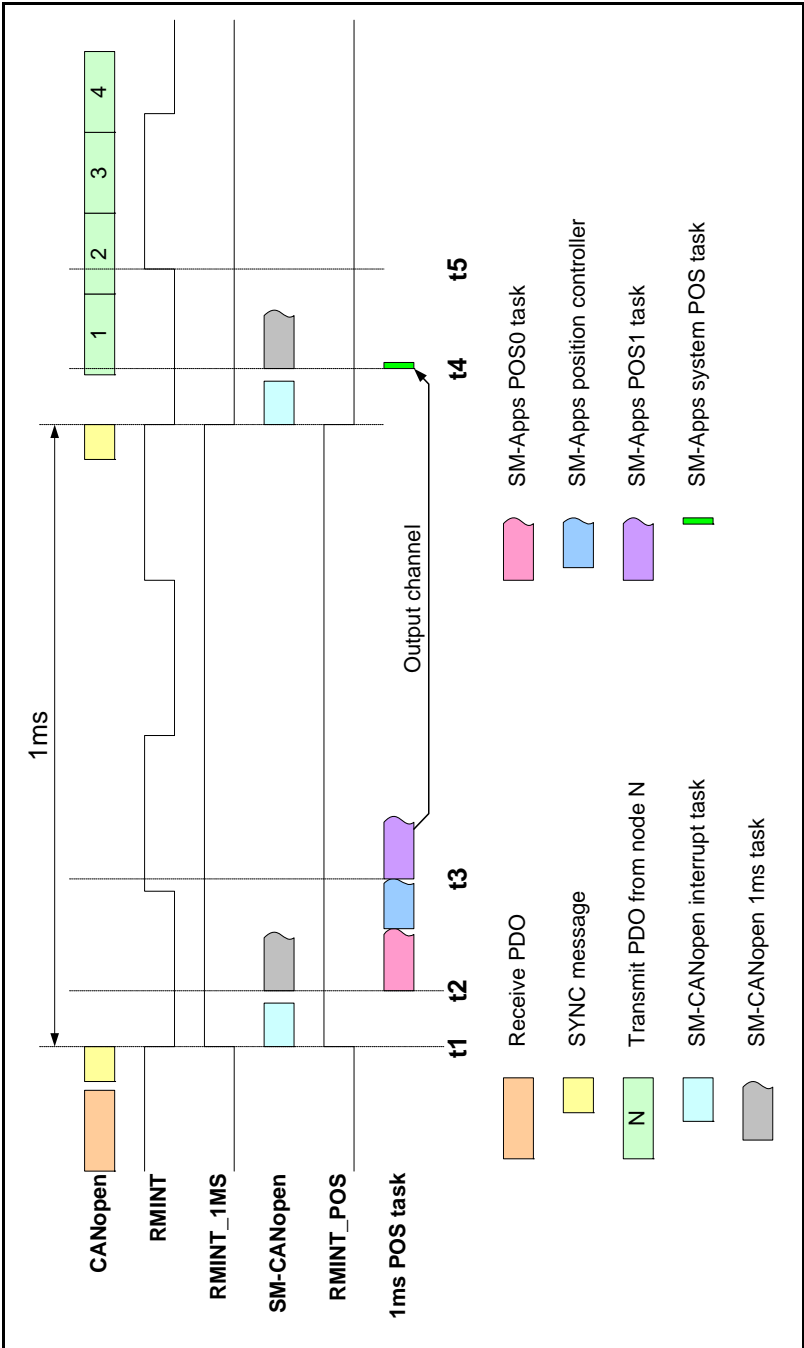
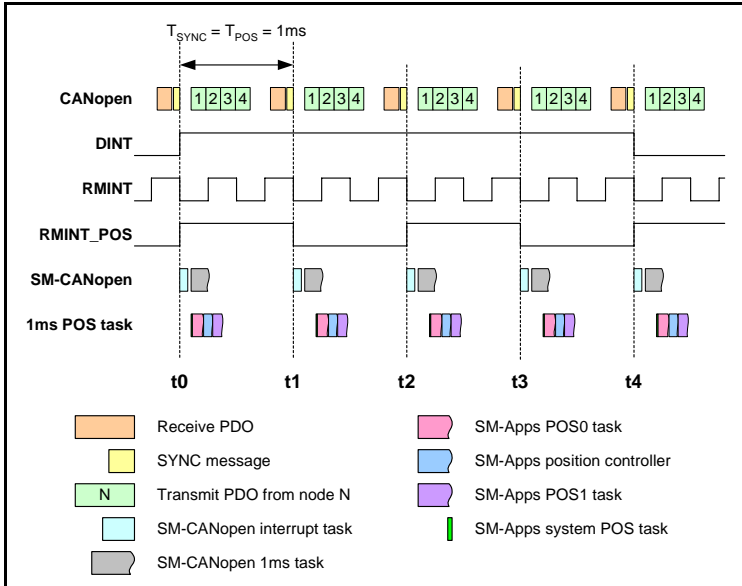
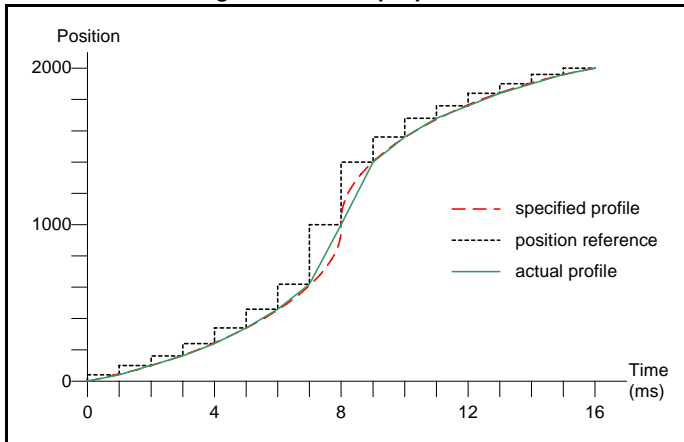

Figure 11-5 shows the effect that this has on the actual position loop.

**Figure 11-5 Position control without interpolation**



**Figure 11-6 Example profile 1**



# 11.16 Unidrive SP: position control with interpolation

Position reference interpolation is required if the synchronisation time (see Figure 11-8 *Uninterpolated position profile* on page 98) is different to the POS task time in the SM-Applications. Figure 11-7 *Position control with interpolation* shows a synchronised CANopen system consisting of 4 nodes running at 1.0 Mbit/s and 4ms SYNC time. The SM-Applications POS0 task is running at 1ms.

**Figure 11-7 Position control with interpolation**

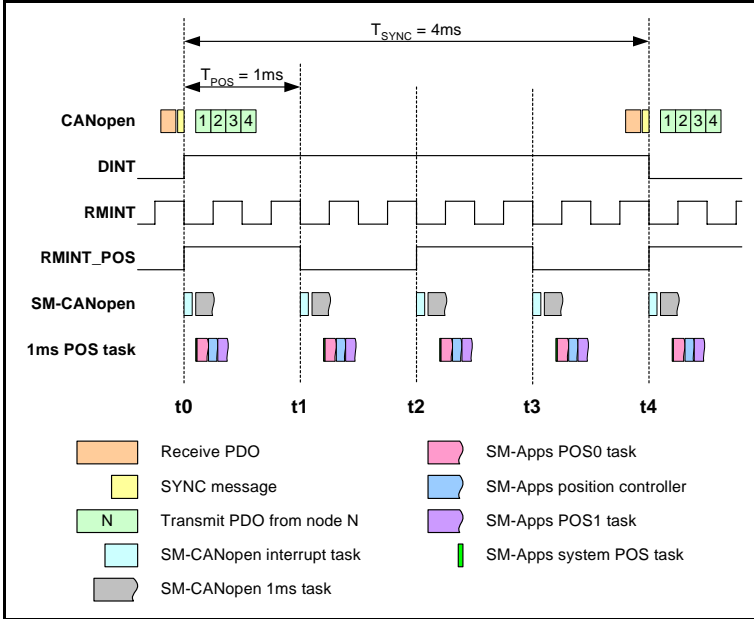

When the CANopen SYNC time is 4ms, the position reference received from the master controller is the target position that must be achieved 4ms later. If the SM-Applications position controller is running every 1ms, it will try to move to the new position in 1ms, instead of 4ms. The actual movement that will be produced is shown in section 11.14.5 *Synchronisation period* on page 93, and looks nothing like the specified profile.

Safety Information
Introduction
Mechanical Installation
Electrical Installation
Getting Started
EPS Files
Cyclic Data
Non-Cyclic Data
Control and Status Words
Diagnosics
Advanced Features
CANopen Reference
Quick Reference
Glossary Of Terms
Index

**Figure 11-8 Uninterpolated position profile**

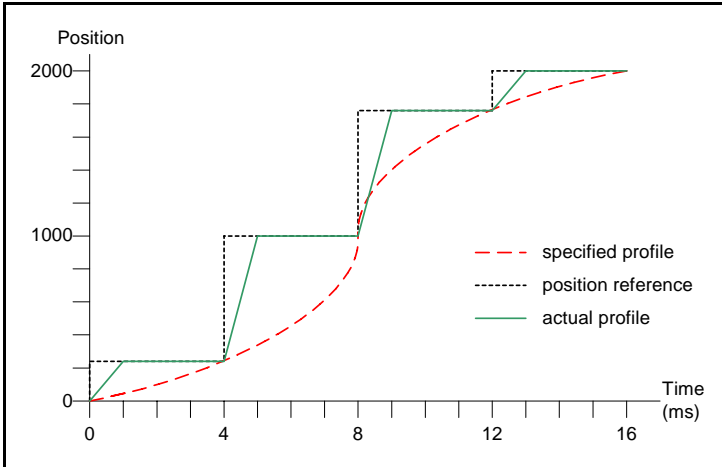

The solution is to use position reference interpolation. When a new position reference is received from the CANopen master controller, 3 intermediate step positions can be calculated and passed to the position controller on each 1ms cycle. This is shown in Figure 11-9 *Linear interpolation* where each interpolated position reference is a quarter of the position move required during the 4ms period.

**Figure 11-9 Linear interpolation**

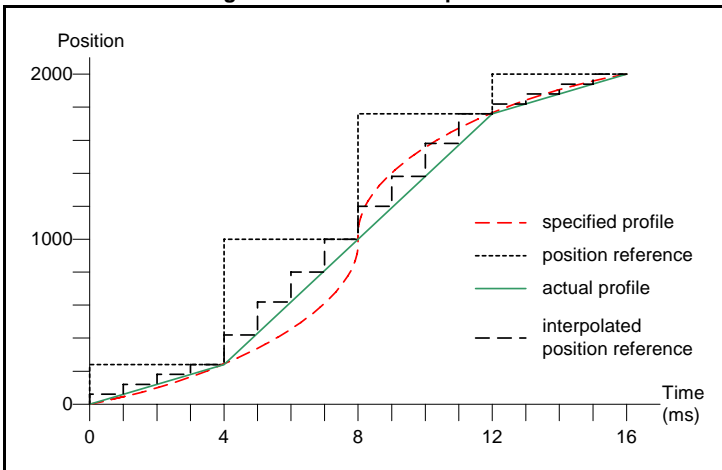

In all cases it is recommended that the maximum peak loading on the CANopen network does not exceed 70%. If this limit is exceeded reliable communication will be difficult to achieve.

If possible the master should be configured to transmit its PDOs immediately before the SYNC signal as this allows the drives to respond after the SYNC signal with reduced possibility for frame collisions and hence reduced network performance.

### 11.16.1 Timing and data transfer consistency

To achieve good results from the inter-module synchronisation scheme it is important to understand the timing constraints of this system.

The order of events during synchronised data transfer is as follows.

1. SYNC Message received from the CANopen network.
2. SM-CANopen toggles the DINT line to synchronise drive.
3. Received PDO data transferred from SM-CANopen to Pr **MM.20** to Pr **MM.23**.
4. Pr **MM.46** is incremented.
5. Data is transferred from Pr **MM.10** to Pr **MM.13** to SM-CANopen ready to be transmitted on the next CANopen SYNC period.

The transactions of data from network to drive are completed within 65us of the synchronisation message being received and are therefore within the 90us time slot allocated by the drive before the POS task begins to run. Should, however, the SYNC jitter on the network exceed +/-25us it is possible that the transactions will overrun and start to run concurrently with the POS task and its updating of values. This situation creates an inherent risk of data inconsistency within the PDO frame correlative to the amount of SYNC jitter on the network. To allow for the potential of SYNC jitter Pr **MM.46** should be utilised as a final check.

It is only when the entire RxPDO frame has been received, that the value in Pr **MM.46** is incremented, although values in the PDO frame may be available to be read by the SM-Applications prior to the completion of the transaction but without using Pr **MM.46** it is theoretically possible for incomplete data update to be read during the frames transmission and for data inconsistency to occur.

If strict network conditions are adhered to and data is only accessed by the SM-Applications module in the POS task after Pr **MM.46** has been incremented, any risk of data inconsistency is eliminated, as the entire frame is known to have been transmitted and its values updated. The user can test the value of Pr **MM.46** in the DPL by using a simple comparison thus:

```
if #15.46 <> the_old_value_15_46% then....
```

indicating the PDO has been received.

### 11.17 Synchronisation example

This example shows a scenario where the POS0 tasks of the modules in a Unidrive SP need to be synchronised with the CANopen network.

Table 11.19 on page 100 shows 2 SM-Applications modules synchronised to CANopen. Slot 1 has a 500us position task, Slot 2 has a 1ms position task and the CANopen network has a 2ms synchronisation period.

**Table 11.19 Parameter settings for synchronisation**

Slot	Parameter	Value	Description
<b>Slot1 SM-Applications</b>	Pr <b>MM.12</b>	2	500us task period
	#91.21	2	Inter-option Sync Consumer
	#91.22	6 (Read only)	Inter-option Sync Consumer status achieved.
<b>Slot2 SM-Applications</b>	Pr <b>MM.12</b>	3	1ms task period
	#91.21	2	Inter-option Sync Consumer
	#91.22	6 (Read only)	Inter-option Sync Consumer status achieved.
<b>Slot3 SM-CANopen</b>	Pr <b>MM.45</b>	2	2ms CANopen synchronisation
	Pr <b>MM.43</b>	1	Inter-option Sync Producer
	Pr <b>MM.44</b>	29 (Read only)	Inter-option Sync Producer status achieved (bits 0, 2, 3, and 4 set)

### 11.17.1 Internal interrupts

#### **RMINT, RMINT\_1MS and RMINT\_POS**

RMINT is a hardware interrupt within the Unidrive SP and is used to control the execution of the Unidrive SP speed loop. It is generated nominally every 250µs, but the internal phase-locked loop may be adjusted to synchronise to an external signal (see section 11.17.4 *Timing accuracy* on page 103 for more information). RMINT\_1MS is a software interrupt that is generated by SM-CANopen on every 4th RMINT to produce an internal 1ms task.

RMINT\_POS is also a software interrupt, and is generated by SM-Applications to produce the POS0 and POS1 tasks. The number of RMINT interrupts required to generate each RMINT\_POS is controlled by Pr **MM.12** allowing the timing of the POS tasks to be varied as required.

**NOTE** To guarantee synchronisation between SM-CANopen and SM-Applications on a Unidrive SP, the RMINT\_1MS and RMINT\_POS must be generated from the same RMINT interrupt. This is achieved by specifying SM-CANopen as the “synchronisation producer” and SM-Applications as the “synchronisation consumer”. SM-Applications will synchronise to the same RMINT as SM-CANopen and synchronisation between the modules is guaranteed.

**NOTE** The SM-Applications must be loaded with system file version 1.03.00 or later to guarantee synchronisation between RMINT\_1MS and RMINT\_POS.

Figure 11-10 shows the relationship between RMINT, RMINT\_1MS and RMINT\_POS, with Pr MM.12 set to 4 to produce the POS0 and POS1 tasks every 2ms.

**Figure 11-10 RMINT, RMINT\_1MS and RMINT\_POS**

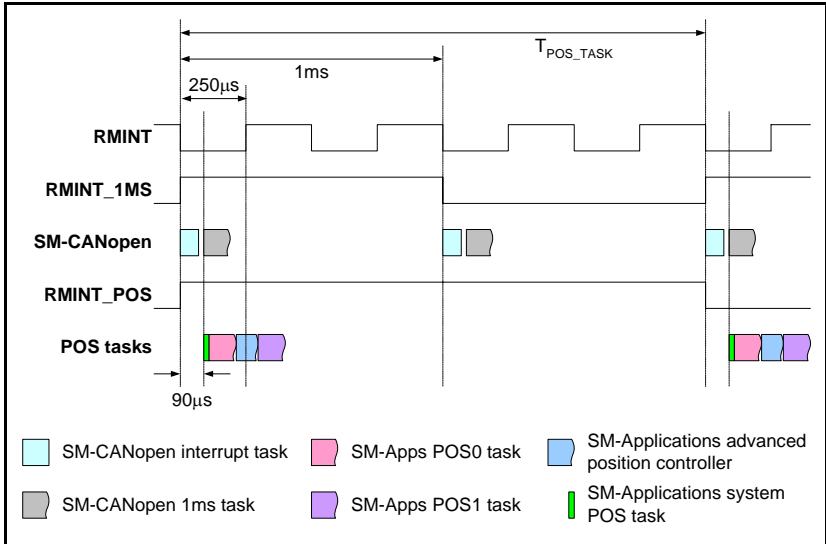

### 11.17.2 DINT

DINT is generated by the SM-CANopen when the SYNC message is received from the CANopen network. It is used by the Unidrive SP to determine the phase-locked loop adjustment required and this adjustment is applied when the next RMINT occurs. Any change of timing in RMINT will be seen on the 2nd RMINT after DINT occurred.

**Figure 11-11 DINT**

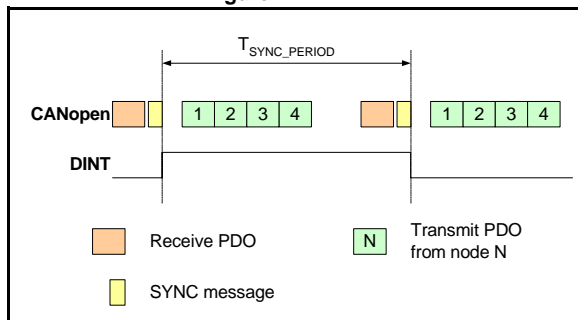

### 11.17.3 Output channel

The “output channel” provides a method of ensuring that the updated speed reference calculated by the advanced position controller is written to the target Unidrive SP parameter at a defined point with respect to RMINT\_POS. If RMINT\_POS is synchronised across all Unidrive SP on a system, all drives will receive and use the new speed reference at the same time. This ensures that all axes execute their programmed moves at the same time, giving higher accuracy when moving along a curved profile.

**Table 11.20 Output channel timing**

Time	Description
t1	SM-Applications 1 completes all position control calculations and transfers the data to the output channel.
t2	SM-Applications 2 completes all position control calculations and transfers the data to the output channel.
t3	The system POS task runs 90µs after RMINT_POS, and writes the data held in the output channel to the target parameter in the Unidrive SP.
t4	Unidrive SP will use the new speed reference when the speed loop runs on the next RMINT.

Figure 11-12 shows how the updated speed reference is written to 2 Unidrive SPs at the same time, despite the fact that the SM-Applications have different execution times for their POS0 and POS1 tasks.

If the output channel was not used, Unidrive SP 2 would use the new speed reference on the next RMINT when compared to Unidrive SP 1.

**Figure 11-12 Output channel**

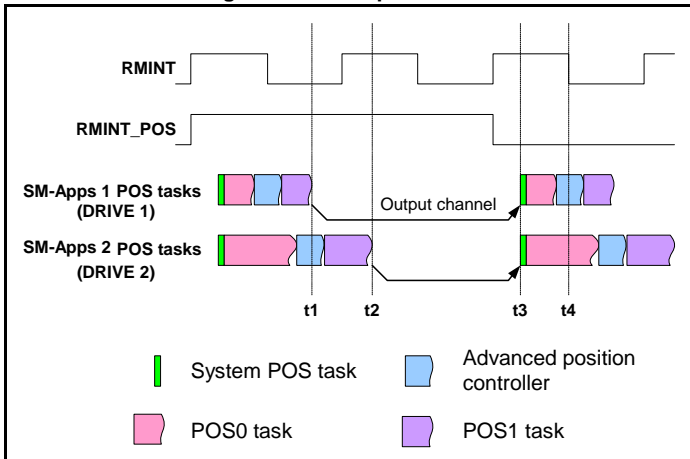

## 11.17.4 Timing accuracy

Table 11.21 shows the timing specifications for a synchronised CANopen network.

**Table 11.21 Synchronised CANopen specifications**

Function	Range	Description
Master SYNC accuracy	+/- 0.4%	The maximum range in the nominal SYNC time produced by the CANopen master for SM-CANopen to maintain synchronisation.
Master SYNC jitter	25µs max	The maximum permitted jitter in the SYNC message for SM-CANopen to maintain synchronisation.
Slave RMINT jitter	+/-2µs	The maximum jitter in the RMINT interrupts between any 2 Unidrive SPs synchronised using SM-CANopen.

## 11.17.5 SYNC absolute timing accuracy

The Unidrive SP phase-locked loop generates RMINT nominally every 250µs, but this can be adjusted by +/-1µs to compensate for small differences in crystal clock frequencies between different devices. RMINT cannot be adjusted outside of this limit, so this gives a maximum adjustment of 1µs for every 250µs, i.e. 0.4%. The CANopen master must be able to produce the SYNC message nominally every 1, 2, 4 or 8ms, accurate to +/-0.4%.

If the CANopen master is configured to produce the SYNC message every 1ms, but actually produces it every 1.002ms, this equates to an error of 0.2% so will not cause a problem. SM-CANopen will synchronise to the SYNC message and adjust the timing of the Unidrive SP phase-locked loop to generate RMINT every 250.5µs. The 1ms tasks in SM-CANopen and SM-Applications will now run every 1.002ms, and remain fully synchronised with the CANopen master.

## 11.17.6 SYNC jitter

“Jitter” is the term used for timing variations seen in a signal, but these timing variations will always average out to 0 over a period of time. “SYNC jitter” is the continuous variation in the actual timing between SYNC messages. SM-CANopen can handle “SYNC jitter” of +/- 25µs without losing synchronisation.

If the CANopen master is producing the SYNC messages nominally every 1.002ms with 20ms jitter, the timing between SYNC messages will range from 1.982 to 1.022ms. However, over a period of time, jitter will cancel out, and the average SYNC message time seen by SM-CANopen will be 1.002ms.

**NOTE** Please refer to Pr **MM.46 (11.16.1 Timing and data transfer consistency on page 99)**.

Safety Information
Introduction
Mechanical Installation
Electrical Installation
Getting Started
EPS Files
Cyclic Data
Non-Cyclic Data
Control and Status Words
Diagnostics
Advanced Features
CANopen Reference
Quick Reference
Glossary Of Terms
Index

### 11.17.7 Slave RMINT accuracy

The accuracy of the synchronisation process using SM-CANopen is quoted as the maximum jitter that will be seen between the RMINT signals of any 2 Unidrive SPs on the CANopen network.

Maximum RMINT jitter = +/- 2µs

As the Unidrive SP speed loop runs every 250µs, the maximum synchronisation jitter BETWEEN ANY 2 DRIVES equates to 0.8% across the CANopen network.

Figure 11-13 shows how the timings of RMINT may vary between 4 Unidrive SPs across a network, but the difference between any 2 RMINT signals will not exceed +/-2µs.

Figure 11-13

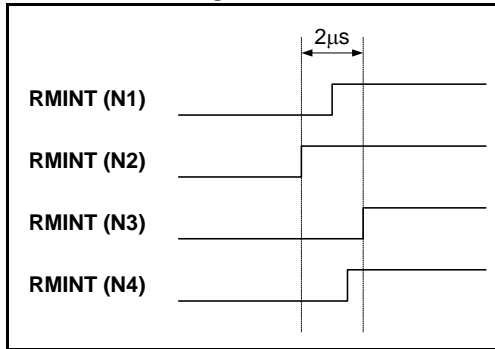

In this case, the worst case delay between RMINTs is between node 2 and node 3. The difference between any other pair of nodes is always less than 2µs.

### 11.17.8 Network load

The network load determines the fastest update time that can be achieved for a given CANopen network. Network load depends on the network data rate, CANopen SYNC rate, total number of devices on the network and amount of data for each device.

If the load factor (see equations below) is < 0.85, the required performance can normally be achieved with an error-free CANopen network.

$$\text{Load factor} = \frac{100 + [(47 + \sum N_{\text{PDOBits}}) \times T_{\text{Bit}}]}{T_{\text{Sync}} \times 1000}$$

$$N_{\text{PDOBits}} = 47 + (8 \times N_{\text{Bytes}})$$

where:

$T_{\text{Bit}}$  = bit time in microseconds (see Table 11.22)

$T_{\text{Sync}}$  = SYNC message time in milliseconds.

$N_{\text{PDOBits}}$  = number of bits in each TxPDO or RxPDO that will be transmitted.

$N_{\text{Bytes}}$  = number of data bytes (0 to 8) for the RxPDO or TxPDO.

**Table 11.22 CANopen timings**

Data rate	T <sub>Bit</sub> (μS)		Data rate	T <sub>Bit</sub> (μS)
1.0M	1		100K	10
800K	1.25		50K	20
500K	2		20K	50
250K	4		10K	100
125K	8			

Safety Information
Introduction
Mechanical Installation
Electrical Installation
Getting Started
EDS Files
Cyclic Data
Non-Cyclic Data
Control and Status Words
Diagnostics
<b>Advanced Features</b>
CANopen Reference
Quick Reference
Glossary Of Terms
Index

---

## 12 CANopen Reference

---

### CANopen object dictionary

The CANopen Object Dictionary defines a series of objects that contain data values with which to configure SM-CANopen.

#### 12.1 Communication profile objects supported

Quick reference links to all communication object sections can be found in Chapter 13 *Quick Reference* on page 154.

**Table 12.1 Profile objects**

Index	Name	PDO mapping
0x1000	<i>Device Type</i>	No
0x1001	<i>Error register</i>	No
0x1002	<i>Manufacturer Status Register</i>	No
0x1003	<i>Pre-defined Error Field</i>	No
0x1005	<i>COB-ID SYNC</i>	No
0x1008	<i>Manufacturer Device Name</i>	No
0x1009	<i>Manufacturer Hardware Version</i>	No
0x100A	<i>Manufacturer Software Version</i>	No
0x1010*	<i>Store parameters</i>	No
0x1011*	<i>Restore default parameters</i>	No
0x1014	<i>COB-ID EMCY</i>	No
0x1017	<i>Producer Heartbeat Time</i>	No
0x1018	<i>Identity Object</i>	No
0x1400 0x15FF	<i>Communication Information for RxPDO</i>	No
0x1600 0x17FF	<i>Mapping Information for RxPDO</i>	No
0x1800 0x19FF	<i>Communication Information for TxPDO</i>	No
0x1A00 0x1BFF	<i>Mapping Information for TxPDO</i>	No
0x2800	<i>RxPDO number configuration</i>	No
0x2801	<i>TxPDO number configuration</i>	No

**NOTE** \* Not available with commander SX.

#### 12.2 Basic data types

These are basic data types and are available in order to facilitate the need to set mappings to parameters of null values (i.e. when creating blank mappings). 'In' mappings or TxPDOs to these objects will return 0. An 'out' mapping or RxPDO will reference a null object of predefined size.

For example if only a single 16 bit word is used within a PDO the remaining words that are unused within the particular drive should be mapped to a null data type of the appropriate size.

**Table 12.2 Basic data types**

Index	Name	Size
0x0002	Integer8	8
0x0003	Integer16	16
0x0004	Integer32	32
0x0005	Unsigned8	8
0x0006	Unsigned16	16
0x0007	Unsigned32	32

## 12.3 Device type

<b>Index</b>	0x1000	<b>Sub-index</b>	0	<b>Access</b>	RO
<b>Default</b>	N/A	<b>Data type</b>	UNSIGNED32	<b>Object code</b>	VAR

**device type** indicates the current configuration of the drive and SM-CANopen and is used by some CANopen master controllers to ensure that the correct EDS file is being used.

**Table 12.3 Device type**

Additional information		Device profile number
Mode	Type	
b31-b24 Refer to Table 12.5	b23-b16 Refer to Table 12.4	b15-b0 Refer to Table 12.4

**device type** is constructed using the values as indicated in Table 12.4 and Table 12.5.

**Table 12.4 Device profile number and type**

Type	Device profile number	Description
0x00	0x0000	All device profiles are disabled
0x01	0x0192	Device profile DS402 V1.1 enabled, drive is running in Servo, open loop or regen mode (see section 12.15.1 <i>Enable DSP402 device profiles</i> on page 137).
0x03	0x0192	Device profile DS402 V1.1 enabled, drive is running in closed loop or servo mode (see section 12.15.1 <i>Enable DSP402 device profiles</i> on page 137).

The mode byte is manufacturer-specific and is specified in Table 12.5.

**Table 12.5 Mode Bytes**

Mode	Setting	Description
b26-b24	Drive mode	Indicates the operating mode of the drive. 0 = SE mode (000) 1 = open loop (001) 2 = closed loop (010) 3 = servo (011) 4 = regen (111)
b27	Data compression enabled	Set to 1 if data compression (Pr <b>MM.34</b> ) is enabled. This affects the data size used by drive parameters, so a different EDS file must be used.
b28	SM-Applications fitted	Set to 1 if an SM-Applications is fitted to the drive.
b31-b29	Reserved	Reserved.

### 12.3.1 Error register

Index	0x1001	Sub-index	0	Access	RO
Default	N/A	Data type	UNSIGNED8	Object code	VAR

The **error register** is used by SM-CANopen to indicate that an error has occurred. If a bit is set to 1, the specified error has occurred. The **error register** is part of the emergency object, refer to section 12.13 *Emergency object* on page 134 for further details.

**Table 12.6 Error register bits**

Bit	Error
0	Generic error
1	Current
2	Voltage
3	Temperature
4	Communication error
5	Device profile specific
6	Reserved
7	Manufacturer specific

### 12.3.2 Manufacturer status register

Index	0x1002	Sub-index	0	Access	RO
Default	N/A	Data type	UNSIGNED32	Object code	VAR

The **manufacturer status register** is mapped directly to the status word (Pr **10.40**) in the drive. See section 9.3 *Status word* on page 68 for more details about the drive status word.

### 12.3.3 Pre-defined error field

Index	0x1003
Object code	ARRAY
Data type	UNSIGNED32

The **pre-defined error field** returns 32-bit error code containing data from the last 4 emergency messages that were sent. If less than 4 emergency objects have been sent, the higher sub-indexes will not exist.

**Table 12.7 pre-defined error field**

Byte 3	Byte 2	Byte 1	Byte 0
SM-CANopen error code (Pr MM.50)	Drive trip code (Pr 10.20)	Emergency object error code	

**number of errors**

Index	0x1003	Sub-index	0	Access	RO
Default	4	Data type	UNSIGNED8	Object code	VAR

Sub-index 0 is an unsigned8 data type which indicates the highest sub-index for the **pre-defined error field**. The rest of the array are unsigned32 data types.

**error field 1**

Index	0x1003	Sub-index	1	Access	RO
Default	N/A	Data type	UNSIGNED32	Object code	VAR

Returns the last emergency object codes.

**error field 2**

Index	0x1003	Sub-index	2	Access	RO
Default	N/A	Data type	UNSIGNED32	Object code	VAR

Returns the 2nd last emergency object codes.

**error field 3**

Index	0x1003	Sub-index	3	Access	RO
Default	N/A	Data type	UNSIGNED32	Object code	VAR

Returns the 3rd last emergency object codes.

**error field 4**

Index	0x1003	Sub-index	4	Access	RO
Default	N/A	Data type	UNSIGNED32	Object code	VAR

Returns the 4th last emergency object codes.

**12.3.4 COB-ID SYNC**

Index	0x1005	Sub-index	0	Access	RW
Default	0x00000080	Data type	UNSIGNED32	Object code	VAR

**COB-ID SYNC** defines the COB-ID that will be used for the synchronisation (SYNC) object. The SM-CANopen receives the SYNC message, but it cannot be used to generate the SYNC object.

b31	b30	b29	b28 - b11	b10 - b0
0	0	0	0000000000000000	11-bit CAN-ID

The upper 3 bits (b31-b29) are used to specify the SYNC behaviour of SM-CANopen.

**Table 12.8 COB-ID SYNC configuration**

Bit	Value	Comment
31	0	Reserved.
30	0	SM-CANopen consumes the SYNC message.
29	0	11-bit CAN identifier.

Refer to section 12.6.3 *RxPDO transmission type* on page 118 and section 12.8.3 *TxPDO transmission type* on page 122 for details of the transmission types that use the SYNC object.

### 12.3.5 Manufacturer device name

Index	0x1008	Sub-index	0	Access	CONST
Default	SM-CANopen	Data type	STRING	Object code	VAR

Returns the string “SM-CANopen” to indicate the product name.

### 12.3.6 Manufacturer hardware version

Index	0x1009	Sub-index	0	Access	CONST
Default	UT77	Data type	STRING	Object code	VAR

Returns the string “UT77” to indicate the product hardware.

### 12.3.7 Manufacturer software version

Index	0x100A	Sub-index	0	Access	CONST
Default		Data type	STRING	Object code	VAR

Returns a string to indicate the firmware version installed. The string will be formatted as “Vxxyyz” where xxyy is the major firmware version and zz is the minor firmware version.

### 12.3.8 Store parameters

This object (0x1010\*) supports the saving of parameters in non-volatile memory.

**Table 12.9 Object 0x1010**

Index	Sub-index	Description
0x1010	0	Will return 1 when read to indicate that the “save all parameters” option is supported.
0x1010	1	Will return 1 when read to indicate that the module can save parameters. Writing the save signature of 0x65766173 will cause the following actions. #60.31 = 1 Set the module to save its set-up to flash. #60.00 = 1000 Set the drive to save its parameters. #10.38 = 100 Reset the drive to perform the save.

The module reset that follows the parameter save will be inhibited to prevent loss of communications. It is recommended that this procedure is done once during commissioning.

**NOTE** \* Not available with commander SX.

### 12.3.9 Restore default parameters

With this object (0x1011\*) the default values of parameters according to the communication or device profile are restored.

**Table 12.10 Object 0x1011**

Index	Sub-index	Description
0x1011	0	Will return 1 when read to indicate that the "restore default parameters" option is supported.
0x1011	1	Will return 1 when read to indicate that the module can restore parameters. Writing the save signature of 0x64616F6C will cause the following actions. #60.30 = 1 Set the module to restore its defaults. #60.00 = #11.46 Set the drive to restore its previous defaults (automatically converted on SK). #10.38 = 100 Reset the drive to perform the save.

The module reset that follows the parameter save will be inhibited to prevent loss of communications. This will allow the communication parameters to be configured prior to a reset.

**NOTE** \* Not available with commander SX.

### Stored objects

The following objects will always be stored in internal flash.

- 0x1005 – COB-ID SYNC
- 0x1014 – COB-ID EMCY
- 0x1017 – Producer Heartbeat time
- 0x2800 – RxPDO number configuration
- 0x2801 – TxPDO number configuration
- 0x1400 - 0x1BFF – PDO configuration objects

The following objects will only be stored in internal flash if Pr **MM.42** is 0.

- 0x6042 – vl\_target\_velocity
- 0x6044 – vl\_control\_effort
- 0x6046 – vl\_velocity\_min\_max\_amount
- 0x6048 – vl\_velocity\_acceleration
- 0x6049 – vl\_velocity\_deceleration
- 0x604C – vl\_dimension\_factor
- 0x605A – quick\_stop\_option\_code
- 0x605B – shut\_down\_option\_code
- 0x605C – disable\_operation\_option\_code
- 0x6060 – modes\_of\_operation
- 0x6071 – target\_torque
- 0x6087 – torque\_slope
- 0x6088 – torque\_profile\_type

Safety Information
Introduction
Mechanical Installation
Electrical Installation
Getting Started
EPS Files
Cyclic Data
Non-Cyclic Data
Control and Status Words
Diagnostics
Advanced Features
CANopen Reference
Quick Reference
Glossary Of Terms
Index

Objects defined by object association in an SM-Applications module will not get saved in internal flash due to the time required to discover available objects and the space that would be required to store the potentially large number of objects. If these objects need saving then it will be the responsibility of the user program to ensure they are stored.

### 12.3.10 COB-ID EMCY

<b>Index</b>	0x1014	<b>Sub-index</b>	0	<b>Access</b>	RW
<b>Default</b>	0x00000080 + node address	<b>Data type</b>	UNSIGNED32	<b>Object code</b>	VAR

**COB-ID EMCY** defines the COB-ID to be used for the emergency object.

<b>b31</b>	<b>b30</b>	<b>b29</b>	<b>b28 - b11</b>	<b>b10 - b0</b>
0	0	0	0000000000000000	11-bit ID

The upper 3 bits (b31-b29) are used to specify the emergency object behaviour of SM-CANopen.

**Table 12.11 COB-ID SYNC configuration**

Bit	Value	Comment
31	0	EMERGENCY object always exists
30	0	Reserved
29	0	11-bit CAN identifier

Refer to section 12.13 *Emergency object* on page 134 for full details about the emergency object.

### 12.3.11 Producer heartbeat time

<b>Index</b>	0x1017	<b>Sub-index</b>	0	<b>Access</b>	RW
<b>Default</b>	0	<b>Data type</b>	UNSIGNED16	<b>Object code</b>	VAR

The “heartbeat protocol” is a node protection system or error control service. A “heartbeat producer” is usually a CANopen slave device which transmits a heartbeat message cyclically. This message is received by a one or more “heartbeat consumer” devices, usually the CANopen master controller, and indicates to the master controller that the slave device is communicating successfully.

If the heartbeat message is not received within the defined time period, a “heartbeat event” will be generated in the master controller, allowing it to take appropriate action to ensure system safety is maintained.

The producer heartbeat time defines the cyclic time period (in milliseconds) for SM-CANopen to transmit the heartbeat message. A value of 0 disables the heartbeat message. The heartbeat message also includes the current NMT state of the SM-CANopen.

**Table 12.12 SM-CANopen operating states**

State	Operating state
0	BOOTUP
4	STOPPED
5	OPERATIONAL
127	PRE-OPERATIONAL

The SM-CANopen will start transmitting the heartbeat message as soon as it is enabled. If the **producer heartbeat time** is set >0 at power up, SM-CANopen will start transmitting the heartbeat message when the transition from BOOTUP to PRE-OPERATIONAL occurs. In this case, the boot-up message is regarded as the first heartbeat message.

### 12.3.12 Identity object

<b>Index</b>	0x1018
<b>Object code</b>	RECORD
<b>Data type</b>	UNSIGNED32

Identity object returns general information about the SM-CANopen.

#### Number of entries

<b>Index</b>	0x1018	<b>Sub-index</b>	0	<b>Access</b>	RO
<b>Default</b>	4	<b>Data type</b>	UNSIGNED8		

Returns the highest sub-index available for the identity object.

#### Vendor ID

<b>Index</b>	0x1018	<b>Sub-index</b>	1	<b>Access</b>	RO
<b>Default</b>	0xF9	<b>Data type</b>	UNSIGNED32		

Returns the CANopen vendor ID (0xF9) for Control Techniques.

#### Product code

<b>Index</b>	0x1018	<b>Sub-index</b>	2	<b>Access</b>	RO
<b>Default</b>	408	<b>Data type</b>	UNSIGNED32		

Returns the SM-CANopen module ID code of 408 (refer to section 10.3 *SM-CANopen node address* on page 71).

#### Revision number

<b>Index</b>	0x1018	<b>Sub-index</b>	3	<b>Access</b>	RO
<b>Default</b>	N/A	<b>Data type</b>	UNSIGNED32		

Returns the SM-CANopen firmware version. **Revision number** will consist of the Pr **MM.02** in the high data word, and Pr **MM.51** in the low data word (see section 10.3 *SM-CANopen node address* on page 71).

**Table 12.13 Revision number**

<b>Major revision (b31 - b16)</b>	<b>Minor revision (b15 - b0)</b>
Pr <b>MM.02</b>	Pr <b>MM.51</b>

#### Serial number

<b>Index</b>	0x1018	<b>Sub-index</b>	4	<b>Access</b>	RO
<b>Default</b>	N/A	<b>Data type</b>	UNSIGNED32		

Returns the SM-CANopen serial number, also available as Pr **61.35**. This value is programmed during manufacture and cannot be changed.

## 12.4 Flexible PDO numbering (0x2800 and 0x2801)

This functionality is supported from Version 02.01.00 onwards. The behaviour of the PDO configuration objects will be changed in order to conform to the CANopen specification, whilst still offering as much flexibility as possible. There are 4 Tx and 4 Rx PDOs available in the module, these PDOs will be referred to as PDOs A, B, C and D. Each of these PDOs can be configured to be any of the 512 available PDOs, by default the configuration will be PDOA = 1, PDOB = 3, PDOC = 5 and PDOD = 6 (for both TxPDOs and RxPDOs). The configuration of available PDOs will be possible through 2 new manufacturer specific objects accessible by the SDOs, namely objects 0x2800 and 0x2801 which manipulate the RxPDOs and TxPDOs respectively.

If a configuration using non-default or flexible numbering is required, the index number for the PDO communication objects must be derived by subtracting 1 from the PDO number and adding this number to the base address e.g. for 0x1600 PDO3 = 0x1602 (mapping information for RxPDOs).

**Table 12.14 PDO Number Changes**

PDO Details		Object to Change	
PDO	PDO Default	Index	Sub-index
RxPDOA	RxPDO1	2800	01
RxPDOB	RxPDO3	2800	02
RxPDOC	RxPDO5	2800	03
RxPDOD	RxPDO6	2800	04
TxPDOA	TxPDO1	2801	01
TxPDOB	TxPDO3	2801	02
TxPDOC	TxPDO5	2801	03
TxPDOD	TxPDO6	2801	04

**NOTE** The PDO number written to these objects is the required PDO number - 1.

## 12.5 Mapping parameter values

When setting up cyclic data to contain specific parameters this may be done in two ways:

1. The first method is to use the mapping parameters Pr **MM.10** - Pr **MM.13** and Pr **MM.20** - Pr **MM.23**.
2. The second is to use SDOs to set the mappings. When this is done the entries take the following form:

b31 – b16	b15 – b8	b7 – b0
Index	Sub-index	Object length (in bits)

These are used with object 0x1600 - 0x17FF and object 0x1A00 - 0x1BFF for RxPDO and TxPDO mapping respectively. To map RxPDOA(1) to Pr 1.21, the mapping parameter would be set to 0x20011520 (index = 0x2001, sub-index = 0x15, object length = 0x20, i.e. 32 bits).

Refer to section 8.1 *Service data object (SDO) parameter access* on page 54 for more details on how to access drive parameters.

## 12.5.1 RxPDO number configuration

This object will be used for configuring the available RxPDOs.

<b>Index</b>	0x2800	<b>Sub-index</b>	0	<b>Access</b>	RO
Largest sub-index supported		Value = 4			

<b>Index</b>	0x2800	<b>Sub-index</b>	1	<b>Access</b>	RW
PDO number for RxPDO A*		Range 0 to 511			

<b>Index</b>	0x2800	<b>Sub-index</b>	2	<b>Access</b>	RW
PDO number for RxPDO B*		Range 0 to 511			

<b>Index</b>	0x2800	<b>Sub-index</b>	3	<b>Access</b>	RW
PDO number for RxPDO C*		Range 0 to 511			

<b>Index</b>	0x2800	<b>Sub-index</b>	4	<b>Access</b>	RW
PDO number for RxPDO D*		Range 0 to 511			

Index	Sub-index	Description
0x2800	0	Will return 4 when read indicating the maximum sub-index and number of PDOs supported.
0x2800	1- 4	Are used to read and set the RxPDO number for each of the 4 configurable RxPDOs. The number is specified as required number less 1. That is PDO1 would be represented as 0.

**NOTE** \* The actual index number is calculated by subtracting 1 from the PDO number and adding this number to the base address e.g. for 0x1600 PDO3 = 0x1602.

## 12.5.2 TxPDO number configuration

This object will be used for configuring the available TxPDOs.

<b>Index</b>	0x2801	<b>Sub-index</b>	0	<b>Access</b>	RO
Largest sub-index supported		Value = 4			

<b>Index</b>	0x2801	<b>Sub-index</b>	1	<b>Access</b>	RW
PDO number for TxPDO A*		Range 0 to 511			

<b>Index</b>	0x2801	<b>Sub-index</b>	2	<b>Access</b>	RW
PDO number for TxPDO B*		Range 0 to 511			

<b>Index</b>	0x2801	<b>Sub-index</b>	3	<b>Access</b>	RW
PDO number for TxPDO C*		Range 0 to 511			

<b>Index</b>	0x2801	<b>Sub-index</b>	4	<b>Access</b>	RW
PDO number for TxPDO D*		Range 0 to 511			

Index	Sub-index	Description
0x2801	0	Will return 4 when read indicating the maximum sub-index and number of PDOs supported.
0x2801	1- 4	Are used to read and set the TxPDO number for each of the 4 configurable TxPDOs. The number is specified as required number less 1. That is PDO1 would be represented as 0.

**NOTE** \* The actual index number is calculated by subtracting 1 from the PDO number and adding this number to the base address e.g. for 0x1600 PDO3 = 0x1602.

**NOTE** Any modifications to the configuration of PDO A carried out over the SDO protocol will result in the mode parameter Pr **MM.05** being set to 300. This will be used to indicate that the configuration in the set-up menu is not currently being used.

The Download To Module Pr **MM.31** routine has been updated to store all suitable objects from the communication and profile area of the object dictionary. If the SM-Applications Object Priority parameter Pr **MM.42** is set, the objects in the profile area will not get saved. When the option module is defaulted the stored objects will be erased.

At start-up, the module will load values that have been stored in its internal flash into the object dictionary. Values for PDO A configuration objects will only be loaded if Pr **MM.05** is set to 300. If there are no values stored in flash and Pr **MM.05** is set to 300 then PDO A will be left in defaults. Please refer to Pr **MM.05** in **section 5-10 SDO Configuration** on page 39.

### 12.5.3 Communication information for RxPDO

This section contains the communication parameters for the receive PDOs.

<b>Index</b>	0x1400-0x15FF	<b>Sub-index</b>	0	<b>Access</b>	RO
Largest sub-index supported		Size			

<b>Index</b>	0x1400-0x15FF	<b>Sub-index</b>	1	<b>Access</b>	RO
COB-ID used by PDO		Size			

<b>Index</b>	0x1400-0x15FF	<b>Sub-index</b>	2	<b>Access</b>	RW
Transmission type		Size			

<b>Index</b>	0x1400-0x15FF	<b>Sub-index</b>	3	<b>Access</b>	RW
Inhibit time (not used for RxPDO)		Size			

<b>Index</b>	0x1400-0x15FF	<b>Sub-index</b>	4	<b>Access</b>	RW
Compatibility entry		Size			

<b>Index</b>	0x1400-0x15FF	<b>Sub-index</b>	5	<b>Access</b>	RW
Event timer		Size			

## 12.6 RxPDO communication parameters

<b>Index</b>	0x1400-0x15FF
<b>Object code</b>	Record
<b>Data type</b>	PDOCommPar

This section contains the communication parameters for the RxPDOs. SM-CANopen supports a total of 4 RxPDOs. Each PDO has a main index assigned to it, with individual parameters for the PDO accessed using sub-indices.

**Table 12.15 Supported RxPDOs**

RxPDO	Index
A	0x1400-0x15FF
B	0x1400-0x15FF
C	0x1400-0x15FF
D	0x1400-0x15FF

All RxPDO configuration parameters are dynamic (any changes made to these parameters will take effect immediately).

### 12.6.1 Number of entries

<b>Index</b>	0x1400-0x15FF	<b>Sub-index</b>	0
<b>Data type</b>	UNSIGNED8	<b>Access</b>	RO

Defines the largest sub-index supported for the specified RxPDO.

**Table 12.16 RxPDO number of entries**

RxPDO	Index	Value
A	0x1400-0x15FF	5
B	0x1400-0x15FF	5
C	0x1400-0x15FF	5
D	0x1400-0x15FF	5

**NOTE** Where the range for the index is determined by the PDO numbers set in object 0x2800.

### 12.6.2 RxPDO COB-ID

<b>Index</b>	0x1400-0x15FF	<b>Sub-index</b>	1
<b>Data type</b>	UNSIGNED32	<b>Access</b>	RW

The COB-ID is the CAN identifier used by the CANopen master controller to send RxPDO messages over the CANopen network. The COB-ID is usually calculated using the target slave node address, allowing each node to determine which RxPDO message it should use.

RxPDO COB-IDs do not have to be unique in slave devices on a CANopen network, as they can only originate from the CANopen master controller. It is common for a master controller to send a single RxPDO message containing 4 different speed or position references and have 4 different slave nodes configured to receive the same RxPDO. Each node simply extracts the reference it requires and discards the remaining data.

This makes efficient use of the available bandwidth of the CANopen network, as a single message is used to update 4 slave devices with new speed or position references, instead of 4 messages.

b31	b30	b29	b28 - b11	b10 - b0
RxPDO Disable	RTR Disable	29-bit ID Enable	0000000000000000	11-bit ID

The upper 3 bits (b31-b29) are used to enable certain functions of the RxPDO.

**Table 12.17 RxPDO COB-ID configuration**

Function	Comment
PDO Disable	Set to 1 to disable the PDO. SM-CANopen will ignore any messages that are received with the specified 11-bit ID
RTR Disable	Set to 1 to disable RTR with the PDO
29-bit ID Enable	SM-CANopen hardware does not support 29-bit CAN identifiers. so this bit must always be 0

DSP301 V4.1 specifies default COB-ID values for RxPDO1 to RxPDO4, while all higher RxPDOS must be disabled by default. Default values for the RxPDO COB-IDs are shown in Table 12.18.

**Table 12.18 RxPDO COB-ID default values**

PDO	Index	Default COB-ID
1	0x1400	0x80000200 + node address.
2	0x1402	0x80000300 + node address.
3	0x1404	0x80000400+ node address.
4	0x1405	0x80000500+ node address.

**NOTE** RxPDO numbers above 4 are defaulted to 0x80000000.

### 12.6.3 RxPDO transmission type

Index	0x1400-0x15FF	Sub-index	2
Data type	UNSIGNED8	Access	RW

The transmission type defines when data received in an RxPDO is processed and passed though to the target parameters. SM-CANopen supports all CANopen transmission modes.

**Table 12.19 Supported RxPDO transmission types**

Transmission type	Timing	Description
0 - 240	Synchronous	The RxPDO data is written to the target parameters when the next SYNC message is received.
241-251		Reserved.
252 - 253		Not used for RxPDOs.
254	Asynchronous	The RxPDO data is written to the target parameters when an OFF-to-ON (0-to-1) transition occurs in Pr <b>MM.36</b> . Pr <b>MM.36</b> must be reset to OFF for a minimum of 1ms to allow the RxPDO to be updated on the next OFF-ON transition. This allows the RxPDO update to be controlled by a digital input.
255	Asynchronous	The RxPDO data is written immediately to the target parameters.

Default values for the RxPDO COB-ID are shown in Table 12.20.

**Table 12.20 RxPDO transmission type default values**

RxPDO	Index	Default
1	0x1400	255
2	0x1402	255
3	0x1404	255
4	0x1405	255

### 12.6.4 RxPDO inhibit time

<b>Index</b>	0x1400-0x15FF	<b>Sub-index</b>	3
<b>Data type</b>	USIGN16	<b>Access</b>	RW

Inhibit time is not used for RxPDOs.

### 12.6.5 RxPDO event timer

<b>Index</b>	0x1400-0x15FF	<b>Sub-index</b>	5
<b>Data type</b>	USIGN16	<b>Access</b>	RW

Event timer is not used for RxPDOs.

## 12.7 RxPDO mapping parameters

The default configuration for SM-CANopen is RxPDOs 1, 3, 5 & 6 and TxPDOs 1,3, 5 & 6, this however may be changed using objects 0x2800 and 0x2801 (section 12.5.1 *RxPDO number configuration* on page 115). The destination parameters for data received from an RxPDO are specified in the RxPDO mapping parameters. Four

mapping parameters are provided for each RxPDO, allowing data to be mapped to all drive and SM-Applications (Unidrive SP only) parameters. RxPDO data can also be mapped to all CANopen object dictionary entries that allow PDO mapping.

The default mappings for RxPDOA(1) are derived from the mapping parameters (Pr **MM.20** to Pr **MM.23**) during initialisation, however, the mappings for all RxPDOs are dynamic, so changes made to the CANopen object dictionary mapping parameters (using SDO communications) will override settings made in the drive menu (**MM.xx**). Refer to section 7.7 *Changing PDO mapping parameters* on page 52 default mappings for RxPDOA(1) are shown in Table 12.21. RxPDO1 is enabled by default.

Index	Sub-index	Description	Data type	Access
0x1600	0	No of mapped application objects in RxPDO	UNSIGNED8	RW
0x1600	1	Channel 0 mapping	UNSIGNED32	RW*
0x1600	2	Channel 1 mapping	UNSIGNED32	RW*
0x1600	3	Channel 2 mapping	UNSIGNED32	RW*
0x1600	4	Channel 3 mapping	UNSIGNED32	RW*

**NOTE** \* - read/write only if the number of mapped application objects in RxPDO (Index 0x1600N sub 0) is set to 0. Refer to section 7.7 *Changing PDO mapping parameters* on page 52.

**NOTE** The actual index number is calculated by subtracting 1 from the PDO number and adding this number to the base address e.g. for 0x1600 PDO3 = 0x1602.

**Table 12.21 RxPDOA (by default RxPDO 1 ) default mapping**

Index	Sub-index	Description	Default	Mapping destination
0x1600	0	Number of mapped objects in RxPDO1	2	2 objects mapped by default
0x1600	1	Channel 0 mapping	0x20062A20	Pr <b>6.42</b> , derived from Pr <b>MM.20</b>
0x1600	2	Channel 1 mapping	0x20011520	Pr <b>1.21</b> , derived from Pr <b>MM.21</b>
0x1600	3	Channel 2 mapping	0x00000000	Not used with default mappings
0x1600	4	Channel 3 mapping	0x00000000	

**NOTE** The actual index number is calculated by subtracting 1 from the PDO number and adding this number to the base address e.g. for 0x1600 PDO3 = 0x1602.

**Table 12.22 RxPDOD (by default RxPDO 6) default mapping**

Index	Sub-index	Description	Default	
0x1605	0	Number of mapped objects in RxPDO6	2	2 objects mapped by default
0x1605	1	Channel 0 mapping	0x60400010	<i>controlword</i>
0x1605	2	Channel 1 mapping	0x60420010	<i>vl_target_velocity</i>
0x1605	3	Channel 2 mapping	0x00000000	Not used with default mappings
0x1605	4	Channel 3 mapping	0x00000000	

**NOTE** The actual index number is calculated by subtracting 1 from the PDO number and adding this number to the base address e.g. for 0x1600 PDO3 = 0x1602.

## 12.8 TxPDO communication parameters

<b>Index</b>	0x1800-0x19FF
<b>Object code</b>	Record
<b>Data type</b>	PDOCommPar

This section contains the communication parameters for the TxPDOs. SM-CANopen supports a total of 4 TxPDOs. Each PDO has a main index assigned to it, with individual parameters for the PDO accessed using sub-indices.

**Table 12.23 Supported TxPDOs (default settings)**

TxPDO	Index
A	0x1800-0x19FF
B	0x1800-0x19FF
C	0x1800-0x19FF
D	0x1800-0x19FF

All TxPDO configuration parameters are dynamic, i.e. any changes made to these parameters will take effect immediately.

**NOTE** The actual index number is calculated by subtracting 1 from the PDO number and adding this number to the base address e.g. for 0x1800 PDO3 = 0x1802.

### 12.8.1 Number of entries

Index	0x1800-0x19FF	Sub-index	0	Access	RO
<b>Default</b>	5	<b>Data type</b>	UNSIGNED8		

Defines the largest sub-index supported for the specified TxPDO.

**Table 12.24 TxPDO number of entries**

TxPDO	Index	Value
A	0x1800-0x19FF	5
B	0x1800-0x19FF	5
C	0x1800-0x19FF	5
D	0x1800-0x19FF	5

**NOTE** The actual index number is calculated by subtracting 1 from the PDO number and adding this number to the base address e.g. for 0x1600 PDO3 = 0x1602.

## 12.8.2 TxPDO COB-ID

<b>Index</b>	0x1800-0x19FF	<b>Sub-index</b>	1
<b>Data type</b>	UNSIGNED32	<b>Access</b>	RW

The COB-ID is the CAN identifier used by SM-CANopen to transmit TxPDO messages over the CANopen network. The COB-ID is usually calculated using the node address, as this will ensure that the TxPDO COB-ID is unique on the CANopen network.

<b>b31</b>	<b>b30</b>	<b>b29</b>	<b>b28 - b11</b>	<b>b10 - b0</b>
PDO Disable	RTR Disable	29-bit ID Enable	0000000000000000	11-bit ID

The upper 3 bits (b31-b29) are used to enable certain functions of the TxPDO.

**Table 12.25 PDO COB-ID configuration**

Function	Comment
PDO Disable	Set to 1 to disable the TxPDO. SM-CANopen will not transmit the TxPDO
RTR Disable	Set to 1 to disable RTR with the TxPDO.
29-bit ID Enable	SM-CANopen hardware does not support 29-bit CAN identifiers so this bit must always be 0.

DSP301 V4.1 specifies default COB-ID values for TxPDO1 to TxPDO4, while all higher TxPDOS must be disabled by default. Default values for the TxPDO COB-IDs are shown in Table 12.26.

**Table 12.26 TxPDO COB-ID default values**

TxPDO	Index	Default COB-ID
A	0x1800-0x19FF	0x0000180 + node address
B	0x1800-0x19FF	0x80000380 + node address
C	0x1800-0x19FF	0x80000000
D	0x1800-0x19FF	0x80000000

## 12.8.3 TxPDO transmission type

<b>Index</b>	0x1800-0x19FF	<b>Sub-index</b>	2
<b>Data type</b>	UNSIGNED8	<b>Access</b>	RW

The transmission type defines when the TxPDO data is read from the source parameters and when it is transmitted over the CANopen network. SM-CANopen supports all CANopen transmission modes.

**Table 12.27 Supported TxPDO transmission types**

Transmission type	Timing	Description
0	Acyclic, synchronous	The source data is read when the SYNC message is received. If the source data has changed, the TxPDO is transmitted.
1 - 240	Cyclic, synchronous	The source data is read and the TxPDO is transmitted every n SYNC messages, where n = transmission type.
252	Synchronous, RTR only	The source data is read when the SYNC message is received, but the TxPDO will only be transmitted when an RTR message is received. The RTR message must have the correct COB-ID for the required TxPDO.

**Table 12.27 Supported TxPDO transmission types**

Transmission type	Timing	Description
253	Asynchronous, RTR only	The source data is read and the TxPDO is transmitted when an RTR message is received. The RTR message must have the correct COB-ID for the required TxPDO.
254	Asynchronous, event trigger	The source data is read and the TxPDO is transmitted in response to 2 events: 1. An OFF-to-ON (0-to-1) transition in Pr <b>MM.36</b> . Pr <b>MM.36</b> must be reset to OFF for a minimum of 1ms to allow the TxPDO to be transmitted on the next OFF-ON transition. This allows the TxPDO to be controlled by a digital input. 2. Event timer. Refer to section 12.8.5 <i>TxPDO event timer</i> on page 123 for more details.
255	Asynchronous, timer trigger	The source data is read and the TxPDO is transmitted in response to the event timer. Refer to section 12.8.5 <i>TxPDO event timer</i> on page 123 for more details.

**NOTE** Please refer to Pr **MM.06** on section 5.11 *SM-CANopen operating status* on page 42 for important information on transmission types.

If a TxPDO has transmission type 0 to 240, 254 or 255, the CANopen master controller can use an RTR message (with the COB-ID of the required PDO) to get the SM-CANopen to re-transmit the required TxPDO. SM-CANopen does NOT update the data values for the requested TxPDO; data update will only occur when specified for the TxPDO transmission type.

If a TxPDO is configured with transmission type 252 or 253, it can only be transmitted in response to an RTR message from the CANopen master controller.

Default values for the TxPDO transmission types are shown in Table 12.27.

**Table 12.28 TxPDO transmission type default values**

TxPDO	Index	Default	Comment
A (default = 1)	0x1800-0x19FF	255	Specified in Pr <b>MM.41</b> /SDO configuration
B (default = 3)	0x1800-0x19FF	255	SDO configuration
C (default = 5)	0x1800-0x19FF	255	SDO configuration
D (default = 6)	0x1800-0x19FF	255	SDO configuration

**NOTE** The actual index number is calculated by subtracting 1 from the PDO number and adding this number to the base address e.g. for 0x1800 PDO3 = 0x1802.

**12.8.4 TxPDO inhibit time**

Index	0x1800-0x19FF	Sub-index	3	Access	RW
Default	0	Data type	USIGN16		

The inhibit time functionality is not implemented in SM-CANopen.

**12.8.5 TxPDO event timer**

Index	0x1800-0x19FF	Sub-index	5	Access	RW
Default	0	Data type	USIGN16		

The TxPDO event timer specifies the time period (in ms) between transmission of TxPDOs with transmission type 254 or 255 (see section 12.28 *TxPDO transmission type default values* on page 123). Set the TxPDO event timer to 0 to disable the event timer.

**NOTE** The actual index number is calculated by subtracting 1 from the PDO number and adding this number to the base address e.g. for 0x1800 PDO3 = 0x1802.

## 12.9 TxPDO mapping parameters

The source parameters for data transmitted on a TxPDO are specified in the TxPDO mapping parameters. 4 mapping parameters are provided for each TxPDO, allowing data to be mapped to all drive and SM-Applications parameters. TxPDO data can also be mapped to all CANopen object dictionary entries that allow PDO mapping.

The default mappings for TxPDOA are derived from the mapping parameters (Pr MM.10 to Pr MM.13) during initialisation and configured via the menu, therefore changes made via these parameters will require a reset in order to take effect. However, the mappings for all 4 TxPDOs can be changed via the appropriate CANopen object dictionary mapping objects (using SDO communications), changes made via this method will take effect immediately.

The SM-CANopen will NOT update the drive mapping parameters if the CANopen object dictionary mapping parameters are changed after the SM-CANopen has initialised. This means that the SM-CANopen will revert to the drive parameter-defined mappings during the next initialisation.

**Table 12.29 TxPDO mapping parameters**

Index	Sub-index	Description	Data type	Access
0x1A00-0x1BFF	0	Number of mapped objects in TxPDO	UNSIGNED8	RW
0x1A00-0x1BFF	1	Channel 0 mapping	UNSIGNED32	RW*
0x1A00-0x1BFF	2	Channel 1 mapping	UNSIGNED32	RW*
0x1A00-0x1BFF	3	Channel 2 mapping	UNSIGNED32	RW*
0x1A00-0x1BFF	4	Channel 3 mapping	UNSIGNED32	RW*

**NOTE** \* - read/write only if the number of mapped application objects in TxPDO (index 0x1A00 sub-index 0) is set to 0. Refer to section 7.7 *Changing PDO mapping parameters* on page 52.

**NOTE** The actual index number is calculated by subtracting 1 from the PDO number and adding this number to the base address e.g. for 0x1600 PDO3 = 0x1602.

The default mappings for RxPDO1 are shown in Table 12.30. RxPDO1 is enabled by default. The default configuration for SM-CANopen is RxPDOs 1, 3, 5 & 6 and TxPDOs 1,3, 5 & 6, this however may be changed using objects 0x2800 and 0x2801 (section 12.5.1 *RxPDO number configuration* on page 115). The destination parameters for data received from an RxPDO are specified in the RxPDO mapping parameters. Four mapping parameters are provided for each RxPDO, allowing data to be mapped to all drive and SM-Applications (Unidrive SP only) parameters. RxPDO data can also be mapped to all CANopen object dictionary entries that allow PDO mapping.

**Table 12.30 TxPDOA (by default TxPDO 1)**

Index	Sub-index	Description	Default	Mapping destination
0x1A00	0	Number of entries	2	
0x1A00	1	Channel 0 mapping	0x200A2820	Pr 10.40
0x1A00	2	Channel 1 mapping	0x20020120	Pr 2.01
0x1A00	3	Channel 2 mapping	0x00000000	Not used with default mappings
0x1A00	4	Channel 3 mapping	0x00000000	

Profile position mode is not supported in the SM-CANopen, but TxPDO3 is provided for use with a DPL profile implementation. By default, all TxPDO3 mappings are set to 0.

**NOTE** The actual index number is calculated by subtracting 1 from the PDO number and adding this number to the base address e.g. for 0x1600 PDO3 = 0x1602.

**Table 12.31 TxPDOB (by default TxPDO 3)**

Index	Sub-index	Description	Default	Mapping destination
0x1A02	0	Number of entries	2	
0x1A02	1	Channel 0 mapping	0x00000000	Not used with default mappings
0x1A02	2	Channel 1 mapping	0x00000000	
0x1A02	3	Channel 2 mapping	0x00000000	
0x1A02	4	Channel 3 mapping	0x00000000	

**NOTE** The actual index number is calculated by subtracting 1 from the PDO number and adding this number to the base address e.g. for 0x1600 PDO3 = 0x1602.

By default, TxPDO5 is disabled, so the mapping objects are all set to 0. When DSP402 profiles are enabled, the specified mappings for profile torque mode are shown in Table 12.32.

**Table 12.32 TxPDO C (by default TxPDO 5) default mapping**

Index	Sub-index	Description	Default	Mapping destination
0x1A04	0	Number of entries	2	
0x1A04	1	Channel 0 mapping	0x60410010	<i>status word</i>
0x1A04	2	Channel 1 mapping	0x60770010	<i>torque_actual_value</i>
0x1A04	3	Channel 2 mapping	0x00000000	Not used with default mappings
0x1A04	4	Channel 3 mapping	0x00000000	

**NOTE** The actual index number is calculated by subtracting 1 from the PDO number and adding this number to the base address e.g. for 0x1600 PDO3 = 0x1602.

By default, TxPDO6 is disabled, so the mapping objects are all set to 0. When DSP402 profiles are enabled, the specified mappings for velocity mode are shown in Table 12.33.

**Table 12.33 TxPDOD (by default TxPDO 6) default mapping**

Index	Sub-index	Description	Default	Mapping destination
0x1A05	0	Number of entries	2	
0x1A05	1	Channel 0 mapping	0x60410010	<i>statusword</i>
0x1A05	2	Channel 1 mapping	0x60440010	<i>vl_control_effort</i>
0x1A05	3	Channel 2 mapping	0x00000000	Not used with default mappings
0x1A05	4	Channel 3 mapping	0x00000000	

**NOTE** The actual index number is calculated by subtracting 1 from the PDO number and adding this number to the base address e.g. for 0x1600 PDO3 = 0x1602.

## 12.10 Network management objects (NMT)

SM-CANopen uses the standard CANopen network management state machine to determine the behaviour of the communication objects. Figure 12-1 shows the NMT state machine, and the different state transitions that are possible.

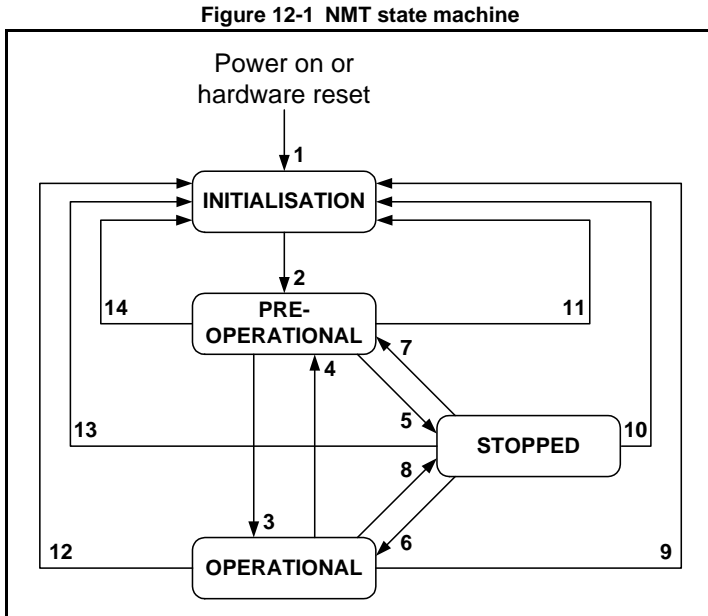

**Table 12.34 NMT state machine transitions**

Transition	Transition initiated by
1	At power on or hardware reset, enter INITIALISATION automatically
2	INITIALISATION complete, enter PRE-OPERATIONAL automatically
3, 6	START_REMOTE_NODE
4, 7	ENTER_PRE_OPERATIONAL
5, 8	STOP_REMOTE_NODE
9, 10, 11	RESET_NODE
12, 13, 14	RESET_COMMUNICATION

### 12.10.1 NMT states

CANopen has various different communication objects, but some objects are only active in certain NMT states. Table 12.35 lists the communication objects supported by SM-CANopen, and the NMT states in which each object is active.

**Table 12.35 NMT states and active messages**

Object	INITIALISATION	PRE-OPERATIONAL	OPERATIONAL	STOPPED
PDO	-	-	Active	-
SDO	-	Active	Active	-
SYNC	-	Active	Active	-

**Table 12.35 NMT states and active messages**

Object	INITIALISATION	PRE-OPERATIONAL	OPERATIONAL	STOPPED
Emergency	-	Active	Active	-
Boot-up	Active	-	-	-
NMT		Active	Active	Active

### 12.10.2 Initialisation

SM-CANopen may be switched into **Initialisation** from any other state using the RESET\_NODE or RESET\_COMMUNICATION commands.

### 12.10.3 Pre-operational

The synchronisation object, emergency object, NMT objects and SDO communications are all active in the PRE-OPERATIONAL state, allowing device configuration to take place. PDOs do not exist in the PRE-OPERATIONAL state and are inactive. This allows PDO configuration and mapping objects to be configured without interfering with active communications.

SM-CANopen may be switched into PRE-OPERATIONAL from OPERATIONAL (transition 4) or STOPPED (transition 7) using the ENTER\_PRE-OPERATIONAL command.

### 12.10.4 Operational

All communication objects are active in the OPERATIONAL state. All configured PDOs are created when SM-CANopen enters the OPERATIONAL state, using the parameter values in the object dictionary. SDO communications remain active in the OPERATIONAL state.

SM-CANopen may be switched into OPERATIONAL from PRE-OPERATIONAL (transition 3) or STOPPED (transition 6) using the START\_REMOTE-NODE command.

### 12.10.5 Stopped

All communications (except NMT and heartbeat) are stopped when the SM-CANopen is switched into the STOPPED state. SM-CANopen will only respond to NMT messages while in the STOPPED state, so it must be switched into the PRE-OPERATIONAL or OPERATIONAL state to re-start communications. The heartbeat error control protocol remains active during the STOPPED state.

SM-CANopen may be switched into STOPPED from PRE-OPERATIONAL (transition 5) or OPERATIONAL (transition 8) using the STOP\_REMOTE\_NODE command.

## 12.11 NMT commands

Network Management (NMT) commands are low-level CANopen commands that are used to switch SM-CANopen between the different NMT states. NMT messages always have a CAN identifier of 0x000 and contain 2 data bytes.

**Table 12.36 NMT message structure**

CAN identifier	Command (See Table 12.37)	Node ID
0x000	See Table 12.37	Target node

**Table 12.37 NMT commands**

Command	Code
START_REMOTE_NODE	1
STOP_REMOTE_NODE	2
ENTER_PRE_OPERATIONAL	128
RESET_NODE	129
RESET_COMMUNICATION	130

## 12.12 Layer setting services (LSS)

SM-CANopen supports the complete CANopen Layer Setting Service protocol, as defined in DSP205 V1.1. LSS provides the ability for a CANopen device with LSS Master capabilities to enquire and change the settings of certain parameters of the local layers on a LSS Slave CANopen device via the CAN network.

The following parameters can be enquired and/or changed by the use of LSS:

- Node-ID of the CANopen slave
- Bit timing parameters of the physical layer (baud rate)
- LSS address (Identity Object, Index 0x1018). The LSS address consists of Vendor ID, Product Code, Revision Number and Serial Number, and is unique to every SM-CANopen.

### 12.12.1 Enabling LSS

LSS functionality is enabled automatically if SM-CANopen initialises without an active node address, or when an NMT Stop command is issued. In default configuration, SM-CANopen will have LSS enabled. There is no NMT functionality when LSS is active.

When LSS is active, all CANopen devices will receive LSS commands on COB-ID 2021 (0x07E5) and respond on COB-ID 2020 (0x07E4). All LSS messages are 8 bytes long.

### 12.12.2 Configuring SM-CANopen via LSS

When SM-CANopen enters LSS mode, it is in an “operational” state, and no configuration can take place. SM-CANopen must be switched into “configuration” by:

1. addressing an SM-CANopen using its complete (and unique) LSS address.
2. switching all LSS devices into the “configuration” state.

Switching “all” devices into the “configuration” state should only be used when there is a single node on the network in LSS mode, or a bit timing change is required. This can be used for adding a single node at a time to the network without knowing its LSS address, configuring and activating it before adding another new device.

### 12.12.3 Switch mode global

The switch mode global command is used to change the LSS state of all nodes currently in LSS.

**Table 12.38 Global Modes**

COB-ID	Byte		
	0	1	2 - 7
0x7E5	0x04	Mode	Reserved (set to 0)

Mode 0 - switches all devices into “operational” mode.

Mode 1 - switches all devices into “configuration” mode.

If a device has a node address, the switch mode global command to “operational” will cause the device to re-initialise and activate with the new settings.

### 12.12.4 Switch mode selective

The switch mode selective commands are used to change a single device into the “configuration” state. A series of 4 commands are issued containing the 4 values of the LSS address. If all 4 values match the local values, and are received in the correct sequence, SM-CANopen will enter the “configuration” state and respond with a message to indicate that is now in this state.

All parts of the LSS address are obtained from the identity object (0x1018).

### 12.12.5 Select vendor ID

Command to specify the Vendor ID of the target SM-CANopen.

**Table 12.39 Vendor ID**

COB-ID	Byte		
	0	1 - 4	5 - 7
0x7E5	0x40	Vendor ID	Reserved (set to 0)

### 12.12.6 Select product code

Command to specify the Product Code of the target SM-CANopen.

**Table 12.40 Product Code**

COB-ID	Byte		
	0	1 - 4	5 - 7
0x7E5	0x41	Product Code	Reserved (set to 0)

### 12.12.7 Select revision number

Command to specify the Revision Number of the target SM-CANopen.

**Table 12.41 Revision Number**

COB-ID	Byte		
	0	1 - 4	5 - 7
0x7E5	0x42	Revision Number	Reserved (set to 0)

### 12.12.8 Select serial number

Command to specify the Serial Number of the target SM-CANopen.

**Table 12.42 Serial Number specification**

COB-ID	Byte		
	0	1 - 4	5 - 7
0x7E5	0x43	Serial Number	Reserved (set to 0)

### 12.12.9 Response

When a device has been identified, it will respond to acknowledge the mode change.

**Table 12.43**

COB-ID	Byte	
	0	1 - 7
0x7E4	0x44	Reserved (set to 0)

## 12.12.10 Configure node-ID

Configure Node-ID is used to assign a new node address to the device currently in “configuration” state. For SM-CANopen, the new node address will be written to Pr **MM.03**. Once a device has a configured node ID, it will reset and start up using the new address when it is next switched in “operational” state.

**Table 12.44 Node configuration**

COB-ID	Byte		
	0	1	2 - 7
0x7E5	0x11	Node ID	Reserved (set to 0)

The device will respond to acknowledge the new node-ID.

**Table 12.45 Node-ID acknowledgement**

COB-ID	Byte			
	0	1 (see table 12.50)	2	3 - 7
0x7E4	0x11	Error code	Spec error	Reserved (set to 0)

**Table 12.46 Error Types**

Error Type	Byte	Description
Error code	0	Node-ID accepted
Error code	1	Node-ID out of range
Spec error	0	Always 0

## 12.12.11 Changing data rate

LSS allows the network data rate to be changed safely without any bus-off errors occurring. Every device node on the network must be in the “configuration” state. LSS protocol specifies a delay period before and after the data rate change during which devices are not allowed to place any message on the CAN network. This ensures that every node is able to change data rate safely without causing bus-off errors.

## 12.12.12 Configure bit timing

This is used to set a new value for the data rate. When a new data rate is specified' SM-CANopen will update Pr **MM.04**, but the new setting will not take effect until the communications are re-initialised, or Activate Bit Timings command is issued.

**Table 12.47 Configure bit timing**

COB-ID	Byte			
	0	1	2	3 - 7
0x7E5	0x13	Table sel	Table ind	Reserved (set to 0)

Table sel 0 = standard CiA bit timings.

Table ind 0 to 8 = standard data rate settings. Refer to section 10.4 *SM-CANopen data rate* on page 72.

The devices will respond to acknowledge receipt of the new bit timings.

**Table 12.48 Bit acknowledgement**

COB-ID	Byte			
	0	1	2	3 - 7
0x7E4	0x13	Err code	Spec error	Reserved (set to 0)

Err code 0 = bit timing accepted.

Err code 1 = bit timing not supported.

Spec error = always 0.

### 12.12.13 Activate bit timing

This command tells all devices to change to the new data rate. If any of the devices have different data rate settings, or are not in “Configuration”, a conflict will occur and a bus-off error may occur. The switch delay time is specified in milliseconds, and specifies the idle time before and after the data rate change during which no devices are allowed to communicate on the network.

**Table 12.49 Bit activation**

COB-ID	Byte		
	0	1 - 2	3 - 7
0x7E5	0x15	Switch delay	Reserved (set to 0)

### 12.12.14 Store configuration

The store configuration command will force all drive parameters to be saved, provided the drive is not in a tripped state.

**Table 12.50 Store configuration**

COB-ID	Byte	
	0	1 - 7
0x7E5	0x17	Reserved (set to 0)

SM-CANopen will respond to acknowledge the save request.

**Table 12.51 Configuration acknowledgement**

COB-ID	Byte			
	0	1	2	3 - 7
0x7E4	0x17	Err code	Spec error	Reserved (set to 0)

Err code 0 = parameters saved.

Err code 1 = drive tripped, parameters were not saved.

Spec error = always 0.

### 12.12.15 Inquire Service

The Inquire Service command can be used to receive information about a device that is in the “configuration” state. Only one device may be in this state when this command is used.

If new devices are added to the CANopen network one at a time, their default mode will be LSS. By using the Switch Mode Global and Inquire Service commands, the master can retrieve the information that is needed for addressing each device before configuring it and switching it out of LSS.

## 12.12.16 Inquire vendor ID

Request message

**Table 12.52 Request message**

COB-ID	Byte	
	0	1 - 7
0x7E5	0x5A	Reserved (set to 0)

Response message

**Table 12.53 Response message**

COB-ID	Byte		
	0	1 - 4	5 - 7
0x7E4	0x5A	Vendor ID	Reserved (set to 0)

## 12.12.17 Inquire product code

Request message

**Table 12.54 Request message**

COB-ID	Byte	
	0	1 - 7
0x7E5	0x5B	Reserved (set to 0)

Response message

**Table 12.55 Response message**

COB-ID	Byte		
	0	1 - 4	5 - 7
0x7E4	0x5B	Product Code	Reserved (set to 0)

## 12.12.18 Inquire revision number

Request message

**Table 12.56 Request message**

COB-ID	Byte	
	0	1 - 7
0x7E5	0x5C	Reserved (set to 0)

Response message

**Table 12.57 Response message**

COB-ID	Byte		
	0	1 - 4	5 - 7
0x7E4	0x40	Revision Number	Reserved (set to 0)

## 12.12.19 Inquire serial number

Request message

**Table 12.58 Request message**

COB-ID	Byte	
	0	1 - 7
0x7E5	0x5D	Reserved (set to 0)

Response message

**Table 12.59 Response message**

COB-ID	Byte		
	0	1 - 4	5 - 7
0x7E4	0x40	Serial Number	Reserved (set to 0)

### 12.12.20 Inquire node-ID

Request message

**Table 12.60 Request message**

COB-ID	Byte	
	0	1 - 7
0x7E5	0x5A	Reserved (set to 0)

Response message

**Table 12.61 Response message**

COB-ID	Byte		
	0	1	2 - 7
0x7E4	0x40	Node ID	Reserved (set to 0)

## 12.13 Emergency object

### 12.13.1 What is the emergency object?

Emergency objects are transmitted by the SM-CANopen when it detects that the drive has tripped. They are high priority messages that inform the CANopen master controller that some sort of error has occurred. It is up to the CANopen master controller to take appropriate action.

Emergency objects are suitable for interrupt-type error alerts. An emergency object is transmitted only once per error event and provided that no new errors occur, no further emergency objects will be transmitted.

### 12.13.2 Emergency object format

The emergency object consists of a total of 8 data bytes. The first 3 bytes are defined by the CANopen specification, and the remaining 5 bytes are manufacturer-specific. SM-CANopen will return the Unidrive SP trip code and the SM-CANopen error code, allowing the CANopen master controller to determine exactly what fault has occurred.

Bytes 5 to 7 are always transmitted, but will always be set to 0.

**Table 12.62 Emergency object format**

COB-ID	Byte				
	0	1	2	3	4
COB-ID EMCY (Index 0x1014)	Emergency error code (See Table 12.63)		Error register (Index 0x1001)	Drive trip code	SM-CANopen error code (Pr <b>MM.50</b> )

The CANopen specification defines a list of standard error codes. Supported CANopen emergency error codes (and the drive trips that will produce the emergency error code) are listed in Table 12.63. All other drive trips will produce the generic error code, 0x1000.

**Table 12.63 Emergency error codes**

Emergency error code	Drive trip codes	Description
0x0000	----	Error reset or no error.
0x1000	All other trip codes	Generic error.
0x2300	20, 43, 111-118, 141-148	Current. This error will occur if any type of over-current error is detected in the output stage(s) of the drive.
0x3000	8	Voltage. This error will occur if the drive external +10V reference voltage is short-circuit.
0x3100	32	Voltage, main supply. This error will occur if a problem is detected with the main supply voltage to the drive.
0x3200	1, 2, 5, 9, 131-138	Voltage, internal. This error will occur if any problem is detected with the internal voltages in the drive.
0x4200	21-23, 27, 121-128	Temperature. This error will occur if any over-temperature problem is detected on the drive.
0x5000	220-229	Hardware fault. This error will occur if the drive fails due to internal problems, indicated by an "HF" trip.

For full details about each trip, refer to the drive documentation.

## 12.14 Emergency object state

The SM-CANopen may be in one of two emergency states, as shown in Figure 12-2 on page 135.

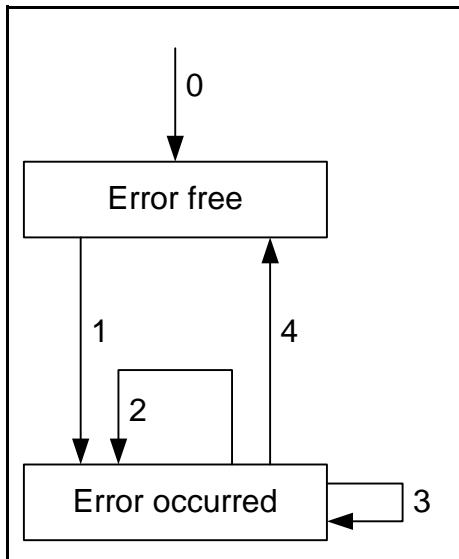

**Figure 12-2 Emergency object states**

**Table 12.64 Emergency object state transitions**

Transition	Reference	Description
0	Initialisation	After initialisation, SM-CANopen enters the error free state if no error is detected. The emergency object is not transmitted.
1	Error occurred	SM-CANopen detects an error, transmits the emergency object once, and enters the error state.
2	Reset, new error occurred	One error (but not all errors) have been cleared. SM-CANopen will transmit another emergency object with information about the remaining error.
3	New error occurred	SM-CANopen has detected a new error condition, while in the error state. SM-CANopen remains in error state and transmits another emergency object with the appropriate error codes.
4	Reset, error cleared	All errors have been cleared. SM-CANopen will return to the error free state, and transmit an emergency object with the emergency error code set to 0x0000.

**12.14.1 Error register**

The error register is used by the SM-CANopen to indicate that an error has occurred, and can be mapped to TxPDOs if required. If a bit is set to 1, the specified error has occurred.

**Table 12.65 Error register**

Bit	Error	Description
0	Generic error	Set if any other bits in the register are set.
1	Current	Set if current errors occur (10.09/10.17 - SP)
2	Voltage	When drive detects a UU error.
3	Temperature	Set if temperature errors occur (10.18 - SP)
4	Communication error	Always set to 0
5	Device profile specific	
6	Reserved	
7	Manufacturer specific	Set if Pr 10.19 is set.

**12.14.2 Generating emergency objects from DPL**

Emergency objects are now supported from DPL. This allows an error code to be written to a DPL variable to produce an emergency object message on the network. To use this feature an object association needs to be made to object 0x1001 sub-index 0. This should be a 32 bit read-only object. To send a new emergency message the error code must be specified in the lower 16 bits (bytes 0 and 1) of this object. Byte 2 will be a logical "OR" with the error register byte created in the modules emergency message handler, and byte 3 can be used to set the 3rd of the manufacturer specific bytes of the emergency object. The modules emergency handler checks this association and manages it accordingly, therefore if an error is produced by the host drive, then by the module itself, both errors must be cleared in order to transmit the all-clear empty emergency object.

**NOTE** Please refer to Chapter 11.12.1 *DPL function call* on page 86 for more information.

## 12.15 Unidrive SP and Commander SK: device profiles

Basic implementations of two DSP402 device profiles (profile torque and velocity) have been included in the SM-CANopen, and supported objects are detailed in this section. Additional features may be implemented in an SM-Applications DPL program on (Unidrive SP only).

### 12.15.1 Enable DSP402 device profiles

**Table 12.66 Enable DSP402**

Name	DSP402 device profile enable	
	Pr <b>MM.37</b>	Default
Range		OFF (0) or ON (1)
Access		RW

Set DSP402 device profile enable (Pr **MM.37**) to ON to enable the device profiles and select the required profile using **modes\_of\_operation** (see section 12.15.13 *Modes of operation* on page 146).

Cyclic data compression (Pr **MM.34**) MUST be enabled and the data format (Pr **MM.05**) must be set to 0 to use the DSP402 device profiles (see section 11.8 *Cyclic data compression* on page 84 and section 5-10 *SDO Configuration* on page 39).

Refer to section 11.13 *Unidrive SP: SM-Applications object priority* on page 88 to ensure that the correct object implementations will be accessed. If a device profile is written entirely in the SM-Applications DPL program, it is recommended that the internal SM-CANopen profiles should be disabled.

### 12.15.2 Conversion factors

The velocity mode profile specifies velocity parameters in rpm or percent, time parameters in seconds, and ramps in rpm/second. The drive uses different units for the different types of parameter, so conversion factors must be used.

#### Hz/rpm functions

The Hz/rpm functions are used when the drive is in open loop mode, as all speed reference parameters within the drive have units of Hz. The number of motor pole pairs is read from the drive whenever these equations are used.

$$Hz = rpm * PolePairs / 60$$

$$rpm = Hz * 60 / PolePairs$$

#### Ramp conversion functions

The ramp conversion functions are used to convert between rpm/s (specified using DeltaSpeed and DeltaTime) and the ramp specification used by the drive.

In open loop and SE mode, drive ramp units are specified in s/100Hz.

$$Secs/100Hz = DeltaTime * (100 * 6 / PolePairs) * 100 / DeltaSpeed$$

In closed loop and servo modes, drive ramp units are specified in s/1000rpm.

$$Secs/1000rpm = DeltaTime * 1000 * 1000 / DeltaSpeed$$

### 12.15.3 Parameter data object mapping

The **controlword** and **statusword** used by the device profile modes are not the standard drive control and status words. They are defined in CiA DSP-402 V1.1, "Device Profile for Drive and Motion Control".

### 12.15.4 Profile torque mode

When the profile torque mode is selected, RxPDO5 and TxPDO5 consist of two 16-bit words. The specified mappings for profile torque mode are shown in Table 12.67.

**Table 12.67 PDO5 mapping**

Data word	Mapped object	Mapping status
RxPDO5 Word 0	0x6040	<i>controlword</i>
RxPDO5 Word 1	0x6071	<i>target_torque</i>
TxPDO5 Word 0	0x6041	<i>statusword</i>
TxPDO5 Word 1	0x6077	<i>torque_actual_value</i>

### 12.15.5 Velocity mode

When the velocity mode profile is selected, RxPDO6 and TxPDO6 consists of two 16-bit words. The specified mappings for velocity mode are shown in Table 12.68.

**Table 12.68 PDO6 mapping**

Data word	Mapped object	Mapping status
RxPDO6 Word 0	0x6040	<i>controlword</i>
RxPDO6 Word 1	0x6042	<i>vl_target_velocity</i>
TxPDO6 Word 0	0x6041	<i>statusword</i>
TxPDO6 Word 1	0x6044	<i>vl_control_effort</i>

### 12.15.6 Common entries

The common objects may be used by all supported profiles.

**Table 12.69 Supported common objects**

Index	Object	Name	Type	Access	PDO mapping
0x603F	VAR	<i>error_code</i>	UNSIGNED16	RO	Yes
0x6502	VAR	<i>supported_drive_modes</i>	UNSIGNED32	RO	Yes

### 12.15.7 Error code

**Table 12.70 error\_code**

<b>Index</b>	0x603F	<b>Object code</b>	VAR	<b>Access</b>	RO
<b>Sub-index</b>	0	<b>Data type</b>	UNSIGNED16	<b>PDO mapping</b>	Yes
<b>Default</b>	N/A	<b>Units</b>	None		

The *error\_code* captures the code of the last error that occurred in the drive. It corresponds to the value of the low 16 bits of object 0x1003, *pre\_defined\_error\_field*.

## 12.15.8 Supported drive modes

**Table 12.71 supported\_drive\_modes**

<b>Index</b>	0x6502	<b>Object code</b>	VAR	<b>Access</b>	RO
<b>Sub-index</b>	0	<b>Data type</b>	UNSIGNED32	<b>PDO mapping</b>	Yes
<b>Default</b>	0xA	<b>Units</b>	None		

The SM-CANopen supports profile torque mode and velocity mode.

**Table 12.72 supported\_drive\_modes bit descriptions**

Bit number	Description
0	Profile position mode
1	Velocity mode
2	Profile velocity mode (not supported)
3	Profile torque mode
4	Reserved
5	Homing mode (not supported)
6	Interpolated position mode (not supported)
7 to 15	Reserved
16 to 31	Manufacturer specific

### Device control

Device control objects are used to control the operation of the drive.

**Table 12.73 Device control supported objects**

Index	Object	Name	Type	Access	PDO mapping
0x6040	VAR	<i>controlword</i>	UNSIGNED16	RW	Yes
0x6041	VAR	<i>statusword</i>	UNSIGNED16	RW	Yes
0x605A	VAR	<i>quick_stop_option_code</i>	INTEGER16	RW	No
0x605B	VAR	<i>shut_down_option_code</i>	INTEGER16	RW	No
0x605C	VAR	<i>disable_operation_option_code</i>	INTEGER16	RW	No
0x6060	VAR	<i>modes_of_operation</i>	INTEGER8	WO	Yes
0x6061	VAR	<i>modes_of_operation_display</i>	INTEGER8	RO	Yes

### Controlword

<b>Index</b>	0x6040	<b>Object code</b>	VAR	<b>Access</b>	RW
<b>Sub-index</b>	0	<b>Data type</b>	UNSIGNED16	<b>PDO mapping</b>	Yes
<b>Default</b>	N/A	<b>Units</b>	None		

**controlword** provides the commands for logical control (enable, run, reset, etc.) of the drive, according to the pre-defined **controlword** state machine. In each state, the SM-CANopen will convert **controlword** and set the drive control word (Pr 6.42) as required to attain the required operating state.

The drive control word must be enabled by setting Pr 6.43 to ON (or 1) to allow **controlword** to control Pr 6.42.

**Table 12.74 Controlword bit descriptions**

Bit	Name	Description
0	SWITCH ON	Used (with <b>controlword</b> b7) to control the operating state of the device profile.
1	DISABLE VOLTAGE	
2	QUICK STOP	
3	ENABLE OPERATION	
4	Operation mode specific	Not used by SM-CANopen
5		
6		
7	FAULT RESET	Used (with <b>controlword</b> b0-b3) to control the operating state of the device profile.
8-10	Reserved	Reserved
11	AUTO	Set to 1 to enable <b>controlword</b> control of the drive. AUTO directly controls the AUTO bit (b7) of Pr 6.42. Refer to <i>Unidrive SP Advanced User Guide</i> for more details about Pr 6.42.
12-15	Manufacturer specific	Not used by SM-CANopen

7 device commands are used to switch between different control states, and these are listed in Table 12.75.

**Table 12.75 Example control words**

Command	FAULT RESET	ENABLE OPERATION	QUICK STOP	DISABLE VOLTAGE	SWITCH ON	Transitions affected
Shutdown	0	X	1	1	0	2, 6, 8
Switch on	0	X	1	1	1	3
Disable voltage	0	X	X	0	X	7, 9, 10, 12
Quick stop	0	X	0	1	X	7, 10, 11
Disable operation	0	0	1	1	1	5
Enable operation	0	1	1	1	1	4, 16
Fault reset	0-1	X	X	X	X	15

States may be changed using the **controlword** and/or internal events. The current state can be read using the statusword.

Figure 12-3 controlword state diagram

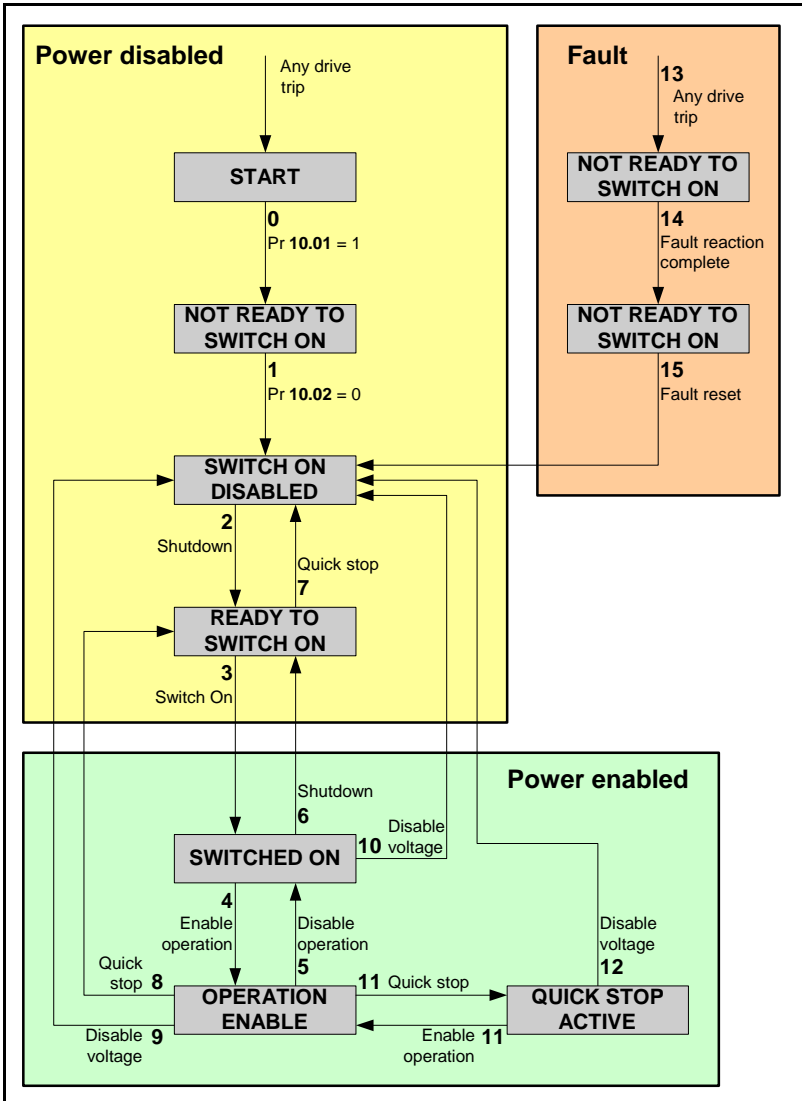

Safety Information
Introduction
Mechanical Installation
Electrical Installation
Getting Started
EPS Files
Cyclic Data
Non-Cyclic Data
Control and Status Words
Diagnostics
Advanced Features
<b>CANopen Reference</b>
Quick Reference
Glossary Of Terms
Index

State transitions are caused by internal events in the drive or by commands received from the host via the **controlword** (refer to Figure 12-3 *controlword state diagram* on page 141).

**Table 12.76 State transitions for profile control**

State transition	Event	Action
0	Pr 10.01 = 1	Drive must not be tripped when <b>controlword</b> initialises.
1	Pr 10.02 = 0	Drive must be disabled when <b>controlword</b> initialises.
2	<b>controlword</b> = "Shutdown"	Specified ramp mode selected in drive.
3	<b>controlword</b> = "Switch on"	Select decel ramp 1, Pr 2.20 = 1 Set decel ramp rate, Pr 2.21 as required Set Pr 6.42 bit 0 to 1.
4	<b>controlword</b> = "Enable operation"	Select decel ramp 1, Pr 2.20 = 1 Set decel ramp rate, Pr 2.21 as required Set Pr 6.42 bit 1 to 1.
5	<b>controlword</b> = "Disable operation"	Specified ramps selected in drive Reset Pr 6.42 bit 1 to 0.
6	<b>controlword</b> = "Shutdown"	Specified ramps selected in drive Reset Pr 6.42 bit 1 to 0.
7	<b>controlword</b> = "Quick stop"	Move to Switch On Disabled.
8	<b>controlword</b> = "Shutdown"	Specified ramps selected in drive Reset Pr 6.42 bit 0 and bit 1 to 0.
9	<b>controlword</b> = "Disable voltage"	Reset Pr 6.42 bit 0 and bit 1 to 0.
10	<b>controlword</b> = "Disable voltage" or "Quick stop"	Specified ramps selected in drive Reset Pr 6.42 bit 0 to 0.
11	<b>controlword</b> = "Quick stop"	Specified ramps selected in drive Reset Pr 6.42 bit 1 to 0.
12	Quick stop complete or controlword = "Disable voltage"	Reset Pr 6.42 bit 0 to 0.
13	Pr 10.01 = 1	drive trip.
14	Fault reaction complete	Reset Pr 6.42 bit 0 and bit 1 to 0.
15	<b>controlword</b> = "Fault reset"	Specified ramps selected in drive.
16	<b>controlword</b> = "Enable operation"	Specified ramps selected in drive Reset Pr 6.42 bit 1 to 1.

If a command is received which causes a change of state, this command must be processed completely and the new state attained before the next command can be processed.

**NOTE** State transition 16 is only available if the **quick\_stop\_option\_code** is set to 5, 6, 7 or 8. Specified ramps are defined by **shutdown\_option\_code**, **quick\_stop\_option\_code** and **disable\_operation\_option\_code**.

## 12.15.9 Statusword

<b>Index</b>	0x6041	<b>Object code</b>	VAR	<b>Access</b>	RO
<b>Sub-index</b>	0	<b>Data type</b>	UNSIGNED16	<b>PDO mapping</b>	Yes
<b>Default</b>	N/A	<b>Units</b>	None		

The **statusword** indicates the current status of the drive. The **statusword** bits are defined in the Table 12.77.

**Table 12.77 statusword bit descriptions**

Bit	Name	Source
0	READY TO SWITCH ON	Controlled by the device control state machine (see Figure 12.78 on page 143).
1	SWITCHED ON	
2	OPERATION ENABLED	
3	FAULT	
4	VOLTAGE DISABLED	VOLTAGE_DISABLED will be set to 1 when SM-CANopen is responding to the “Disable voltage” command in the <b>controlword</b> .
5	QUICK STOP	Controlled by the device control state machine (see Figure 12.78 on page 143).
6	SWITCH ON DISABLED	
7	Reserved	
8	Reserved	
9	REMOTE	Indicates that the drive is being controlled by <b>controlword</b> . Set to 1 if both control word enable (Pr 6.43) and AUTO bit (Pr 6.42 bit 7) are set to 1.
10	TARGET	Indicates the “At Speed” indication (Pr 10.06) from the drive. When quick stop is active, TARGET returns the “Drive Running” bit. (Pr 10.02).
11	INTERNAL LIMIT ACTIVE	Set if <b>vl_velocity_demand</b> goes outside the limits specified in <b>vl_velocity_min_max_amount</b> .
12-15	Reserved	

Table 12.78 shows the values of **statusword** in each state. Bits marked X are irrelevant for that state, and other combinations are not allowed.

**Table 12.78 statusword value**

State	SWITCH ON DISABLED	QUICK STOP	FAULT	OPERATION ENABLED	SWITCHED ON	READY TO SWITCH ON
NOT READY TO SWITCH ON	0	X	0	0	0	0
SWITCH ON DISABLED	1	X	0	0	0	0
READY TO SWITCH ON	0	1	0	0	0	1
SWITCHED ON	0	1	0	0	1	1
OPERATION ENABLED	0	1	0	1	1	1
FAULT	0	X	1	1	1	1
FAULT REACTION ACTIVE	0	X	1	1	1	1
QUICK STOP ACTIVE	0	0	0	1	1	1

## 12.15.10 Shutdown option code

<b>Index</b>	0x605B	<b>Object code</b>	VAR	<b>Access</b>	RW
<b>Sub-index</b>	0	<b>Data type</b>	INTEGER16	<b>PDO mapping</b>	No
<b>Default</b>	0	<b>Units</b>	None		

The **shutdown\_option\_code** parameter determines what action should be taken if there is a transition from OPERATION ENABLE to READY TO SWITCH ON, state transition 8. Refer to the manufacturer specific option codes in Table 12.82 on page 145 for full details of all stopping modes available. Ramps must be enabled (Pr 2.02 = ON or 1) for the ramp functions to work correctly.

**Table 12.79 shutdown\_option\_code codes**

Value	Action	Parameter settings	Description
0	Disable drive function	Pr 6.01 = 0	Select coast stop.
1	Slow down on slow down ramp, then disable drive function	Pr 6.01 = 1 Pr 2.20 = 2 Pr 2.04 = 1	Select ramp stop. Select ramp Pr 2.22. Select standard ramp with normal. motor voltage.

## 12.15.11 Disable operation option code

<b>Index</b>	0x605C	<b>Object code</b>	VAR	<b>Access</b>	RW
<b>Sub-index</b>	0	<b>Data type</b>	INTEGER16	<b>PDO mapping</b>	No
<b>Default</b>	1	<b>Units</b>	None		

The **disable\_operation\_option\_code** parameter determines what action should be taken if there is a transition from OPERATION ENABLE to SWITCHED ON, state transition 5. Refer to the manufacturer specific option codes in Table 12.82 on page 145 for full details of all stopping modes available. Ramps must be enabled (Pr 2.02 = ON or 1) for the ramp functions to work correctly.

**Table 12.80 disable\_operation\_option\_code codes**

Value	Action	Parameter settings	Description
0	Disable drive function	Pr 6.01 = 0	Select coast stop.
1	Slow down on slow down ramp, then disable drive function	Pr 6.01 = 1 Pr 2.20 = 2 Pr 2.04 = 1	Select ramp stop. Select ramp Pr 2.22. Select standard ramp with normal. motor voltage.

## 12.15.12 Quick stop option code

<b>Index</b>	0x605A	<b>Object code</b>	VAR	<b>Access</b>	RW
<b>Sub-index</b>	0	<b>Data type</b>	INTEGER16	<b>PDO mapping</b>	No
<b>Default</b>	2	<b>Units</b>	None		

The **quick\_stop\_option\_code** parameter determines what action should be taken if the quick stop function is executed. Ramps must be enabled (Pr **2.02** = ON or 1) for the ramp functions to work correctly.

**Table 12.81 quick\_stop\_option\_code codes**

Value	Action	Parameter settings	Description
0	Disable drive function	Pr <b>6.01</b> = 0	Select coast stop.
1	Slow down on slow down ramp	Pr <b>6.01</b> = 1 Pr <b>2.20</b> = 2 Pr <b>2.04</b> = 1	Select ramp stop. Select ramp Pr <b>2.22</b> . Select standard ramp with normal motor voltage.
2	Slow down on quick stop ramp	Pr <b>6.01</b> = 1 Pr <b>2.20</b> = 3 Pr <b>2.04</b> = 0	Select ramp stop. Select ramp Pr <b>2.23</b> . Select fast ramp.
3	Not supported		
4			
5	Slow down on slow down ramp and stay in quick-stop	Pr <b>6.01</b> = 1 Pr <b>2.20</b> = 2 Pr <b>2.04</b> = 1	As 1 with stay in quick-stop.
6	Slow down on quick stop ramp and stay in quick-stop	Pr <b>6.01</b> = 1 Pr <b>2.20</b> = 3 Pr <b>2.04</b> = 0	As 2 with stay in quick-stop.
7	Not supported		
8			

**NOTE** Options 9 to 32767 are all reserved for possible future use.

Some manufacturer specific options are also available. These allow the various ramp modes implemented in the Unidrive SP to be used.

**Table 12.82 Manufacturer specific quick\_stop\_option\_code codes**

Value	Action	Parameter settings	Description
-1	Slow down on slow down ramp with timed DC injection	Pr <b>6.01</b> = 2 Pr <b>2.20</b> = 2 Pr <b>2.04</b> = 1	Select ramp stop with timed DC injection. Select ramp Pr <b>2.22</b> . Select standard ramp with normal motor voltage.
-2	Slow down on quick stop ramp with timed DC injection	Pr <b>6.01</b> = 2 Pr <b>2.20</b> = 3 Pr <b>2.04</b> = 0	Select ramp stop with timed DC injection. Select ramp Pr <b>2.23</b> . Select fast ramp.
-3	Slow down on slow down ramp with high motor voltage	Pr <b>6.01</b> = 1 Pr <b>2.20</b> = 2 Pr <b>2.04</b> = 2	Select ramp stop. Select ramp Pr <b>2.22</b> . Select standard ramp with high motor voltage.
-4	Slow down on slow down ramp with high motor voltage and timed dc injection	Pr <b>6.01</b> = 2 Pr <b>2.20</b> = 2 Pr <b>2.04</b> = 2	Select ramp stop with timed DC injection. Select ramp Pr <b>2.22</b> . Select standard ramp with high motor voltage.
-5	Injection braking stop with detection of zero speed	Pr <b>6.01</b> = 3	Select injection braking stop.

**Table 12.82 Manufacturer specific *quick\_stop\_option\_code* codes**

Value	Action	Parameter settings	Description
-6	Timed injection braking stop	Pr 6.01 = 4	Select timed injection braking stop.
-7 to -10	Reserved		
-11	As -1 with stay in quick stop	Pr 6.01 = 2 Pr 2.20 = 2 Pr 2.04 = 1	Select ramp stop with timed DC injection. Select ramp Pr 2.22. Select standard ramp with normal motor voltage.
-12	As -2 with stay in quick stop	Pr 6.01 = 2 Pr 2.20 = 3 Pr 2.04 = 0	Select ramp stop with timed DC injection. Select ramp Pr 2.23. Select fast ramp.
-13	As -3 with stay in quick stop	Pr 6.01 = 1 Pr 2.20 = 2 Pr 2.04 = 2	Select ramp stop. Select ramp Pr 2.22. Select standard ramp with high motor voltage.
-14	As -4 with stay in quick stop	Pr 6.01 = 2 Pr 2.20 = 2 Pr 2.04 = 2	Select ramp stop with timed DC injection. Select ramp Pr 2.22. Select standard ramp with high motor voltage.
-15	As -5 with stay in quick stop	Pr 6.01 = 3	Select injection braking stop.
-16	As -6 with stay in quick stop	Pr 6.01 = 4	Select timed injection braking stop.

Options -7 to -10, and -17 to -32768 are all reserved for possible future use.

### 12.15.13 Modes of operation

Index	0x6060	Object code	VAR	Access	WO
Sub-index	0	Data type	INTEGER8	PDO mapping	Yes
Default	N/A	Units	None		

The ***modes\_of\_operation*** parameter selects the internal profile that should be used. SM-CANopen supports velocity mode and profile torque mode. SM-CANopen profiles must be enabled by setting Pr MM.37 to 1 (ON) (see section 12.15.1 *Enable DSP402 device profiles* on page 137).

**Table 12.83 *modes\_of\_operation* codes**

Value	Action
-1	No profile enabled
0	Reserved
1	Not supported
2	Velocity mode
3	Not supported
4	Torque profile mode
5 - 7	Not supported

### 12.15.14 Modes of operation display

Index	0x6061	Object code	VAR	Access	RO
Sub-index	0	Data type	INTEGER8	PDO mapping	Yes
Default	N/A	Units	None		

The ***modes\_of\_operation\_display*** parameter shows the currently selected profile. See section 12.83 *modes\_of\_operation* codes on page 146.

## 12.15.15 Profile torque mode

Table 12.84 shows a summary of all supported objects of the profile torque mode. Profile torque mode must be enabled by setting *modes\_of\_operation* to 4 (see section 12.15.13 *Modes of operation* on page 146).

**Table 12.84 Profile torque mode supported objects**

Index	Object	Name	Type	Access	PDO mapping
0x6071	VAR	<i>target_torque</i>	INTEGER16	RW	Yes
0x6077	VAR	<i>torque_actual_value</i>	INTEGER16	RO	Yes
0x6087	VAR	<i>torque_slope</i>	UNSIGNED32	RW	Yes
0x6088	VAR	<i>torque_profile_type</i>	INTEGER16	RW	Yes

**Figure 12-4 Profile torque mode objects supported by SM-CANopen**

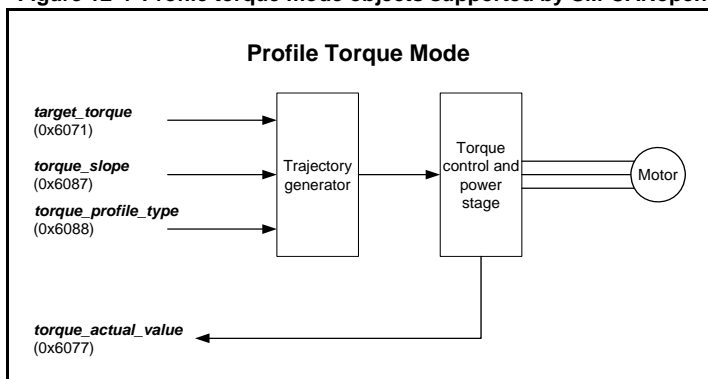

## 12.15.16 Target torque

<b>Index</b>	0x6071	<b>Object code</b>	VAR	<b>Access</b>	RW
<b>Sub-index</b>	0	<b>Data type</b>	INTEGER16	<b>PDO mapping</b>	Yes
<b>Default</b>	0	<b>Units</b>	per thousand of rated torque		

*target\_torque* is the input value for the torque controller. This object is multiplied by 10 and written directly to Pr 4.08 when *controlword* is in the power enabled group of states. Refer to Figure 12-3 on page 141.

## 12.15.17 Torque actual value

<b>Index</b>	0x6077	<b>Object code</b>	VAR	<b>Access</b>	RO
<b>Sub-index</b>	0	<b>Data type</b>	INTEGER16	<b>PDO mapping</b>	Yes
<b>Default</b>	0	<b>Units</b>	per thousand rated current		

*torque\_actual\_value* refers to the instantaneous torque being delivered by the motor. Pr 4.20 is returned in this object.

## 12.15.18 Torque slope

<b>Index</b>	0x6087	<b>Object code</b>	VAR	<b>Access</b>	RW
<b>Sub-index</b>	0	<b>Data type</b>	UNSIGNED32	<b>PDO mapping</b>	Yes
<b>Default</b>	0	<b>Units</b>	per thousand of rated torque per second		

**torque\_slope** describes the maximum rate of change of torque permitted. When a change in **target\_torque** is seen, SM-CANopen will apply a ramp to the torque reference before updating the torque reference parameter, Pr 4.08.

## 12.15.19 Torque profile type

<b>Index</b>	0x6088	<b>Object code</b>	VAR	<b>Access</b>	RW
<b>Sub-index</b>	0	<b>Data type</b>	INTEGER16	<b>PDO mapping</b>	Yes
<b>Default</b>	0	<b>Units</b>	None		

The **torque\_profile\_type** is used to select the type of torque profile used to perform a torque change. Only linear ramps are supported.

**Table 12.85 torque\_profile\_type codes**

<b>Profile code</b>	<b>Profile type</b>
0	Linear ramp (trapezoidal profile)
1	Not supported

## 12.15.20 Velocity mode objects

Table 12.86 shows a summary of all supported objects of the velocity mode. Velocity mode must be enabled by setting the **modes\_of\_operation** object to 2 (see section 12.15.13 *Modes of operation* on page 146).

**Table 12.86 Velocity mode supported objects**

Index	Object	Name	Type	Access	PDO mapping
0x6042	VAR	<i>vl_target_velocity</i>	INTEGER16	RW	Yes
0x6043	VAR	<i>vl_velocity_demand</i>	INTEGER16	RO	Yes
0x6044	VAR	<i>vl_control_effort</i>	INTEGER16	RO	Yes
0x6046	ARRAY	<i>vl_velocity_min_max_amount</i>	UNSIGNED32	RW	Yes
0x6048	RECORD	<i>vl_velocity_acceleration</i>	RAMP	RW	Yes
0x6049	RECORD	<i>vl_velocity_deceleration</i>	RAMP	RW	Yes
0x604C	ARRAY	<i>vl_dimension_factor</i>	INTEGER32	RW	Yes

**Figure 12-5 Velocity mode objects supported by SM-CANopen**

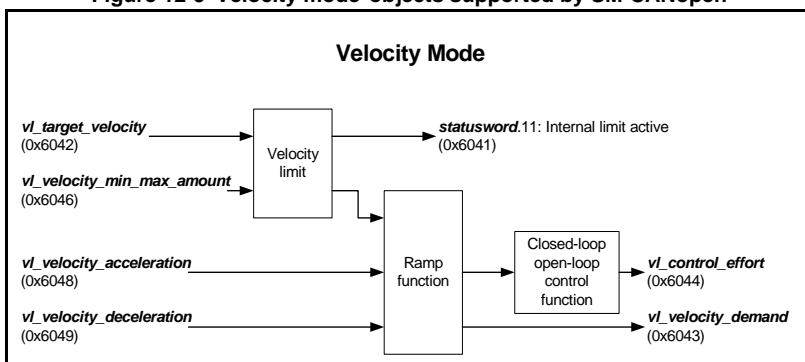

**Table 12.87 vl\_target\_velocity**

<b>Index</b>	0x6042	<b>Object code</b>	VAR	<b>Access</b>	RW
<b>Sub-index</b>	0	<b>Data type</b>	INTEGER16	<b>PDO mapping</b>	Yes
<b>Default</b>	0	<b>Units</b>	rpm		

**vl\_target\_velocity** is the required velocity of the system and is written to Pr 1.21. The units of **vl\_target\_velocity** are rpm, and range from –32768 to +32767.

## 12.15.21VI target velocity

Figure 12-6 *vl\_target\_velocity*

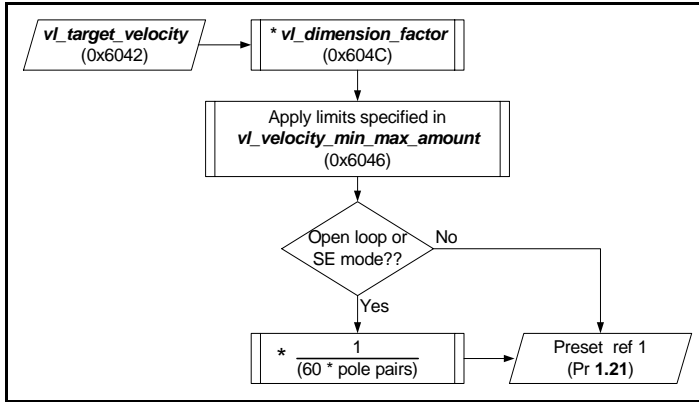

## 12.15.22VI velocity demand

Index	0x6043	Object code	VAR	Access	RO
Sub-index	0	Data type	INTEGER16	PDO mapping	Yes
Default	N/A	Units	rpm		

*vl\_velocity\_demand* is the instantaneous velocity provided by the ramp function, is sourced from Pr 2.01. This object is scaled to the units of *vl\_target\_velocity* and ranges from -32768 to +32767 rpm.

Figure 12-7 *vl\_velocity\_demand*

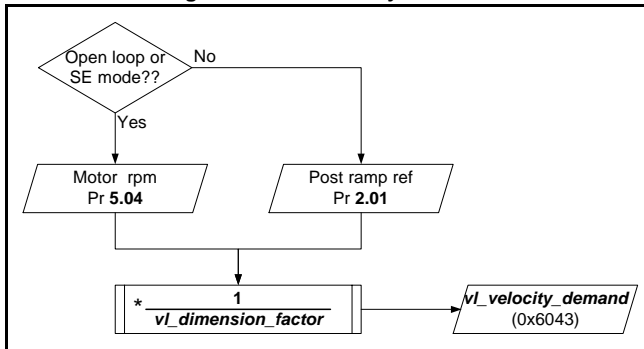

## 12.15.23VI control effort

Index	0x6044	Object code	VAR	Access	RO
Sub-index	0	Data type	INTEGER16	PDO mapping	Yes
Default	N/A	Units	rpm		

*vl\_control\_effort* is the velocity of the motor spindle or load and scaled to the units of *vl\_target\_velocity*. The value ranges from -32768 to +32767.

Figure 12-8 *vl\_control\_effort*

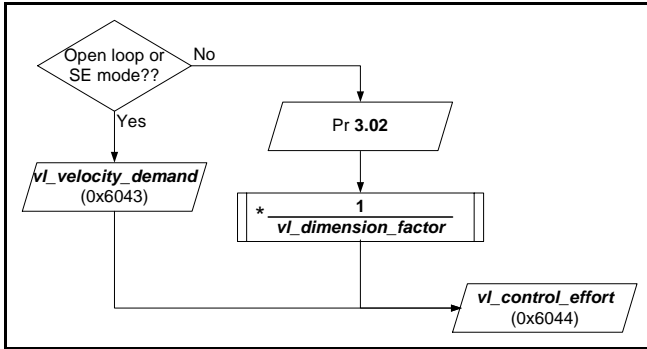

### 12.15.24Vl velocity min max amount

<b>Index</b>	0x6046	<b>Object Type</b>	ARRAY
<b>Elements</b>	2		

***vl\_velocity\_min\_max\_amount*** specifies minimum and maximum clamp values that must be applied to the calculated velocity value, before it is written to the drive. The minimum clamp value is checked first, followed by the maximum clamp value.

#### ***vl\_velocity\_min\_amount***

<b>Index</b>	0x6046	<b>Object code</b>	VAR	<b>Access</b>	RW
<b>Sub-index</b>	1	<b>Data type</b>	UNSIGNED32	<b>PDO mapping</b>	Yes
<b>Default</b>	0	<b>Units</b>	rpm		

***vl\_velocity\_min\_amount*** specifies the minimum clamp value for the internal velocity calculation. ***vl\_velocity\_min\_amount*** is not mapped to Pr 1.07 as Pr 1.07 is not active when the drive is in bi-polar mode. ***vl\_velocity\_min\_amount*** is limited to 0x7FFFFFFF, as this is the maximum positive value for the INTEGER32 internal velocity calculation. This prevents the minimum speed clamp from being set to an illegal value.

#### ***vl\_velocity\_max\_amount***

<b>Index</b>	0x6046	<b>Object code</b>	VAR	<b>Access</b>	RW
<b>Sub-index</b>	2	<b>Data type</b>	UNSIGNED32	<b>PDO mapping</b>	Yes
<b>Default</b>	Pr 1.06	<b>Units</b>	rpm		

***vl\_velocity\_max\_amount*** specifies the maximum clamp value for the internal velocity calculation. ***vl\_velocity\_max\_amount*** is read from Pr 1.06 during initialisation, but Pr 1.06 will NOT be updated if ***vl\_velocity\_max\_amount*** is subsequently changed. This allows the drive maximum speed clamp to be set higher to allow for possible position recovery or speed overshoot during operation.

Safety Information
Introduction
Mechanical Installation
Electrical Installation
Getting Started
EDS Files
Cyclic Data
Non-Cyclic Data
Control and Status Words
Diagnostics
Advanced Features
CAOpen Reference
Quick Reference
Glossary Of Terms
Index

## 12.15.25VI velocity acceleration

<b>Index</b>	0x6048	<b>Object Type</b>	RECORD
<b>Elements</b>	2		

***vl\_velocity\_acceleration*** specifies the slope of the acceleration ramp. It is calculated by dividing ***delta\_speed*** by ***delta\_time***. By default, ***delta\_speed*** is set to 0, so the acceleration ramp is effectively disabled. ***vl\_velocity\_acceleration*** is converted and written to Pr 2.11 when ***delta\_speed*** or ***delta\_time*** are updated.

**Figure 12-9 *vl\_velocity\_acceleration***

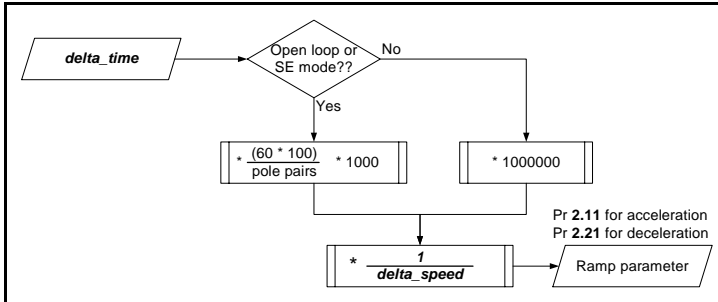

### ***delta\_speed***

<b>Index</b>	0x6048	<b>Object code</b>	VAR	<b>Access</b>	RW
<b>Sub-index</b>	1	<b>Data type</b>	UNSIGNED32	<b>PDO mapping</b>	Yes
<b>Default</b>	0	<b>Units</b>	rpm		

### ***delta\_time***

<b>Index</b>	0x6048	<b>Object code</b>	VAR	<b>Access</b>	RW
<b>Sub-index</b>	2	<b>Data type</b>	UNSIGNED16	<b>PDO mapping</b>	Yes
<b>Default</b>	1	<b>Units</b>	Seconds		

***delta\_time*** is multiplied by a scaling factor and divided by ***delta\_speed*** to calculate the setting for Pr 2.11. When ***delta\_time*** is multiplied by the scaling factor, the interim result must not exceed the maximum range of an UNSIGNED32 value. This equates to 4294 seconds in closed loop or servo mode and 1431 seconds in open loop mode on a 4-pole motor.

## 12.15.26VI velocity deceleration

<b>Index</b>	0x6049	<b>Object Type</b>	RECORD
<b>Elements</b>	2		

***vl\_velocity\_deceleration*** specifies the slope of the deceleration ramp. It is calculated by dividing ***delta\_speed*** by ***delta\_time*** (see Figure 12-9). By default, ***delta\_speed*** is set to 0, so the deceleration ramp is effectively disabled. ***vl\_velocity\_deceleration*** is converted and written to Pr 2.21 when ***delta\_speed*** or ***delta\_time*** are updated.

### ***delta\_speed***

<b>Index</b>	0x6049	<b>Object code</b>	VAR	<b>Access</b>	RW
<b>Sub-index</b>	1	<b>Data type</b>	UNSIGNED32	<b>PDO mapping</b>	Yes
<b>Default</b>	0	<b>Units</b>	rpm		

### ***delta\_time***

<b>Index</b>	0x6049	<b>Object code</b>	VAR	<b>Access</b>	RW
<b>Sub-index</b>	2	<b>Data type</b>	UNSIGNED16	<b>PDO mapping</b>	Yes
<b>Default</b>	1	<b>Units</b>	Seconds		

***delta\_time*** is multiplied by a scaling factor and divided by ***delta\_speed*** to calculate the setting for Pr **2.21**. When ***delta\_time*** is multiplied by the scaling factor, the interim result must not exceed the maximum range of an UNSIGNED32 value. This equates to 4294 secs in closed loop or servo mode, and 1431 secs in open loop mode on a 4-pole motor.

Information	Safety
Introduction	
Mechanical Installation	
Electrical Installation	
Getting Started	
EDS Files	
Cyclic Data	
Non-Cyclic Data	
Control and Status Words	
Diagnostics	
Advanced Features	
<b>CANopen Reference</b>	
Quick Reference	
Glossary Of Terms	
Index	

# 13 Quick Reference

## 13.1 Drive menu parameter reference

Table 13.1 shows every parameter available in the drive for configuring the SM-CANopen, plus a cross-reference to the section in this manual where more information can be found.

**Table 13.1 SM-CANopen parameter reference**

Slot	Default	Cross Reference	Description
Pr MM.01	408	Section 10.1 on page 71	Module ID code
Pr MM.02	----	Section 10.2 on page 71	Major firmware version
Pr MM.03	0	Section 5.1 on page 26	Node address
Pr MM.04	2	Section 5.2 on page 26	Data rate
Pr MM.05	4	Section 5.9 on page 41	Data format
Pr MM.06	----	Section 10.5 on page 72	Operating status
Pr MM.07	200	Section 11.1 on page 78	Network loss trip timeout
Pr MM.08	ON (1)	Section 11.2 on page 79	Data endian format
Pr MM.09	OFF (0)	Section 11.7 on page 83	Direct data mapping enable
Pr MM.10	1040	Section 12.10 on page 127 & Chapter 5 <i>Getting Started</i> on page 25	TxPDOA channel 0 mapping
Pr MM.11	201		TxPDOA channel 1 mapping
Pr MM.12	0		TxPDOA channel 2 mapping
Pr MM.13	0		TxPDOA channel 3 mapping
Pr MM.14	0		Reserved
Pr MM.15	0		
Pr MM.16	0		
Pr MM.17	0		
Pr MM.18	0		
Pr MM.19	0		
Pr MM.20	642	Section 12.8 on page 121 & Chapter 5 <i>Getting Started</i> on page 25	RxPDOA channel 0 mapping
Pr MM.21	121		RxPDOA channel 1 mapping
Pr MM.22	0		RxPDOA channel 2 mapping
Pr MM.23	0		RxPDOA channel 3 mapping
Pr MM.24	0		Reserved
Pr MM.25	0		
Pr MM.26	0		
Pr MM.27	0		
Pr MM.28	0		
Pr MM.29	0		
Pr MM.30	OFF (0)	Section 5.15 on page 44	Restore SM-CANopen defaults
Pr MM.31	OFF (0)	Section 5.14 on page 43	Store to SM-CANopen FLASH memory
Pr MM.32	OFF (0)	Section 5.12 on page 43	Reset SM-CANopen
Pr MM.33	OFF (0)	Section 5.16 on page 45	Restore previous configuration from SM-CANopen FLASH memory
Pr MM.34	OFF (0)	Section 11.8 on page 84	Cyclic data compression enable
Pr MM.35	----	Section 12.3.12 on page 113	Serial number
Pr MM.36	OFF (0)	Section 12.8.3 on page 122	PDO EVENT trigger

**Table 13.1 SM-CANopen parameter reference**

Slot	Default	Cross Reference	Description
Pr <b>MM.37</b>	OFF (0)	Section 12.15.1 on page 137	Enable DSP402 profile
Pr <b>MM.38</b>	OFF (0)		Reserved
Pr <b>MM.39</b>	4	Section 11.10 on page 85	TxPDO length
Pr <b>MM.40</b>	4		RxPDO length
Pr <b>MM.41</b>	0	Section 12.8.3 on page 122	TxPDO transmission type
Pr <b>MM.42*</b>	0	Section 11.13 on page 88	SM-Applications object priority
Pr <b>MM.43*</b>	0	Section 11.14.3 on page 91	Synchronisation Mode
Pr <b>MM.44*</b>	0	Section 11.14.4 on page 93	Synchronisation Status
Pr <b>MM.45*</b>	0	Section 11.14.5 on page 93	Synchronisation Period
Pr <b>MM.46*</b>	0	Section 11.16.1 on page 99	Increments on PDO Transfer Cycle
Pr <b>MM.47</b>	0		Reserved
Pr <b>MM.48</b>	0		
Pr <b>MM.49</b>	----	Section 10.6 on page 73	SM-CANopen mapping status
Pr <b>MM.50</b>	----	Section 10.7 on page 76	SM-CANopen error codes
Pr <b>MM.51</b>	----	Section 10.2 on page 71	Minor firmware version

\* Not supported by Commander SK or SX.

## 13.2 Virtual parameter reference

Table 13.2 shows every virtual parameter available in the SM-CANopen, plus a cross-reference to the section in this manual where more information can be found. Virtual parameters can only be accessed from the CANopen network using non-cyclic communications.

**Table 13.2 SM-CANopen virtual parameter reference**

Slot 1	Default	Cross reference	Description
Pr <b>61.01</b>	----	----	Drive Pr <b>MM.00</b> access
Pr <b>61.35</b>	----	Section 12.3.12 on page 113	Serial number
Pr <b>61.40</b>	0	Section 11.9 on page 84	SM-Applications event task trigger (lowest slot)
Pr <b>61.41</b>	0		SM-Applications event task trigger (slot 1)
Pr <b>61.42</b>	0		SM-Applications event task trigger (slot 2)
Pr <b>61.43</b>	0		SM-Applications event task trigger (slot 3)
Pr <b>61.50</b>	0	Section 8.2 on page 56	CT Single Word (Mode 1) non-cyclic data mapping parameter

## 13.3 Object reference

Table 13.3 shows all supported objects available within SM-CANopen. Plus a cross reference to the section in this manual containing more information on the object.

**Table 13.3 SM-CANopen object reference**

Index	Name And Link	Description	Link
0x1000	<b>Device Type</b>	Indicates the current configuration of the Unidrive SP and SM-CANopen	Section 12.3 on page 107
0x1001	<b>Error Register</b>	Used by the SM-CANopen to indicate that an error has occurred.	Section 12.3.1 on page 108
0x1002	<b>Manufacturer Status Register</b>	Mapped directly to the status word (Pr 10.40) in the Unidrive SP.	Section 12.3.2 on page 108
0x1003	<b>Pre-Defined Error</b>	Returns 32-bit error code containing data from the last 4 emergency messages that were sent.	Section 12.3.3 on page 108
0x1005	<b>COB-ID SYNC</b>	Defines the COB-ID that will be used for the synchronisation (SYNC) object.	Section 12.3.4 on page 109
0x1008	<b>Manufacturer Device Name</b>	Returns the string "SM-CANopen" to indicate the product name.	Section 12.3.5 on page 110
0x1009	<b>Manufacturer Hardware Version</b>	Returns the string "UT77" to indicate the product hardware.	Section 12.3.6 on page 110
0x100A	<b>Manufacturer Software Version</b>	Returns a string to indicate the firmware version installed.	Section 12.3.7 on page 110
0x1010	<b>Store parameters</b>	This object is used to save the communication parameters.	Section 12.3.8 on page 110
0x1011	<b>Restore default values</b>	This object is used to restore default values.	Section 12.3.9 on page 111
0x1014	<b>COB-ID EMCY</b>	Defines the COB-ID to be used for the emergency object.	Section 12.3.10 on page 112
0x1017	<b>Producer Heartbeat Time</b>	The "heartbeat protocol" is a node protection system or error control service.	Section 12.3.11 on page 112
0x1018	<b>Identity Object</b>	Returns general information about the SM-CANopen.	Section 12.3.12 on page 113
0x1400 0x15FF	<b>RxPDO communication parameters</b>	Communication information for RxPDO	Section 12.6 on page 117
0x1600 0x17FF	<b>RxPDO mapping parameters</b>	Mapping information for RxPDO	Section 12.7 on page 119
0x1800 0x19FF	<b>TxPDO communication parameters</b>	Communication information for TxPDO	Section 12.8 on page 121
0x1A00 0x1BFF	<b>TxPDO mapping parameters</b>	Mapping information for TxPDO	Section 12.9 on page 124
0x2800	<b>RxPDO number configuration</b>	This object is used for configuring the available RxPDOs.	Section 12.5.1 on page 115
0x2801	<b>TxPDO number configuration</b>	This object is used for configuring the available TxPDOs.	Section 12.5.2 on page 115

---

# 14 Glossary Of Terms

---

**Address:** This is the unique network identification given to a networked device to allow communication on a network. When a device sends or receives data the address is used to determine the source and the destination of the message.

**Bit:** A binary digit, this may have the value of 1 or 0.

**Block mapping:** A method of mapping a range of consecutive parameters using only two ascending parameters. This means that by using two mapping parameters, up to 32 consecutive mappings may be made. See section 11.9 *Unidrive SP: event task trigger in SM-Applications* on page 84 for more information.

**Byte:** A collection of 8 binary digits that collectively store a value. This may be signed or unsigned.

**CAN:** The base network used for CANopen. The CANopen module does not support CAN commands.

**CANopen:** Builds on the basic CAN protocol by offering higher level functionality.

**Casting:** The process of changing between data sizes without changing the value represented, e.g. changing from 16 bit to 32 bit.

**Compression:** By default SM-CANopen transmits values as 32 bits on the network. It is possible by using compression to reduce the number of bits transmitted when sending 16 bit (or smaller) values on the network to 16 bit (32 bit values will still be transmitted as 32 bit values). This has the advantage of reducing the volume of traffic on the network and allowing more parameters to be mapped within SM-CANopen.

**Consistency:** Describes how data is transmitted between nodes on the network. If data is consistent it is transmitted from node to node as a single entity. Thus preventing data corruption where multiple bytes are transmitted or received individually.

**Control word:** A collection of binary digits that are used to control the drive. Features typically include directional controls, run controls and other similar functions.

**CT Single Word non-cyclic:** *see mode 1 non-cyclic in this section.*

**Cyclic data:** This consists of values that are sent at regular or cyclic intervals across the network. A typical use of cyclic data would be the transmission of a speed reference or a control word.

**Data format:** Determines the quantity and function of the data sent and received across the network.

**Data rate:** Determines the communication speed of the network, the higher the value the more data can be sent across the network in the same time period.

Safety Information
Introduction
Mechanical Installation
Electrical Installation
Getting Started
EPS Files
Cyclic Data
Non-Cyclic Data
Control and Status Words
Diagnostics
Advanced Features
CANopen Reference
Quick Reference
Glossary Of Terms
Index

**Device:** A piece of equipment connected to a network, this may be any type of equipment including repeaters, hubs, masters or slaves.

**Object Dictionary:** A collection of the objects that are supported by the product.

**Direct data mapping:** Data is sent directly to the mapping parameters in the drive rather than the parameters redirecting the data to another parameter.

**Double word:** A 32 bit word, this may be signed or unsigned.

**Earthing:** Describes the electrical safety or screening connections for the module.

**Endian format:** When a value uses more than 8 bits to represent it's value it needs to be sent in sets of 8 bits (bytes) across the network, the endian format determines the order the bytes that constitute the whole value are transmitted.

**Event task:** A special way to use a message or change of state to trigger a software routine.

**Long word:** A 32bit data word that may be signed or unsigned.

**Mapping:** The process of linking CANopen values to parameters within the drive.

**Master:** The controlling device on the network, generally this will include programming features.

**Mode 1 non-cyclic:** A method of sending non-cyclic data using a single word.

**Network loss trip:** A method to determine when a node has lost communication with the master.

**Node:** A device on the network. This may be either a device such as a drive or part of the network such as a repeater.

**Non-cyclic data:** Data that is requested or sent by the master as required. This is not sent on a regular basis and generally allows access to any parameter. This is useful for occasional changes or configuration purposes.

**PDO:** Process Data Object. This is the method that CANopen uses to transmit and receive cyclic data.

**Poll rate:** The rate at which cyclic data is sent and received on the network.

**PPO 4 Word non-cyclic mode:** see Mode 2 non-cyclic in this section. This is not the same as PPO4 mode.

**Response ID:** The response code of the message received when using PPO4 word non-cyclic communication.

**Scan rate:** See Poll rate in this section.

**Screening:** A connection to provide additional immunity to noise used on a network cable.

**SDO:** Service Data Object. These provide non-cyclic access to the CANopen object dictionary in each slave.

**Segment:** An electrically separate part of the network. Each segment requires correct termination to ensure reliable operation. Due to electrical limitations the maximum number of devices on a segment is limited to 32.

**Slave:** A device on the CANopen network such as a drive or sensor. A slave device will only respond to messages from a master.

**Status word:** A value that denotes the status of the drive. Each bit within the word will have a specific meaning.

**Stuff Bits:** Stuff bits are used by CANopen to ensure that each CANopen device does not transmit a long stream of consecutive 1s or 0s.

**Telegram:** A message used within mode 1 non-cyclic data communication. This term is sometimes used to represent a generic message on the network.

**Termination:** This is used at both ends of a network segment to prevent reflections and reduce noise.

**Watchdog:** A method used to determine if a communication system is healthy. A typical watchdog scheme uses a handshaking system to check both the master and slave are participating in communications.

**Word:** A collection of 16 binary digits.

Safety Information
Introduction
Mechanical Installation
Electrical Installation
Getting Started
EDS Files
Cyclic Data
Non-Cyclic Data
Control and Status Words
Diagnostics
Advanced Features
CANopen Reference
Quick Reference
Glossary Of Terms
Index

---

# Index

---

## Numerics

16-bit parameter access ..... 57

## A

Above set speed ..... 69

Activate bit timing ..... 132

ASSOCIATEINTOPCOMMS ..... 87

At speed ..... 69

Avoiding block mapping ..... 83

## B

Back-up - parameters to SM-CANopen FLASH memory ..... 44

Back-up power supply ..... 23

Basic data types ..... 106

Below set speed ..... 69

Blank mapping parameters ..... 53

Block ..... 82

Block mapping ..... 81

Byte order ..... 79

## C

Cable length ..... 24

Cautions ..... 6

Changing data rate ..... 131

Changing PDO mapping parameters ..... 52

COB-ID EMCY ..... 112

COB-ID SYNC ..... 109

Communication profile objects ..... 106, 156

Complete parameter reference ..... 154

Compliance with regulations ..... 7

Configuration error ..... 73

Configure bit timing ..... 131

Configure node-ID ..... 131

Conformance certificate ..... 11

Connections - cable shield ..... 23

Control and status words ..... 66

Control word bit functions ..... 67

Conversion factors ..... 137

Current limit ..... 69

Cyclic data ..... 49

Cyclic data compression ..... 50, 84

## D

Data size ..... 50

Default COB-IDs and transmission type ..... 41

Default parameters - restore ..... 111

Device profiles ..... 137

Diagnostics ..... 70

DINT ..... 99

Direct data mapping ..... 83

DPL function call .....	86
Drive active .....	69
Drive healthy .....	69
Dual SM-Applications fitted .....	81
Dynamic brake active .....	69
Dynamic brake alarm .....	69
<b>E</b>	
EDS files .....	47
Electrical safety .....	6
Emergency error codes .....	135
Emergency object .....	134
Emergency object state .....	135
Emergency object state transitions .....	136
Enable DSP402 device profiles .....	137
Endian format .....	79
Environmental limits .....	7
Equipment malfunction .....	6
Error code .....	76
Error register .....	108, 136
Event task reason codes .....	85
Event task trigger in SM-Applications .....	84
Example function call .....	88
<b>F</b>	
Flexible PDO numbering .....	114
<b>G</b>	
General information .....	2
Generating emergency objects from DPL .....	136
Getting started .....	25
Glossary of terms .....	157
<b>H</b>	
Hardware enable .....	66
<b>I</b>	
Identity object .....	113
Internal interrupts .....	100
Inter-option communication timing .....	79
<b>L</b>	
Layer setting services (LSS) .....	129
Linking object dictionary entries to DPL program variables .....	86
Local solutions module parameter access .....	80
<b>M</b>	
Maintaining DPL variables .....	88
Manufacturer device name .....	110
Manufacturer hardware version .....	110
Manufacturer software version .....	110
Manufacturer status register .....	108
Mapping parameter values .....	126
Mapping status .....	73
Mapping To SM-Applications parameters .....	80

Safety Information
Introduction
Mechanical Installation
Electrical Installation
Getting Started
EDS Files
Cyclic Data
Non-Cyclic Data
Control and Status Words
Diagnostics
Advanced Features
CANopen Reference
Quick Reference
Glossary Of Terms
<b>Index</b>

Mode 1 - CT single word mode .....	56
Motor .....	7
<b>N</b>	
Network length .....	24
Network load .....	104
Network loss trip .....	78
Network management objects (NMT) .....	127
NMT commands .....	128
Node address .....	26
Non-cyclic data .....	54
Notes .....	6
<b>O</b>	
Object association rules .....	87
Operating states .....	112
Operating status .....	42, 72
Optimisation .....	88
Output channel .....	102
<b>P</b>	
Parameter data object mapping .....	137
Parameters - adjusting .....	7
Parameters - complete reference .....	154
PDO counter .....	86
PDO data mapping errors .....	52
PDO1 2 channels (default) .....	51
PDO1 with 1 channel and CT single word non-cyclic data .....	52
PDOA length .....	85
Position control with interpolation .....	97
Position control without interpolation .....	94
Pre-defined error field .....	108
Process data object (PDO) .....	49
Producer heartbeat time .....	112
Profile torque mode .....	147
Profiles .....	52
<b>Q</b>	
Quick reference .....	154
<b>R</b>	
Regenerating .....	69
RMINT, RMINT_1MS and RMINT_POS .....	100
Running at or below minimum speed .....	69
RxPDO COB-ID .....	117
RxPDO communication parameters .....	117
RxPDO event timer .....	119
RxPDO inhibit time .....	119
RxPDO mapping parameters .....	119
RxPDO transmission type .....	118
<b>S</b>	
Safety of personnel .....	6
SDO abort codes .....	55
Secure disable .....	6

Select product code .....	130
Select revision number .....	130
Select serial number .....	130
Select vendor ID .....	130
Service data object (SDO) .....	54
Set-up flow chart .....	30
Set-up using non-cyclic data .....	65
Slave RMINT accuracy .....	104
SM-CANOpen timing .....	95
Spurs .....	24
Status word .....	68
Status word bit functions .....	69
Switch mode global .....	129
Switch mode selective .....	130
SYNC absolute timing accuracy .....	103
SYNC jitter .....	104
Synchronisation period .....	93
Synchronisation status .....	93
Synchronising Unidrive SP via the CANOpen network .....	94
<b>T</b>	
target_torque .....	147
Timing and data transfer consistency .....	99
torque_actual_value .....	147
torque_profile_type .....	148
torque_slope .....	148
TxPDO COB-ID .....	122
TxPDO communication parameters .....	121
TxPDO inhibit time .....	123
TxPDO mapping parameters .....	124
TxPDO number configuration .....	115
TxPDO transmission type .....	122
<b>U</b>	
Unused PDO data channels .....	52
<b>V</b>	
Velocity mode objects .....	149
Virtual parameter reference .....	155
vl_control_effort .....	150
vl_velocity_acceleration .....	152
vl_velocity_deceleration .....	152
vl_velocity_demand .....	150
vl_velocity_min_max_amount .....	151
<b>W</b>	
Warnings .....	6
<b>Z</b>	
Zero speed .....	69

Safety Information
Introduction
Mechanical Installation
Electrical Installation
Getting Started
EDS Files
Cyclic Data
Non-Cyclic Data
Control and Status Words
Diagnostics
Advanced Features
CANOpen Reference
Quick Reference
Glossary Of Terms
Index



**0471-0020-07**