



User Guide

SM-INTERBUS

Solutions Module for
Unidrive SP

Part Number: 0471-0021-02
Issue Number: 2

General Information

The manufacturer accepts no liability for any consequences resulting from inappropriate, negligent or incorrect installation or adjustment of the optional operating parameters of the equipment or from mismatching the variable speed drive (Drive) with the motor.

The contents of this guide are believed to be correct at the time of printing. In the interests of a commitment to a policy of continuous development and improvement, the manufacturer reserves the right to change the specification of the product or its performance, or the contents of this guide, without notice.

All rights reserved. No parts of this guide may be reproduced or transmitted in any form or by any means, electrical or mechanical including photocopying, recording or by an information storage or retrieval system, without permission in writing from the publisher.

Drive software version

The SM-INTERBUS can only be used with Unidrive SP firmware version V1.00.00 and later.

Copyright © 15 May 2003 Control Techniques Drives Ltd.

Issue Code: 2

Hardware: UT74 Issue 00.02

Firmware: V1.00.00

Contents

1	Safety Information	1
1.1	Warnings, Cautions and Notes	1
1.2	Electrical safety - general warning	1
1.3	System design and safety of personnel	1
1.4	Environmental limits	2
1.5	Compliance with regulations	2
1.6	Motor	2
1.7	Adjusting parameters	2
2	Introduction	3
2.1	SM-INTERBUS for Unidrive SP	3
2.2	Product conformance certificate	3
2.3	General specification	3
3	Mechanical Installation	4
3.1	Installing the SM-INTERBUS	4
3.2	Removing The SM-INTERBUS	5
4	Electrical Installation	6
4.1	SM-INTERBUS terminal descriptions	6
4.2	SM-INTERBUS connections	7
4.3	INTERBUS cable	8
4.4	SM-INTERBUS cable shield connections	8
4.5	INTERBUS network termination	8
4.6	Maximum network length	8
5	Getting Started	9
5.1	CTSoft Wizard	9
5.2	SM-INTERBUS node address	10
5.3	SM-INTERBUS data rate	10
5.4	SM-INTERBUS data format	10
5.5	SM-INTERBUS operating status	10
5.6	Resetting the SM-INTERBUS	11
5.7	Reset all Solutions Modules	11
6	Cyclic Data	12
6.1	What is cyclic data?	12
6.2	SM-INTERBUS data formats	12
6.3	Cyclic data mapping errors	15
6.4	Storing SM-INTERBUS configuration parameters	16
6.5	Disabling cyclic data channels	16
7	Control and Status Words	17
7.1	Unidrive SP control word	17
7.2	Unidrive SP status word	20
7.3	Legacy Control Words	22

8	Non-Cyclic Data	23
8.1	Mode 1 - CT Single Word mode	23
8.2	Mode 2 - PPO 4 Word mode	33
8.3	Mode 3 - Peripheral Communications Protocol (V2.0)	40
8.4	SM-INTERBUS set-up using non-cyclic data	42
9	CMD Tool Support Files	43
9.1	INTERBUS CMD tool	43
9.2	SM-INTERBUS CMD tool configuration formats	43
10	Diagnostics	45
10.1	Module ID code	45
10.2	SM-INTERBUS firmware version	45
10.3	SM-INTERBUS node address	46
10.4	SM-INTERBUS data rate	46
10.5	SM-INTERBUS operating status	46
10.6	SM-INTERBUS status LEDs	47
10.7	SM-INTERBUS mapping status	48
10.8	Unidrive SP trip display codes	49
10.9	SM-INTERBUS error codes	50
10.10	SM-INTERBUS serial number	51
11	Advanced Features	52
11.1	SM-INTERBUS network loss trip	52
11.2	Menu 60 - Local Solutions Module parameter access	53
11.3	Mapping To SM-Applications parameters	53
11.4	Block mapping	55
11.5	Direct data mapping	57
11.6	Cyclic data compression	57
11.7	EVENT task trigger in SM-Applications	60
11.8	Unidrive compatible control word	61
11.9	Commander SE compatible control word	62
11.10	Restore SM-INTERBUS defaults	64
11.11	Restore previous SM-INTERBUS configuration	64
12	Quick Reference	66
12.1	Complete parameter reference	66

1 Safety Information

1.1 Warnings, Cautions and Notes



A **Warning** contains information, which is essential for avoiding a safety hazard.



A **Caution** contains information, which is necessary for avoiding a risk of damage to the product or other equipment.

NOTE

A **Note** contains information, which helps to ensure correct operation of the product.

1.2 Electrical safety - general warning

The voltages used in the drive can cause severe electrical shock and/or burns, and could be lethal. Extreme care is necessary at all times when working with or adjacent to the drive. Specific warnings are given at the relevant places in this User Guide.

1.3 System design and safety of personnel

The drive is intended as a component for professional incorporation into complete equipment or a system. If installed incorrectly, the drive may present a safety hazard.

The drive uses high voltages and currents, carries a high level of stored electrical energy, and is used to control equipment which can cause injury.

Close attention is required to the electrical installation and the system design to avoid hazards either in normal operation or in the event of equipment malfunction. System design, installation, commissioning and maintenance must be carried out by personnel who have the necessary training and experience. They must read this safety information and this User Guide carefully.

The STOP and SECURE DISABLE functions of the drive do not isolate dangerous voltages from the output of the drive or from any external option unit. The supply must be disconnected by an approved electrical isolation device before gaining access to the electrical connections.

With the sole exception of the SECURE DISABLE function, none of the drive functions must be used to ensure safety of personnel, i.e. they must not be used for safety-related functions.

Careful consideration must be given to the functions of the drive which might result in a hazard, either through their intended behaviour or through incorrect operation due to a fault. In any application where a malfunction of the drive or its control system could lead to or allow damage, loss or injury, a risk analysis must be carried out, and where necessary, further measures taken to reduce the risk - for example, an over-speed protection device in case of failure of the speed control, or a fail-safe mechanical brake in case of loss of motor braking.

The SECURE DISABLE function has been approved¹ as meeting the requirements of EN954-1 category 3 for the prevention of unexpected starting of the drive. It may be used in a safety-related application. **The system designer is responsible for ensuring that the complete system is safe and designed correctly according to the relevant safety standards.**

¹Independent approval by BIA has been given for sizes 1 to 3.

1.4 Environmental limits

Instructions in the *Unidrive SP User Guide* regarding transport, storage, installation and use of the drive must be complied with, including the specified environmental limits. Drives must not be subjected to excessive physical force.

1.5 Compliance with regulations

The installer is responsible for complying with all relevant regulations, such as national wiring regulations, accident prevention regulations and electromagnetic compatibility (EMC) regulations. Particular attention must be given to the cross-sectional areas of conductors, the selection of fuses or other protection, and protective earth (ground) connections.

The *Unidrive SP User Guide* contains instruction for achieving compliance with specific EMC standards.

Within the European Union, all machinery in which this product is used must comply with the following directives:

98/37/EC: Safety of machinery.

89/336/EEC: Electromagnetic Compatibility.

1.6 Motor

Ensure the motor is installed in accordance with the manufacturer's recommendations. Ensure the motor shaft is not exposed.

Standard squirrel cage induction motors are designed for single speed operation. If it is intended to use the capability of the drive to run a motor at speeds above its designed maximum, it is strongly recommended that the manufacturer is consulted first.

Low speeds may cause the motor to overheat because the cooling fan becomes less effective. The motor should be fitted with a protection thermistor. If necessary, an electric forced vent fan should be used.

The values of the motor parameters set in the drive affect the protection of the motor. The default values in the drive should not be relied upon.

It is essential that the correct value is entered in Pr **0.46** motor rated current. This affects the thermal protection of the motor.

1.7 Adjusting parameters

Some parameters have a profound effect on the operation of the drive. They must not be altered without careful consideration of the impact on the controlled system. Measures must be taken to prevent unwanted changes due to error or tampering.

2 Introduction

NOTE Unidrive SP parameters are denoted in this manual by “Pr **MM.PP**”, where MM refers to the menu number, and PP refers to the parameter number within that menu. Please refer to the Unidrive SP *User Guide* for full parameter definitions.

2.1 SM-INTERBUS for Unidrive SP

The SM-INTERBUS for Unidrive SP is a Solutions Module that can be fitted to any one of the three expansion slots in the Unidrive SP. The SM-INTERBUS uses a 16-bit Processor and communicates at 500 Kbit/s.

Figure 2-1 Unidrive SP Solutions Module

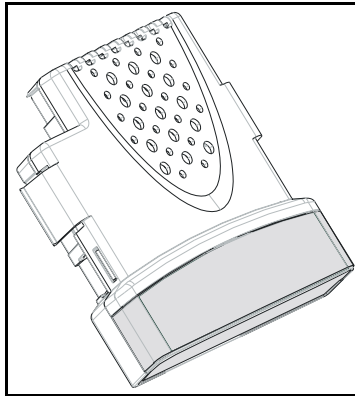

The SM-INTERBUS is powered from the Unidrive SP internal power supply. The Unidrive SP can be connected to a back-up power supply. This keeps the control electronics and options powered up, allowing the SM-INTERBUS to continue communicating with the INTERBUS master controller when the main supply to the Unidrive SP is switched off.

2.2 Product conformance certificate

The SM-INTERBUS has been submitted to the INTERBUS Club to be tested for full INTERBUS Conformance Certification.

2.3 General specification

- 1 to 10 input/output cyclic data words (16-bit) supported
- PCP V2.0, CT Single Word or PPO 4 Word mode non-cyclic data channel (optional)

3 Mechanical Installation



The Unidrive SP must be disconnected from all power supplies before installing or removing the SM-INTERBUS.

3.1 Installing the SM-INTERBUS

- Locate the SM-INTERBUS into the required slot, and press down until it clicks into place.

Figure 3-1 Installing the SM-INTERBUS

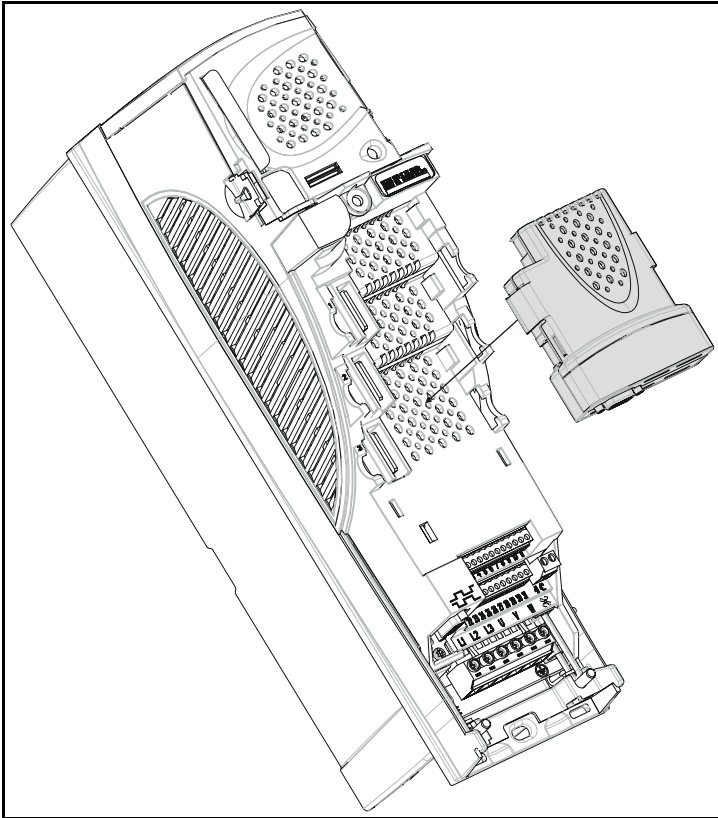

3.2 Removing The SM-INTERBUS

- To remove the SM-INTERBUS from the slot, press both clips inwards (A) and lift it away (B) from the Unidrive SP.

Figure 3-2 Removing the SM-INTERBUS

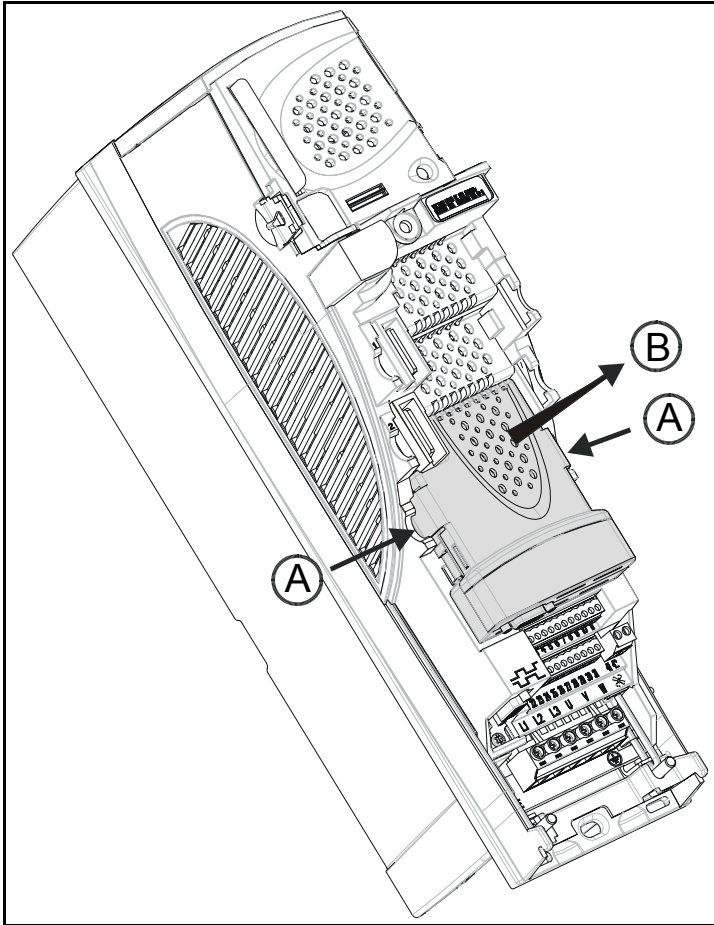

4 Electrical Installation

4.1 SM-INTERBUS terminal descriptions

The SM-INTERBUS has a 9-way male connector for the Remote Bus IN port and a 9-way female connector for the Remote Bus OUT port.

Figure 4-1 SM-INTERBUS - front view

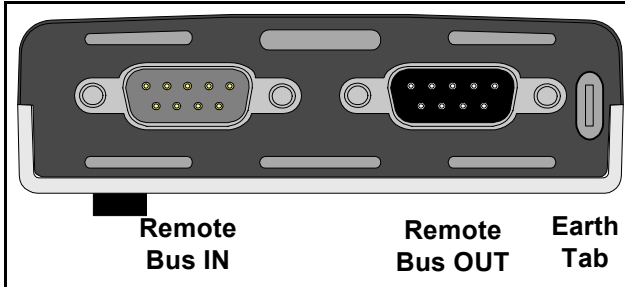

The terminal functions are given in the Table 4.1.

Table 4.1 SM-INTERBUS terminal descriptions

Terminal	Function	Description
IN 1	DO1	Positive Data IN line, connect to DO2
IN 6	/DO1	Negative Data IN line, connect to /DO2
IN 2	DI1	Positive Data OUT line, connect to DI2
IN 7	/DI1	Negative Data OUT line, connect to /DI2
IN 3	0V ISO IN	0V Isolated for Remote Bus IN
IN Shell	Shield	Remote Bus IN Cable Shield
OUT 1	DO2	Positive Data IN line, connect to DO1
OUT 6	/DO2	Negative Data IN line, connect to /DO1
OUT 2	DI2	Positive Data OUT line, connect to DI1
OUT 7	/DI2	Negative Data OUT line, connect to /DI1
OUT 3	0V ISO OUT	0V Isolated for Remote Bus OUT
OUT 5	+5V ISO OUT	+5V Isolated for Remote Bus OUT
OUT 9	RBST	Remote Bus OUT Enable
OUT Shell	Shield	Remote Bus OUT Cable Shield
Ground Tab	Ground	Ground Tab

4.2 SM-INTERBUS connections

The SM-INTERBUS requires in-line D-type connector. At present, Control Techniques are not aware of any company who manufacture an in-line INTERBUS connector with screw terminals that will fit inside the Unidrive SP. All INTERBUS connectors that are currently available have the cable entering the connector at an angle to the D-type connector, and these connectors will not fit inside the Unidrive SP terminal cover.

Figure 4-2 illustrates an INTERBUS connection using standard D-type connectors with solder connections, and a typical D-type housing available from companies such as RS and Farnell.

Figure 4-2 INTERBUS network connections

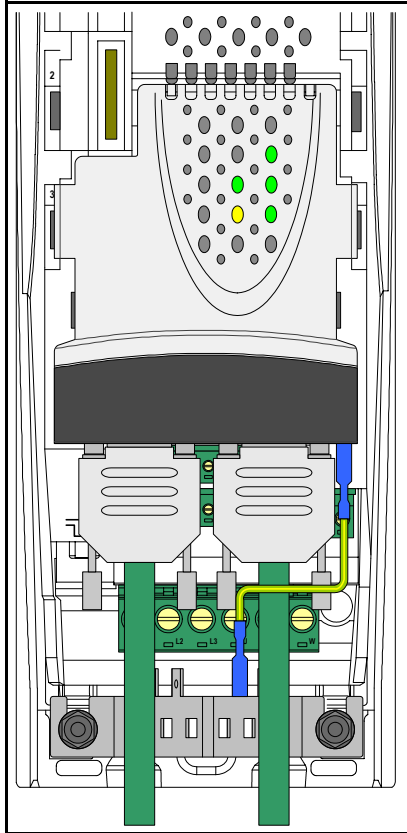

The Ground Tab should be connected to one of the tabs on the Unidrive SP Grounding Bar using a length of 2.5mm² Ground cable with a female push-on crimp connector (6.3mm² * 0.8mm² tab size) fitted at each end. (Blue crimp connectors are suitable for use with 2.5mm² Ground cable.) This link should be kept as short as practically possible, and should NOT be more than 200mm in length.

4.3 INTERBUS cable

INTERBUS cable has three twisted pairs plus overall shielding. The colours normally used on INTERBUS networks are shown in Table 4.2. It is recommended to follow these wiring guidelines as this will make it easier to trace possible wiring errors during system commissioning.

Table 4.2 INTERBUS cable colour codes

Cable	Data Signal	D-type	Description
Green	/DO1, /DO2	6	Negative data OUT line
Yellow	DO1, DO2	1	Positive data OUT line
Pink	/DI1, /DI2	7	Negative data IN line
Grey	DI1, DI2	2	Positive data IN line
Brown	0V ISO IN, 0V ISO OUT	3	0V
White	Not used	---	Not used
Shield	Shield	Shell	Cable shield

INTERBUS cable is specifically designed to carry high frequency signals. Low quality cable will attenuate the signals, and may render the signal unreadable for the other nodes on the network. A list of suppliers approved by the INTERBUS Club is available from the INTERBUS Club web site at www.interbusclub.com.

NOTE

Control Techniques can only guarantee correct and reliable operation of the SM-INTERBUS if all other equipment installed (including the network cable) has been approved by the INTERBUS Club.

4.4 SM-INTERBUS cable shield connections

The Remote Bus IN and Remote Bus OUT cable shields MUST be connected to the shell of the D-type connector. There is no requirement to connect the cable shields to the Unidrive SP Grounding Bar, or directly to Ground at any other point in the INTERBUS network.

4.5 INTERBUS network termination

External termination resistors are not required on INTERBUS networks, as each section of cable is automatically terminated on every INTERBUS node. Ensure that the Ground Tab on the SM-INTERBUS is connected to the Unidrive SP Grounding Bar. (Refer to section 4.2 *SM-INTERBUS connections* on page 7.)

4.6 Maximum network length

The maximum length of cable is 400m between Remote Bus nodes. Hence, the maximum total length of the INTERBUS network depends entirely on the number of nodes connected to the network.

5 Getting Started

Full explanations of the cyclic data functions and supported data formats are given in Chapter 6 *Cyclic Data* on page 12. Non-cyclic data and node configuration using non-cyclic data are described in Chapter 8 *Non-Cyclic Data* on page 23.

NOTE The SM-INTERBUS can only be fitted to a Unidrive SP with firmware V1.00.00 or later.

Unidrive SP has 3 slots available for Solutions Modules, and each slot has a dedicated menu of configuration parameters.

Figure 5-1 Unidrive SP slot arrangement

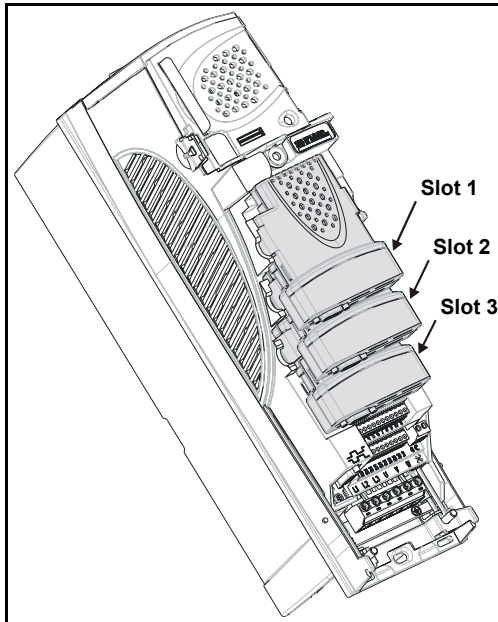

The SM-INTERBUS can be fitted to any slot, and each slot has a corresponding menu of parameters. When referring to a specific parameter for any slot, e.g. ID Code, the parameter will be referred to as Pr **MM.01**.

Table 5.1 Slot Configuration Menu

Slot	Menu
1	Pr 15.PP
2	Pr 16.PP
3	Pr 17.PP

5.1 CTSOft Wizard

CTSOft does not currently have any wizards specified, although it is intended to include wizards at a later date.

5.2 SM-INTERBUS node address

INTERBUS networks do not require a node address to be specified for each device. The physical wiring of the network determines the Communication Reference (CR) that will be assigned to each device.

5.3 SM-INTERBUS data rate

INTERBUS networks operate at a fixed data rate of 500 Kbit/s, so there is no requirement to configure the data rate for the SM-INTERBUS module.

5.4 SM-INTERBUS data format

Name	SM-INTERBUS data format		
Slot 1	Pr 15.05	Default	4
Slot 2	Pr 16.05	Range	0 to 309
Slot 3	Pr 17.05	Access	RO

The default data format is 4 cyclic words. Each cyclic data channel is mapped to a Unidrive SP parameter, with default mappings as shown in the table below.

Table 5.2 Default data mapping

Cyclic word	Data word	Default mapping status
IN channel 0	Word 0, 1	Pr 10.40, status word
IN channel 1	Word 1, 2	Pr 2.01, post-ramp speed reference
OUT channel 0	Word 0, 1	Pr 6.42, control word
OUT channel 1	Word 2, 3	Pr 1.21, digital speed reference 1

Other data formats are also supported. For further details, see section 6.2 *SM-INTERBUS data formats* on page 12.

5.5 SM-INTERBUS operating status

Name	SM-INTERBUS operating status		
Slot 1	Pr 15.06	Default	N/A
Slot 2	Pr 16.06	Range	-3 to 9999
Slot 3	Pr 17.06	Access	RO

The SM-INTERBUS network activity can be monitored in the operating status parameter, Pr **MM.06**. When the SM-INTERBUS is communicating successfully with the INTERBUS master controller, the operating status will give an indication of the number of cyclic data messages per second that are being processed.

If Pr **MM.06** is a negative value, this indicates a non-operational state. Refer to 10.5 *SM-INTERBUS operating status* on page 46 for a full list of operating error codes.

5.6 Resetting the SM-INTERBUS

Name	SM-INTERBUS reset		
Slot 1	Pr 15.32	Default	0 (OFF)
Slot 2	Pr 16.32	Range	0 (OFF) to 1 (ON)
Slot 3	Pr 17.32	Access	RW

Changes to the SM-INTERBUS configuration in menu 15, 16 and 17 parameters will not take effect until the SM-INTERBUS has been reset.

To reset an SM-INTERBUS in slot 3:

1. Set Pr **17.32** to ON.
2. When the reset sequence has been completed, Pr **17.32** will be reset to OFF.
3. The SM-INTERBUS will re-initialise using the updated configuration.

NOTE This sequence does NOT store the SM-INTERBUS configuration parameters in the Unidrive SP or the SM-INTERBUS FLASH memory.

5.7 Reset all Solutions Modules

To reset all Solutions Modules fitted on a Unidrive SP:

1. Set Pr **MM.00** to 1070.
2. Press the red RESET button on the Unidrive SP.

NOTE This sequence does NOT store the SM-INTERBUS configuration parameters in the Unidrive SP or the SM-INTERBUS FLASH memory.

6 Cyclic Data

“OUT cyclic data” and “IN cyclic data” describe the direction of cyclic data transfer as seen by the INTERBUS master controller.

6.1 What is cyclic data?

Cyclic data is a method of data transfer that must be set-up during network configuration, but is transmitted automatically once configuration is complete. The high-speed data transfer is achieved by transmitting only data bytes over the INTERBUS network, and relying on local mapping information within the SM-INTERBUS and INTERBUS master controller to ensure that the correct data is sent to the correct locations. This method relies on the master controller program writing and reading data values to and from the registers allocated to the node during network configuration, and the source and destination of IN and OUT data being set-up correctly in the Unidrive SP. The flexibility of the SM-INTERBUS means that each cyclic data OUT channel can be directed to any read-write Unidrive SP parameter. Similarly, each cyclic data IN channel can use any Unidrive SP parameter as a source of data.

NOTE The cyclic data mapping cannot be changed dynamically, as changes to the mapping parameters will only take effect during initialisation of the SM-INTERBUS, i.e. after a reset, or at power up.

6.2 SM-INTERBUS data formats

Name	SM-INTERBUS data format		
Slot 1	Pr 15.05	Default	4
Slot 2	Pr 16.05	Range	0 to 309
Slot 3	Pr 17.05	Access	RW

The SM-INTERBUS can be configured with up to 10 cyclic IN and OUT data words. IN and OUT cyclic data words are mapped using 10 mapping parameters each, with “block mapping” mode (see section 11.4 *Block mapping* on page 55) available for the additional data words. CT Single Word or PPO 4 Word modes of non-cyclic data using cyclic data can also be enabled.

The SM-INTERBUS Data Format is specified as “NNPP”, where NN is the non-cyclic data mode, and PP is the number of cyclic data words.

Table 6.1 Valid SM-INTERBUS data formats

Pr MM.05	NN	PP	Non-cyclic mode	Cyclic words
1 to 10	0	1 to 10	None	1 to 10
100 to 109	1	0 to 9	CT Single Word	0 to 9
200 to 206	2	0 to 6	PPO 4 Word	0 to 6
300 to 309	3	0 to 9	PCP V2.0	0 to 9

The method used to map data to and from the INTERBUS network is similar to the method used in Unidrive SP for mapping analog and digital inputs and outputs. The reference for the source or target parameter is entered in the mapping parameter in the form MMPP, where MM = menu number of the target/source parameter and PP = parameter number of the target/source parameter.

Table 6.2 SM-INTERBUS mapping parameters

IN channel	Mapping parameter			OUT channel	Mapping parameter		
	Slot 1	Slot 2	Slot 3		Slot 1	Slot 2	Slot 3
0	Pr 15.10	Pr 16.10	Pr 17.10	0	Pr 15.20	Pr 16.20	Pr 17.20
1	Pr 15.11	Pr 16.11	Pr 17.11	1	Pr 15.21	Pr 16.21	Pr 17.21
2	Pr 15.12	Pr 16.12	Pr 17.12	2	Pr 15.22	Pr 16.22	Pr 17.22
3	Pr 15.13	Pr 16.13	Pr 17.13	3	Pr 15.23	Pr 16.23	Pr 17.23
4	Pr 15.14	Pr 16.14	Pr 17.14	4	Pr 15.24	Pr 16.24	Pr 17.24
5	Pr 15.15	Pr 16.15	Pr 17.15	5	Pr 15.25	Pr 16.25	Pr 17.25
6	Pr 15.16	Pr 16.16	Pr 17.16	6	Pr 15.26	Pr 16.26	Pr 17.26
7	Pr 15.17	Pr 16.17	Pr 17.17	7	Pr 15.27	Pr 16.27	Pr 17.27
8	Pr 15.18	Pr 16.18	Pr 17.18	8	Pr 15.28	Pr 16.28	Pr 17.28
9	Pr 15.19	Pr 16.19	Pr 17.19	9	Pr 15.29	Pr 16.29	Pr 17.29

“Block mapping” can be used to map several words to consecutive Unidrive SP parameters. Full details about “block mapping” can be found in section 11.4 *Block mapping* on page 55

NOTE If a mapping parameter is set to an invalid value, e.g. destination parameter is read only, or parameter does not exist, the SM-INTERBUS will indicate a mapping error in the operating status parameter, Pr **MM.06**. The reason for the mapping error will be indicated by the mapping status parameter, Pr **MM.49**. Refer to section 10.7 *SM-INTERBUS mapping status* on page 48 for more details.

When the data format is configured using Pr **MM.05**, the SM-INTERBUS will communicate using the same number of data words for IN and OUT data. It is not possible to configure the SM-INTERBUS to communicate with different numbers of IN and OUT cyclic data words.

NOTE The cyclic data channels do not use decimal points. For example, in Open Loop mode, the Unidrive SP digital speed reference 1 (Pr **1.21**) has units of Hertz, accurate to 1 decimal place. To write a value of 24.6Hz to Pr **1.21**, the value must be transmitted as 246.

The following sections show some example data formats that can be selected, and the parameter mapping that will apply (by default) to each format.

6.2.1 2 cyclic channels only (default)

This data format provides two cyclic data channels with no non-cyclic data. The total data length is 4 words. To select this data format, set Pr **MM.05** = 4. This data format is selected by default.

Table 6.3 Mapping for 5 cyclic data words

Data word	Slot 1	Slot 2	Slot 3	Default mapping status
IN Word 0, 1	Pr 15.10	Pr 16.10	Pr 17.10	Pr 10.40 , status word
IN Words 2, 3	Pr 15.11	Pr 16.11	Pr 17.11	Pr 2.01 , post-ramp speed reference
OUT Word 0, 1	Pr 15.20	Pr 16.20	Pr 17.20	Pr 6.42 , control word
OUT Word 2, 3	Pr 15.21	Pr 16.21	Pr 17.21	Pr 1.21 , digital speed reference 1

6.2.2 3 cyclic channels with CT Single Word non-cyclic data

This data format provides three cyclic data channels, plus an additional channel for CT Single Word (Mode 1) non-cyclic data. (See section 8 *Non-Cyclic Data* on page 23) The total data length is 8 words. To select this data format, set Pr **MM.05** = 106.

Table 6.4 Mapping for 3 cyclic channels with CT Single Word non-cyclic data

Data word	Slot 1	Slot 1	Slot 1	Default mapping status
IN Word 0, 1	Pr 15.10	Pr 16.10	Pr 17.10	Pr 60.50 , CT Single Word
IN Word 2, 3	Pr 15.11	Pr 16.11	Pr 17.11	Pr 10.40 , status word
IN Word 4, 5	Pr 15.12	Pr 16.12	Pr 17.12	Pr 2.01 , post-ramp speed reference
IN Word 6, 7	Pr 15.13	Pr 16.13	Pr 17.13	0, not mapped
OUT Word 0, 1	Pr 15.20	Pr 16.20	Pr 17.20	Pr 60.50 , CT Single Word
OUT Word 2, 3	Pr 15.21	Pr 16.21	Pr 17.21	Pr 6.42 , control word
OUT Word 4, 5	Pr 15.22	Pr 16.22	Pr 17.22	Pr 1.21 , digital speed reference 1
OUT Word 6, 7	Pr 15.23	Pr 16.23	Pr 17.23	0, not mapped

6.2.3 5 cyclic channels only

This data format provides five cyclic data channels, with no non-cyclic data channel. The total data length is 10 words. To select this data format, set Pr **MM.05** = 10.

Table 6.5 Mapping for 5 cyclic channels

Data word	Slot 1	Slot 2	Slot 3	Default mapping status
IN Word 0, 1	Pr 15.10	Pr 16.10	Pr 17.10	Pr 10.40 , status word
IN Word 2, 3	Pr 15.11	Pr 16.11	Pr 17.11	Pr 2.01 , post-ramp speed reference
IN Word 4-9	Pr 15.12 to Pr 15.14	Pr 16.12 to Pr 16.14	Pr 17.12 to Pr 17.14	0, not mapped
OUT Word 0, 1	Pr 15.20	Pr 16.20	Pr 17.20	Pr 6.42 , control word
OUT Word 2, 3	Pr 15.21	Pr 16.21	Pr 17.21	Pr 1.21 , digital speed reference 1
OUT Word 4-9	Pr 15.22 to Pr 15.24	Pr 16.22 to Pr 16.24	Pr 17.22 to Pr 17.24	0, not mapped

Block mapping can be used to map the remaining un-used data words to Unidrive SP or SM-Applications parameters. See section 11.4 *Block mapping* on page 55.

6.2.4 3 cyclic channels with PPO 4 Word non-cyclic data

This data format provides three cyclic data channels, plus an additional 4 words for PPO 4 Word (Mode 2) non-cyclic data. (See section 8 *Non-Cyclic Data* on page 23) The total data length is 10 words. To select this data format, set Pr **MM.05** = 206.

Table 6.6 Mapping for 3 cyclic channels with PPO 4 Word non-cyclic data

Data word	Slot 1	Slot 1	Slot 1	Default mapping status
IN Word 0-3	Pr 15.10	Pr 16.10	Pr 17.10	Pr 60.51 , Mode 2 non-cyclic data
IN Word 4, 5	Pr 15.11	Pr 16.11	Pr 17.11	Pr 10.40 , status word
IN Word 6, 7	Pr 15.12	Pr 16.12	Pr 17.12	Pr 2.01 , post-ramp speed reference
IN Word 8, 9	Pr 15.13	Pr 16.13	Pr 17.13	0, not mapped
OUT Word 0-3	Pr 15.20	Pr 16.20	Pr 17.20	Pr 60.51 , Mode 2 non-cyclic data
OUT Word 4, 5	Pr 15.21	Pr 16.21	Pr 17.21	Pr 6.42 , control word
OUT Word 6, 7	Pr 15.22	Pr 16.22	Pr 17.22	Pr 1.21 , digital speed reference 1
OUT Word 8, 9	Pr 15.23	Pr 16.23	Pr 17.23	0, not mapped

6.2.5 3 cyclic channels with PCP non-cyclic data

This data format provides three cyclic data channels with PCP (Mode 3) non-cyclic data. (See section 8.3 *Mode 3 - Peripheral Communications Protocol (V2.0)* on page 40) The total data length is 7 words. To select this data format, set Pr **MM.05** = 306.

Table 6.7 Mapping for 3 cyclic channels with PCP non-cyclic data

Data word	Slot 1	Slot 1	Slot 1	Default mapping status
IN Word 0, 1	Pr 15.10	Pr 16.10	Pr 17.10	Pr 10.40 , status word
IN Word 4, 5	Pr 15.11	Pr 16.11	Pr 17.11	Pr 2.01 , post-ramp speed reference
IN Word 8, 9	Pr 15.12	Pr 16.12	Pr 17.12	0, not mapped
OUT Word 0, 1	Pr 15.20	Pr 16.20	Pr 17.20	Pr 6.42 , control word
OUT Word 2, 3	Pr 15.21	Pr 16.21	Pr 17.21	Pr 1.21 , digital speed reference 1
OUT Word 4, 5	Pr 15.22	Pr 16.22	Pr 17.22	0, not mapped

There is no mapping required when the peripheral communications protocol is enabled. The PCP channel will use 1 cyclic data word, but it cannot be accessed directly in the PLC or the SM-INTERBUS.

6.3 Cyclic data mapping errors

The SM-INTERBUS will scan and check the mapping parameter configuration for errors during initialisation, i.e. after reset. If an error is detected, the SM-INTERBUS operating status parameter (Pr **MM.06**) will indicate -3, and the mapping error detected will be indicated in SM-INTERBUS mapping status parameter, Pr **MM.49**. See section 10.7 *SM-INTERBUS mapping status* on page 48 for full details.

6.4 Storing SM-INTERBUS configuration parameters

Name	Store to SM-INTERBUS FLASH memory		
Slot 1	Pr 15.31	Default	OFF
Slot 2	Pr 16.31	Range	OFF (0) to ON (1)
Slot 3	Pr 17.31	Access	RW

Menu 15, 16 and 17 parameters are stored in the Unidrive SP. The SM-INTERBUS will always use these values during initialisation to configure itself, so if a new SM-INTERBUS is fitted to the same slot, it will communicate using the same settings as the previous SM-INTERBUS.

NOTE If the stored values in the Unidrive SP are for a different type of Solutions Module, the Unidrive SP will trip on “SLx.dF”. The slot configuration parameters will be set to default values for SM-INTERBUS, but the default values will NOT be stored in the Unidrive SP.

The SM-INTERBUS configuration parameters can also be stored in the FLASH memory on the SM-INTERBUS. If the Unidrive SP is replaced, the SM-INTERBUS configuration parameters can subsequently be restored to the Unidrive SP.

6.4.1 Saving Unidrive SP parameters

To store Unidrive SP parameters:

1. Set Pr **MM.00** to 1000.
2. Press the red RESET button.

The Unidrive SP will store all parameters (except Menu 20) but the operation of the SM-INTERBUS will not be affected. Changes made to the SM-INTERBUS configuration parameters will not take effect until the SM-INTERBUS is reset.

NOTE Unidrive SP parameters are NOT stored in the SM-INTERBUS.

6.4.2 Storing parameters to SM-INTERBUS FLASH memory

To store the SM-INTERBUS configuration parameters in the FLASH memory in the SM-INTERBUS in slot 3:

1. Set Pr **17.31** to ON.
2. Set Pr **MM.00** to 1000.
3. Press the red RESET button.

The Unidrive SP will store its parameters, and INTERBUS communication will be halted immediately. The SM-INTERBUS configuration parameters will be saved within the SM-INTERBUS FLASH memory. The SM-INTERBUS will then reset and re-initialise using the updated configuration parameter values.

6.5 Disabling cyclic data channels

If any data words are not being used in an application, the unused mapping parameters should be set to 0. Although the data word will still be transmitted over the INTERBUS network, any incoming data value will be discarded. Unmapped data words being passed back to the INTERBUS master controller will be set to 0.

7 Control and Status Words

7.1 Unidrive SP control word

The Unidrive SP control word allows the digital control of the Unidrive SP to be implemented using a single data word. Each bit in the control word has a particular function, and Provides a method of controlling the output functions of the Unidrive SP (RUN FWD, JOG, TRIP, etc.) with a single data word.

NOTE The Unidrive SP control word (Pr 6.42) must be enabled by setting control word enable (Pr 6.43) to 1. When the control word is enabled, the source of the control signals (ENABLE, RUN FWD, JOG, etc.) is selected using the AUTO bit.

b15	b14	b13	b12b	b11	b10	b9	b8
	KEYPAD WDOG	RESET	TRIP			JOG REV	REMOTE
b7	b6	b5	b4	b3	b2	b1	b0
AUTO	NOT STOP	RUN	FWD REV	RUN REV	JOG	RUN FWD	ENABLE

NOTE For safety reasons, the external HARDWARE ENABLE signal (terminal 31) must be present (connected to +24V, terminal 22) before the fieldbus control word can be used to start the Unidrive SP. Typically, this terminal is controlled by the external Emergency Stop circuit to ensure that the Unidrive SP is disabled in an emergency situation.

To select external fieldbus control, set the AUTO bit to 1. This selects the control word (Pr 6.42) as the source for the control functions of the Unidrive SP. When AUTO is reset to 0, the Unidrive SP will revert to terminal control.

To select the INTERBUS speed reference, set the REMOTE bit to 1. As the REMOTE bit directly controls Pr 1.42, this will select the digital speed reference as the main speed reference for the Unidrive SP. When REMOTE is reset to 0, the Unidrive SP will revert to using the external analog speed reference.

NOTE By default, the digital speed reference will be Pr 1.21, which is also the default mapping for the fieldbus speed reference. The actual digital speed reference selected when REMOTE is set to 1 will depend on the setting of the digital speed reference selector, Pr 1.15.

Table 7.1 Unidrive SP control word bit functions

Bit	Function	Description
0	ENABLE	Set to 1 to enable the Unidrive SP. Resetting to 0 will immediately disable the Unidrive SP, and the motor will coast to stop. The external HARDWARE ENABLE signal must also be present before the Unidrive SP can run.
1	RUN FWD	Set to 1 (with ENABLE set to 1) to run the motor in the forward direction. When reset to 0, the Unidrive SP will decelerate the motor to a controlled stop before the PWM output stack is disabled
2	JOG	Set to 1 to jog the motor. JOG must be set BEFORE setting RUN FWD or RUN REV to enable the Unidrive SP. The direction is specified by RUN FWD and RUN REV. (The motor can also be jogged by using the RUN and FWD REV bits instead of RUN FWD and RUN REV.)

Table 7.1 Unidrive SP control word bit functions

Bit	Function	Description
3	RUN REV	Set to 1 (with ENABLE set to 1) to run the motor in the reverse direction. When reset to 0, the Unidrive SP will decelerate the motor to a controlled stop before the PWM output stack is disabled
4	FWD REV	Set to 1 to select the reverse direction when operating with a RUN and DIRECTION signal. Set to 0 to run in the forward direction. The RUN signal is used to start and stop the motor.
5	RUN	Set to 1 to run the motor when operating with a RUN and DIRECTION signal. FWD REV is used to select the direction of motor rotation. When reset to 0, the Unidrive SP will decelerate the motor to a controlled stop before the PWM output stack is disabled.
6	NOT STOP	Set to 1 to allow the sequencing bit to be latched. If NOT STOP is zero, all latches are cleared and held at 0.
7	AUTO	Set to 1 to enable the Unidrive SP Control Word. The Control Word Enable (Pr 6.43) must also be set to 1. When reset to 0, the Unidrive SP will operate under terminal control.
8	REMOTE	Set to 1 to select digital speed reference 1 (Pr 1.21), and reset to 0 to select analog reference 1 (Pr 1.36). REMOTE directly controls Pr 1.42, so reference selector (Pr 1.14) and preset selector (Pr 1.15) must both be set to 0 (default) for the REMOTE bit to work properly.
9	JOG REV	Set to 1 to jog the motor in the reverse direction. JOG must be set BEFORE setting RUN to enable the Unidrive SP. (Unidrive SP V1.01.00 and later only.)
10-11	Reserved	
12	TRIP	Set to 1 to trip the Unidrive SP at any time. The trip display on Unidrive SP will be "CL.bit" and the trip code will be 35. AUTO (b7) has no effect on this function. The trip cannot be cleared until TRIP is reset to 0.
13	RESET	A 0-1 transition of the RESET bit will reset the Unidrive SP from a trip condition. If the reason for the trip is still present, for another fault condition has been detected, the Unidrive SP will immediately trip again. When resetting the Unidrive SP, it is recommended to check the status word to ensure that the reset was successful, before attempting to re-start the Unidrive SP.
14	KEYPAD WDOG	Reserved for use with external keypads.
15	Reserved	

NOTE When a trip occurs, the Unidrive SP control word **MUST** be set to a safe, disabled state. This ensures that the Unidrive SP does not re-start unexpectedly when it is reset. This can be achieved by continuously monitoring the Unidrive SP status word, and interlocking it with the control word.

The diagram below shows the key for the Unidrive SP control word sequencing logic diagram.

Figure 7-1 Control sequencer logic diagram key

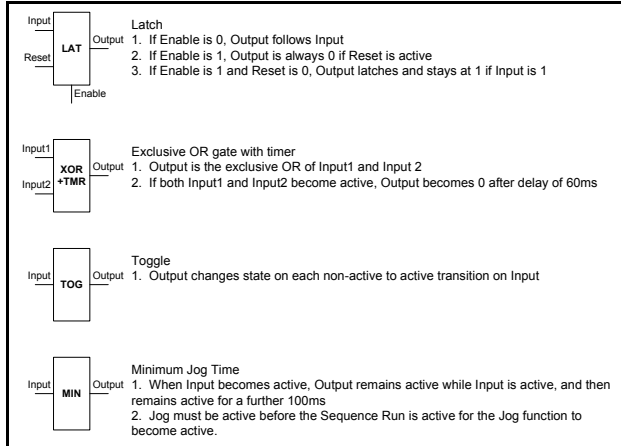
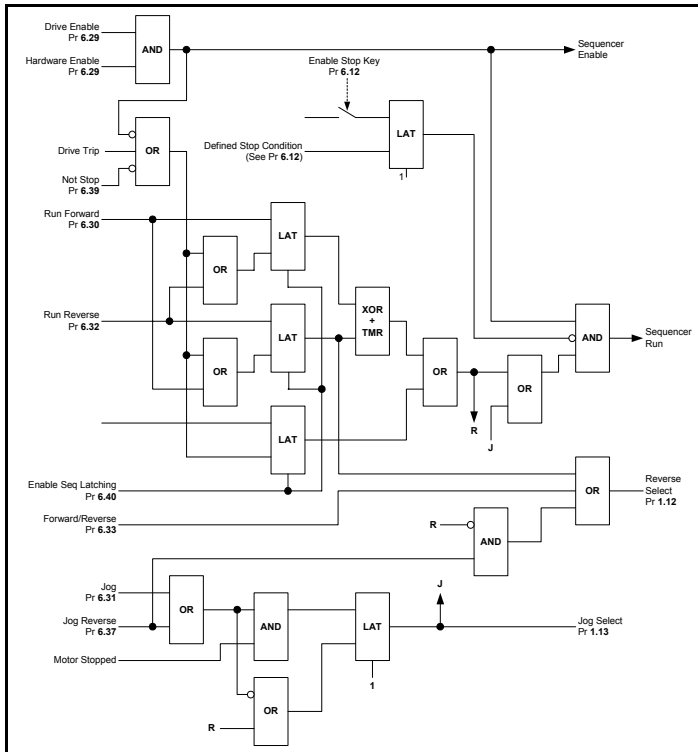

Figure 7-2 Control sequencer logic diagram



Some example Unidrive SP control word values are given in the table below.

Table 7.2 Example Unidrive SP control words

Control word (Hex)	Control word (Dec.)	Action
0x0000	0	Control word disabled, Unidrive SP will operate under terminal control
0x0080	128	Disabled
0x0081	129	Enabled, stopped
0x0183	387	Enabled, run fwd, digital speed ref
0x0189	393	Enabled, run rev, digital speed ref
0x0083	131	Enabled, run fwd, analog speed ref
0x0089	137	Enabled, run rev, analog speed ref
0x01A1	417	Enabled, run fwd, digital speed ref
0x01B1	433	Enabled, run rev, digital speed ref
0x00A1	161	Enabled, run fwd, analog speed ref
0x00B1	177	Enabled, run rev, analog speed ref
0x0085 > 0x0087	133 > 135	Enabled, jog > Enabled, jog fwd
0x0085 > 0x008D	133 > 141	Enabled, jog > Enabled, jog rev
0x1000	4096	Trip Unidrive SP
0x2080	8320	Reset Unidrive SP into fieldbus control, disabled
0x2000	8192	Reset Unidrive SP into terminal control

7.2 Unidrive SP status word

The status word returns the status of multiple functions within the Unidrive SP, e.g. At speed, Zero speed, Drive healthy, etc., and provides a quick method of checking the current status of the Unidrive SP. The status word is mapped to cyclic data as Pr 10.40.

b15	b14	b13	b12b	b11	b10	b9	b8
Not Used	Pr 10.15	Pr 10.14	Pr 10.13	Pr 10.12	Pr 10.11	Pr 10.10	Pr 10.09

b7	b6	b5	b4	b3	b2	b1	b0
Pr 10.08	Pr 10.07	Pr 10.06	Pr 10.05	Pr 10.04	Pr 10.03	Pr 10.02	Pr 10.01

The table below shows the function indicated by each bit in the status word when set to 1. A bit set to 0 indicates that the condition is false.

Table 7.3 Unidrive SP status word bit functions

Bit	Parameter	Description
0	Pr 10.01	Drive healthy Indicates the Unidrive SP is not in the trip state. If the auto-reset feature is being used, this bit is not reset until all auto-resets have been attempted and the next trip occurs.
1	Pr 10.02	Drive active Indicates that the output stage of the Unidrive SP is active.

Table 7.3 Unidrive SP status word bit functions

Bit	Parameter	Description
2	Pr 10.03	Zero speed In Open Loop mode, zero speed indicates that the absolute value of the post-ramp speed reference (Pr 2.01) is at or below the zero speed threshold defined by Pr 3.05. In Closed Loop and Servo modes, zero speed indicates that the absolute value of speed feedback (Pr 3.02) is at or below the zero speed threshold defined by Pr 3.05.
3	Pr 10.04	Running at or below minimum speed In bipolar mode (Pr 1.10 = 1) Pr 10.04 is the same as zero speed, Pr 10.03. (See above.) In unipolar mode, Pr 10.04 is set if the absolute value of the post-ramp speed reference (Pr 2.01) or speed feedback (Pr 3.02) is at or below minimum speed + 0.5Hz or 5rpm. (Minimum speed is defined by Pr 1.07.) This parameter is only set if the Unidrive SP is running.
4	Pr 10.05	Below set speed Only set if the Unidrive SP is running. Refer to Pr 3.06, Pr 3.07 and Pr 3.09 in the <i>Unidrive SP Advanced User Guide</i> .
5	Pr 10.06	At speed Only set if the Unidrive SP is running. Refer to Pr 3.06, Pr 3.07 and Pr 3.09 in the <i>Unidrive SP Advanced User Guide</i> .
6	Pr 10.07	Above set speed Only set if the Unidrive SP is running. Refer to Pr 3.06, Pr 3.07 and Pr 3.09 in the <i>Unidrive SP Advanced User Guide</i> .
7	Pr 10.08	Load reached Indicates that the modulus of the active current is greater or equal to the rated active current, as defined in menu 4. Refer to the <i>Unidrive SP Advanced User Guide</i> for more details.
8	Pr 10.09	In current limit Indicates that the current limits are active.
9	Pr 10.10	Regenerating In Open Loop, Closed Loop and Servo modes, regenerating indicates that power is being transferred from the motor to the Unidrive SP. In Regen mode, regenerating indicates that power is being transferred from the supply to the Unidrive SP.
10	Pr 10.11	Dynamic brake active Indicates that the braking IGBT is active. If the IGBT becomes active, this parameter will remain on for at least one second.
11	Pr 10.12	Dynamic brake alarm Dynamic brake alarm is set when the braking IGBT is active, and the braking energy accumulator is greater than 75%.
12	Pr 10.13	Direction commanded Direction commanded is set to 1 if the Pr e-ramp speed reference (Pr 1.03) is negative, and reset to 0 if the Pr e-ramp speed reference is zero or positive.
13	Pr 10.14	Direction running In Open Loop mode, direction running is set to 1 if the post-ramp speed reference (Pr 2.01) is negative, and reset to 0 if the post-ramp speed reference is zero or positive. In Closed Loop Vector and Servo modes, direction running is set to 1 if the Speed Feedback (Pr 3.02) is negative, and reset to 0 if the speed feedback is zero or positive.

Table 7.3 Unidrive SP status word bit functions

Bit	Parameter	Description
14	Pr 10.15	Mains loss In Open Loop, Closed Loop Vector and Servo modes, mains loss indicates that the drive has detected mains loss from the level of the DC bus voltage. This parameter can only become active if mains loss ride through or mains loss stop modes are selected. Refer to Pr 6.03 in the <i>Unidrive SP Advanced User Guide</i> the for more details. In Regen mode, mains loss is the inverse of Pr 3.07. Refer to the <i>Unidrive SP Advanced User Guide</i> the for more details.
15	Not Used	Reserved

7.3 Legacy Control Words

SM-INTERBUS can emulate the Unidrive and Commander SE control words if required, allowing Unidrive or Commander SE to be replaced in an existing system without the need to re-program the control logic in the main controller program. The INTERBUS master will need to re-configured to allow communications with the SM-INTERBUS.

8 Non-Cyclic Data

The non-cyclic data channel provides a method for the master controller to read from or write to any parameter within the Unidrive SP. This channel can be used for single infrequent data transfers, or uploading and downloading parameter sets to or from a particular node.

The SM-INTERBUS provides three non-cyclic data formats, plus the option to disable non-cyclic data.

1. CT Single Word format. (Mode 1, see section 8.1 *Mode 1 - CT Single Word mode* .)
2. PPO 4 Word format. (Mode 2, see section 8.2 *Mode 2 - PPO 4 Word mode* on page 33.)
3. Peripheral Communications Protocol V2.0. (Mode 3, see section 8.3 *Mode 3 - Peripheral Communications Protocol (V2.0)* on page 40.)

Table 8.1 SM-INTERBUS non-cyclic modes

Non-cyclic mode	Data format (Pr MM.05)	Description
Disabled	0.xx	Non-cyclic data disabled.
CT Single Word	1.xx	CT Single Word Format. Uses 2 cyclic data words if data compression is disabled, or 1 cyclic word if data compression is enabled.
PPO 4 Word	2.xx	PPO 4 Word Format. Uses 4 cyclic data words.
PCP V2.0	3.xx	Peripheral Communications protocol (PCP) V2.0. Uses 1 of the available cyclic data words.

NOTE The non-cyclic data channel does not use decimal points. For example, the digital speed reference 1 (Pr 1.21) has units of Hertz, accurate to 1 decimal place. To write a value of 24.6Hz to Pr 1.21, the value must be transmitted as 246.

8.1 Mode 1 - CT Single Word mode

The CT Single Word (Mode 1) uses one cyclic channel for non-cyclic data. The non-cyclic sub-protocol for Unidrive SP requires a specific sequence of 4 or 6 telegrams to implement the parameter access. Each non-cyclic word or telegram is split into 2 bytes to implement the sub-protocol, with the high byte containing the control codes for each telegram, and the low byte containing the data for each telegram.

NOTE If cyclic data compression is disabled, the CT Single Word non-cyclic channel will be 32-bits wide, i.e. uses 2 words, and data must be transferred on the low word. If cyclic data compression is enabled, the CT Single Word non-cyclic channel will revert to 16-bits and only use 1 word.

8.1.1 Mapping For CT Single Word non-cyclic data

To configure an SM-INTERBUS in slot 3 for CT Single Word Mode non-cyclic data, the following steps must be performed:

1. Set Pr 17.05 to the required mode.
2. Set Pr 17.32 to ON to reset and reconfigure the SM-INTERBUS.

When the SM-INTERBUS re-initialises, it will map cyclic data IN Word 0 and OUT Word 0 to the CT Single Word protocol parameter, Pr 61.50. All existing mapping parameters will be moved down by 1 word, i.e. the previous mapping set in Pr 17.10 and Pr 17.20

will now appear in Pr 17.11 and Pr 17.21. The table below shows what happens to the mappings when the data format is changed from 4 cyclic words to 4 cyclic words with CT Single Word non-cyclic data.

Table 8.2 CT Single Word non-cyclic data mapping

Mapping parameter	Before format change (Pr 17.05 = 5)		After format change (Pr 17.05 = 105)	
	Value	Mapping	Value	Mapping
Pr 17.10	1040	Pr 10.40, status word	6150	Pr 61.50, CT Single Word
Pr 17.11	201	Pr 2.01, post ramp speed ref	1040	Pr 10.40, status word
Pr 17.12	0	Not mapped	201	Pr 2.01, post ramp speed ref
Pr 17.13 to Pr 17.19	0	Not mapped	0	Not mapped
Pr 17.20	642	Pr 6.42, control word	6150	Pr 61.50, CT Single Word
Pr 17.21	121	Pr 1.21, digital speed ref 1	642	Pr 6.42, control word
Pr 17.22	0	Not mapped	121	Pr 1.21, digital speed ref 1
Pr 17.23 to Pr 17.29	0	Not mapped	0	Not mapped

NOTE If all IN or OUT mapping parameters are being used when the data format change is implemented, the last mapping parameter value will be lost.

8.1.2 CT Single Word protocol

All parameter values for Unidrive SP must be written as signed 32-bit data values. Decimal point information is inserted automatically when the data value is written to the Unidrive SP, and removed when the data value is read. Hence, the number of decimal places of the target parameter must be known. Writing a value of 1234 to a parameter with 2 decimal places will produce a value of 12.34 in the target parameter. Similarly, reading a value of 12.34 will return a 32-bit integer value of 1234.

b15	b14	b13	b12	b11	b10	b9	b8
READ	ERR	Reserved	32-BIT	Stamp Number			

b7	b6	b5	b4	b3	b2	b1	b0
Data Byte							

Table 8.3 CT Single Word format

Bit	Function	Values	Description
0 to 7	Data	0 to 255	Depending on the stamp number of the telegram, this byte contains the menu, parameter or data byte
8 to 11	Stamp number	0 to 6	Indicates the stamp number of the word. This shows which part of the message is currently in progress. Setting the stamp number to 0 resets the internal non-cyclic state machine
12	32-BIT	0 = 16-bit data 1 = 32-bit data	Specifies whether a 16-bit or 32-bit data value is to be written to or read from the Unidrive SP. If 32-BIT is set, telegrams 5 and 6 will be used to transfer the additional data bytes

Table 8.3 CT Single Word format

Bit	Function	Values	Description
13	Reserved	0	Reserved for future use. Always set to 0
14	ERR	0 = Data OK 1 = Error	Indicates the success or failure of the message. Failure could occur if the parameter does not exist, or is a read-only or write-only parameter. This bit will also be set if the parameter value is out of range in 16-bit mode.
15	READ	0 = Write 1 = Read	Defines whether the data word is part of a READ or WRITE cycle.

8.1.3 16-bit parameter access

16-bit data can be used to access parameters within the Unidrive SP using only 4 telegrams. If an attempt is made to read a 32-bit parameter from the Unidrive SP, the parameter value will be returned, provided that the parameter value does not exceed a signed 16-bit limits. If the value is larger than a signed 16-bit value, the ERR bit will be set.

When writing data to a 32-bit parameter, the 16-bit data will be treated as a signed 16-bit data value. This limits the range that can be written to a 32-bit parameter.

8.1.4 Reading parameters using CT Single Word

To read 32-bit parameters using the non-cyclic channel, the following “telegrams” must be transmitted to construct the final message.

- Telegram 1 Define menu number.
- Telegram 2 Define parameter number.
- Telegram 3 Request high data byte.
- Telegram 4 Request mid-high data byte.
- Telegram 5 Request mid-low data byte.
- Telegram 6 Request low data byte.

Figure 8-1 CT Single Word read sequence

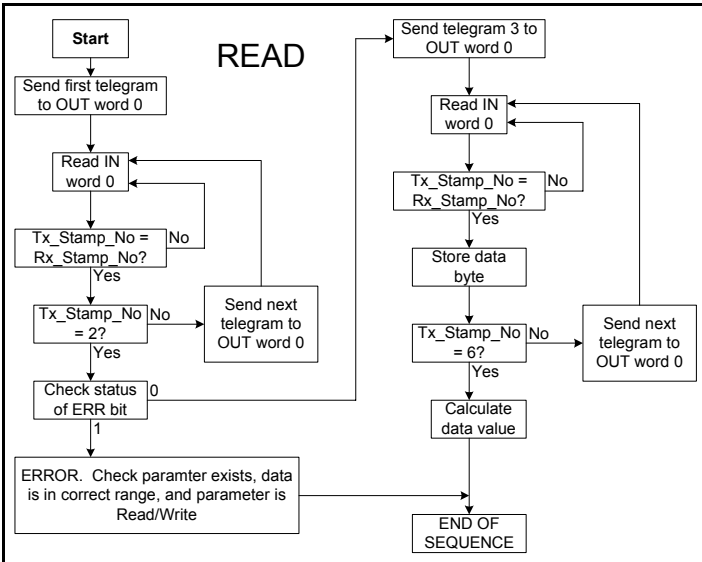

The following example telegrams show how to read the post-ramp speed reference (in rpm with 2 decimal places) from Pr **2.01** in the Unidrive SP.

TELEGRAM 1

The first telegram from the INTERBUS master indicates a READ cycle, and the stamp number is 1. The data byte would contain the menu number for the parameter that is to be read.

Bit	b15-b12	b11-b8	b7-b4	b3-b0
Value	1001	0001	0000	0010

Data word = 0x9102

Stamp number = 1

Menu = 2

When the first telegram has been received and processed in the slave node, it is mirrored in the non-cyclic IN word back to the PLC. This is the signal to the master controller Program that the first telegram of the message has been received and understood, and the second telegram can be transmitted.

TELEGRAM 2

The second telegram from the INTERBUS master also indicates a READ cycle, but the stamp number is now 2. The data byte would contain the parameter number for the parameter that is to be read.

Bit	b15-b12	b11-b8	b7-b4	b3-b0
Value	1001	0010	0000	0001

Data word = 0x9201

Stamp number = 2

Parameter = 1

When the second telegram has been received and processed in the slave, it is mirrored in the non-cyclic IN word. This is the signal to the master controller Program that the second telegram of the message has been received and understood, and the third telegram can be transmitted.

If telegrams 1 and 2 were not received correctly, or an invalid parameter was specified, e.g. parameter is write only, or does not exist, the INTERBUS interface will set the ERROR bit to 1 (b14 = 1). The data bits will have no significance.

Bit	b15-b12	b11-b8	b7-b4	b3-b0
Value	1101	0010	0000	0001

Data word = 0xD201

Stamp number = 2

If an error is reported, it is recommended that the non-cyclic data word is set to 0 to ensure that the non-cyclic state machine is completely reset, and ready for the next non-cyclic READ or WRITE sequence.

TELEGRAM 3

The third telegram from the INTERBUS master acts as the indication to the slave to send the high data byte from the requested parameter. The data byte is not used in this telegram, and should be set to 0.

Bit	b15-b12	b11-b8	b7-b4	b3-b0
Value	1001	0011	0000	0000

Data word = 0x9300

Stamp number = 3

When the third telegram has been received and processed in the slave node, the node will mirror the stamp number in the non-cyclic IN word, and load the high byte of the parameter value into the data byte.

Bit	b15-b12	b11-b8	b7-b4	b3-b0
Value	1001	0011	0000	0000

Data word = 0x9300

Stamp number = 3

Data high byte = 0x00 = 0

TELEGRAM 4

The fourth telegram from the INTERBUS master acts as the indication to the slave to send the mid-high data byte from the requested parameter. The data byte is not used in this telegram, and should be set to 0.

Bit	b15-b12	b11-b8	b7-b4	b3-b0
Value	1001	0100	0000	0000

Data word = 0x9400

Stamp number = 4

When the fourth telegram has been received and processed in the slave node, the node will mirror the stamp number in the non-cyclic IN word, and load the mid high byte of the parameter value into the data byte.

Bit	b15-b12	b11-b8	b7-b4	b3-b0
Value	1001	0100	0000	0001

Data word = 0x9401

Stamp number = 4

Data mid high byte = 0x01 = 1

TELEGRAM 5

The fifth telegram from the INTERBUS master acts as the indication to the slave to send the mid-low data byte from the requested parameter. The data byte is not used in this telegram, and should be set to 0.

Bit	b15-b12	b11-b8	b7-b4	b3-b0
Value	1001	0101	0000	0000

Data word = 0x9500

Stamp number = 5

When the fifth telegram has been received and processed in the slave node, the node will mirror the stamp number in the non-cyclic IN word, and load the mid-low byte of the parameter value into the data byte.

Bit	b15-b12	b11-b8	b7-b4	b3-b0
Value	1001	0101	0010	0101

Data word = 0x9505

Stamp number = 5

Data mid low byte = 0x25 = 37

TELEGRAM 6

The sixth telegram from the INTERBUS master acts as the indication to the slave to send the low data byte from the requested parameter. The data byte is not used in this telegram and should be set to 0.

Bit	b15-b12	b11-b8	b7-b4	b3-b0
Value	1001	0110	0000	0000

Data word = 0x9600

Stamp number = 6

When the sixth telegram has been received and processed in the slave node, the node will mirror the stamp number in the non-cyclic IN word, and load the low byte of the parameter value into the data byte.

Bit	b15-b12	b11-b8	b7-b4	b3-b0
Value	1001	0110	1101	1100

Data word = 0x96DC

Stamp number = 6

Data low byte = 0xDC = 220

$$\begin{aligned}\text{Speed} &= (\text{High byte} * 2^{24}) + (\text{Mid-high byte} * 2^{16}) + (\text{Mid-low byte} * 2^8) + \text{Low byte} \\ &= (0 * 16777216) + (1 * 65536) + (37 * 256) + 220 \\ &= 75228 \\ &= 7522.8 \text{ rpm}\end{aligned}$$

8.1.5 Writing parameters using CT Single Word

To write to a 32-bit parameter using the non-cyclic channel, the following telegrams must be sent on each network cycle to construct the final message.

- Telegram 1 Define menu number.
- Telegram 2 Define parameter number.
- Telegram 3 Send high data byte.
- Telegram 4 Send mid-high data byte.
- Telegram 5 Send mid-low data byte.
- Telegram 6 Send low data byte.

Figure 8-2 CT Single Word write sequence

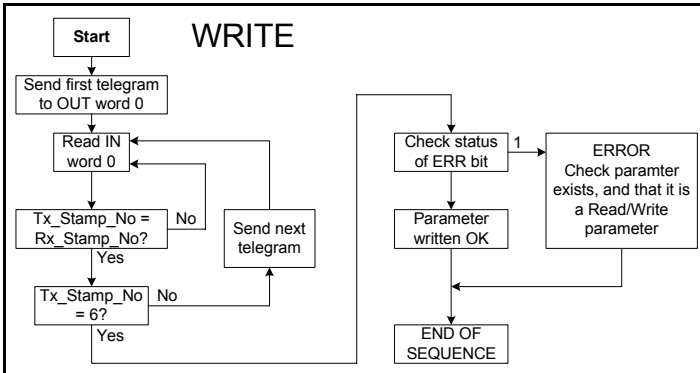

The following example telegrams show how to set the digital speed reference 1 (Pr 1.21) to 12553.9 rpm (32-bit value is 125539) in the Unidrive SP.

TELEGRAM 1

The first telegram from the INTERBUS master indicates a WRITE cycle by setting the R/W bit to 0. The stamp number is set to 1. The data byte contains the menu number for the parameter that is to be written to.

Bit	b15-b12	b11-b8	b7-b4	b3-b0
Value	0001	0001	0000	0001

Data word = 0x1101

Stamp number = 1

Menu = 1

When the first telegram has been received and processed in the slave node, it is mirrored in the non-cyclic IN word. This is the signal to the master controller Program that the first telegram of the message has been received and understood, and the second telegram can be transmitted.

TELEGRAM 2

The second telegram from the INTERBUS master also indicates a Write cycle, but the stamp number is now set to 2. The data byte would contain the parameter number for the parameter that is to be written to.

Bit	b15-b12	b11-b8	b7-b4	b3-b0
Value	0001	0010	0001	0101

Data word = 0x1215

Stamp number = 2

Parameter = 21

When the second telegram has been received and processed in the slave node, it is mirrored in the non-cyclic IN word. This is the signal to the master controller Program that the second telegram of the message has been received and understood, and the third telegram can be transmitted.

TELEGRAM 3

The third telegram from the INTERBUS master has the stamp number set to 3. The data bits contain the high data byte for the parameter being written to.

Bit	b15-b12	b11-b8	b7-b4	b3-b0
Value	0001	0011	0000	0000

Data word = 0x1300

Stamp number = 3

Data high byte = 0x00

When the third telegram has been received and processed in the slave node, it is mirrored in the non-cyclic IN word. This is the signal to the master controller Program that the third telegram of the message has been received and understood, and the fourth telegram can be transmitted.

TELEGRAM 4

The fourth telegram from the INTERBUS master has the stamp number set to 4. The data bits contain the mid-high data byte for the parameter being written to.

Bit	b15-b12	b11-b8	b7-b4	b3-b0
Value	0001	0100	0000	0001

Data word = 0x1401

Stamp number = 4

Data mid-high byte = 0x01 = 1

When the fourth telegram has been received and processed in the slave node, it is mirrored in the non-cyclic IN word. This is the signal to the master controller Program that the third telegram of the message has been received and understood, and the fifth telegram can be transmitted.

TELEGRAM 5

The fifth telegram from the INTERBUS master has the stamp number set to 5. The data bits contain the mid-low data byte for the parameter being written to.

Bit	b15-b12	b11-b8	b7-b4	b3-b0
Value	0001	0101	1110	1010

Data word = 0x15EA

Stamp number = 5

Data mid-low byte = 0xEA = 234

When the fifth telegram has been received and processed in the slave node, it is mirrored in the non-cyclic IN word. This is the signal to the master controller Program that the third telegram of the message has been received and understood, and the sixth telegram can be transmitted.

TELEGRAM 6

The sixth telegram from the INTERBUS master has the stamp number set to 6. The data bits contain the low data byte for the parameter that is being written to.

Bit	b15-b12	b11-b8	b7-b4	b3-b0
Value	0001	0110	0110	0011

Data word = 0x1663

Stamp number = 6

Data low byte = 0x63 = 99

When the sixth telegram has been received and processed in the slave node, it will write the data (Pr 1.21 = 12553.9) as transmitted. (The decimal point is automatically inserted when the data is transferred to the Unidrive SP.) If the operation is successful, the ERR bit is reset to 0 and the telegram is reflected in the non-cyclic IN word.

Bit	b15-b12	b11-b8	b7-b4	b3-b0
Value	0001	0110	0110	0011

Data word = 0x1663

Stamp number = 6

Data low byte = 0x63 = 99

If there was a problem with writing the data to the defined parameter, e.g. parameter is read only, does not exist, or data is out of range, the ERR bit is set to 1.

Bit	b15-b12	b11-b8	b7-b4	b3-b0
Value	0101	0110	0110	0011

Data word = 0x5663

Stamp number = 6

8.1.6 Abort CT Single Word non-cyclic message

The internal state machine that controls the non-cyclic data transfer will only accept a new telegram if it contains the next expected telegram, i.e. after accepting telegram 2, the state machine will only respond to telegram 3. If telegram 4 is received, it will be ignored.

If an error occurs in the master controller that causes the telegrams to get out of step, the master controller Program should time-out, abort the message and reset the non-cyclic state machine.

A Mode 1 non-cyclic message can be abandoned by resetting the state machine. This is done by setting the non-cyclic word to 0.

Bit	b15-b12	b11-b8	b7-b4	b3-b0
Value	0000	0000	0000	0000

Data word = 0x0000

Stamp number = 0

8.2 Mode 2 - PPO 4 Word mode

The PPO 4 Word Format (Mode 2) of non-cyclic data uses 4 cyclic data words for non-cyclic data. This allows any Unidrive SP parameter to be accessed using a single combination of data words.

8.2.1 Mapping for PPO 4 Word non-cyclic data

To configure an SM-INTERBUS in slot 3 for PPO 4 Word Mode non-cyclic data, the following steps must be performed:

1. Set Pr 17.05 to the required mode.
2. Set Pr 17.32 to ON to reset and reconfigure the SM-INTERBUS.

When the SM-INTERBUS re-initialises, it will map IN words 0 to 3 and OUT words 0 to 3 to the PPO 4 Word protocol parameter, Pr 61.51. All existing mapping parameters will be moved down by 1 channel, i.e. the previous mappings set in Pr 17.10 and Pr 17.20 will now appear in Pr 17.11 and Pr 17.21 respectively. The table below shows what happens to the mappings when the data format is changed from 10 cyclic words (Pr MM.05 = 10) to 10 cyclic words with Mode 2 non-cyclic data. (Pr MM.05 = 210)

Table 8.4 PPO 4 Word mode data mapping

Mapping parameter	Before format change (Pr 17.05 = 10)		After format change (Pr 17.05 = 210)	
	Value	Mapping	Value	Mapping
Pr 17.10	1040	Pr 10.40, status word	6151	Pr 61.51, PPO 4 Word
Pr 17.11	201	Pr 2.01, post ramp speed ref	1040	Pr 10.40, status word
Pr 17.12	0	Not mapped	201	Pr 2.01, post ramp speed ref
Pr 17.13 to Pr 17.19	0	Not mapped	0	Not mapped
Pr 17.20	642	Pr 6.42, control word	6151	Pr 61.51, PPO 4 Word
Pr 17.21	121	Pr 1.21, digital speed ref 1	642	Pr 6.42, control word
Pr 17.22	0	Not mapped	121	Pr 1.21, digital speed ref 1
Pr 17.24 to Pr 17.29	0	Not mapped	0	Not mapped

NOTE If all IN or OUT mapping parameters are being used when the data format change is implemented, the last mapping parameter value will be lost.

8.2.2 PPO 4 Word protocol

Decimal point information is inserted automatically when the data value is written to the Unidrive SP, and removed when the data value is read. Hence, the number of decimal places of the target parameter must be known. Writing a value of 1234 to a parameter with 2 decimal places will produce a value of 12.34 in the target parameter. Similarly, reading a value of 12.34 will return a 32-bit integer value of 1234.

The table below shows the data structure required on the OUT data to implement PPO 4 Word request.

Table 8.5 PPO 4 Word OUT data structure

OUT data word	Function			
	b15-b12	b11	b10-b8	b7-b0
OUT word 0	TASK ID	0	MENU	
OUT word 1	PARAMETER		Reserved	
OUT word 2	DATA HIGH word			
OUT word 3	DATA LOW word			

The PPO 4 Word protocol is controlled by the TASK ID and RESPONSE ID. The TASK ID specifies the transaction required, and the remainder of the data words carry the data for the transaction. The table below lists the possible TASK ID codes.

Table 8.6 TASK ID codes

TASK ID	Function	Description
0	No task	No non-cyclic transaction required
1	Fieldbus specific	
2	Fieldbus specific	
3	Fieldbus specific	
4	Not implemented	Reserved
5	Not implemented	Reserved
6	Request parameter value	Read parameter value from Unidrive SP. Specify MENU and PARAMETER, set DATA HIGH word and DATA LOW word to 0.
7	Change parameter value (16 bit)	Write 16-bit parameter value to Unidrive SP. Specify MENU, PARAMETER and DATA LOW word. (Any value in DATA HIGH word will be discarded.) This function can be used to write to 32-bit Unidrive SP parameters, but the range of values is limited to 16-bits.
8	Change parameter value (32 bit)	Write 32-bit parameter value to Unidrive SP. Specify MENU, PARAMETER, DATA HIGH word and DATA LOW word. This function can also be used to write to 16-bit Unidrive SP parameters, but if DATA HIGH word is not set to 0, a value over-range error will be reported.
9	Request last parameter reference	Returns the last parameter for the specified menu. Specify MENU. (Values in PARAMETER, DATA HIGH word and DATA LOW word will be discarded.)

The table below shows the data structure of a PPO 4 Word response that will be returned by a SM-INTERBUS.

Table 8.7 PPO 4 Word IN data structure

IN data word	Function			
	b15-b12	b11	b10-b8	b7-b0
IN word 0	RESPONSE ID	0		MENU
IN word 1	PARAMETER			
IN word 2	DATA HIGH word			
IN word 3	DATA LOW word			

The RESPONSE ID indicates the success or otherwise of the requested transaction. The table below lists the possible RESPONSE ID codes.

Table 8.8 RESPONSE ID codes

RESPONSE ID	Function	Description
0	No task	No non-cyclic transaction active
1	Fieldbus specific	
2	Fieldbus specific	
3	Not implemented	
4	Transfer parameter value (16-bit)	Returns a 16 bit data value from the request parameter value specified by TASK ID 6, or the successful change parameter value (16-bit) specified by TASK ID 7.
5	Transfer parameter value (32-bit)	Returns a 32 bit data value from the request parameter value specified by TASK ID 6, or the successful change parameter value (32-bit) specified by TASK ID 8.
6	Transfer last parameter reference	Returns the highest parameter for the menu specified by request last parameter reference, TASK ID 9.
7	Error - TASK ID could not be executed	The previously specified TASK ID could not be completed. word 3 will return an error code to indicate the reason for the TASK ID failure.
8	Error - read only parameter	Target parameter specified by TASK ID 7 or TASK ID 8 is read only, and cannot be modified.

If RESPONSE ID 7 has been received, the error code can be read from word 3. This will indicate the reason why the TASK ID request failed.

Table 8.9 PPO 4 Word error codes

ERROR CODE	Error	Description
0	Invalid menu	The specified menu does not exist.
1	Parameter is read only	The specified parameter is read only, and cannot be written to.
2	Value out of range	The specified data value is out of range for the parameter.
3	Invalid parameter	The specified parameter does not exist.
18	Parameter error	No last parameter information available.

8.2.3 Reading parameters using PPO 4 Word mode

The diagram below shows the sequence of events required to read a Unidrive SP parameter using the PPO 4 Word non-cyclic channel.

Figure 8-3 PPO 4 Word Read sequence

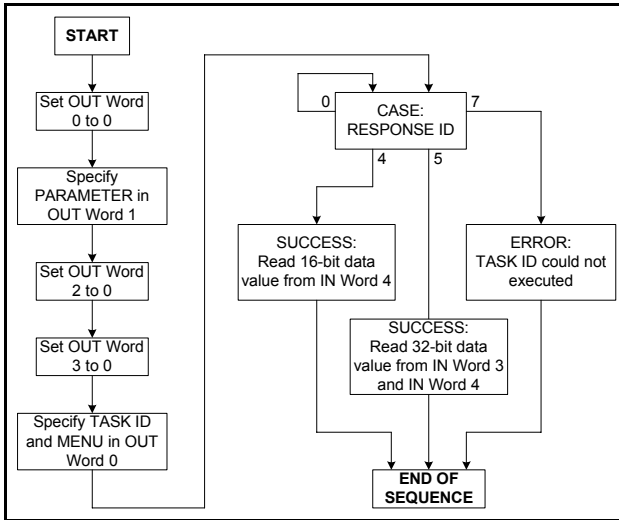

The table below shows the possible TASK ID and RESPONSE ID combinations that may be seen when attempting to read a parameter value from a Unidrive SP.

Table 8.10 PPO 4 Word Read TASK ID and RESPONSE ID combinations

Function	TASK ID	RESPONSE ID	Message status
No Task	0	0	No message active
Request Parameter Value (16 bit)	6	4	Parameter read successfully, 16 bit value returned in word 3
Request Parameter Value (32 bit)	6	5	Parameter read successfully, 32 bit value returned in words 2 and 3
Request Parameter Value (16 bit)	6	7	TASK ID 6 could not be executed. Check the error code in IN word 3 for the reason why.
Request Last Parameter Reference)	9	6	The highest parameter reference in specified menu is available in IN word 3.
Request Last Parameter Reference	9	7	TASK ID 9 could not be executed. Check the error code in IN word 3 for the reason why.

The table below shows an example set of data words for PPO 4 Word mode. This example will read the value in the post ramp speed reference (Pr **2.01**) in the Unidrive SP.

Table 8.11 PPO 4 Word Read Request example

OUT data word	Hex value	Function			
		b15-b12	b11	b10-b8	b7-b0
OUT word 0	0x6002	TASK ID = 6	0	MENU = 2	
OUT word 1	0x0001	PARAMETER = 1		0	
OUT word 2	0x0000	DATA HIGH word = 0			
OUT word 3	0x0000	DATA LOW word = 0			

The table below shows an example successful read response to the read instruction illustrated above. The value returned is 15284, which equates to 1528.4 rpm.

Table 8.12 PPO 4 Word Read Response example

IN data word	Hex value	Function			
		b15-b12	b11	b10-b8	b7-b0
IN word 0	0x5002	RESPONSE ID = 5	0	MENU = 2	
IN word 1	0x0001	PARAMETER = 1		0	
IN word 2	0x0000	DATA HIGH word = 0			
IN word 3	0x3BB4	DATA LOW word = 15284			

NOTE If the OUT data words 0 and 1 are left at the same value, the target parameter will be written to whenever the data value in OUT word 2 or 3 is changed.

8.2.4 Writing parameters using PPO 4 Word mode

The diagram below shows the sequence of events required to write to a Unidrive SP parameter using the PPO 4 Word non-cyclic channel.

Figure 8-4 PPO 4 Word Write sequence

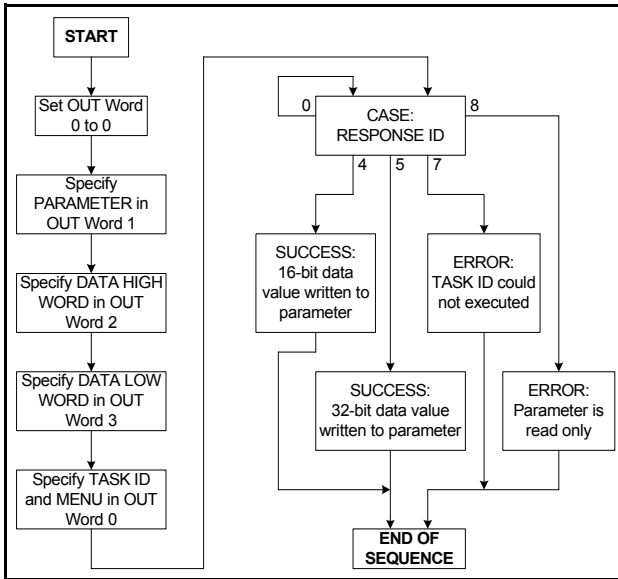

The table below shows the possible TASK ID and RESPONSE ID combinations that may be seen when attempting to write to the Unidrive SP.

Table 8.13 PPO 4 Word Write TASK ID and RESPONSE ID combinations

Function	TASK ID	RESPONSE ID	Message status
No Task	0	0	No message active
Write Parameter Value (16 bit)	7	4	Parameter (16 bit) written successfully
Write Parameter Value (32 bit)	8	5	Parameter (32 bit) written successfully
Write Parameter Value (16 bit)	7	7	TASK ID 7 could not be executed. Check the error code in IN word 3 for the reason why.
Write Parameter Value (32 bit)	8	7	TASK ID 8 could not be executed. Check the error code in IN word 3 for the reason why.
Write Parameter Value (32 bit)	8	8	Parameter is read only, and cannot be written to.

The table below shows an example set of data words for PPO 4 Word mode. This example will write a value of 1553.9 rpm (32-bit value is 15539) to the digital speed reference 1 (Pr 1.21) to in the Unidrive SP.

Table 8.14 PPO 4 Word Write Request example

OUT data word	Hex value	Function			
		b15-b12	b11	b10-b8	b7-b0
OUT word 0	0x8001	TASK ID = 8	0	MENU = 1	
OUT word 1	0x0015	PARAMETER = 21		0	
OUT word 2	0x0001	DATA HIGH word = 0			
OUT word 3	0x3CB3	DATA LOW word = 15539			

The table below shows an example successful write response to the write instruction illustrated above.

Table 8.15 PPO 4 Word Write Response example

IN data word	Hex value	Function			
		b15-b12	b11	b10-b8	b7-b0
IN word 0	0x5001	RESPONSE ID = 5	0	MENU = 1	
IN word 1	0x0015	PARAMETER = 21		0	
IN word 2	0x0000	DATA HIGH word = 0			
IN word 3	0x3CB3	DATA LOW word = 15539			

NOTE If the OUT data words 0 and 1 are left at the same value, the target parameter will be read and the data value in OUT words 2 and 3 updated continuously.

8.3 Mode 3 - Peripheral Communications Protocol (V2.0)

The Peripheral Communication Protocol (PCP) Version 2.0 has server functionality only on the SM-INTERBUS. When an INTERBUS network is initialised, each node supporting PCP is assigned a Communication Reference, or CR. Supported services are listed in Table 8.17.

Table 8.16 PCP Object specification

Attribute	Setting	Value
Index	0x5000 + Menu	0x5000 + Menu
Sub Index	Parameter (>0)	Parameter (>0)
Object code	ARRAY_OBJECT	Array Object
Data-Type Index	INT32	Signed 32 bit value
Length	4	Four octets
Number of Elements	200	Up to parameter 200
Password	0	None
Access-Groups	0	None
Access-Rights	ACC_WRITE_ALL and ACC_READ_ALL	Read and Write
Local-Address	0	Not used
Variable-Name	Menu	Menu
Extension	Not Supported	Not Supported

To configure the PCP channel in the INTERBUS CMD Tool, use the following settings:

Message Length Transmit:64 bytes

Message Length Receive:64 bytes

Client services supported are READ, WRITE and GET OV LONG.

Table 8.17 PCP supported services

Function	Description
INITIATE	Opens a PCP connection with the node at the defined CR
ABORT	Closes the PCP connection to the node at the defined CR
READ	Reads a number of data bytes from an Index and Sub-Index reference in the remote device with the defined CR
WRITE	Writes a specified number of data bytes to an Index and Sub-Index reference in the remote device with the defined CR
STATUS	Returns the current state and current operating state of the remote device at the defined CR
IDENTIFY	Returns the "ID plates" of the device at the defined CR. The following is returned: Manufacturer_Name: "Control Techn." Device_Name: "SM-INTERBUS" Revision: "Version 01.00"

All parameter accesses using the PCP channel are treated as 32-bit, irrespective of the range of the target parameter.

8.3.1 READ object

Index: 0x5000 + Menu

Sub-Index: Parameter

The READ object is used to read a value from a parameter within the Unidrive SP. No additional data bytes are required.

If the read is successful, a success response will be returned, with 4 data bytes containing the value of the target parameter.

1. Data high byte
2. Data mid-high byte
3. Data mid-low byte
4. Data low byte

If an error occurs, an error message is returned, with codes to indicate why the message failed. See section 8.3.3 *Service error codes*.

NOTE Pr **MM.00** (Parameter 0) cannot be accessed directly as the Sub-Index cannot be set to 0. Access to Pr **1.00** is provided via virtual parameter Pr **61.01**

8.3.2 WRITE object

Index: 0x5000 + Menu

Sub-Index: Parameter

The WRITE object is used to send a data value to a parameter within the Unidrive SP. Four bytes are written to this object.

1. Data high byte
2. Data mid-high byte
3. Data mid-low byte
4. Data low byte

If the WRITE is successful, a success response will be returned.

If an error occurs, an error message is returned, with codes to indicate why the message failed. See section 8.3.3 *Service error codes*.

NOTE Pr **MM.00** (Parameter 0) cannot be accessed directly as the Sub-Index cannot be set to 0. Access to Pr **1.00** is provided via virtual parameter Pr **61.01**

8.3.3 Service error codes

If an error occurs while accessing a parameter, a Control Techniques defined error code may be returned. These error codes are listed in Table 8.18.

Table 8.18 Control Techniques defined error codes

Error	Error class	Error code	Additional error code
Parameter Does Not Exist	0x08	0x01	0x00
Parameter Is Read Only	0x08	0x02	0x00
Parameter Is Write Only	0x08	0x03	0x00
Value Outside Permitted Range	0x08	0x04	0x00
Decimal Place Error	0x08	0x05	0x00
Sub-Index Zero Access Error	0x06	0x05	0x11

8.4 SM-INTERBUS set-up using non-cyclic data

The SM-INTERBUS can be configured using the PCP channel, CT Single Word or PPO 4 Word non-cyclic data. The configuration parameters for the slot in which the SM-INTERBUS is located can be accessed as Pr 60.PP.

Changes made to the SM-INTERBUS configuration parameters will not take effect until the has been reset. The SM-INTERBUS can be reset by writing a value of 1 to Pr 60.32. A brief interruption in INTERBUS communications may be seen while the reset sequence is in progress.

9 CMD Tool Support Files

9.1 INTERBUS CMD tool

The CMD tool is the software package used to configure and diagnose the Generation 4 INTERBUS master controllers. An external database file is available from Control Techniques that contains full product descriptions and bitmaps for Unidrive SP, allowing easy inclusion of the Unidrive SP in INTERBUS networks.

CT_IBS.ZIP is available from your local Control Techniques Drive Centre. The ZIP file contains a text file (README_CT.TXT) with instructions on how to install the Unidrive SP support files to the appropriate directories, and import them into the CMD Configuration Tool.

NOTE The INTERBUS CMD tool support files are not essential when configuring an INTERBUS network. Each node can be entered manually, or the master controller can scan the network to determine which nodes are connected.

9.2 SM-INTERBUS CMD tool configuration formats

The data formats supported by the SM-INTERBUS are listed in Table 9.1.

Table 9.1 SM-INTERBUS data formats

Format (Pr 15.05)	Non-cyclic data mode	Cyclic words	INTERBUS ID code	Process data channel width	CMD tool reference
0.01	0	1	0x03 (3)	16 bits	USP_001
0.02	0	2	0x03 (3)	32 bits	USP_002
0.03	0	3	0x03 (3)	48 bits	USP_003
0.04	0	4	0x03 (3)	64 bits	USP_004
0.05	0	5	0x03 (3)	80 bits	USP_005
0.06	0	6	0x03 (3)	96 bits	USP_006
0.07	0	7	0x03 (3)	112 bits	USP_007
0.08	0	8	0x03 (3)	128 bits	USP_008
0.09	0	9	0x03 (3)	144 bits	USP_009
0.10	0	10	0x03 (3)	160 bits	USP_010
1.00	1	0	0x03 (3)	16 bits	USP_100
1.01	1	1	0x03 (3)	32 bits	USP_101
1.02	1	2	0x03 (3)	48 bits	USP_102
1.03	1	3	0x03 (3)	64 bits	USP_103
1.04	1	4	0x03 (3)	80 bits	USP_104
1.05	1	5	0x03 (3)	96 bits	USP_105
1.06	1	6	0x03 (3)	112 bits	USP_106
1.07	1	7	0x03 (3)	128 bits	USP_107
1.08	1	8	0x03 (3)	144 bits	USP_108
1.09	1	9	0x03 (3)	160 bits	USP_109
2.00	2	0	0x03 (3)	64 bits	USP_200
2.01	2	1	0x03 (3)	80 bits	USP_201
2.02	2	2	0x03 (3)	96 bits	USP_202
2.03	2	3	0x03 (3)	112 bits	USP_203

Table 9.1 SM-INTERBUS data formats

Format (Pr 15.05)	Non-cyclic data mode	Cyclic words	INTERBUS ID code	Process data channel width	CMD tool reference
2.04	2	4	0x03 (3)	128 bits	USP_204
2.05	2	5	0x03 (3)	144 bits	USP_205
2.06	2	6	0x03 (3)	160 bits	USP_206
3.00	3	0	0xF3 (243)	0 bits	USP_300
3.01	3	1	0xF3 (243)	16 bits	USP_301
3.02	3	2	0xF3 (243)	32 bits	USP_302
3.03	3	3	0xF3 (243)	48 bits	USP_303
3.04	3	4	0xF3 (243)	64 bits	USP_304
3.05	3	5	0xF3 (243)	80 bits	USP_305
3.06	3	6	0xF3 (243)	96 bits	USP_306
3.07	3	7	0xF3 (243)	112 bits	USP_307
3.08	3	8	0xF3 (243)	128 bits	USP_308
3.09	3	9	0xF3 (243)	144 bits	USP_309

10 Diagnostics

The information from the parameters described below should always be noted before contacting Control Techniques for technical support.

10.1 Module ID code

Name	Module ID code		
Slot 1	Pr 15.01	Default	N/A
Slot 2	Pr 16.01	Range	0 to 499
Slot 3	Pr 17.01	Access	RO

The module ID code indicates the type of solutions module that is fitted in the corresponding slot. The table below shows a list of the solutions modules available for Unidrive SP.

Table 10.1 Solution module ID codes

Module code	Module type	Category
0	None fitted	None
101	SM-Resolver	Position feedback
102	SM-Universal Encoder Plus	Position feedback
103	SM-SLM	Position feedback
201	SM-I/O Plus	I/O expansion
301	SM-Applications	Applications module
302	SM-Applications Lite	Applications module
403	SM-PROFIBUS-DP	Fieldbus
404	SM-INTERBUS	Fieldbus
406	SM-CAN	Fieldbus
407	SM-DeviceNet	Fieldbus
408	SM-CANopen	Fieldbus

10.2 SM-INTERBUS firmware version

Name	SM-INTERBUS firmware - major version		
Slot 1	Pr 15.02	Default	N/A
Slot 2	Pr 16.02	Range	00.00 to 99.99
Slot 3	Pr 17.02	Access	RO

Name	SM-INTERBUS firmware - minor version		
Slot 1	Pr 15.51	Default	N/A
Slot 2	Pr 16.51	Range	0 to 99
Slot 3	Pr 17.51	Access	RO

The full version of the SM-INTERBUS firmware can be read for the corresponding slot. Table 10.2 shows how to construct the full firmware version from these values.

Table 10.2 SM-INTERBUS firmware version

Major version	Minor version	Firmware version
1.01	5	V1.01.05

10.3 SM-INTERBUS node address

INTERBUS networks do not require a node address to be specified for each device. The physical wiring of the network determines the Communication Reference (CR) that will be assigned to each device.

10.4 SM-INTERBUS data rate

INTERBUS networks operate at a fixed data rate of 500 Kbit/s, so there is no requirement to configure the data rate for the SM-INTERBUS module.

10.5 SM-INTERBUS operating status

Name	SM-INTERBUS operating status		
Slot 1	Pr 15.06	Default	N/A
Slot 2	Pr 16.06	Range	-3 to 9999
Slot 3	Pr 17.06	Access	RO

The network activity can be monitored in the SM-INTERBUS operating status parameter, Pr **MM.06**. When the SM-INTERBUS is communicating successfully with the INTERBUS master controller, the operating status will give an indication of the number of cyclic data messages per second that are being processed.

If the operating status shows a negative number, this indicates that the SM-INTERBUS is not currently communicating with the INTERBUS master controller. See Table 10.3 for a list of operating status codes.

Table 10.3 SM-INTERBUS operating status codes

Pr MM.06	Parameter	Description
>0	Network healthy	Indicates the number of processed cyclic messages per second.
0	Network healthy, no data transfer	Indicates that the INTERBUS master has established communications with the SM-INTERBUS. If the operating status changes briefly to -1 and returns to 0, the slave configuration does not match the configuration in the master controller.
-1	Initialised	Indicates that the SM-INTERBUS has initialised correctly, and is waiting for the INTERBUS master to initialise communications.
-2	Internal hardware failure	Indicates that part of the SM-INTERBUS initialisation sequence was not successful. If this fault persists after a power cycle, replace the SM-INTERBUS.
-3	Configuration error	Indicates that there is an invalid setting in the SM-INTERBUS configuration parameters.

10.6 SM-INTERBUS status LEDs

The SM-INTERBUS has 5 status LEDs that allow visual diagnostics. The LEDs can be seen through the ventilation holes on top of the plastic case, as shown in Figure 10-1.

Figure 10-1 SM-INTERBUS status LEDs

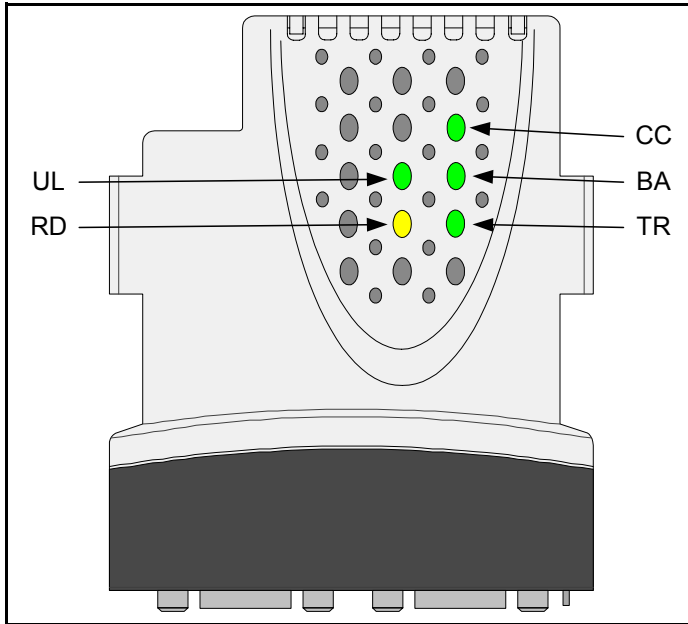

Table 10.4 Status LEDs

Status LED	Colour	Function	Description
CC	Green	Cable Check	Indicates that the cable connection is good, and the SM-INTERBUS is not in the reset state.
BA	Green	Bus Active	Indicates that the bus is active.
TR	Green	Transmit/Receive	Indicates that a Peripheral Communication protocol message is currently in Progress.
RD	Yellow	Remote Bus Disabled	Indicates that the Remote Bus OUT is switched off.
UL	Green	User LED	Indicates that the SM-INTERBUS is powered up.

10.7 SM-INTERBUS mapping status

Name	SM-INTERBUS mapping status		
Slot 1	Pr 15.49	Default	0
Slot 2	Pr 16.49	Range	0 to 255
Slot 3	Pr 17.49	Access	RO

If the SM-INTERBUS operating status parameter (Pr **MM.06**) indicates -3, a mapping configuration error has been detected. The reason for the error is indicated by the SM-INTERBUS mapping status parameter, Pr **MM.49**. When an mapping error has been corrected, reset the SM-INTERBUS by setting Pr **MM.32** to ON (1).

Table 10.5 Generic mapping error codes

Error	Mapping status	Description
No error detected	0	No error detected with IN or OUT cyclic data mapping configuration.
Direct data mapping error	2	Non-cyclic data cannot be used when direct data mapping is enabled.
Invalid non-cyclic mode	3	An invalid non-cyclic data mode has been selected in Pr MM.05 .
Invalid mode value	5	The value entered in Pr MM.05 is not supported.
Multiple non-cyclic mapping error	104	A non-cyclic data mode has been mapped more than once in the IN data mapping configuration parameters. (Pr MM.10 to Pr MM.19)
Configuration read error	110	An error has occurred reading the IN cyclic data mapping configuration parameters (Pr MM.10 to Pr MM.19) from the Unidrive SP.
Invalid source parameter	111	One or more parameters specified in the IN cyclic data mapping configuration (Pr MM.10 to Pr MM.19) is outside of the allowed range for INTERBUS. The allowable parameter range is from Pr 0.00 to Pr 199.99 .
Read mismatch	112	One or more parameters specified in the IN cyclic data mapping configuration (Pr MM.10 to Pr MM.19) cannot be used as a source parameter for IN data. The parameter may not exist, or is a write-only parameter.
Hole in IN data mapping configuration	113	IN cyclic data mapping parameters (Pr MM.10 to Pr MM.19) are not contiguous. It is not possible have an un-used parameter in the middle of the cyclic data.
Inter-option communications error	115	A request to set up an inter-option communications block failed. Either the server does not support block transfer or parameters were not legal.
Too many IN data objects mapped	120	After expanding ranges of block mappings, too many IN cyclic data channels configured.
Mapping over length	121	Total size of all IN cyclic data mappings has exceeded the total size of the cyclic data.
Register mode objects exceeded	122	More than 10 cyclic IN data channels have been selected with direct data mapping mode.
Multiple non-cyclic mapping error	204	A non-cyclic data mode has been mapped more than once in the OUT cyclic data mapping configuration parameters. (Pr MM.20 to Pr MM.29)
Configuration read error	210	An error has occurred reading the OUT cyclic data mapping configuration parameters (Pr MM.20 to Pr MM.29) from the Unidrive SP.

Table 10.5 Generic mapping error codes

Error	Mapping status	Description
Invalid destination parameter	211	One or more parameters specified in the OUT cyclic data mapping configuration (Pr MM.20 to Pr MM.29) is outside of the allowed range for INTERBUS. The allowable parameter range is from Pr 0.00 to Pr 199.99 .
Write mismatch	212	One or more parameters specified in the OUT cyclic data mapping configuration (Pr MM.20 to Pr MM.29) cannot be used as a destination parameter for OUT data. The parameter may not exist, or is a read-only parameter. This error will also occur if an attempt is made to map OUT data to the configuration parameters of a fieldbus option in another slot, unless that fieldbus is configured in register mode, i.e. Pr MM.09 = ON (1).
Hole in OUT data mapping configuration	213	OUT data mapping parameters (Pr MM.20 to Pr MM.29) are not contiguous. It is not possible have an un-used parameter in the middle of the cyclic data.
Duplicate mapping error	214	Two or more OUT cyclic data mapping configuration parameters (Pr MM.20 to Pr MM.29) have been configured with the same destination parameter reference.
Inter-option communications error	215	A request to set up an inter-option communications block failed. Either the server does not support block transfer or parameters were not legal.
Too many OUT data objects mapped	220	After expanding ranges of block mappings, too many OUT cyclic data channels configured.
Mapping over length	221	Total size of all OUT cyclic data mappings has exceeded the total size of the cyclic data.
Register mode objects exceeded	222	More than 10 cyclic OUT data channels have been selected with direct data mapping mode.

10.8 Unidrive SP trip display codes

If the SM-INTERBUS detects an error during operation, it will force a trip on the Unidrive SP. However, the trip code displayed on the Unidrive SP will only indicate which slot initiated the trip. The exact reason for the trip will be indicated in the SM-INTERBUS error code parameter, Pr **MM.50**.

Table 10.6 below shows the possible trip codes that will be displayed on the Unidrive SP when a problem is detected with the SM-INTERBUS, or when the SM-INTERBUS initiates a trip.

Table 10.6 Unidrive SP trip display codes

Slot where trip was initiated			Fault	Description
Slot 1	Slot 2	Slot 3		
SL1.HF	SL2.HF	SL3.HF	Hardware fault	Unidrive SP has detected that a solutions module is present, but is unable to communicate with it. This trip will also occur if the SM-INTERBUS is removed from the Unidrive SP while it is powered up.
SL1.tO	SL2.tO	SL3.tO	Watchdog timeout	Not used by SM-INTERBUS.

Table 10.6 Unidrive SP trip display codes

Slot where trip was initiated			Fault	Description
Slot 1	Slot 2	Slot 3		
SL1.Er	SL2.Er	SL3.Er	Error	User trip generated by the SM-INTERBUS
SL1.nF	SL2.nF	SL3.nF	Not fitted	This trip will occur if a Unidrive SP slot is configured for a SM-INTERBUS, but a different module is fitted in the slot. It will also occur if the SM-INTERBUS has crashed.
SL1.dF	SL2.dF	SL3.dF	Different module fitted	The slot configuration parameters stored in the Unidrive SP are not valid SM-INTERBUS configuration parameters. This trip will also occur when an SM-INTERBUS is fitted to a previously unused slot.

NOTE If Unidrive SP has V1.00.xx firmware fitted, the SLx.nF trip will be seen if the SM-INTERBUS is removed while the Unidrive SP is powered up.

10.9 SM-INTERBUS error codes

Name	SM-INTERBUS error code		
Slot 1	Pr15.50	Default	N/A
Slot 2	Pr16.50	Range	0 to 255
Slot 3	Pr17.50	Access	RO

If the SM-INTERBUS detects an error during operation, it will force a trip the Unidrive SP, and update the SM-INTERBUS error code parameter. The table below shows the SM-INTERBUS error codes.

Table 10.7 SM-INTERBUS error codes

Error Code	Fault	Description
0	No error detected	Indicates that the trip was not caused by the SM-INTERBUS. It is possible to trip the Unidrive SP externally via various communication channels
52	User control word trip	The TRIP bit has been set in the Unidrive or Commander SE control word
61	Configuration error	An invalid configuration has been detected. Refer to PrMM.49 for configuration error codes
65	Network loss	No new messages have been received for the specified network loss trip time.
70	FLASH transfer error	The SM-INTERBUS was unable to upload the configuration parameters from its FLASH memory to the Unidrive SP
74	SM-INTERBUS overtemperature	If the temperature inside the SM-INTERBUS exceeds 82°C, the SM-INTERBUS will trip the Unidrive SP
80	Inter-option communication error	Communications time-out has occurred, but SM-INTERBUS is unable to determine the reason for the error.

Table 10.7 SM-INTERBUS error codes

Error Code	Fault	Description
81	Communication error to slot 1	Direct communications between the SM-INTERBUS and an SM-Applications in another slot has timed out. This can occur when the SM-INTERBUS been mapped to directly read of write _P, _Q, _T or _U registers in an SM-Applications and the SM-Applications has been reset.
82	Communication error to slot 2	
83	Communication error to slot 3	
98	Internal watchdog error	Internal error. Cycle power to the Unidrive SP to reset from this trip. If trip persists, replace the SM-INTERBUS.
99	Internal software error	

10.10 SM-INTERBUS serial number

Name	SM-INTERBUS serial number		
Slot 1	Pr 15.35	Default	N/A
Slot 2	Pr 16.35	Range	32-bit
Slot 3	Pr 17.35	Access	RO

The serial number is a loaded into the SM-INTERBUS during manufacture, and cannot be changed. It contains the last 6 digits of the 10-digit serial number of the label.

11 Advanced Features

11.1 SM-INTERBUS network loss trip

Name	SM-INTERBUS network loss trip timeout		
Slot 1	Pr 15.07	Default	200
Slot 2	Pr 16.07	Range	0 to 3000
Slot 3	Pr 17.07	Access	RW

The SM-INTERBUS resets an internal timer when a valid message is received from the INTERBUS network. The network loss trip is triggered when no new messages are received before the timer times out. When the SM-INTERBUS forces the trip, the trip display on the Unidrive SP will be "SLx.Er", where "x" is the slot number where the trip originated. The SM-INTERBUS error code parameter (Pr MM.50) will show 65 when a network loss trip has occurred.

The network loss trip is not enabled internally until cyclic data has been detected. This prevents spurious network loss trips while the INTERBUS master controller is initialising the INTERBUS network.

Figure 11-1 SM-INTERBUS network loss trip

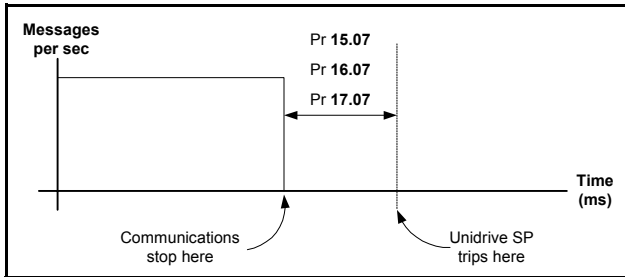

As the trip delay time is reduced, the network loss trip will occur more quickly in the event of a loss of network. However, if the network loss trip time is reduced too far, spurious network loss trips may occur due to time-out occurring before the next message has chance to arrive.

The minimum network loss trip time that can be set depends entirely on the number of messages per second being received under normal operation. As a rough guide, the network loss trip time should be set such that a minimum of 4 messages will be received in the specified time period under normal operating conditions.



The network loss trip can be disabled by setting Pr 15.07, Pr 16.07 or Pr 17.07 to 0. In this case, the Unidrive SP will continue to operate using the last received values. It is the user's responsibility to ensure that adequate safety precautions are taken to prevent damage or injury by disabling the Unidrive SP in the event of a loss of communications.

11.2 Menu 60 - Local Solutions Module parameter access

The menu used to configure the SM-INTERBUS depends on the slot in the Unidrive SP where the SM-INTERBUS is fitted. Menu 60 can be used to ensure that the INTERBUS configuration parameters can be accessed without necessarily knowing in which Unidrive SP slot the SM-INTERBUS is fitted.

When a Menu 60 parameter is accessed from INTERBUS, the SM-INTERBUS will re-direct it to the menu in the Unidrive SP that is associated with the slot where the SM-INTERBUS is fitted.

Table 11.1 Local slot configuration parameter access

Parameter	SM-INTERBUS in slot 1	SM-INTERBUS in slot 2	SM-INTERBUS in slot 3
Pr 60.01 - Pr 60.51	Pr 15.01 - Pr 15.51	Pr 16.01 - Pr 16.51	Pr 17.01 - Pr 17.51

Menu 60 parameters are only accessible from the INTERBUS network using non-cyclic data access methods.

11.3 Mapping To SM-Applications parameters

The SM-INTERBUS reads and writes data directly to and from internal registers in an SM-Applications. 6 sets of 32-bit registers are accessible in the SM-Applications, and block mapping to these registers is supported. Each register in the SM-Applications can be accessed as a virtual parameter.

The SM-INTERBUS can be configured to read data from and write data to an SM-Applications fitted in any slot in the Unidrive SP, simply by specifying the target parameter as shown in Table 11.2.

Table 11.2 SM-Applications internal parameters

SM-Applications parameters	Parameter reference	Direct to slot 1	Direct to slot 2	Direct to slot 3
_Pxx% PLC Registers	Pr 70.xx	Pr 100.xx	Pr 130.xx	Pr 160.xx
_Qxx% PLC Registers	Pr 71.xx	Pr 101.xx	Pr 131.xx	Pr 161.xx
_Rxx% PLC Registers	Pr 72.xx	Pr 102.xx	Pr 132.xx	Pr 162.xx
_Sxx% PLC Registers	Pr 73.xx	Pr 103.xx	Pr 133.xx	Pr 163.xx
_Txx% PLC Registers	Pr 74.xx	Pr 104.xx	Pr 134.xx	Pr 164.xx
_Uxx% PLC Registers	Pr 75.xx	Pr 105.xx	Pr 135.xx	Pr 165.xx
Local Configuration Parameters	Pr 81.xx	Pr 111.xx	Pr 141.xx	Pr 171.xx
Timer Function Parameters	Pr 85.xx	Pr 115.xx	Pr 145.xx	Pr 175.xx
Digital I/O Parameters	Pr 86.xx	Pr 116.xx	Pr 146.xx	Pr 176.xx
Status Parameters	Pr 88.xx	Pr 118.xx	Pr 148.xx	Pr 178.xx
General Parameters	Pr 90.xx	Pr 120.xx	Pr 150.xx	Pr 180.xx
Fast Access Parameters	Pr 91.xx	Pr 121.xx	Pr 151.xx	Pr 181.xx

If the SM-INTERBUS is configured to map data to Pr 70.xx to Pr 91.xx parameters, data will be exchanged with the SM-Applications fitted in the lowest slot number. This method is convenient to use if there is only one SM-Applications fitted to the Unidrive SP, as it guarantees that data will always be written to the SM-Applications, even if it is moved to a different slot. If two SM-Applications are fitted, it is best to map directly to the required slot.

11.3.1 Single SM-Applications fitted

Consider a Unidrive SP with the following configuration:

- Slot 1 - Vacant
- Slot 2 - SM-Applications.
- Slot 3 - SM-INTERBUS.

If a parameter read request comes over INTERBUS to read Pr **71.08**, this will be re-directed to the SM-Applications in the lowest slot number, i.e. the SM-Applications in slot 2. The value in `_Q08%` from slot 2 will be returned.

If a parameter read request comes over INTERBUS to read Pr **131.08**, this will be sent straight to the SM-Applications in slot 2. The value in `_Q08%` from slot 2 will be returned.

If a parameter read request comes over INTERBUS to read Pr **101.08**, this will be sent straight to the SM-Applications in slot 1. As there is no SM-Applications fitted in slot 1, an error message will be returned, indicating that the parameter does not exist.

NOTE If a single SM-Applications is fitted to the Unidrive SP, normal SM-Applications parameter references can be used without problem, as the SM-INTERBUS will automatically divert them to the SM-Applications.

11.3.2 Dual SM-Applications fitted

Consider a Unidrive SP with the following configuration:

- Slot 1 - SM-Applications.
- Slot 2 - SM-Applications.
- Slot 3 - SM-INTERBUS.

If a parameter read request comes over INTERBUS to read Pr **71.08**, this will be re-directed to the SM-Applications in the lowest slot number, i.e. the SM-Applications in slot 1. The value in `_Q08%` from slot 1 will be returned.

If a parameter read request comes over INTERBUS to read Pr **131.08**, this will be sent straight to the SM-Applications in slot 2. The value in `_Q08%` from slot 2 will be returned.

If a parameter read request comes over INTERBUS to read Pr **101.08**, this will be sent straight to the SM-Applications in slot 1. The value in `_Q08%` from slot 1 will be returned.

NOTE If dual SM-Applications are fitted to the Unidrive SP, it is best to access SM-Applications parameters using the direct slot parameter references. If normal SM-Applications parameter references are used, and the SM-Applications is removed from slot 1, these parameter references will be re-directed to slot 2 instead.

11.4 Block mapping

The Unidrive SP provides 10 mapping parameters each for IN data and OUT data. However, some Unidrive SP Solutions Modules are capable of more than 10 words of IN and OUT data, so “block mapping” is provided to allow these additional words to be mapped.

NOTE The SM-INTERBUS is limited to 10 cyclic words, but block mapping can still be used if required.

Block mapping can be used when mapping data to Unidrive SP user parameters in Pr **18.PP**, Pr **19.PP** and Pr **20.PP**, and to the PLC registers in an SM-Applications. If successive mapping parameters are mapped to different higher parameters within the same Unidrive SP user menu or SM-Applications PLC register menu, the mappings will be interpreted as indicating a range of parameters.

If it is required to map to individual parameters within the same menu, ensure that the target registers are listed in descending order. Refer to section 11.4.3 *Avoiding block mapping* on page 56.

11.4.1 IN data

“IN” refers to data as seen by the INTERBUS master controller. Hence, IN data is data that is being transmitted from the Unidrive SP to the INTERBUS master controller.

Consider a Unidrive SP with the following configuration:

- Slot 1 - SM-Applications.
- Slot 2 - SM-Applications.
- Slot 3 - SM-INTERBUS, configured for data format = 10.

To map the five IN 32-bit parameters from registers `_P11%` through to `_P15%`, the following mapping values can be set.

Table 11.3 IN data block mapping example

Mapping parameter	Mapping value	Description
Pr 17.10	7011	Block mapping to registers <code>_P11%</code> to <code>_P15%</code> in the SM-Applications in the lowest slot, i.e. in slot 1.
Pr 17.11	7015	
Pr 17.12 to Pr 17.19	0	Not mapped

Table 11.4 IN data block mapping data structure example

Data word	Target parameter		Data word	Target parameter
IN word 0, 1	<code>_P11%</code> slot 1		IN word 6, 7	<code>_P14%</code> slot 1
IN word 2, 3	<code>_P12%</code> slot 1		IN word 8, 9	<code>_P15%</code> slot 1
IN word 4, 5	<code>_P13%</code> slot 1			

11.4.2 OUT data

“OUT” refers to cyclic data as seen by the INTERBUS master controller. Hence, OUT data is data that is being transmitted from the INTERBUS master controller to the Unidrive SP. Consider a Unidrive SP with the following configuration:

- Slot 1 - SM-Applications.
- Slot 2 - SM-Applications.
- Slot 3 - SM-INTERBUS, configured for data format = 10.

To map the five IN 32-bit parameters from registers `_P11%` through to `_P15%`, the following mapping values can be set.

Table 11.5 OUT data block mapping example

Mapping parameter	Mapping value	Description
Pr 17.20	2031	Block mapping to Unidrive SP parameters Pr 20.31 to Pr 20.35
Pr 17.21	2035	
Pr 17.22 to Pr 17.29	0	Not mapped

Table 11.6 OUT data block mapping data structure example

Data word	Target parameter	Data word	Target parameter
OUT word 0, 1	Pr 20.31	OUT word 6, 7	Pr 20.34
OUT word 2, 3	Pr 20.32	OUT word 8, 9	Pr 20.35
OUT word 4, 5	Pr 20.33		

11.4.3 Avoiding block mapping

In the above sections, block mappings were used to configure 5 channels of IN data to read data from `_P11%` through to `_P15%`, and 5 channels of OUT data to write data to Pr 20.31 through to Pr 20.35. But what happens if the requirement is to map 2 IN channels to `_P11%` and `_P15%` only, and write 2 OUT channels to Pr 20.31 and Pr 20.35 only??

The answer is to simply specify the target parameters in descending order. This means that SM-INTERBUS will not recognise a range of parameters, and 2 channels only will be mapped.

Table 11.7 Non-block data mapping example

Mapping parameter	Mapping value	Description
Pr 17.10	7015	Map to <code>_P15%</code> in the SM-Applications in the lowest slot, i.e. slot 1.
Pr 17.11	7011	Map to <code>_P11%</code> in the SM-Applications in the lowest slot, i.e. slot 1.
Pr 17.12 to Pr 17.19	0	Not mapped
Pr 17.20	2035	Map to Pr 20.35 in the SM-Applications in the lowest slot, i.e. slot 1.
Pr 17.21	2031	Map to Pr 20.31 in the SM-Applications in the lowest slot, i.e. slot 1.
Pr 17.22 to Pr 17.29	0	Not mapped

Table 11.8 Non-block data structure example

Data word	Target parameter	Data word	Target parameter
IN word 0, 1	<code>_P15%</code> slot 1	OUT word 0, 1	Pr 20.35
IN word 2, 3	<code>_P11%</code> slot 1	OUT word 2, 3	Pr 20.31
IN word 4-9	Not mapped	OUT word 4-9	Not mapped

11.5 Direct data mapping

Name	Direct data mapping enable		
Slot 1	Pr 15.09	Default	OFF (0)
Slot 2	Pr 16.09	Range	OFF (0) or ON (1)
Slot 3	Pr 17.09	Access	RW

By default, Pr **MM.10** to Pr **MM.29** are used as pointers to specify the destination parameter for OUT data received from the master controller, and the source parameter of IN data to be transmitted to the master controller.

When direct data mapping is enabled, Pr **MM.10** to Pr **MM.29** are used as the actual destination and source parameters for OUT data and IN data respectively. Hence, OUT data values arriving from the PLC will be written directly into Pr **MM.20** to Pr **MM.29**.

NOTE Non-cyclic data cannot be used when direct data mapping mode is enabled.

When direct data mapping mode is enabled, all mapping parameters (Pr **MM.10** to Pr **MM.29**) will be reset to 0. When data compression is OFF, the number of data words specified in Pr **MM.05** must be an even number. If an odd number is specified, the appropriate parameter will be set to specify the next lowest even number of data words, i.e. a value of 7 in Pr **MM.05** will only handle 6 data words or 3 data channels.

Table 11.9 Direct data mapping configurations (data compression OFF)

Pr MM.05	Description
2 to 10	The first 10 IN channels will be written directly to Pr MM.10 to Pr MM.19 , and the first 10 OUT channels will be read directly from Pr MM.20 to Pr MM.29 .
100 to 109 200 to 206 300 to 309	Non-cyclic data cannot be used in direct data mapping mode. The SM-INTERBUS operating status parameter (Pr MM.49) will indicate -3, and mapping error code (Pr MM.50) will indicate 2.

Parameters Pr **MM.10** to Pr **MM.29** are all 16-bit parameters, each data channel will be reduced to 16-bits when Data compression is enabled. Hence, a maximum of 10 data can be specified in Pr **MM.05**, or Pr **MM.39** and Pr **MM.40**.

Table 11.10 Direct data mapping configurations (data compression ON)

Pr MM.05	Description
1 to 10	The first 10 OUT channels will be written directly to Pr MM.10 to Pr MM.19 , and the first 10 IN channels will be read directly from Pr MM.20 to Pr MM.29 .
100 to 109 200 to 206 300 to 309	Non-cyclic data cannot be used in direct data mapping mode. The SM-INTERBUS operating status parameter (Pr MM.49) will indicate -3, and mapping error code (Pr MM.50) will indicate 2.

11.6 Cyclic data compression

Name	Cyclic data compression enable		
Slot 1	Pr 15.34	Default	OFF (0)
Slot 2	Pr 16.34	Range	OFF (0) or ON (1)
Slot 3	Pr 17.34	Access	RW

By default, the SM-INTERBUS uses 32-bits, i.e. 2 data words, for each data channel, even if the target parameter in the Unidrive SP is a 16-bit parameter. This strategy ensures that the cyclic data transmitted over the INTERBUS network is kept aligned with memory locations in new 32-bit PLCs.

Table 11.11 shows an example set of mapping parameters where 5 IN and 5 OUT cyclic data channels are required. With data compression disabled, each data channel uses 32-bits, i.e. 2 data words, so a total of 10 words are required, i.e. Pr **MM.05** = 10.

Table 11.11 Example cyclic data channel mapping

Data channel	Data words used	Mapping for slot 3	Setting	Data width	Mapping status
IN channel 0	IN word 0, 1	Pr 17.10	1040	16-bit	Pr 10.40 , status word
IN channel 1	IN word 2, 3	Pr 17.11	201	32-bit	Pr 2.01 , post-ramp speed ref
IN channel 2	IN word 4, 5	Pr 17.12	420	16-bit	Pr 4.20 , motor load as % of rated motor load
IN channel 3	IN word 6, 7	Pr 17.13	1421	16-bit	Pr 14.21 , PID feedback
IN channel 4	IN word 8, 9	Pr 17.14	1401	16-bit	Pr 14.01 , PID output
OUT channel 0	OUT word 0, 1	Pr 17.20	642	16-bit	Pr 6.42 , control word
OUT channel 1	OUT word 2, 3	Pr 17.21	121	32-bit	Pr 1.21 , digital speed ref 1
OUT channel 2	OUT word 4, 5	Pr 17.22	211	32-bit	Pr 2.11 , acceleration ramp
OUT channel 3	OUT word 6, 7	Pr 17.23	221	32-bit	Pr 2.21 , deceleration ramp
OUT channel 4	OUT word 8, 9	Pr 17.24	1420	16-bit	Pr 14.20 , PID reference

When data compression is enabled by setting Pr **MM.34** = ON, a data channel will only use 32 bits if the target Unidrive SP parameter is a 32 bit parameter. If the target Unidrive SP parameter for a data channel is only 1, 8 or 16 bits wide, only 16 bits will be used for that particular data channel. Hence, the IN data will only use a total of 6 words, and the OUT data will only use a total of 8 words. Pr **MM.05** can now be set to 8.

It is also advisable to keep 16-bit parameters paired together. This prevents mis-alignment of cyclic data with 32-bit PLC registers when using auto-mapping facilities to configure the INTERBUS network. By swapping the mappings for IN channel 1 with IN channel 2, and moving OUT channel 4 to OUT channel 1, the data channel structure will appear as shown in Table 11.12.

Table 11.12 compressed cyclic data channel mapping

Data channel	Data words used	Mapping for slot 3	Setting	Data width	Mapping status
IN channel 0	IN word 0	Pr 17.10	1040	16-bit	Pr 10.40 , status word
IN channel 1	IN word 1	Pr 17.11	420	16-bit	Pr 4.20 , motor load as % of rated motor load
IN channel 2	IN word 2, 3	Pr 17.12	201	32-bit	Pr 2.01 , post-ramp speed ref
IN channel 3	IN word 4	Pr 17.13	1421	16-bit	Pr 14.21 , PID feedback
IN channel 4	IN word 5	Pr 17.14	1401	16-bit	Pr 14.01 , PID output
OUT channel 0	OUT word 0	Pr 17.20	642	16-bit	Pr 6.42 , control word
OUT channel 1	OUT word 1	Pr 17.21	1420	16-bit	Pr 14.20 , PID reference
OUT channel 2	OUT word 2, 3	Pr 17.22	121	32-bit	Pr 1.21 , digital speed ref 1
OUT channel 3	OUT word 4, 5	Pr 17.23	211	32-bit	Pr 2.11 , acceleration ramp
OUT channel 4	OUT word 6, 7	Pr 17.24	221	32-bit	Pr 2.21 , deceleration ramp

11.6.1 Unidrive SP 32-bit parameters

The table below lists the 32-bit parameters in the Unidrive SP that can be set as target parameters for cyclic data.

Table 11.13 Unidrive SP 32-bit parameters

Menu	32-bit parameters							
Menu 1	Pr 1.01	Pr 1.02	Pr 1.03	Pr 1.04	Pr 1.06	Pr 1.07	Pr 1.17	Pr 1.18
	Pr 1.21	Pr 1.22	Pr 1.23	Pr 1.24	Pr 1.25	Pr 1.26	Pr 1.27	Pr 1.28
	Pr 1.36	Pr 1.37	Pr 1.39					
Menu 2	Pr 2.01	Pr 2.07	Pr 2.11	Pr 2.12	Pr 2.13	Pr 2.14	Pr 2.15	Pr 2.16
	Pr 2.17	Pr 2.18	Pr 2.19	Pr 2.21	Pr 2.22	Pr 2.23	Pr 2.24	Pr 2.25
	Pr 2.26	Pr 2.27	Pr 2.28	Pr 2.29				
Menu 3	Pr 3.01	Pr 3.02	Pr 3.03	Pr 3.10	Pr 3.18	Pr 3.22	Pr 3.27	
Menu 4	Pr 4.01	Pr 4.02	Pr 4.08	Pr 4.17				
Menu 5	Pr 5.01	Pr 5.03	Pr 5.04	Pr 5.07	Pr 5.08	Pr 5.24	Pr 5.25	
Menu 7	Pr 7.51							
Menu 11	Pr 11.32							
Menu 15	Pr 15.03	Pr 15.19	Pr 15.35					
Menu 16	Pr 16.03	Pr 16.19	Pr 16.35					
Menu 17	Pr 17.03	Pr 17.19	Pr 17.35					
Menu 20	Pr 20.21	Pr 20.22	Pr 20.23	Pr 20.24	Pr 20.25	Pr 20.26	Pr 20.27	Pr 20.28
	Pr 20.29	Pr 20.30	Pr 20.31	Pr 20.32	Pr 20.33	Pr 20.34	Pr 20.35	Pr 20.36
	Pr 20.37	Pr 20.38	Pr 20.39	Pr 20.40				
Menu 21	Pr 21.01	Pr 21.02	Pr 21.04	Pr 21.05	Pr 21.07	Pr 21.08	Pr 21.14	Pr 21.24
Menu 70 to Menu 75	Pr 70.00 to Pr 70.99			Pr 71.00 to Pr 71.99			Pr 72.00 to Pr 72.99	
	Pr 73.00 to Pr 73.99			Pr 74.00 to Pr 74.99			Pr 75.00 to Pr 75.99	
Menu 100 to Menu 105	Pr 100.00 to Pr 100.99			Pr 101.00 to Pr 101.99			Pr 102.00 to Pr 102.99	
	Pr 103.00 to Pr 103.99			Pr 104.00 to Pr 104.99			Pr 105.00 to Pr 105.99	
Menu 130 to Menu 135	Pr 130.00 to Pr 130.99			Pr 131.00 to Pr 131.99			Pr 132.00 to Pr 132.99	
	Pr 133.00 to Pr 133.99			Pr 134.00 to Pr 134.99			Pr 135.00 to Pr 135.99	
Menu 160 to Menu 165	Pr 160.00 to Pr 160.99			Pr 161.00 to Pr 161.99			Pr 162.00 to Pr 162.99	
	Pr 163.00 to Pr 163.99			Pr 164.00 to Pr 164.99			Pr 165.00 to Pr 165.99	

Parameters in menus 15, 16 and 17 are only 32-bit if one of the intelligent encoders is fitted in the appropriate Unidrive SP slot. Menu 70 to menu 165 parameters are only available if an SM-Applications module is fitted in the appropriate slot.

11.7 EVENT task trigger in SM-Applications

Name	SM-Applications EVENT task trigger		
Slot 1	Pr 61.41	Default	0
Slot 2	Pr 61.42	Range	0 to 4
Slot 3	Pr 61.43	Access	WO

The SM-Applications has 4 EVENT tasks available for use in the DPL Program, and the SM-INTERBUS can be configured to trigger one of these tasks.

An EVENT task is triggered when the trigger parameter is actually written to, while the value written (1 to 4) determines which task is actually triggered. The task trigger parameter can be written to using cyclic or non-cyclic data.

Table 11.14 EVENT task trigger parameters

Trigger parameter	Value written to trigger parameter				
	0	1	2	3	4
Pr 61.40*	No action	EVENT*	EVENT1*	EVENT2*	EVENT3*
Pr 61.41	No action	EVENT task in slot 1	EVENT1 task in slot 1	EVENT2 task in slot 1	EVENT3 task in slot 1
Pr 61.42	No action	EVENT task in slot 2	EVENT1 task in slot 2	EVENT2 task in slot 2	EVENT3 task in slot 2
Pr 61.43	No action	EVENT task in slot 3	EVENT1 task in slot 3	EVENT2 task in slot 3	EVENT3 task in slot 3

* - the specified EVENT task will be triggered in the SM-Applications fitted in the lowest slot number on the Unidrive SP.

When an EVENT task runs in the SM-Applications, the reason Code parameter (Pr 90.12 to Pr 90.15 for EVENT to EVENT3 task respectively) will indicate why the event task was triggered. The reason codes for Solution Modules are shown in Chapter 11.15 *EVENT task reason codes* on page 60. (Refer to the *SM-Applications User Guide* for full details.)

Table 11.15 EVENT task reason codes

Solution Module	Reason code
SM-DeviceNet	1
SM-PROFIBUS-DP	2
SM-CANopen	3
SM-INTERBUS	4
SM-CAN	5

NOTE

If cyclic data is used to trigger an EVENT task in an SM-Applications, it is best to map the last OUT cyclic data word to the EVENT task trigger parameter. As cyclic data is written to destination parameters in the order in which it is received, this guarantees that all received cyclic data will have been written to the target parameters BEFORE the EVENT task runs in the SM-Applications.

11.8 Unidrive compatible control word

Name	Unidrive compatible control word		
Slot 1	Pr 61.11	Default	0
Slot 2	Pr 61.11	Range	0 to 65535
Slot 3	Pr 61.11	Access	RW

This feature converts the Unidrive fieldbus control word to allow it to be used on the SM-INTERBUS to the control the Unidrive SP. The existing control strategy MUST have been designed for a Unidrive operating in wire-proof PLC mode, i.e. Pr 6.04 = 4. The Unidrive compatible control word can be accessed by mapping a cyclic data channel to Pr 61.11. Reading Pr 61.12 will return the Unidrive SP status word (Pr 10.40).

b15	b14	b13	b12b	b11	b10	b9	b8
M6	M5	Pr 18.33	M3	M2	M1	M0	Pr 18.32

b7	b6	b5	b4	b3	b2	b1	b0
Pr 18.31	Pr 1.46	Pr 1.45	TRIP	RUN REV	JOG	RUN FWD	ENABLE

NOTE For safety reasons, the external HARDWARE ENABLE signal (terminal 31) must be present before the fieldbus control word can be used to start the Unidrive SP. Typically, this terminal is controlled by the external emergency stop circuit to ensure that the Unidrive SP is disabled in an emergency situation.

The ENABLE, RUN FWD, JOG and RUN REV bits are transferred directly to the Unidrive SP control word, Pr 6.42. The NOT STOP bit is also set to 1. If a MASK bit (shown as "Mx") is set to 1, this will set Pr 6.43 to 1 in the Unidrive SP. This enables the Unidrive SP control word (Pr 6.42). Clearing all MASK bits to 0 will reset Pr 6.43 to 0, and the Unidrive SP will revert to terminal control.

NOTE MASK bit operation is different to Unidrive, but an existing control strategy will produce the same result.

The TRIP bit (b4) will cause an "SLx.Er" trip with error code 52 when set to 1. Pr 18.31 to Pr 18.33 are general user parameters and do not have mask bits.

Table 11.16 Unidrive compatible control word

Bit	Function	Description
0	ENABLE	Set to 1 to put the Unidrive SP in READY mode. (The hardware ENABLE must also be present.) The RUN FWD, JOG and RUN REV bits will have no effect unless the ENABLE bit is set to 1. The Unidrive outputs are disabled immediately when the ENABLE bit is reset to 0, and the motor will coast to stop
1	RUN FWD	Set to 1 to run the motor in the forwards direction. Reset to 0 to decelerate the motor to a controlled stop before the Unidrive SP output stage is disabled
2	JOG	Set to 1 with RUN FWD or RUN REV bit also set to jog the motor in the appropriate direction. The Unidrive SP will ramp the motor to the normal speed or stop when the JOG bit is reset to 0, depending on the status of the RUN FWD and RUN REV bits.
3	RUN REV	Set to 1 to run the motor in the reverse direction. When reset to 0, the Unidrive SP will decelerate the motor to stop before the outputs are disabled
4	TRIP	Set to 1 to trip the Unidrive SP on "SLx.Er" with error code 52.

Table 11.16 Unidrive compatible control word

Bit	Function	Description
5	Pr 1.45	Preset Reference Select. These bits are used to select the digital speed references used. Refer to the Unidrive SP <i>User Guide</i> for more information.
6	Pr 1.46	
7	Pr 18.31	User application bit
8	Pr 18.32	User application bit
9	M0	ENABLE mask bit
10	M1	RUN FWD mask bit
11	M2	JOG mask bit
12	M3	RUN REV mask bit
13	Pr 18.33	User application bit
14	M5	Mask bits for the preset reference select bits
15	M6	

Some example control words for wire-proof PLC mode are given in the table below.

Table 11.17 Unidrive compatible control word examples

b15-b12	b11-b8	b7-b4	b3-b0	Value	Action
0000	0010	0000	0000	0x0200	Drive disable
0001	1110	0000	0001	0x1E01	Enabled + stopped
0001	1110	0000	0011	0x1E03	Enabled + run fwd
0001	1110	0000	1001	0x1E09	Enabled + run rev
0001	1110	0000	1101	0x1E0C	Enabled + jog rev

11.9 Commander SE compatible control word

Name	Commander SE compatible control word		
Slot 1	Pr 61.12	Default	0
Slot 2	Pr 61.12	Range	0 to 65535
Slot 3	Pr 61.12	Access	RW

This feature converts the Commander SE fieldbus control word to allow it to be used on the SM-INTERBUS to control the Unidrive SP. The Commander SE compatible control word can be accessed by mapping a cyclic data channel to Pr 61.12. Reading Pr 61.12 will return the Unidrive SP status word (Pr 10.40).

b15	b14	b13	b12b	b11	b10	b9	b8
Reserved							
b7	b6	b5	b4	b3	b2	b1	b0
TRIP	RESET	DIG REF	FBUS CTRL	RUN REV	JOG	RUN FWD	ENABLE

NOTE For safety reasons, the external HARDWARE ENABLE signal (terminal 31) must be present before the fieldbus control word can be used to start the Unidrive SP. Typically, this terminal is controlled by the external Emergency Stop circuit to ensure that the Unidrive SP is disabled in an emergency situation.

To enable fieldbus control of the Unidrive SP, set the FBUS CTRL bit to 1. The 0-1 transition of the FBUS CTRL bit will cause the SM-INTERBUS to set Pr **6.43** to 1 in the Unidrive SP, and enable the Unidrive SP control word. When the FBUS CTRL bit is reset to 0, the SM-INTERBUS will reset Pr **6.43** to 0, thus putting the Unidrive SP back into terminal control mode.

The DIG REF bit allows the source of the speed reference to be changed. The 0-1 transition of the DIG REF will cause the SM-INTERBUS to set Pr **1.14** to 3, selecting digital speed reference as the source of the speed reference. (By default, this will be digital speed reference 1, Pr **1.21**.) When the DIG REF bit is reset to 0, the SM-INTERBUS will set Pr **1.14** to 1, selecting the analog input as the source of the speed reference. (The actual digital speed reference selected will depend on the setting of the digital speed reference selector, Pr **1.15**)

Table 11.18 Commander SE compatible control word

Bit	Function	Description
0	ENABLE	Must be set to 1 to put the Unidrive SP in READY mode. Resetting to 0 will immediately disable the Unidrive SP, and the motor will coast to stop. The external HARDWARE ENABLE signal (terminal 30) must also be present before the Unidrive SP can be enabled and run.
1	RUN FWD	Set to 1 (with ENABLE set to 1) to run the motor in the forward direction. When reset to 0, the Unidrive SP will decelerate the motor to a controlled stop before the outputs disabled
2	JOG	Set to 1 with RUN FWD or RUN REV bit also set to one to jog the motor in the appropriate direction. The Unidrive SP will ramp the motor to the normal speed reference if the bit is reset to 0
3	RUN REV	Set to 1 (with ENABLE set to 1) to run the motor in the reverse direction. When reset to 0, the Unidrive SP will decelerate the motor to a controlled stop before the outputs disabled
4	FBUS CTRL	A 0-1 transition of this bit will set Pr 6.43 to 1 to enable the Unidrive SP control word. A 1-0 transition will reset Pr 6.43 to 0, setting the Unidrive SP back into terminal control.)
5	DIG REF	A 0-1 transition of this bit will set Pr 1.14 to 3 to select digital speed reference control. A 1-0 transition will reset Pr 1.14 to 1 to select analog reference control.
6	RESET	A 0-1 transition will reset the Unidrive SP from a trip condition, provided that the cause of the trip has been removed.
7	TRIP	A 0-1 transition will force an "SLx.Er" trip with Error Code 52 on the Unidrive SP. If the RESET and TRIP bits change from 0 to 1 on the same cycle, the TRIP bit will take priority
8 - 15	Reserved	Reserved

Some example control word values to control the Unidrive SP are given in the table below.

Table 11.19 Commander SE compatible control word examples

Control Word (Hex)	Control Word (Dec)	Action
0x0000	0	Control word disabled, Unidrive SP will operate under terminal control
0x0010	16	Disabled
0x0011	17	Enabled, stopped
0x0033	51	Enabled, run fwd, digital speed ref
0x0039	57	Enabled, run rev, digital speed ref

Table 11.19 Commander SE compatible control word examples

Control Word (Hex)	Control Word (Dec)	Action
0x0013	19	Enabled, run fwd, analog speed ref
0x0019	25	Enabled, run rev, analog speed ref
0x0017	23	Enabled, jog fwd
0x001D	29	Enabled, jog rev
0x0080	128	Trip Commander SE
0x0070	112	Reset Commander SE into fieldbus control
0x0040	64	Reset Commander SE into terminal control

11.10 Restore SM-INTERBUS defaults

Name	Restore SM-INTERBUS defaults		
Slot 1	Pr 15.30	Default	OFF (0)
Slot 2	Pr 16.30	Range	OFF (0) or ON (1)
Slot 3	Pr 17.30	Access	RW

If the SM-INTERBUS detects that the Unidrive SP has been restored to default values, it will over-write the slot configuration parameters with the SM-INTERBUS default values.

NOTE If the stored values in the Unidrive SP are for a different type of Solutions Module, the SM-INTERBUS will trip “SLx.DF”, but no error code will be set. It will over-write the parameter values with the SM-INTERBUS default values, but will NOT store these values in the Unidrive SP.

Pr **MM.30** specifies whether the default values should be written to the SM-INTERBUS FLASH memory. If Pr **MM.30** is set to ON, the default values will be written into the SM-INTERBUS FLASH memory.

The full sequence of events to restore default settings for a SM-INTERBUS fitted in slot 3 is as follows:

1. Set Pr **17.00** to 1233 to restore European defaults (1244 for USA defaults) to the Unidrive SP.
2. INTERBUS communications will be stopped.
3. The Unidrive SP will load and store its default parameter values.
4. Default parameter values for the SM-INTERBUS will be loaded in Pr **17.PP** parameters.
5. If Pr **17.30** is set to ON (1), the SM-INTERBUS default parameter values will be stored in the SM-INTERBUS FLASH memory.
6. The SM-INTERBUS will reset and re-initialise using the default values.

11.11 Restore previous SM-INTERBUS configuration

Name	Upload from SM-INTERBUS FLASH memory		
Slot 1	Pr 15.33	Default	OFF (0)
Slot 2	Pr 16.33	Range	OFF (0) or ON (1)
Slot 3	Pr 17.33	Access	RW

If valid configuration parameters have previously been stored in the SM-INTERBUS FLASH memory, these values can be restored to the Unidrive SP. When the configuration parameter values have been uploaded to the Unidrive SP, the SM-INTERBUS will reset and re-configure using the updated parameter values.

This feature allows a pre-configured SM-INTERBUS to be fitted to a Unidrive SP without losing the SM-INTERBUS configuration.

NOTE If the SM-INTERBUS is unable to upload the configuration parameters to the Unidrive SP, or configuration parameters have never been stored in the SM-INTERBUS FLASH memory, the Unidrive SP will trip “SLx.ER” and set the error code (Pr **MM.49**) to 70.

When Pr **MM.33** is set to ON, the SM-INTERBUS will transfer the configuration parameters from its FLASH memory to the Unidrive SP, over-writing the existing values in the Unidrive SP.

The full sequence of events for restoring values from a SM-INTERBUS fitted in slot 3 is as follows:

1. Set Pr **17.33** to ON.
2. INTERBUS communications will be stopped.
3. The SM-INTERBUS will overwrite all Pr **17.PP** parameters with the values stored in its internal FLASH memory.
4. Pr **17.33** will be reset to OFF.
5. The SM-INTERBUS will reset and re-initialise using the restored values.

This procedure will NOT store the updated Unidrive SP parameters.

NOTE The SM-INTERBUS will restore its configuration parameters to the menu of parameters associated with the slot that it is installed in. If an SM-INTERBUS is moved from slot 3 on a Unidrive SP, it can be re-installed in any slot on another Unidrive SP.

12 Quick Reference

12.1 Complete parameter reference

Table 12.1 shows every parameter available in the Unidrive SP for configuring the SM-INTERBUS, plus a cross-reference to the section in the manual where more information can be found.

Table 12.1 SM-INTERBUS configuration parameter reference

Slot 1	Slot 2	Slot 3	Default	Cross Reference	Description
Pr 15.01	Pr 16.01	Pr 17.01	----	Section 10.1, page 45	Module ID code
Pr 15.02	Pr 16.02	Pr 17.02	----	Section 10.2, page 45	Major firmware version
Pr 15.03	Pr 16.03	Pr 17.03	0	----	Reserved
Pr 15.04	Pr 16.04	Pr 17.04	0	----	Reserved
Pr 15.05	Pr 16.05	Pr 17.05	4	Section 6.2, page 12	Data format
Pr 15.06	Pr 16.06	Pr 17.06	----	Section 10.5, page 46	Operating status
Pr 15.07	Pr 16.07	Pr 17.07	200	Section 11.1, page 52	Network loss trip timeout
Pr 15.08	Pr 16.08	Pr 17.08	OFF (0)	----	Reserved
Pr 15.09	Pr 16.09	Pr 17.09	OFF (0)	Section 11.5, page 57	Direct data mapping enable
Pr 15.10	Pr 16.10	Pr 17.10	1040	Section 6.2, page 12	IN mapping 0
Pr 15.11	Pr 16.11	Pr 17.11	201		IN mapping 1
Pr 15.12	Pr 16.12	Pr 17.12	0		IN mapping 2
Pr 15.13	Pr 16.13	Pr 17.13	0		IN mapping 3
Pr 15.14	Pr 16.14	Pr 17.14	0		IN mapping 4
Pr 15.15	Pr 16.15	Pr 17.15	0		IN mapping 5
Pr 15.16	Pr 16.16	Pr 17.16	0		IN mapping 6
Pr 15.17	Pr 16.17	Pr 17.17	0		IN mapping 7
Pr 15.18	Pr 16.18	Pr 17.18	0		IN mapping 8
Pr 15.19	Pr 16.19	Pr 17.19	0		IN mapping 9
Pr 15.20	Pr 16.20	Pr 17.20	642	Section 6.2, page 12	OUT mapping 0
Pr 15.21	Pr 16.21	Pr 17.21	121		OUT mapping 1
Pr 15.22	Pr 16.22	Pr 17.22	0		OUT mapping 2
Pr 15.23	Pr 16.23	Pr 17.23	0		OUT mapping 3
Pr 15.24	Pr 16.24	Pr 17.24	0		OUT mapping 4
Pr 15.25	Pr 16.25	Pr 17.25	0		OUT mapping 5
Pr 15.26	Pr 16.26	Pr 17.26	0		OUT mapping 6
Pr 15.27	Pr 16.27	Pr 17.27	0		OUT mapping 7
Pr 15.28	Pr 16.28	Pr 17.28	0		OUT mapping 8
Pr 15.29	Pr 16.29	Pr 17.29	0		OUT mapping 9
Pr 15.30	Pr 16.30	Pr 17.30	0	Section 11.10, page 64	Restore SM-INTERBUS defaults

Table 12.1 SM-INTERBUS configuration parameter reference

Slot 1	Slot 2	Slot 3	Default	Cross Reference	Description
Pr 15.31	Pr 16.31	Pr 17.31	0	Section 6.4, page 16	Store to SM-INTERBUS FLASH memory
Pr 15.32	Pr 16.32	Pr 17.32	0	Section 5.6, page 11	Reset SM-INTERBUS
Pr 15.33	Pr 16.33	Pr 17.33	0	Section 11.11, page 64	Restore previous configuration from SM-INTERBUS FLASH memory
Pr 15.34	Pr 16.34	Pr 17.34	0	Section 11.6, page 57	Data compression enable
Pr 15.35	Pr 16.35	Pr 17.35	----	Section 10.10, page 51	Serial number
Pr 15.36	Pr 16.36	Pr 17.36	OFF (0)	----	Reserved
Pr 15.37	Pr 16.37	Pr 17.37	OFF (0)		
Pr 15.38	Pr 16.38	Pr 17.38	0		
Pr 15.39	Pr 16.39	Pr 17.39	0		
Pr 15.40	Pr 16.40	Pr 17.40	0		
Pr 15.41	Pr 16.41	Pr 17.41	0		
Pr 15.42	Pr 16.42	Pr 17.42	0		
Pr 15.43	Pr 16.43	Pr 17.43	0		
Pr 15.44	Pr 16.44	Pr 17.44	0		
Pr 15.45	Pr 16.45	Pr 17.45	0		
Pr 15.46	Pr 16.46	Pr 17.46	0		
Pr 15.47	Pr 16.47	Pr 17.47	0		
Pr 15.48	Pr 16.48	Pr 17.48	0		
Pr 15.49	Pr 16.49	Pr 17.49	----	Section 10.7, page 48	SM-INTERBUS cyclic data mapping status
Pr 15.50	Pr 16.50	Pr 17.50	----	Section 10.9, page 50	SM-INTERBUS error codes
Pr 15.51	Pr 16.51	Pr 17.51	----	Section 10.2, page 45	Minor firmware version

Table 12.2 shows every virtual parameter available in the SM-INTERBUS, plus a cross-reference to the section in this manual where more information can be found.

Table 12.2 SM-INTERBUS virtual parameter reference

Slot 1	Default	Cross Reference	Description
Pr 61.01	----	----	Mapped directly to Pr 1.00 to allow access to Parameter 0
Pr 61.11	----	Section 11.8, page 61	Unidrive compatible control word
Pr 61.12	----	Section 11.9, page 62	Commander SE compatible control word
Pr 61.35	----	Section 10.10, page 51	Serial number

Table 12.2 SM-INTERBUS virtual parameter reference

Slot 1	Default	Cross Reference	Description
Pr 61.40	0	Section 11.7, page 60	SM-Applications event task trigger (lowest slot)
Pr 61.41	0		SM-Applications event task trigger (slot 1)
Pr 61.42	0		SM-Applications event task trigger (slot 2)
Pr 61.43	0		SM-Applications event task trigger (slot 3)
Pr 61.50	0	Section 8.1, page 23	CT Single Word (Mode 1) non-cyclic data mapping parameter
Pr 61.51	0	Section 8.2, page 33	PPO 4 Word (Mode 2) non-cyclic data mapping parameter